

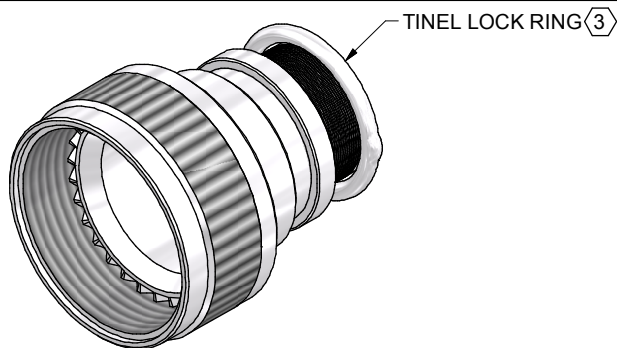

**THE DATASHEET OF
TXR54AB00-1606AI-CS1000**







CODE 54 - TINEL-LOCK BACKSHELL

TXR54AB00-1608AI-S

SERIES _____
 TXR: RING INCLUDED
 (SEE RING OPTION)
 TX: RING NOT INCLUDED
 CONNECTOR INTERFACE _____
 MATERIAL _____
 REFER TO CH00-0250-008
 FINISH _____
 REFER TO CH00-0250-008
 ANGLE _____
 DASH NUMBER (TABLE 1) _____
 ENTRY SIZE (TABLE 2) _____
 RING OPTION _____
 AI - TO SUIT SINGLE BRAID
 BI - TO SUIT DOUBLE BRAID
 FOR TX, LEAVE BLANK
 MODIFICATION CODE _____
 REFER TO CH00-0250-008

NOTES:

1. THIS PRODUCT IS DESIGNED TO TERMINATE A BRAIDED CABLE SHIELD AND A HEAT SHRINKABLE LIPPED BOOT TO A CONNECTOR.
- (2) FOR ADDITIONAL DIMENSIONS, ORDERING INFORMATION AND MODIFICATIONS, SEE CH00-0250-008.
- (3) SEE DRAWING TR FOR DETAIL ON TINEL-LOCK RING, RINGS ARE DESIGNED TO BE HEATED ELECTRICALLY, ALL RINGS ARE MARKED WITH THERMOCHROMIC PAINT WHICH CHANGES COLOUR WHEN INSTALLATION TEMPERATURE IS REACHED.
4. BACKSHELL TO BE PERMANENTLY MARKED/BAGGED AND LABELLED WITH CODE IDENTIFICATION NUMBER AND PART NUMBER LESS RING DESIGNATOR. (e.g. 06090-TXR54AB00-1206). RING SHALL BEAR NO MARKING.
- (5) FOR LARGER ENTRY SIZES, A 2 PIECE BACKSHELL ASSEMBLY (TYPE 2) IS SUPPLIED.
- (6) BACKSHELL MATES TO MIL-C-81703, SERIES III, MS3424, MS3446, MS3464, MS3467, MS3468
- (7) BACKSHELL MATES TO MIL-C-5015G, MS3400 SERIES, CLASS D, E, K, L, U & W, MS3400, MS3401, MS3404, MS3406 MS3424, MS3446, MS3464, MS3467, MS3468, MS3450, MS3451, MS3454, MS3456, MS3470, MS3471, MS3472, MS3474, MS3475, MS3476. MIL-C-83723, SERIES II, CLASS A & L. MIL-C-83723, SERIES I & II, CLASS A, G, K, R & S: M83723/1, /2, /3, /4, /5, /6, /7, /8, /13, /14, /36, /37, /38, /39, /40, /41, /42, /43, /48, /49, /65, /66, /67, /68, /69, /70, /71, /72, /73, /74, /75, /76, /77, /78, /82, /83, /84, /85, /86, /87, /91, /92, /95, /97, /98, (MS3155 CONTROLLED INTERFACE).
- (8) THESE DIMENSIONS APPLY IF A SELF-LOCKING COUPLING NUT IS USED.

DRAWN	K.WINCZURA	DATE	01/12/2014	 3RD ANGLE PROJECTION NOT TO SCALE UNLESS OTHERWISE SPECIFIED ALL DIMENSIONS IN MILLIMETRES GENERAL TOL LINEAR +/-0.25MM ANGULAR +/- 1°	TITLE: TINEL-LOCK BACKSHELL	 Polamco 											
CHECKED		01/12/2014	ASSY USED ON: MIL-DTL-26482 SERIES II / MIL-DTL-83723 SERIES I & III														
APPROVED	K.SHEPPARD	04/12/2014			REVISIONS <table border="1"> <thead> <tr> <th>LTR</th> <th>DESCRIPTION</th> <th>DATE</th> <th>APPROVED</th> </tr> </thead> <tbody> <tr> <td>K</td> <td>REVISED PER ECO-15-002312</td> <td>13.02.15</td> <td>H.SMITH</td> </tr> <tr> <td>L</td> <td>REVISED PER ECO-17-009011</td> <td>21.06.17</td> <td>D.JONES</td> </tr> </tbody> </table>		LTR	DESCRIPTION	DATE	APPROVED	K	REVISED PER ECO-15-002312	13.02.15	H.SMITH	L	REVISED PER ECO-17-009011	21.06.17
LTR	DESCRIPTION	DATE	APPROVED														
K	REVISED PER ECO-15-002312	13.02.15	H.SMITH														
L	REVISED PER ECO-17-009011	21.06.17	D.JONES														
APPROVED																	
TE CAGE CODE: 06090 POLAMCO/TE CAGE CODE: U5792					DRAWING NO: TXR54	DRAWING REV: L	SHT 1										
TE CONNECTIVITY - POLAMCO LTD RESERVES THE RIGHT TO AMEND THIS DRAWING AND THE INFORMATION SET FORTH HEREON AT ANY TIME. USERS SHOULD INDEPENDENTLY EVALUATE THE SUITABILITY OF THE PRODUCT FOR THEIR APPLICATION.																	

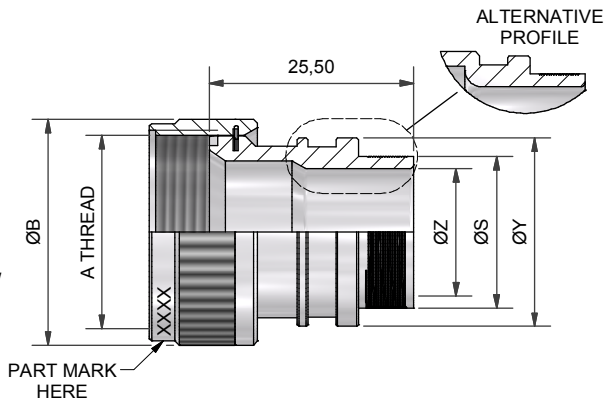

STRAIGHT BACKSHELL - TYPE 1

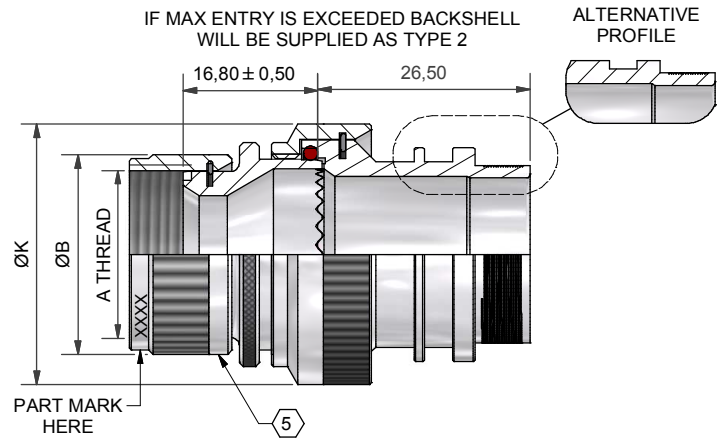

STRAIGHT BACKSHELL - TYPE 2

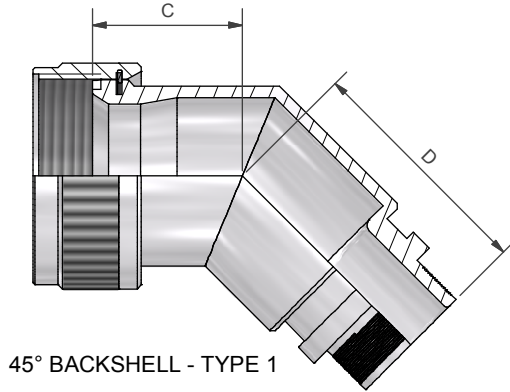

45° BACKSHELL - TYPE 1

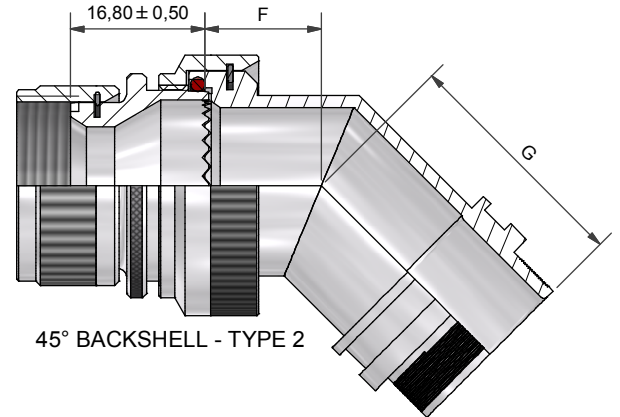

45° BACKSHELL - TYPE 2

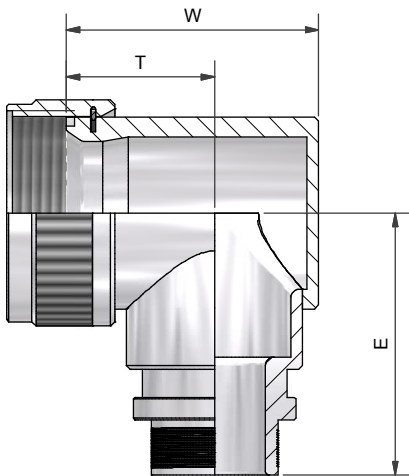

90° BACKSHELL - TYPE 1

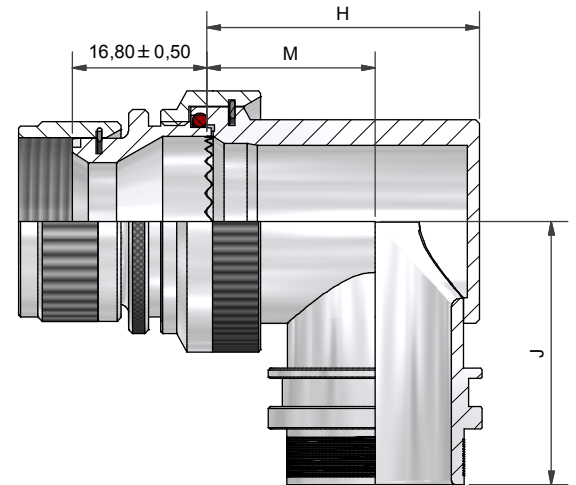

90° BACKSHELL - TYPE 2

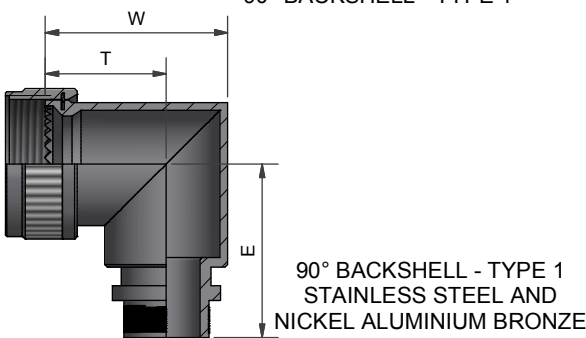

90° BACKSHELL - TYPE 1
STAINLESS STEEL AND
NICKEL ALUMINIUM BRONZE

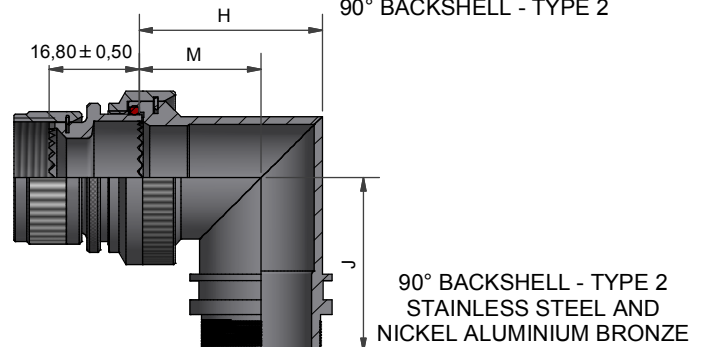

90° BACKSHELL - TYPE 2
STAINLESS STEEL AND
NICKEL ALUMINIUM BRONZE

DRAWN	K.WINCZURA	DATE	01/12/2014
CHECKED		DATE	01/12/2014
APPROVED	K.SHEPPARD	DATE	04/12/2014
APPROVED			

3RD ANGLE PROJECTION NOT TO SCALE

UNLESS OTHERWISE SPECIFIED ALL DIMENSIONS IN MILLIMETRES

GENERAL TOL
LINEAR +/-0.25MM
ANGULAR +/- 1°

TITLE: TINEL-LOCK BACKSHELL

ASSY USED ON: MIL-DTL-26482 SERIES II / MIL-DTL-83723 SERIES I & III

REVISIONS			
LTR	DESCRIPTION	DATE	APPROVED
K	REVISED PER ECO-15-002312	13.02.15	H.SMITH
L	REVISED PER ECO-17-009011	21.06.17	D.JONES

TE CAGE CODE: 06090
POLAMCO/TE CAGE CODE: U5792

TE CONNECTIVITY - POLAMCO LTD RESERVES THE RIGHT TO AMEND THIS DRAWING AND THE INFORMATION SET FORTH HEREON AT ANY TIME. USERS SHOULD INDEPENDENTLY EVALUATE THE SUITABILITY OF THE PRODUCT FOR THEIR APPLICATION.

Polamco

TE connectivity

DRAWING NO:	DRAWING REV:	SHT
TXR54	L	2

MODIFICATION S (SELF-LOCKING COUPLING NUT)

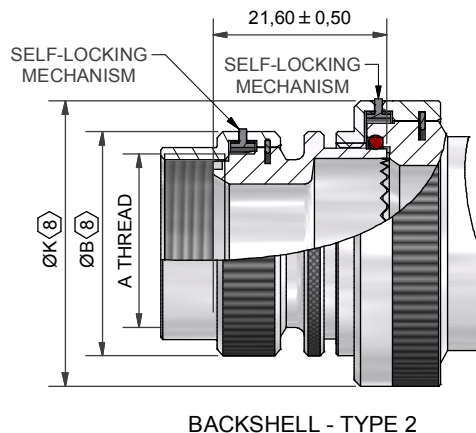
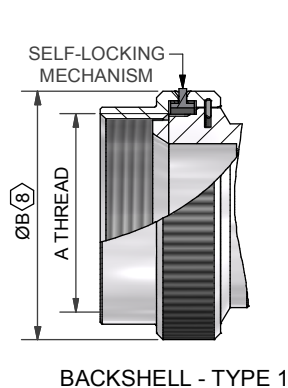

TABLE 1

ORDER NO.	SHELL SIZE		A THREAD	ØB MAX	ØB MAX (8)	MAX ENTRY	C ±0,5	D ±0,5	W ±0,5	T ±0,5	E ±0,5	THESE DIMENSIONS APPLY IF BACKSHELL IS STAINLESS STEEL OR NICKEL ALUMINIUM BRONZE		
	(6)	(7)										W ±0,5	T ±0,5	E ±0,5
03	3		9/16-24 UNEF	17,0	19,4	04	16,8	27,0	26,4	17,8	25,9	26,3	16,0	25,9
08		8 & 8S	1/2-20 UNF	15,6	18,0	04	16,6	26,8	24,5	17,5	26,2	22,4	17,5	26,2
10		10, 10S, 10SL	5/8-24 UNEF	18,6	21,0	06	16,8	27,5	26,5	17,8	28,0	25,0	18,8	28,0
12	7	12 & 12S	3/4-20 UNEF	21,7	25,0	08	17,3	28,0	29,0	18,7	29,5	28,3	20,4	29,5
14	12	14 & 14S	7/8-20 UNEF	24,9	28,0	08	18,1	29,0	30,5	19,0	30,3	30,4	21,5	31,0
16	19	16 & 16S	1-20 UNEF	28,2	31,0	10	19,0	29,7	34,0	21,0	32,7	33,5	23,0	32,7
18	27	18	1 1/16-18 UNEF	30,9	34,0	12	19,2	30,5	37,0	23,5	32,7	35,5	24,0	32,7
20	37	20	1 3/16-18 UNEF	34,1	36,5	14	20,1	30,9	42,0	27,0	34,3	38,8	25,7	34,3
22		22	1 5/16-18 UNEF	37,3	39,8	16	20,3	31,1	44,0	27,0	35,8	41,9	27,2	35,8
24		24	1 7/16-18 UNEF	40,4	42,0	18	21,8	32,1	45,0	27,0	37,4	44,8	28,7	37,4
28		28	1 3/4-18UNS	50,0	49,8	22	23,3	32,5	54,2	31,4	41,9	50,7	31,6	41,9
32		32	2-18 UNS	56,3	57,2	24	25,0	29,3	60,9	36,4	45,3	60,0	33,5	45,3
36		36	2 1/4-16 UN	62,7	63,6	28	26,2	30,7	67,2	38,0	48,4	65,5	36,0	48,4
40		40	2 1/2-16 UN	69,0	70,0	28	28,6	32,0	73,2	41,0	51,4	72,0	39,3	51,4
44		44	2 3/4-16 UN	75,4	75,4	28	30,1	33,7	79,5	44,1	54,6	75,5	40,8	54,6
48		48	3-16UN	81,7	81,7	28	31,3	34,9	85,8	47,2	57,7	75,5	40,8	57,7
61	61		1 1/2-18 UNEF	42,0	43,6	18	22,1	26,6	47,8	28,0	38,7	48,3	27,0	38,7

TABLE 2

ENTRY SIZE	ØZ MIN	ØS	ØY ± 0,3	ØK MAX	ØK MAX (8)	F ±0,5	G ±0,5	H ±0,5	M ±0,5	J ±0,5	THESE DIMENSIONS APPLY IF BACKSHELL IS STAINLESS STEEL OR NICKEL ALUMINIUM BRONZE			
											H ±0,5	M ±0,5	J ±0,5	
04	6,35	9,49 +/-0,04	14,00	NA	NA	NA	NA	NA	NA	NA	NA	NA	NA	NA
05	7,92	11,06 +/-0,04	15,50	21,0	24,6	12,5	27,5	24,0	15,5	27,95	24,3	17,2	28,2	
06	9,53	12,66 +/-0,04	17,10	21,0	24,6	12,5	27,5	24,0	15,5	27,95	24,3	17,2	28,2	
07	11,10	14,21 +/-0,07	18,70	21,0	24,6	12,5	27,5	24,0	15,5	27,95	24,3	17,2	28,2	
08	12,70	15,81 +/-0,07	20,30	24,5	28,3	13,1	28,0	27,0	17,0	29,45	28,3	19,4	29,7	
10	15,88	18,96 +/-0,08	23,50	29,0	32,4	13,5	29,0	31,0	19,5	31,00	31,1	21,0	31,2	
12	19,05	22,14 +/-0,08	26,70	32,5	35,6	14,5	29,7	34,0	21,0	32,70	34,2	22,8	32,9	
14	22,23	25,30 +/-0,08	29,80	35,5	38,5	15,5	30,5	35,0	20,0	34,25	38,5	25,3	34,5	
16	25,40	28,48 +/-0,08	33,00	37,0	41,7	16,1	30,9	38,0	21,5	35,80	40,7	26,1	36,1	
18	28,58	31,65 +/-0,08	36,20	40,0	43,9	16,5	31,1	42,0	24,0	37,40	43,7	27,6	37,6	
20	31,75	34,83 +/-0,08	39,40	43,5	47,0	17,0	32,1	45,0	25,5	38,90	46,4	29,1	39,1	
22	34,93	37,98 +/-0,08	42,50	48,5	50,0	18,5	35,3	54,5	31,0	42,00	50,0	31,0	42,0	
24	38,10	41,15 +/-0,08	45,70	52,1	56,0	21,9	38,1	58,0	33,0	46,00	53,5	33,0	46,0	
28	44,45	47,50 +/-0,08	52,00	58,5	61,0	26,9	44,4	65,5	36,5	51,1	60,3	36,5	51,1	

DRAWN	K.WINCZURA	DATE	01/12/2014	
CHECKED		DATE	01/12/2014	
APPROVED	K.SHEPPARD	DATE	04/12/2014	UNLESS OTHERWISE SPECIFIED ALL DIMENSIONS IN MILLIMETRES GENERAL TOL LINEAR +/-0,25MM ANGULAR +/- 1°
APPROVED				

TITLE:

TINEL-LOCK BACKSHELL

ASSY USED ON:

MIL-DTL-26482 SERIES II / MIL-DTL-83723 SERIES I & III



Polamco



REVISIONS			
LTR	DESCRIPTION	DATE	APPROVED
K	REVISED PER ECO-15-002312	13.02.15	H.SMITH
L	REVISED PER ECO-17-009011	21.06.17	D.JONES

TE CAGE CODE: 06090
POLAMCO/TE CAGE CODE: U5792

TE CONNECTIVITY - POLAMCO LTD RESERVES THE RIGHT TO AMEND THIS DRAWING AND THE INFORMATION SET FORTH HEREON AT ANY TIME. USERS SHOULD INDEPENDENTLY EVALUATE THE SUITABILITY OF THE PRODUCT FOR THEIR APPLICATION.



DRAWING NO:
TXR54

DRAWING REV:
L

SHT
3

Looking for pricing, stock, or lifecycle information?

Click below to explore more details on WIN SOURCE:

-  [View TXR54AB00-1606AI-CS1000 on WIN SOURCE](#)
-  [TE Connectivity Information](#)

Optimize Your Supply Chain with WIN SOURCE Solutions

-  Global Sourcing Solution
-  Obsolete Management
-  Cost Control Management
-  Shortage Management
-  Alternative Solution
-  Excess Inventory Management