

CNZ3731, CNC7C501, CNZ3734, CNC2S501, CNC7C502, CNC7H501 (ON3731, ON3732, ON3734, ON3731A, ON3732A, ON3734A)

Optoisolators

Overview

The CNZ3731 series of optoisolators consist of a GaAs infrared LED which is optically coupled with a Si NPN Darlington phototransistor, and housed in a small DIL package. The series provides high I/O isolation voltage and high collector/emitter isolation voltage, as well as a high current transfer ratio (CTR). This opto isolator series also includes the two-channel CNC7C501 and the four-channel CNZ3734, and A type of these models with increased collector to emitter breakdown voltage ($V_{CEO} > 350V$).

Features

- High collector to emitter breakdown voltage : $V_{CEO} > 300 V$,
A type : $V_{CEO} > 350 V$
- High current transfer ratio with Darlington phototransistor output :
CTR = 4000% (typ.)
- High I/O isolation voltage : $V_{ISO} \geq 5000 V_{rms}$
- Small DIL package for saving mounting space
- UL listed (UL File No. E79920)
- A-type models have a guaranteed internal insulating distance of 0.4 mm

Applications

- Telephones
- Telephone exchange
- FAX
- Programmable controllers
- Signal transfer between circuits with different potentials and impedances

Pin Connection

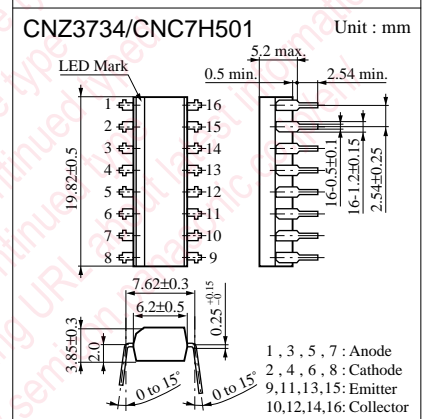
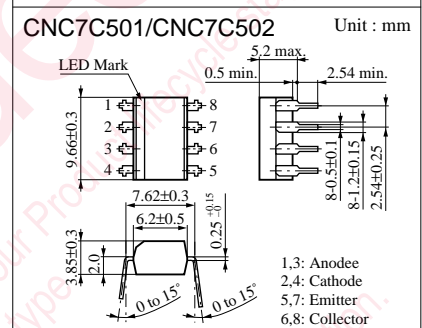
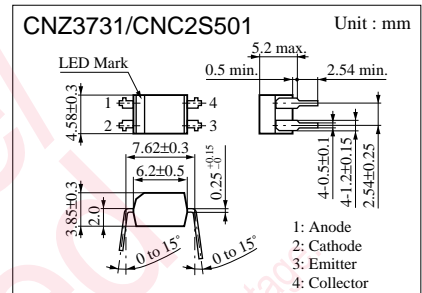
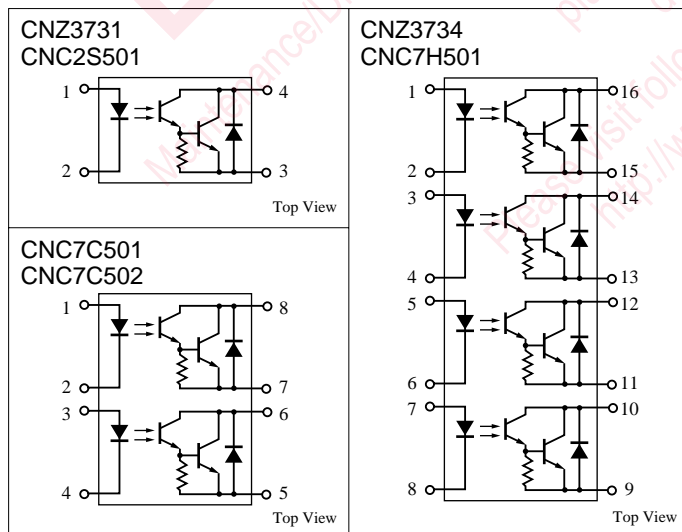

(Note) The part numbers in the parenthesis show conventional part number.

Absolute Maximum Ratings (Ta = 25°C)

Parameter		Symbol	Ratings				Unit
			CNZ3731	CNC7C501 CNZ3734	CNC2S501	CNC7C502 CNC7H501	
Input (Light emitting diode)	Reverse voltage (DC)	V_R	6		6		V
	Forward current (DC)	I_F	50		50		mA
	Pulse forward current	I_{FP}^{*1}	1		1		A
	Power dissipation	P_D^{*2}	75		75		mW
Output (Photo transistor)	Collector current	I_C	150		150		mA
	Collector to emitter voltage	V_{CEO}	300		350		V
	Emitter to collector voltage	V_{ECO}	0.3		0.3		V
	Collector power dissipation	P_C^{*3}	300	150	300	150	mW
Total power dissipation		P_T	320	200	320	200	mW
Isolation voltage, input to output		V_{ISO}^{*4}	5000		5000		V_{rms}
Operating ambient temperature		T_{opr}	-30 to +100		-30 to +100		°C
Storage temperature		T_{stg}	-55 to +125		-55 to +125		°C

*1 Pulse width $\leq 100 \mu s$, repeat 100 pps

*2 Input power derating ratio is 0.75 mW/°C at $T_a \geq 25^\circ C$.

*3 Output power derating ratio is 3.0 mW/°C at $T_a \geq 25^\circ C$ (CNZ3731, CNC2S501).

Output power derating ratio is 0.75 mW/°C at $T_a \geq 25^\circ C$ (CNC7C501, CNC2S502, CNZ3734, CNC7H501).

*4 AC 1min., RH < 60 %

Electrical Characteristics (Ta = 25°C)

Parameter		Symbol	Conditions	min	typ	max	Unit
Input characteristics	Reverse current (DC)	I_R	$V_R = 3V$			10	μA
	Forward voltage (DC)	V_F	$I_F = 50mA$		1.35	1.5	V
	Capacitance between pins	C_t	$V_R = 0V, f = 1MHz$		30		pF
Output characteristics	Collector cutoff current	I_{CEO}	$V_{CE} = 200V$			200	nA
	Collector to emitter capacitance	C_C	$V_{CE} = 10V, f = 1MHz$		10		pF
Transfer characteristics	DC current transfer ratio	CTR^{*1}	$V_{CE} = 2V, I_F = 1mA$	1000	4000		%
	Isolation capacitance, input to output	C_{ISO}	$f = 1MHz$		0.7		pF
	Isolation resistance, input to output	R_{ISO}	$V_{ISO} = 500V$	10^{11}			Ω
	Rise time	t_r^{*2}	$V_{CC} = 10V, I_C = 10mA,$		40		μs
	Fall time	t_f^{*3}	$R_t = 100\Omega$		15		μs
Collector to emitter saturation voltage		$V_{CE(sat)}$	$I_F = 1mA, I_C = 2mA$			1.0	V

*1 DC current transfer ratio (CTR) is a ratio of output current against DC input current.

$$CTR = \frac{I_C}{I_F} \times 100 (\%)$$

*2 t_r : Time required for the collector current to increase from 10% to 90% of its final value

*3 t_f : Time required for the collector current to decrease from 90% to 10% of its initial value

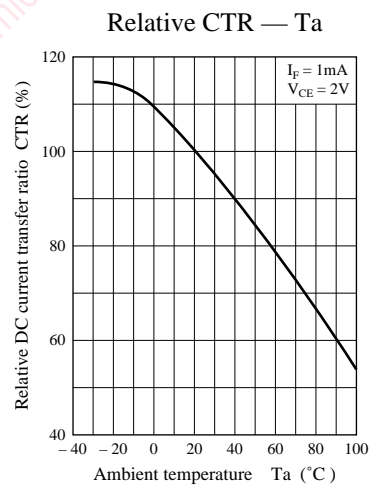
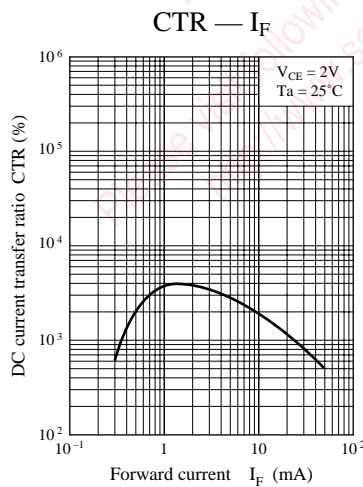
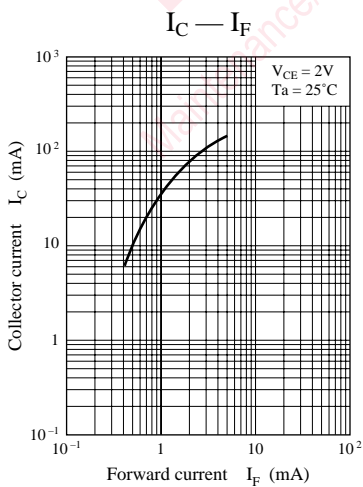
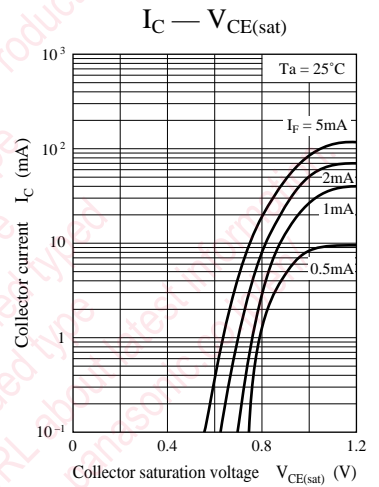
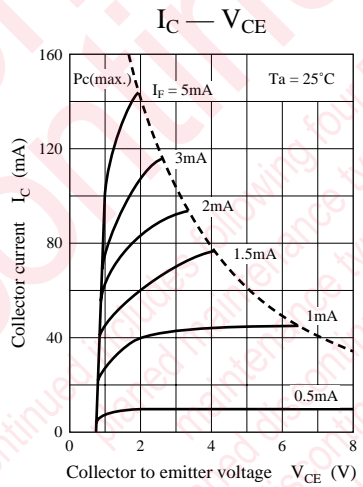
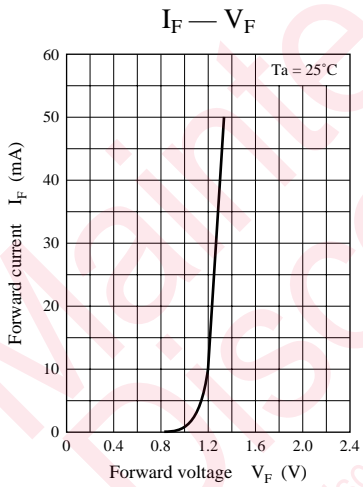
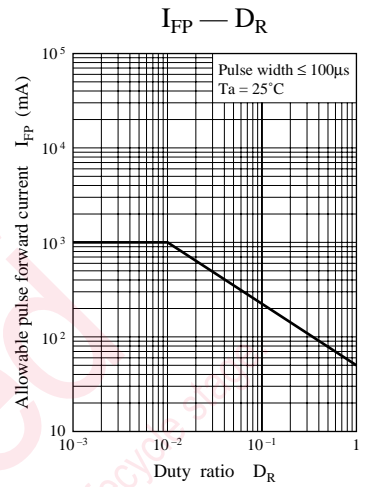
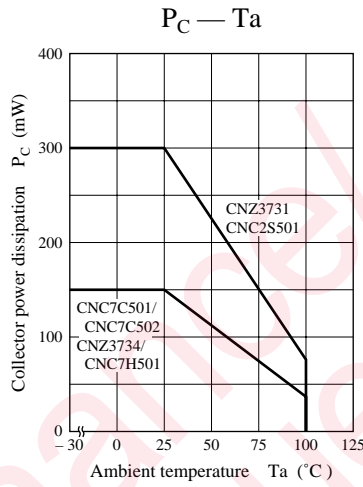
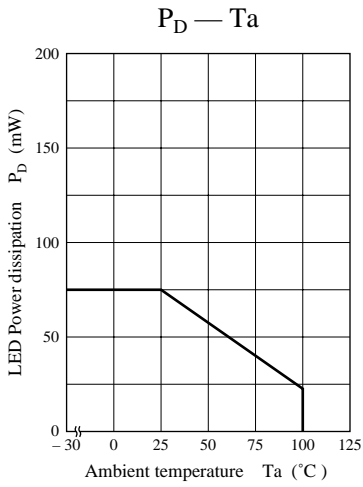

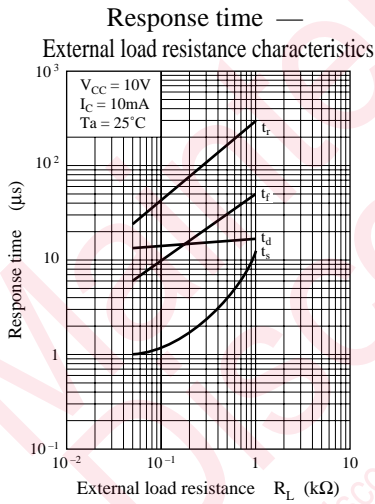
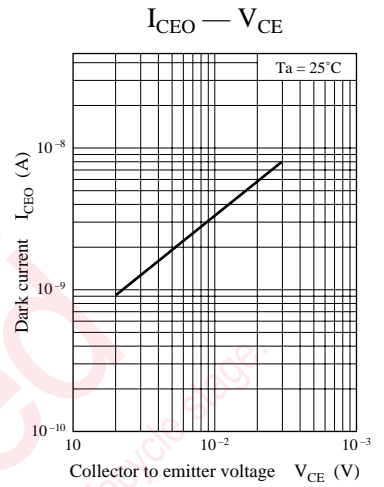
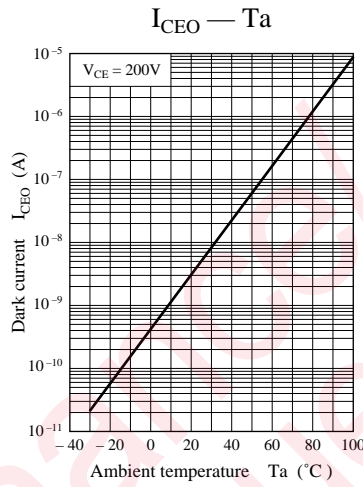
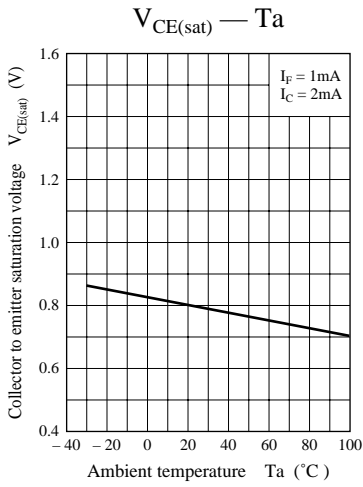

Response time measurement circuit

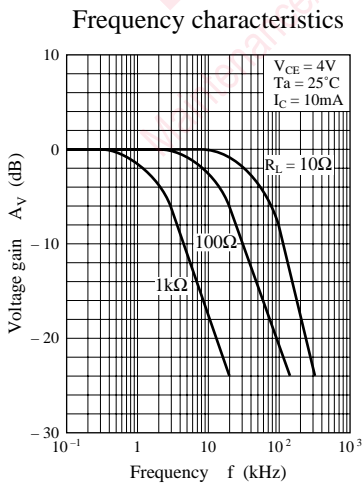
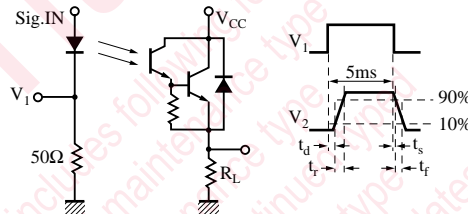

Measurement circuit of frequency characteristics

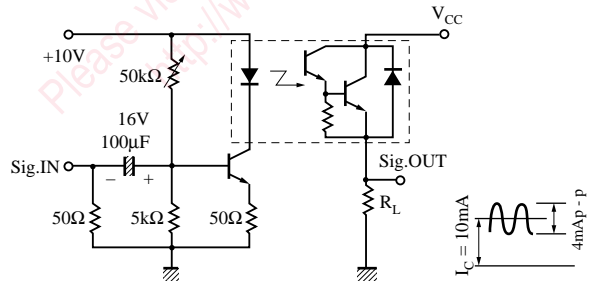

for Safety

contains Gallium Arsenide (GaAs).

vapor are hazardous to human health if inhaled or
burn, destroy, cut, cleave off, or chemically dissolve the
stated laws and ordinances for disposal. The product
from general industrial waste or household garbage.

utions in using the technical information and described in this book

s book is to be exported or provided to non-residents, the laws and
rd to security export control, must be observed.

ly to show the main characteristics and application circuit examples
l property right or other right owned by our company or any other
any as to the infringement upon any such right owned by any other
rmation described in this book.

standard applications or general electronic equipment (such as office
and household appliances).

ng applications:

biles, traffic control equipment, combustion equipment, life support
reliability are required, or if the failure or malfunction of the prod-

ck are subject to change without notice for modification and/or im-
use of the products, therefore, ask for the most up-to-date Product
atisfy your requirements.

bsolute maximum rating and the guaranteed operating conditions
.). Especially, please be careful not to exceed the range of absolute
er-off and mode-switching. Otherwise, we will not be liable for any

, take into the consideration of incidence of break down and failure
n the systems such as redundant design, arresting the spread of fire
al injury, fire, social damages, for example, by using the products.

own and characteristics change due to external factors (ESD, EOS,
mounting or at customer's process. When using products for which
shelf life and the elapsed time since first opening the packages.

ly or partially, without the prior written permission of Matsushita

ook or our semiconductor products, please contact one
ctor Company's Department.







Looking for pricing, stock, or lifecycle information?

Click below to explore more details on WIN SOURCE:

 [View CNZ3731 on WIN SOURCE](#)

 [Panasonic Information](#)

Optimize Your Supply Chain with WIN SOURCE Solutions

-  Global Sourcing Solution
-  Obsolete Management
-  Cost Control Management
-  Shortage Management
-  Alternative Solution
-  Excess Inventory Management