



**THE DATASHEET OF
CLC5957MTDX/NOPB**



CLC5957 12-Bit, 70 MSPS Broadband Monolithic A/D Converter

Check for Samples: [CLC5957](#)

FEATURES

- **70MSPS**
- **Wide Dynamic Range:**
 - SFDR: 74dBc
 - SFDR with Wither: 85dBFS
 - SNR: 67dB
- **IF Sampling Capability**
- **Input Bandwidth = 0-300MHz**
- **Low Power Dissipation: 640mW**
- **Very Small Package: 48-pin TSSOP**
- **Single +5V Supply**
- **Data Valid Clock Output**
- **Programmable Output Levels: 3.3V or 2.5V**

APPLICATIONS

- **Cellular Base Stations**
- **Digital Communications**
- **Infrared/CCD Imaging**
- **IF Sampling**
- **Electro-optics**
- **Instrumentation**
- **Medical Imaging**
- **High Definition Video**

DESCRIPTION

The CLC5957 is a monolithic 12-bit, 70MSPS analog-to-digital converter. The device has been optimized for use in IF-sampled digital receivers and other applications where high resolution, high sampling rate, wide dynamic range, low power dissipation, and compact size are required. The CLC5957 features differential analog inputs, low jitter differential universal clock inputs, a low distortion track-and-hold with 0-300MHz input bandwidth, a bandgap voltage reference, data valid clock output, TTL compatible CMOS (3.3V or 2.5V) programmable output logic, and a proprietary 12-bit multi-stage quantizer. The CLC5957 is fabricated on the ABIC-V 0.8 micron BiCMOS process.

The CLC5957 features a 74dBc spurious free dynamic range (SFDR) and a 67dB signal to noise ratio (SNR). The wideband track-and-hold allows sampling of IF signals to greater than 250MHz. The part produces two-tone, dithered, SFDR of 83dBFS at 75MHz input frequency. The differential analog input provides excellent common mode rejection, while the differential universal clock inputs minimize jitter. The 48-pin TSSOP package provides an extremely small footprint for applications where space is a critical consideration. The CLC5957 operates from a single +5V power supply. Operation over the industrial temperature range of -40°C to +85°C is specified. Each part is tested to verify compliance with the ensured specifications.

Block Diagram

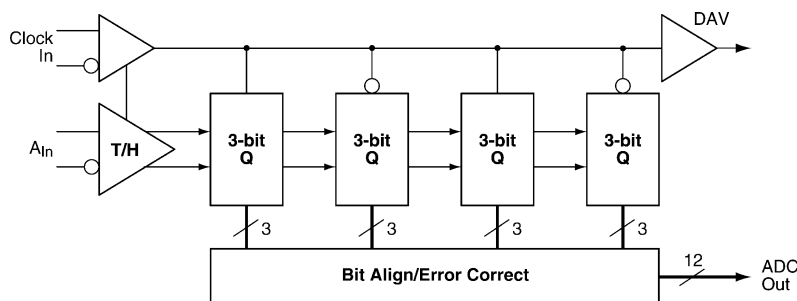

Please be aware that an important notice concerning availability, standard warranty, and use in critical applications of Texas Instruments semiconductor products and disclaimers thereto appears at the end of this data sheet.

All trademarks are the property of their respective owners.

Pin Configuration

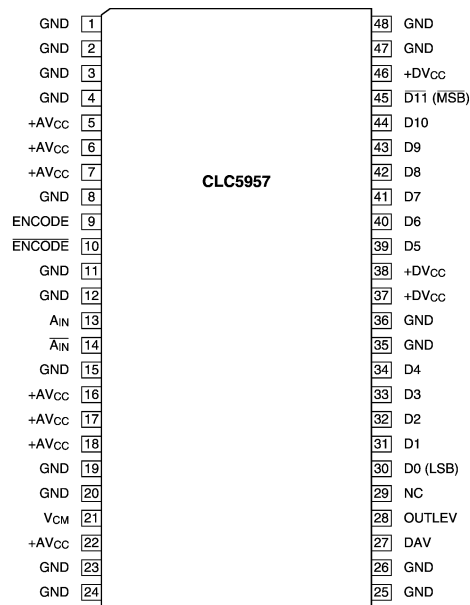

Figure 1. 48 Pin TSSOP
See Package Number DGG

PIN DESCRIPTIONS

Pin Name	Pin No.	Description
$\overline{A_{IN}}$ A_{IN}	13, 14	Differential input with a common mode voltage of +2.4V. The ADC full scale input is 1.024 V_{PP} on each of the complimentary input signals.
\overline{ENCODE} ENCODE	9, 10	Differential clock where ENCODE initiates a new data conversion cycle on each rising edge. Logic for these inputs are a 50% duty cycle universal differential signal (>200mV). The clock input is internally biased to $V_{CC}/2$ with a termination impedance of 2.5k Ω .
V_{CM}	21	Internal common mode voltage reference. Nominally +2.4V. Can be used for the input common mode voltage. This voltage is derived from an internal bandgap reference. V_{CM} should be buffered when driving any external load. Failure to buffer this signal can cause errors in the internal bias currents.
$\overline{D0-D11}$	30–34, 39–45	Digital data outputs are CMOS and TTL compatible. D0 is the LSB and D11 is the MSB. MSB is inverted. Output coding is two's complement. Current limited to source/sink 2.5mA typical.
GND	1–4, 8, 11, 12, 15, 19, 20, 23–26, 35, 36, 47, 48	Circuit ground.
+AV _{CC}	5–7, 16–18, 22	+5V power supply for the analog section. Bypass to ground with a 0.1 μ F capacitor.
+DV _{CC}	37, 38, 46	+5V power supply for the digital section. Bypass to ground with a 0.1 μ F capacitor.
NC	29	No connect. May be left open or grounded.
DAV	27	Data Valid Clock. Data is valid on rising edge. Current limited to source/sink 5mA typical.
OUTLEV	28	Output Logic 3.3V or 2.5V option. Open = 3.3V, GND = 2.5V.



These devices have limited built-in ESD protection. The leads should be shorted together or the device placed in conductive foam during storage or handling to prevent electrostatic damage to the MOS gates.

Absolute Maximum Ratings⁽¹⁾⁽²⁾

Positive Supply Voltage (V_{CC})		-0.5V to +6V
Differential Voltage between any two Grounds		<100 mV
Analog Input Voltage Range		GND to V_{CC}
Digital Input Voltage Range		-0.5V to + V_{CC}
Output Short Circuit Duration (one-pin to ground)		Infinite
Junction Temperature ⁽³⁾		175°C
Storage Temperature Range		-65°C to +150°C
Lead Solder Duration (+300°C)		10 sec.
ESD tolerance	Human Body Model	2000V
	Machine Model	200V

- (1) "Absolute Maximum Ratings" are limiting values, to be applied individually, and beyond which the serviceability of the circuit may be impaired. Functional operability under any of these conditions is not necessarily implied. Exposure to maximum ratings for extended periods may affect device reliability.
- (2) If Military/Aerospace specified devices are required, please contact the Texas Instruments Sales Office/ Distributors for availability and specifications.
- (3) The absolute maximum junction (T_{Jmax}) temperature for this device is 175°C. The maximum allowable power dissipation is dictated by T_{Jmax} , the junction-to-ambient thermal resistance (θ_{JA}), and the ambient temperature (T_A), and can be calculated using the formula $P_{Dmax} = (T_{Jmax} - T_A)/\theta_{JA}$. For the 48-pin TSSOP, θ_{JA} is 56°C/W, so $P_{Dmax} = 2.68W$ at 25°C and 1.6W at the maximum operating ambient temperature of 85°C. Note that the power dissipation of this device under normal operation will typically be about 650 mW (640 mW quiescent power + 10 mW due to 1 TTL load on each digital output). The values of absolute maximum power dissipation will only be reached when the CLC5957 is operated in a severe fault condition (e.g., when input or output pins are driven beyond the power supply voltages, or the power supply polarity is reversed). Obviously, such conditions should always be avoided.

Recommended Operating Conditions

Positive Supply Voltage (V_{CC})	+5V ±5%
Analog Input Voltage Range	2.048 V_{PP} diff.
Operating Temperature Range	-40°C to +85°C

Package Thermal Resistance⁽¹⁾

Package	θ_{JA}	θ_{JC}
48-Pin TSSOP	56°C/W	16°C/W

- (1) The absolute maximum junction (T_{Jmax}) temperature for this device is 175°C. The maximum allowable power dissipation is dictated by T_{Jmax} , the junction-to-ambient thermal resistance (θ_{JA}), and the ambient temperature (T_A), and can be calculated using the formula $P_{Dmax} = (T_{Jmax} - T_A)/\theta_{JA}$. For the 48-pin TSSOP, θ_{JA} is 56°C/W, so $P_{Dmax} = 2.68W$ at 25°C and 1.6W at the maximum operating ambient temperature of 85°C. Note that the power dissipation of this device under normal operation will typically be about 650 mW (640 mW quiescent power + 10 mW due to 1 TTL load on each digital output). The values of absolute maximum power dissipation will only be reached when the CLC5957 is operated in a severe fault condition (e.g., when input or output pins are driven beyond the power supply voltages, or the power supply polarity is reversed). Obviously, such conditions should always be avoided.

Reliability Information

Transistor Count	5000
------------------	------

Converter Electrical Characteristics

The following specifications apply for $AV_{CC} = DV_{CC} = +5V$, 66MSPS. **Boldface limits apply for $T_A = T_{min} = -40°C$ to $T_{max} = +85°C$** , all other limits $T_A = 25°C$ ⁽¹⁾.

Symbol	Parameter	Conditions	Min	Typ	Max	Units
DYNAMIC PERFORMANCE						
BW	Large-Signal Bandwidth	$A_{IN} = -3$ dBFS		300		MHz
	Overvoltage Recovery Time	$A_{IN} = 1.5$ FS (0.01%)		12		ns
t_A	Effective Aperture Delay			-0.41		ns
t_{AJ}	Aperture Jitter			0.3		ps(rms)

- (1) Typical specifications are based on the mean test values of deliverable converters from the first three diffusion lots.

Converter Electrical Characteristics (continued)

The following specifications apply for $AV_{CC} = DV_{CC} = +5V$, 66MSPS. **Boldface limits apply for $T_A = T_{min} = -40^{\circ}C$ to $T_{max} = +85^{\circ}C$** , all other limits $T_A = 25^{\circ}C^{(1)}$.

Symbol	Parameter	Conditions	Min	Typ	Max	Units
NOISE AND DISTORTION						
SNR ^{*(2)}	Signal-to-Noise Ratio (without 50 harmonics)	$f_{IN} = 5 \text{ MHz}, A_{IN} = -1\text{dBFS}$		67		dBFS
		$f_{IN} = 25 \text{ MHz}, A_{IN} = -1\text{dBFS}^*$	60	66		dBFS
		$f_{IN} = 75 \text{ MHz}, A_{IN} = -3\text{dBFS}$		65		dBFS
		$f_{IN} = 150 \text{ MHz}, A_{IN} = -15\text{dBFS}$		66		dBFS
		$f_{IN} = 250 \text{ MHz}, A_{IN} = -15\text{dBFS}$		66		dBFS
SFDR	Spurious-Free Dynamic Range	$f_{IN} = 5 \text{ MHz}, A_{IN} = -1\text{dBFS}$		74		dBc
		$f_{IN} = 25 \text{ MHz}, A_{IN} = -1\text{dBFS}^*$	60	74		dBc
		$f_{IN} = 75 \text{ MHz}, A_{IN} = -3\text{dBFS}$		72		dBc
		$f_{IN} = 150 \text{ MHz}, A_{IN} = -15\text{dBFS}$		69		dBc
	$f_{IN} = 250 \text{ MHz}, A_{IN} = -15\text{dBFS}$		65		dBc	
	Spurious-Free Dynamic Range (dithered)	$f_{IN} = 19 \text{ MHz}, A_{IN} = -6\text{dBFS}$		85		dBFS
IMD	Intermodulation Distortion	$f_{IN1} = 149.84 \text{ MHz}, f_{IN2} = 149.7 \text{ MHz}, A_{IN} = -10\text{dBFS}$		68		dBFS
		$f_{IN1} = 249.86 \text{ MHz}, f_{IN2} = 249.69 \text{ MHz}, A_{IN} = -10\text{dBFS}$		58		dBFS
	Intermodulation Distortion (dithered)	$f_{IN1} = 74 \text{ MHz}, f_{IN2} = 75 \text{ MHz}, A_{IN} = -12\text{dBFS}$		83		dBFS
DC ACCURACY AND PERFORMANCE						
DNL	Differential Non-Linearity	$f_{IN} = 5\text{MHz}, A_{IN} = -1\text{dBFS}$		± 0.65		LSB
INL	Integral Non-Linearity	$f_{IN} = 5\text{MHz}, A_{IN} = -1\text{dBFS}$		± 1.5		LSB
	Offset Error ⁽²⁾		-30	0	30	mV
	Gain Error			1.2		% FS
V_{REF}	Reference Voltage ⁽²⁾		2.2	2.37	2.6	V
	No Missing Codes ⁽²⁾	$f_{IN} = 5\text{MHz}, A_{IN} = -1\text{dBFS}$		Specified		
ANALOG INPUTS						
V_{IN}	Analog Diff Input Voltage Range			2.048		V_{PP}
$R_{IN} \text{ (SE)}$	Analog Input Resistance (Single-Ended)			500		Ω
$R_{IN} \text{ (Diff)}$	Analog Input Resistance (Differential)			1000		Ω
C_{IN}	Analog Input Capacitance (Single-ended)			2		pF
ENCODE INPUTS (UNIVERSAL)						
V_{IH}	Logic Input High Voltage ⁽³⁾⁽⁴⁾				5	V
V_{IL}	Logic Input Low Voltage ⁽³⁾⁽⁴⁾		0			V
	Differential Input Swing ⁽³⁾⁽⁴⁾		0.2			V
DIGITAL OUTPUTS						
V_{OL}	Logic Output Low Voltage ⁽²⁾			0.01	0.4	V
V_{OH}	Logic Output High Voltage ⁽²⁾	OUTLEV = 1 (open)	3.2	3.5	3.8	V
		OUTLEV = 0 (GND)	2.4	2.7	3.0	V

(2) These parameters are ensured by test.

(3) Values specified based on characterization and simulation.

(4) See [Figure 29](#) for ENCODE inputs circuit.

Converter Electrical Characteristics (continued)

The following specifications apply for $AV_{CC} = DV_{CC} = +5V$, 66MSPS. **Boldface limits apply for $T_A = T_{min} = -40^{\circ}C$ to $T_{max} = +85^{\circ}C$** , all other limits $T_A = 25^{\circ}C^{(1)}$.

Symbol	Parameter	Conditions	Min	Typ	Max	Units
TIMING ⁽⁵⁾						
	Maximum Conversion Rate (ENCODE) ⁽⁶⁾		70	75		MSPS
	Minimum Conversion Rate (ENCODE)			10		MSPS
t_P	Pulse Width High (ENCODE) ⁽⁷⁾	50% threshold	7.1			ns
t_M	Pulse Width Low (ENCODE) ⁽⁷⁾	50% threshold	7.1			ns
t_{DNV}	ENCODE falling edge to DATA not valid ⁽⁷⁾		8.3			ns
t_{DGV}	ENCODE falling edge to DATA ensured valid ⁽⁷⁾				17.8	ns
t_{DAV}	Rising ENCODE to rising DAV delay ⁽⁷⁾	50% threshold	8.3		12.6	ns
t_S	DATA setup time before rising DAV ⁽⁷⁾		$t_M - 2.4$			ns
t_H	DATA hold time after rising DAV ⁽⁷⁾		$t_P - 1.6$			ns
	Pipeline latency				3.0	clk cycle
POWER REQUIREMENTS						
I_{CC}	Total Operating Supply Current ⁽⁶⁾			128	150	mA
	Power Dissipation ⁽⁶⁾			640	750	mW
	Power Supply Rejection Ratio			64		dB

(5) $C_L = 7pF$ DATA; $10pF$ DAV.

(6) These parameters are ensured by test.

(7) Values specified based on characterization and simulation.

Typical Performance Characteristics

($A_{V_{CC}} = DV_{CC} = +5V$)

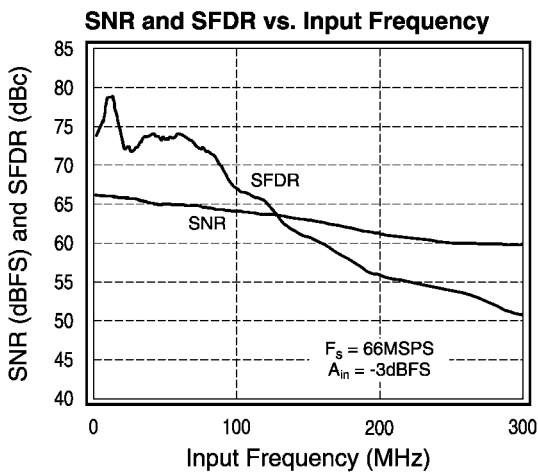

Figure 2.

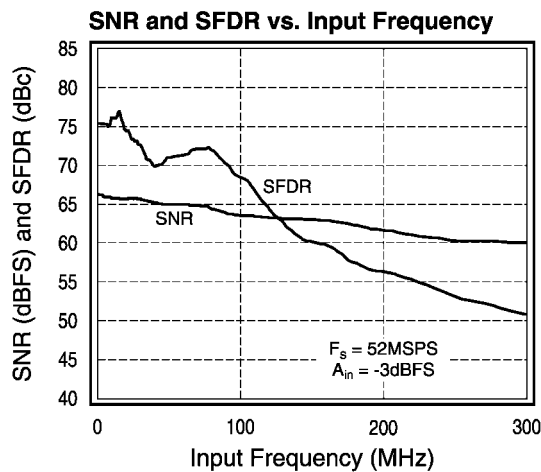

Figure 3.

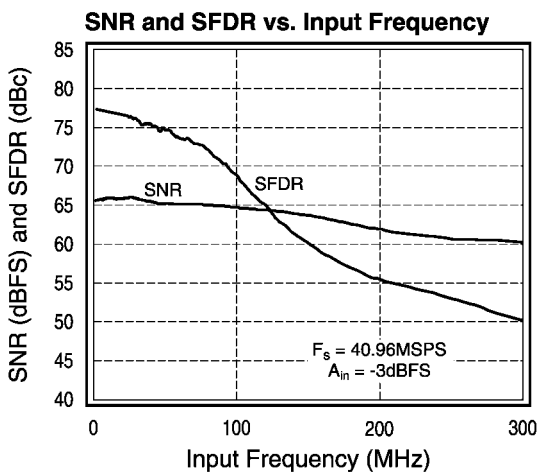

Figure 4.

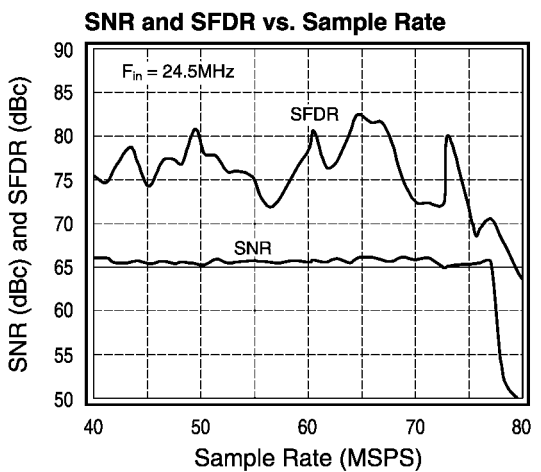

Figure 5.

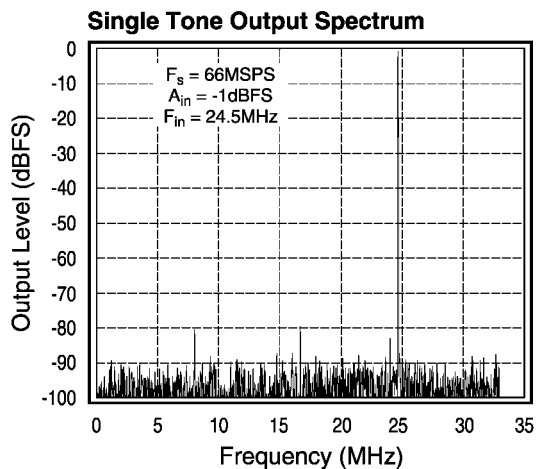

Figure 6.

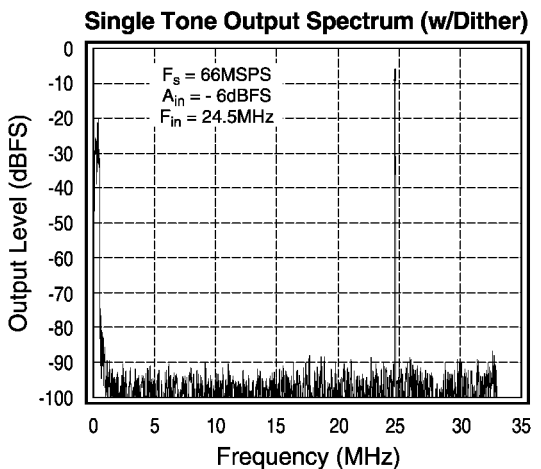

Figure 7.

Typical Performance Characteristics (continued)

($A_{V_{CC}} = DV_{CC} = +5V$)

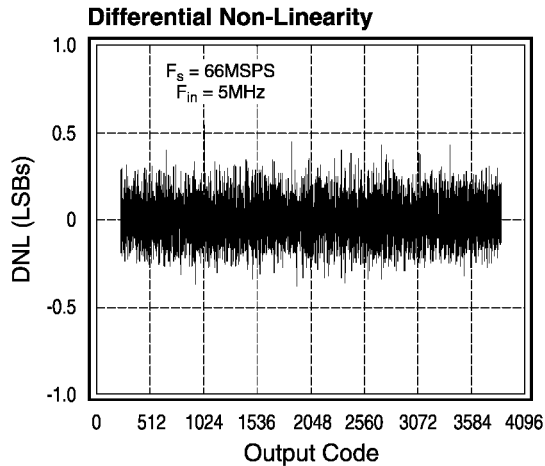

Figure 8.

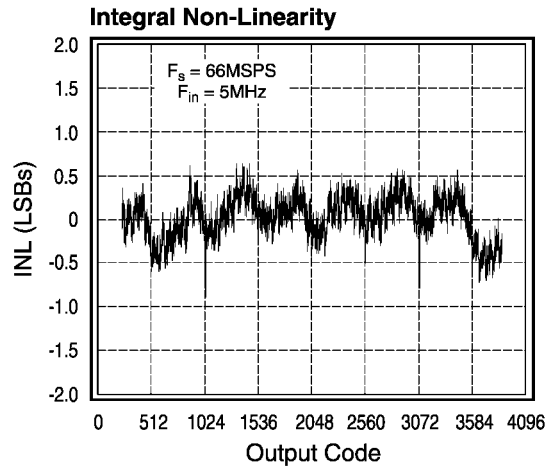

Figure 9.

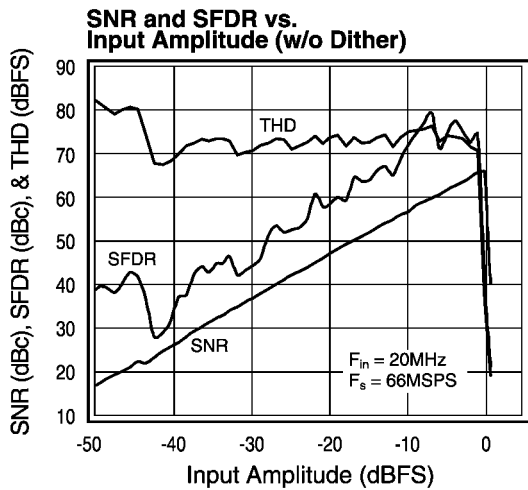

Figure 10.

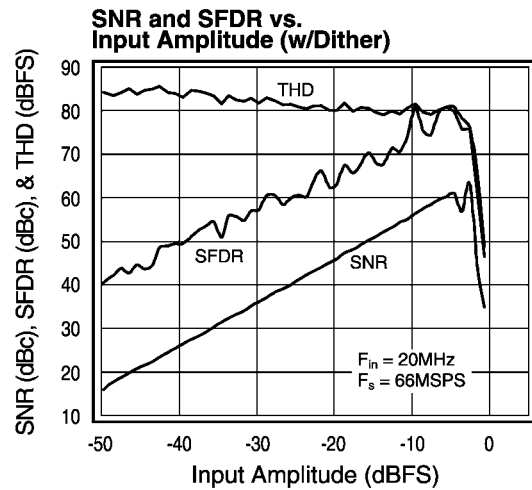

Figure 11.

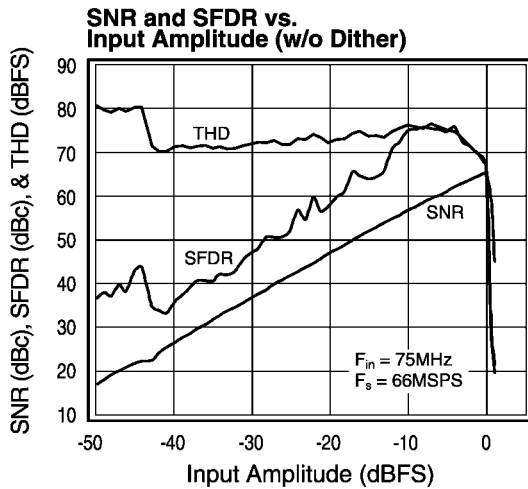

Figure 12.

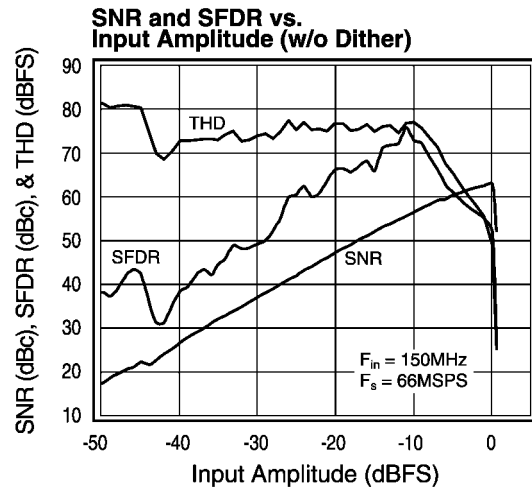

Figure 13.

Typical Performance Characteristics (continued)

($A_{V_{CC}} = DV_{CC} = +5V$)

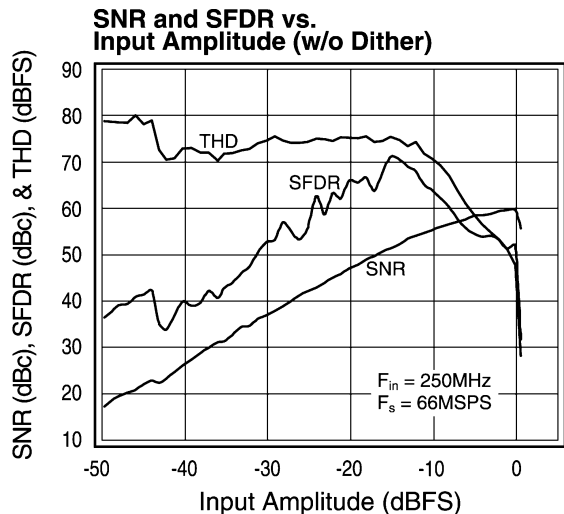

Figure 14.

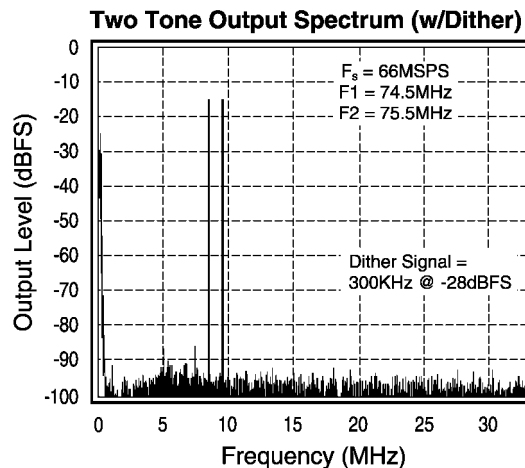

Figure 15.

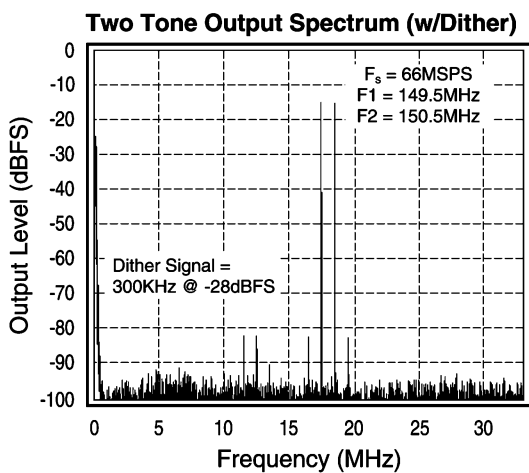

Figure 16.

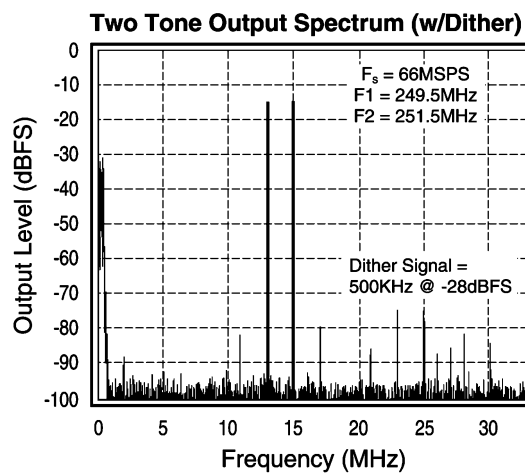

Figure 17.

TIMING DIAGRAMS

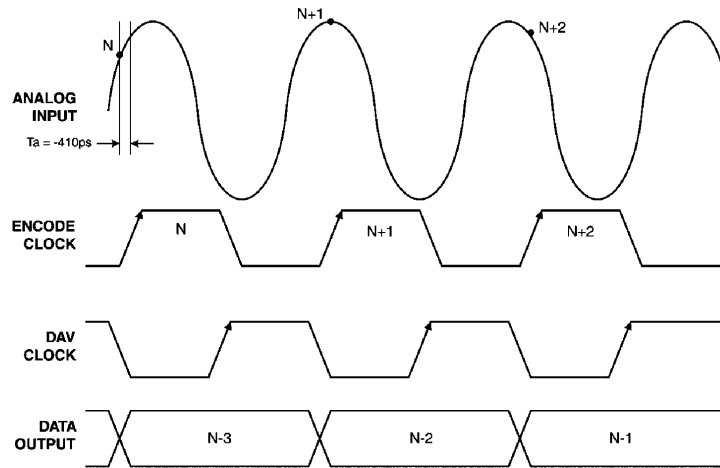

Figure 18. CLC5957 APERTURE DELAY Diagram

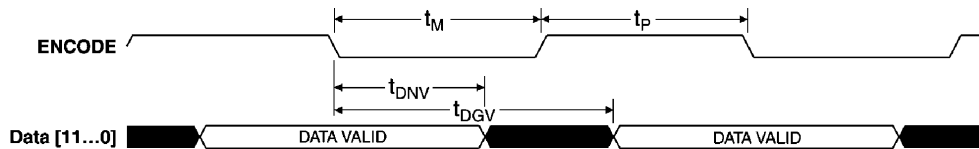

Figure 19. CLC5957 ENCODE to Data Timing Diagram

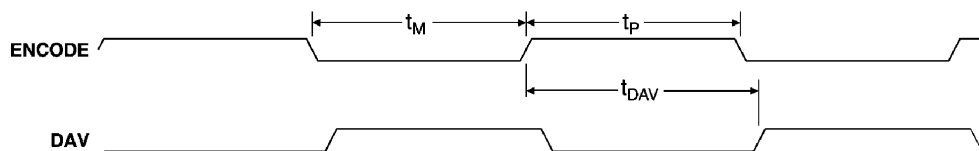

Figure 20. CLC5957 ENCODE to DAV Timing Diagram

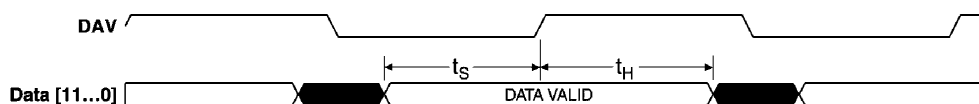
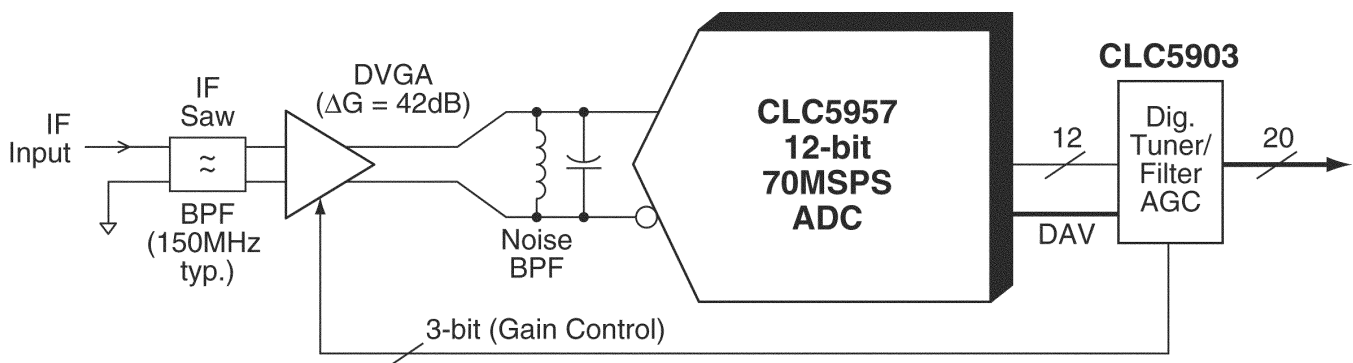
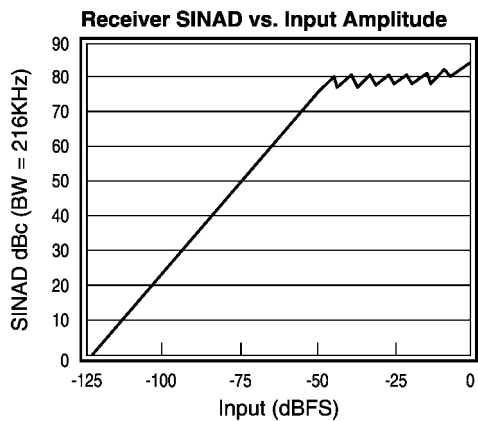

Figure 21. CLC5957 DAV to Data Timing Diagram

Single IF Down Converter (Diversity Receiver Chipset)





Evaluation Board

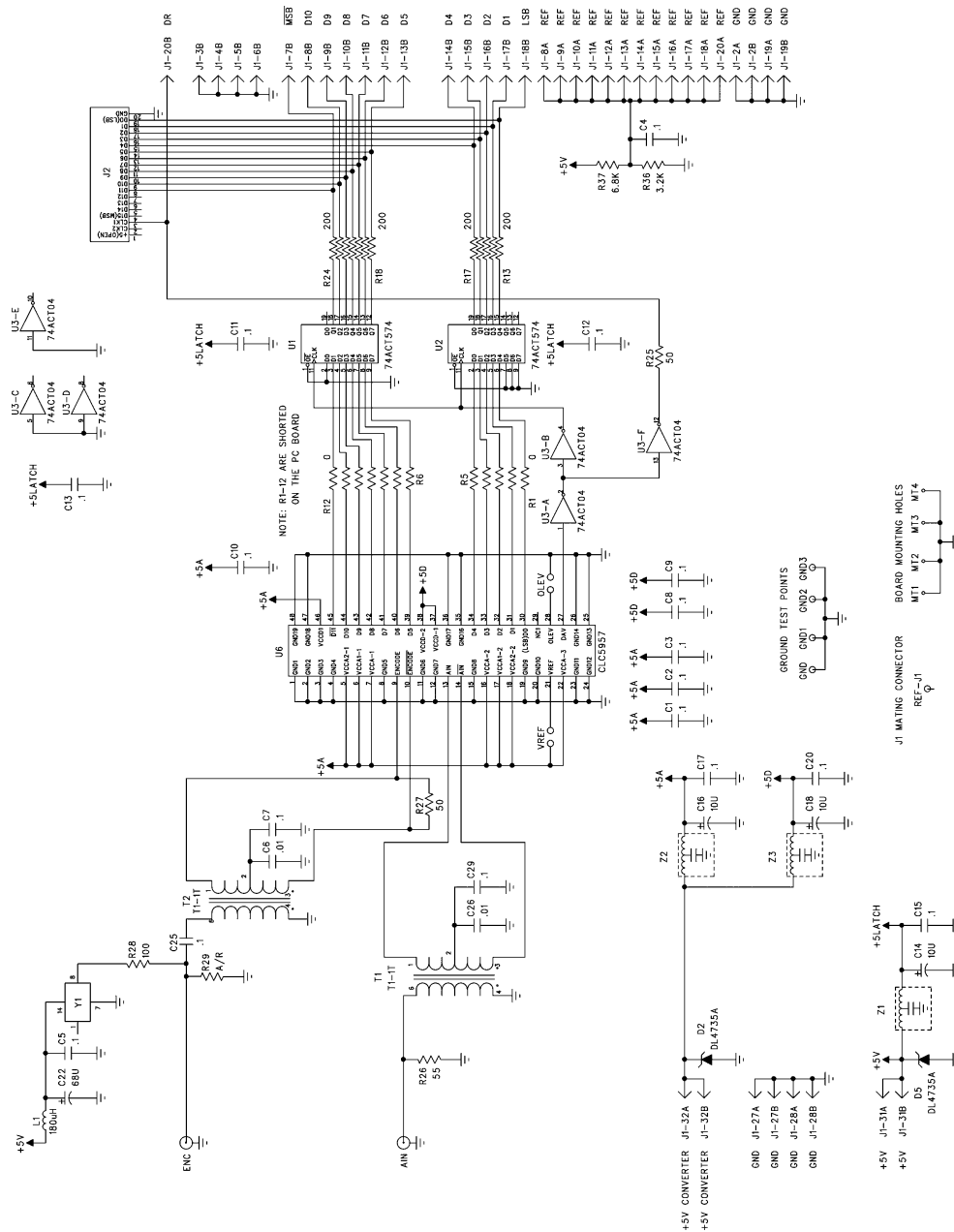

Figure 22. Evaluation Board Schematic

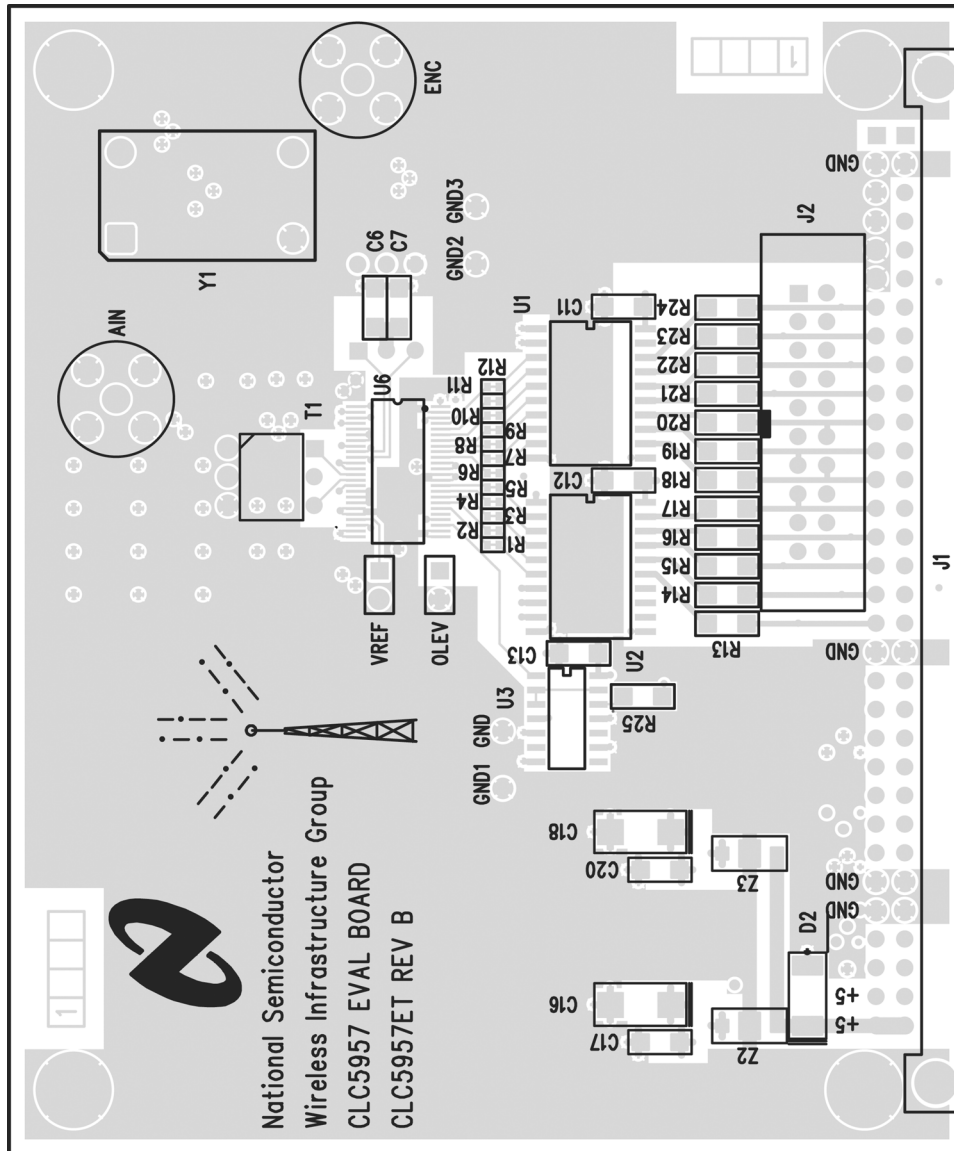

Figure 23. CLC5957PCASM Layer 1

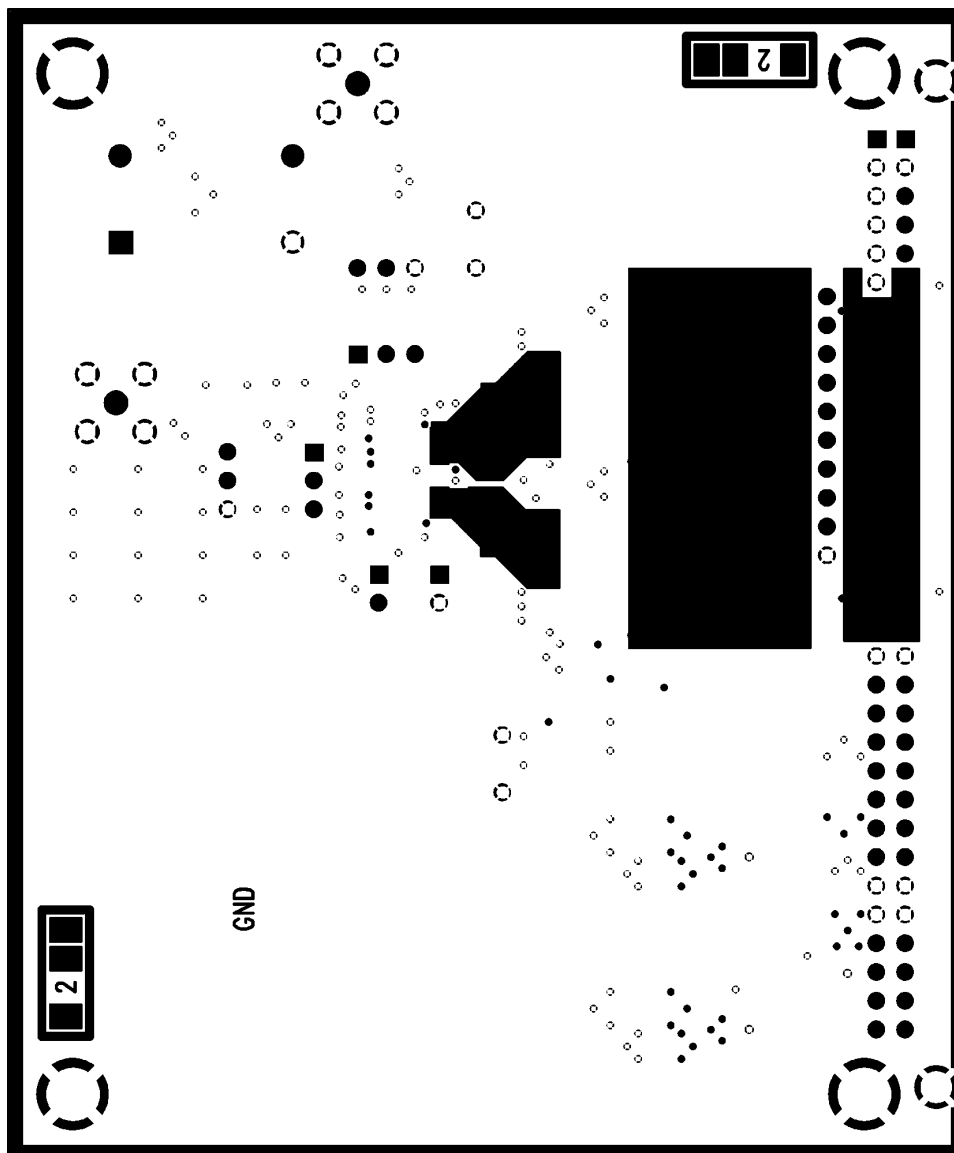

Figure 24. CLC5957PCASM Layer 2

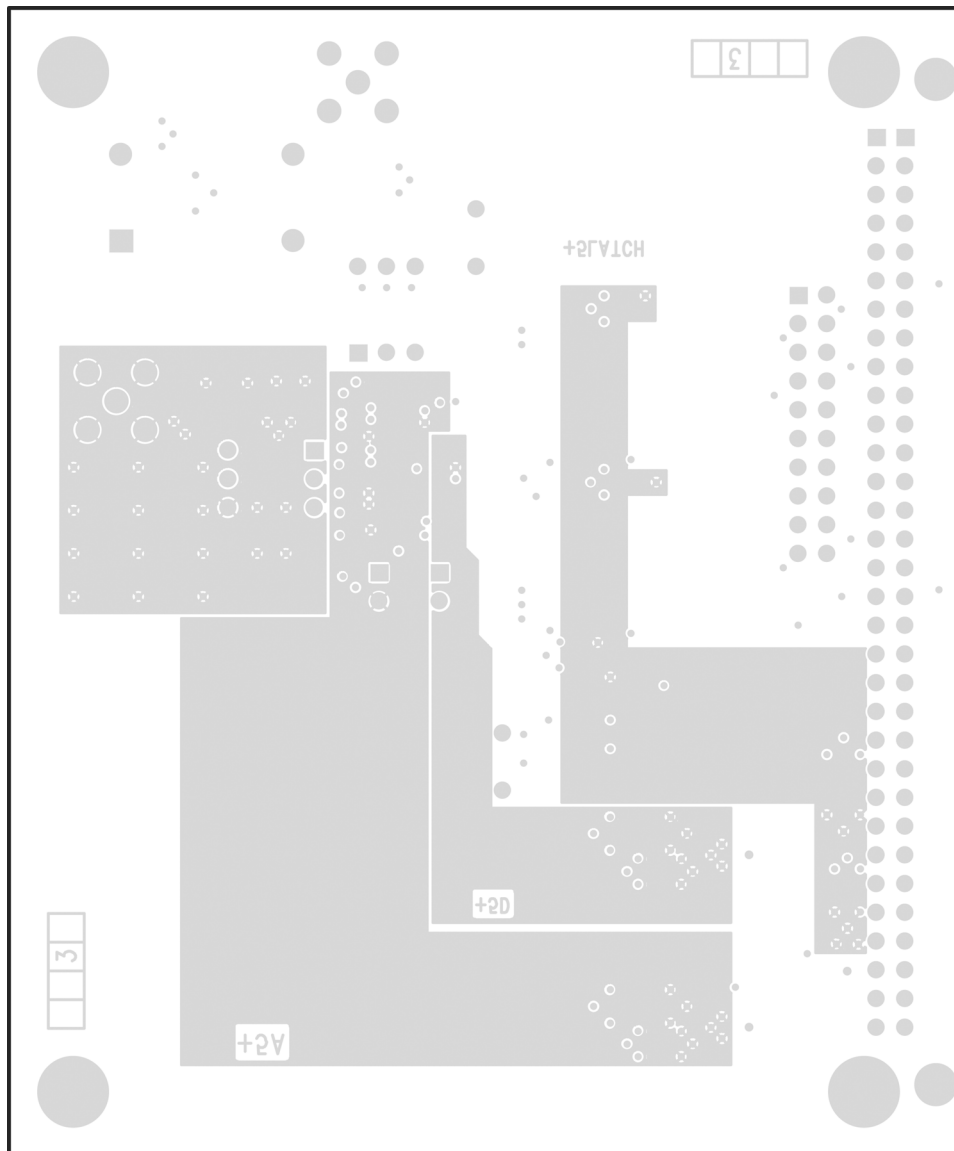

Figure 25. CLC5957PCASM Layer 3

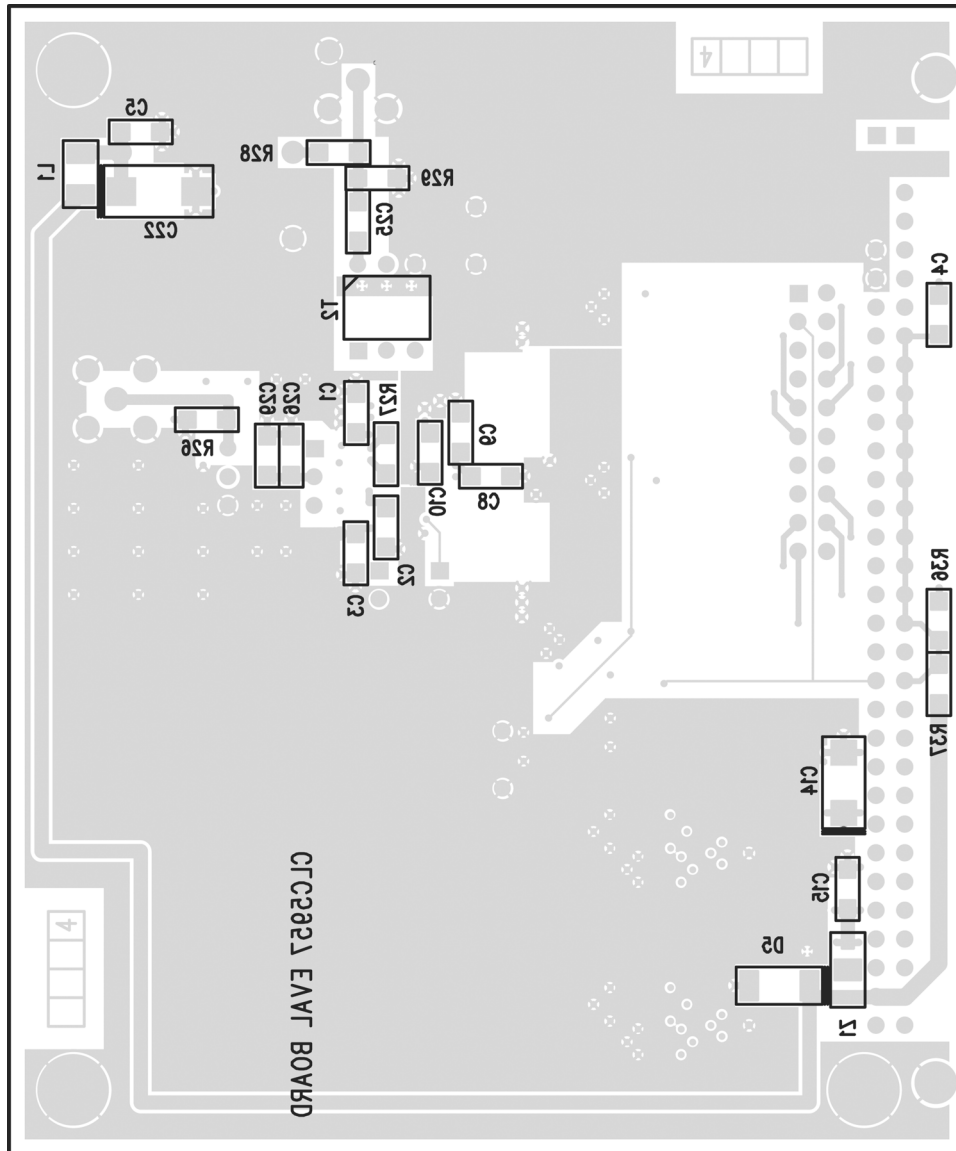

Figure 26. CLC5957PCASM Layer 4

CLC5957 Applications

Analog Inputs and Bias

Figure 27 depicts the analog input and bias scheme. Each of the differential analog inputs are internally biased to a nominal voltage of 2.40V DC through a 500Ω resistor to a low impedance buffer. This enables a simple interface to a broadband RF transformer with a center-tapped output winding that is decoupled to the analog ground. If the application requires the inputs to be DC coupled, the V_{CM} output can be used to establish the proper common-mode input voltage for the ADC. The V_{CM} voltage reference is generated from an internal bandgap source that is very accurate and stable.

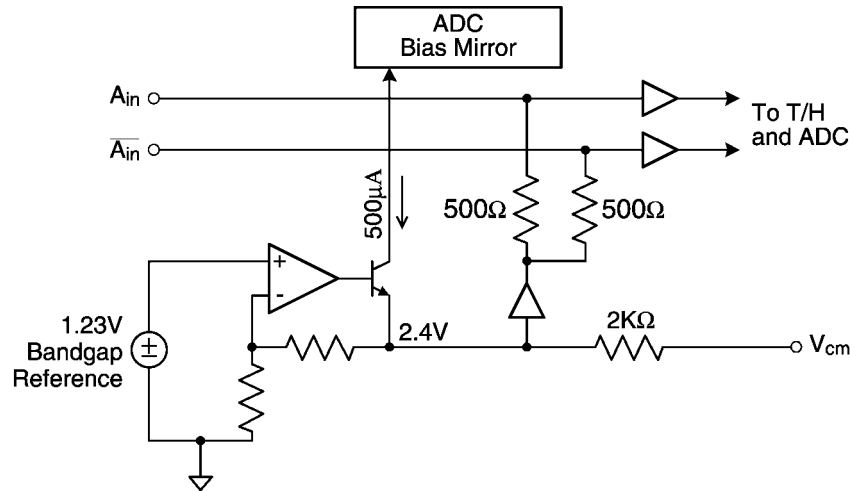

Figure 27. CLC5957 Bias Scheme

The V_{CM} output may also be used to power down the ADC. When the V_{CM} pin is pulled above 3.5V, the internal bias mirror is disabled and the total current is reduced to less than 10mA. Figure 28 depicts how this function can be used. The diode is necessary to prevent the logic gate from altering the ADC bias value.

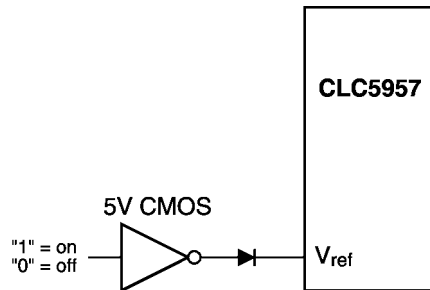

Figure 28. Power Shutdown Scheme

ENCODE Clock Inputs

The CLC5957's differential input clock scheme is compatible with all commonly used clock sources. Although small differential and single-ended signals are adequate, for best aperture jitter performance a low noise differential clock with a high slew rate is preferred. As depicted in Figure 29, both ENCODE clock inputs are internally biased to $V_{CC}/2$ through a pair of 5kΩ resistors. The clock input buffer operates with any common-mode voltage between the supply and ground.

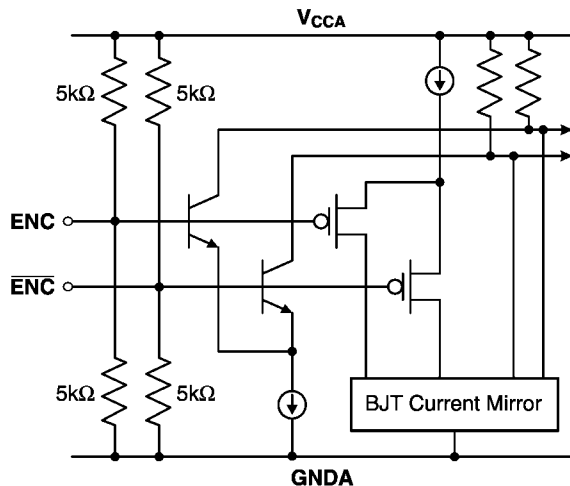

Figure 29. CLC5957 ENCODE Clock Inputs

The internal bias resistors simplify the clock interface to another center-tapped transformer as depicted in Figure 30. A low phase noise, RF synthesizer of moderate amplitude ($1 - 4V_{PP}$) can drive the ADC through this interface.

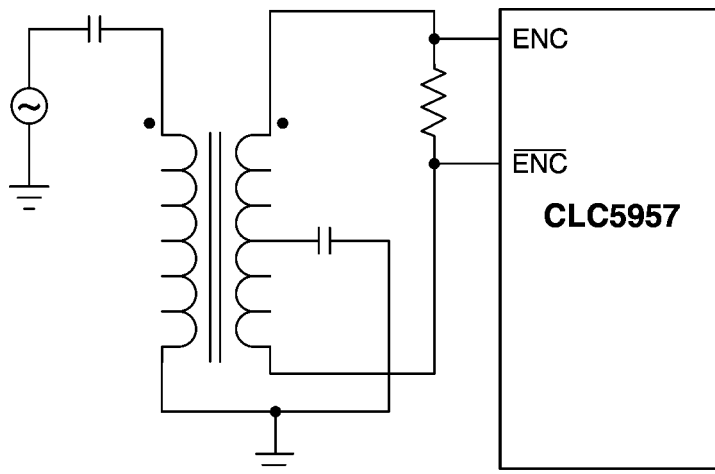

Figure 30. Transformer Coupled Clock Scheme

Figure 31 shows the clock interface scheme for square wave clock sources.

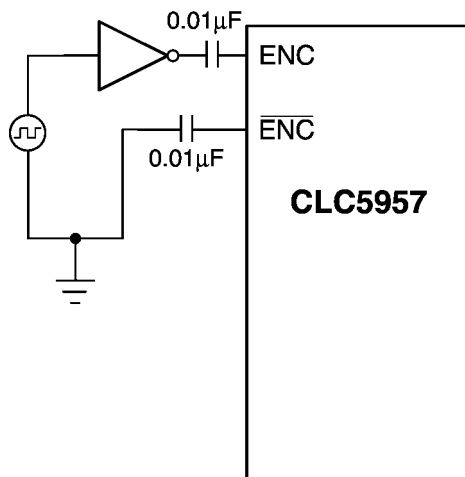

Figure 31. TTL, 3V CMOS or 5V CMOS Clock Scheme

Digital Outputs and Level Select

Figure 32 depicts the digital output buffer and bias used in the CLC5957. Although each of the twelve output bits uses a controlled current buffer to limit supply transients, it is recommended that parasitic loading of the outputs is minimized. Because these output transients are harmonically related to the analog input signal, excessive loading will degrade ADC performance at some frequencies.

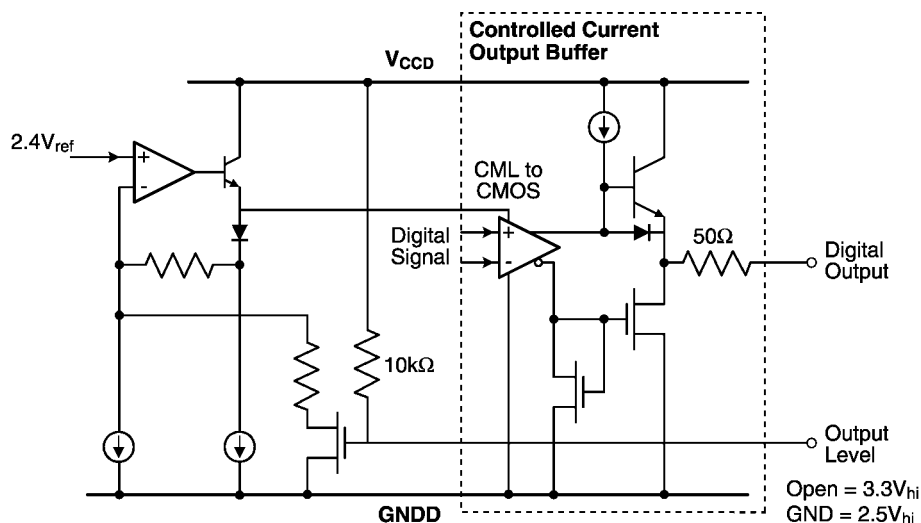

Figure 32. CLC5957 Digital Outputs

The logic high level is slaved to the internal 2.4V reference. The OUTLEV control pin selects either a 3.3V or 2.5V logic high level. An internal pull up resistor selects the 3.3V level as the default when the OUTLEV pin is left open. Grounding the OUTLEV pin selects the 2.5V logic high level.

To ease user interface to subsequent digital circuitry, the CLC5957 has a data valid clock output (DAV). In order to match delays over IC processing variables, this digital output also uses the same output buffer as the data bits. The DAV clock output is simply a delayed version of the ENCODE input clock. Since the ADC output data change is slaved to the falling edge of the ENCODE clock, the rising DAV clock edge occurs near the center of the data valid window (or eye) regardless of the sampling frequency.

Minimum Conversion Rate

This ADC is optimized for high-speed operation. The internal bipolar track and hold circuits will cause droop errors at low sample rates. The point at which these errors cause a degradation of performance is listed on the specification page as the minimum conversion rate. If a lower sample rate is desired, the ADC should be clocked at a higher rate, and the output data should be decimated. For example, to obtain a 10MSPS output, the ADC should be clocked at 20MHZ, and every other output sample should be used. No significant power savings occurs at lower sample rates, since most of the power is used in analog circuits rather than digital circuits.

CLC5957 Evaluation Board

Description

The Evaluation board for the CLC5957 allows for easy test and evaluation of the product. The part may be ordered with all components loaded and tested. The order number is the CLC5957PCASM. The user supplies an analog input signal, encode signal and power to the board and is able to take latched 12-bit digital data out of the board.

ENCODE Input (ENC)

The ENCODE input is an SMA connector with a termination of 50Ω. The encode signal is converted to an AC coupled, differential clock signal centered between V_{CC} and ground. The user should supply a sinusoidal or square wave signal of $> 200mV_{PP}$ and $< 4 V_{PP}$ with a 50% duty cycle. The duty cycle can vary from 50% if the minimum clock pulse width times are observed. A low jitter source will be required for IF-sampled analog input signals to maintain best performance.

CLC5957 Clock Option

The CLC5957 evaluation board is configured for use with an optional crystal clock oscillator source. The component Y1 may be loaded with a "Full-sized", HCMOS type, crystal oscillator.

Analog Input (AIN)

The analog input is an SMA connector with a 50Ω termination. The signal is converted from single to differential by a transformer with a 5 to 260MHz bandwidth and approximately one dB loss. Full scale is approximately 11dBm or 2.2V_{PP}. It is recommended that the source for the analog input signal be low jitter, low noise and low distortion to allow for proper test and evaluation of the CLC5957.

Supply voltages (J1 pins 31 A&B and 32 A&B)

The CLC5957PCASM is powered from a single 5V supply connected from the referenced pins on the Eurocard connector. The recommended supplies are low noise linear supplies.

Digital Outputs (J1 pins 7B (\overline{MSB} , $\overline{D11}$) through 18B (LSB) and 20B (Data Valid))

The digital outputs are provided on the Eurocard connector. The outputs are buffered by 5V CMOS latches with 50Ω series output resistors. The rising edge of Data Valid may be used to clock the output data into data collection cards or logic analyzers. The board has a location for the HP 01650-63203 termination adapter for HP 16500 logic analyzers to simplify connection to the analyzer.

REVISION HISTORY

Changes from Revision B (April 2013) to Revision C	Page
• Changed layout of National Data Sheet to TI format	19

IMPORTANT NOTICE

Texas Instruments Incorporated and its subsidiaries (TI) reserve the right to make corrections, enhancements, improvements and other changes to its semiconductor products and services per JESD46, latest issue, and to discontinue any product or service per JESD48, latest issue. Buyers should obtain the latest relevant information before placing orders and should verify that such information is current and complete. All semiconductor products (also referred to herein as "components") are sold subject to TI's terms and conditions of sale supplied at the time of order acknowledgment.

TI warrants performance of its components to the specifications applicable at the time of sale, in accordance with the warranty in TI's terms and conditions of sale of semiconductor products. Testing and other quality control techniques are used to the extent TI deems necessary to support this warranty. Except where mandated by applicable law, testing of all parameters of each component is not necessarily performed.

TI assumes no liability for applications assistance or the design of Buyers' products. Buyers are responsible for their products and applications using TI components. To minimize the risks associated with Buyers' products and applications, Buyers should provide adequate design and operating safeguards.

TI does not warrant or represent that any license, either express or implied, is granted under any patent right, copyright, mask work right, or other intellectual property right relating to any combination, machine, or process in which TI components or services are used. Information published by TI regarding third-party products or services does not constitute a license to use such products or services or a warranty or endorsement thereof. Use of such information may require a license from a third party under the patents or other intellectual property of the third party, or a license from TI under the patents or other intellectual property of TI.

Reproduction of significant portions of TI information in TI data books or data sheets is permissible only if reproduction is without alteration and is accompanied by all associated warranties, conditions, limitations, and notices. TI is not responsible or liable for such altered documentation. Information of third parties may be subject to additional restrictions.

Resale of TI components or services with statements different from or beyond the parameters stated by TI for that component or service voids all express and any implied warranties for the associated TI component or service and is an unfair and deceptive business practice. TI is not responsible or liable for any such statements.

Buyer acknowledges and agrees that it is solely responsible for compliance with all legal, regulatory and safety-related requirements concerning its products, and any use of TI components in its applications, notwithstanding any applications-related information or support that may be provided by TI. Buyer represents and agrees that it has all the necessary expertise to create and implement safeguards which anticipate dangerous consequences of failures, monitor failures and their consequences, lessen the likelihood of failures that might cause harm and take appropriate remedial actions. Buyer will fully indemnify TI and its representatives against any damages arising out of the use of any TI components in safety-critical applications.

In some cases, TI components may be promoted specifically to facilitate safety-related applications. With such components, TI's goal is to help enable customers to design and create their own end-product solutions that meet applicable functional safety standards and requirements. Nonetheless, such components are subject to these terms.

No TI components are authorized for use in FDA Class III (or similar life-critical medical equipment) unless authorized officers of the parties have executed a special agreement specifically governing such use.

Only those TI components which TI has specifically designated as military grade or "enhanced plastic" are designed and intended for use in military/aerospace applications or environments. Buyer acknowledges and agrees that any military or aerospace use of TI components which have **not** been so designated is solely at the Buyer's risk, and that Buyer is solely responsible for compliance with all legal and regulatory requirements in connection with such use.

TI has specifically designated certain components as meeting ISO/TS16949 requirements, mainly for automotive use. In any case of use of non-designated products, TI will not be responsible for any failure to meet ISO/TS16949.

Products

Audio	www.ti.com/audio
Amplifiers	amplifier.ti.com
Data Converters	dataconverter.ti.com
DLP® Products	www.dlp.com
DSP	dsp.ti.com
Clocks and Timers	www.ti.com/clocks
Interface	interface.ti.com
Logic	logic.ti.com
Power Mgmt	power.ti.com
Microcontrollers	microcontroller.ti.com
RFID	www.ti-rfid.com
OMAP Applications Processors	www.ti.com/omap
Wireless Connectivity	www.ti.com/wirelessconnectivity

Applications

Automotive and Transportation	www.ti.com/automotive
Communications and Telecom	www.ti.com/communications
Computers and Peripherals	www.ti.com/computers
Consumer Electronics	www.ti.com/consumer-apps
Energy and Lighting	www.ti.com/energy
Industrial	www.ti.com/industrial
Medical	www.ti.com/medical
Security	www.ti.com/security
Space, Avionics and Defense	www.ti.com/space-avionics-defense
Video and Imaging	www.ti.com/video

TI E2E Community

e2e.ti.com

Looking for pricing, stock, or lifecycle information?

Click below to explore more details on WIN SOURCE:

- ⊖ [View CLC5957MTDX/NOPB on WIN SOURCE](#)
- ⊖ [Texas Instruments Information](#)

Optimize Your Supply Chain with WIN SOURCE Solutions

- ✓ Global Sourcing Solution
- ✓ Obsolete Management
- ✓ Cost Control Management
- ✓ Shortage Management
- ✓ Alternative Solution
- ✓ Excess Inventory Management