



**THE DATASHEET OF  
CD74HC191MT**



# CD54HC190, CD74HC190 CD54HC191, CD74HC191, CD54HCT191, CD74HCT191 SYNCHRONOUS UP/DOWN COUNTERS WITH DOWN/UP MODE CONTROL

SCHS275E – MARCH 2002 – REVISED OCTOBER 2003

- 2-V to 6-V  $V_{CC}$  Operation ('HC190, 191)
- 4.5-V to 5.5-V  $V_{CC}$  Operation ('HCT191)
- Wide Operating Temperature Range of  $-55^{\circ}\text{C}$  to  $125^{\circ}\text{C}$
- Synchronous Counting and Asynchronous Loading
- Two Outputs for n-Bit Cascading
- Look-Ahead Carry for High-Speed Counting
- Balanced Propagation Delays and Transition Times
- Standard Outputs Drive Up To 15 LS-TTL Loads
- Significant Power Reduction Compared to LS-TTL Logic ICs

CD54HC190, 191; CD54HCT191 . . . F PACKAGE  
CD74HC190 . . . E, NS, OR PW PACKAGE  
CD74HC191, CD74HCT191 . . . E OR M PACKAGE  
(TOP VIEW)

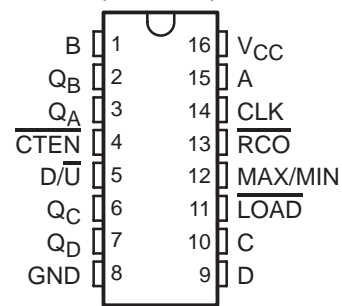

## description/ordering information

The CD54/74HC190 are asynchronously presettable BCD decade counters, whereas the CD54/74HC191 and CD54/74HCT191 are asynchronously presettable binary counters.

Presetting the counter to the number on preset data inputs (A–D) is accomplished by a low asynchronous parallel load (LOAD) input. Counting occurs when LOAD is high, count enable (CTEN) is low, and the down/up (D/U) input is either high for down counting or low for up counting. The counter is decremented or incremented synchronously with the low-to-high transition of the clock.

## ORDERING INFORMATION

$T_A$	PACKAGE†		ORDERABLE PART NUMBER	TOP-SIDE MARKING	
$-55^{\circ}\text{C}$ to $125^{\circ}\text{C}$	PDIP – E	Tube of 25	CD74HC190E	CD74HC190E	
			CD74HC191E	CD74HC191E	
			CD74HCT191E	CD74HCT191E	
	SOIC – M	Tube of 40	CD74HC191M	HC191M	
			Reel of 2500		CD74HC191M96
			Reel of 250		CD74HC191MT
		Tube of 40	CD74HCT191M	HCT191M	
	SOP – NS	Reel of 2000	CD74HC190NSR	HC190M	
	TSSOP – PW	Tube of 90	CD74HC190PW	HJ190	
		Reel of 2000	CD74HC190PWR		
		Reel of 250	CD74HC190PWT		
	CDIP – F	Tube of 25	CD54HC190F3A	CD54HC190F3A	
			CD54HC191F3A	CD54HC191F3A	
CD54HCT191F3A			CD54HCT191F3A		

† Package drawings, standard packing quantities, thermal data, symbolization, and PCB design guidelines are available at [www.ti.com/sc/package](http://www.ti.com/sc/package).



Please be aware that an important notice concerning availability, standard warranty, and use in critical applications of Texas Instruments semiconductor products and disclaimers thereto appears at the end of this data sheet.

PRODUCTION DATA information is current as of publication date. Products conform to specifications per the terms of Texas Instruments standard warranty. Production processing does not necessarily include testing of all parameters.

**TEXAS  
INSTRUMENTS**

POST OFFICE BOX 655303 • DALLAS, TEXAS 75265

Copyright © 2003, Texas Instruments Incorporated  
On products compliant to MIL-PRF-38535, all parameters are tested unless otherwise noted. On all other products, production processing does not necessarily include testing of all parameters.

**CD54HC190, CD74HC190**  
**CD54HC191, CD74HC191, CD54HCT191, CD74HCT191**  
**SYNCHRONOUS UP/DOWN COUNTERS WITH DOWN/UP MODE CONTROL**



SCHS275E – MARCH 2002 – REVISED OCTOBER 2003

**description/ordering information (continued)**

When an overflow or underflow of the counter occurs, the MAX/MIN output, which is low during counting, goes high and remains high for one clock cycle. This output can be used for look-ahead carry in high-speed cascading (see Figure 1). The MAX/MIN output also initiates the ripple clock ( $\overline{RCO}$ ) output, which normally is high, goes low, and remains low for the low-level portion of the clock pulse. These counters can be cascaded using  $\overline{RCO}$  (see Figure 2).

If a decade counter is preset to an illegal state or assumes an illegal state when power is applied, it returns to the normal sequence in one or two counts, as shown in the state diagrams (see Figure 3).

**FUNCTION TABLE**

INPUTS				FUNCTION
$\overline{LOAD}$	$\overline{CTEN}$	$D/\overline{U}$	CLK	
H	L	L		Count up
H	L	H		Count down
L	X	X	X	Asynchronous preset
H	H	X	X	No change

$\overline{D/\overline{U}}$  or  $\overline{CTEN}$  should be changed only when clock is high.

X = Don't care

 Low-to-high clock transition

**CD54HC190, CD74HC190**  
**CD54HC191, CD74HC191, CD54HCT191, CD74HCT191**  
**SYNCHRONOUS UP/DOWN COUNTERS WITH DOWN/UP MODE CONTROL**

SCHS275E – MARCH 2002 – REVISED OCTOBER 2003

'HC190 logic diagram

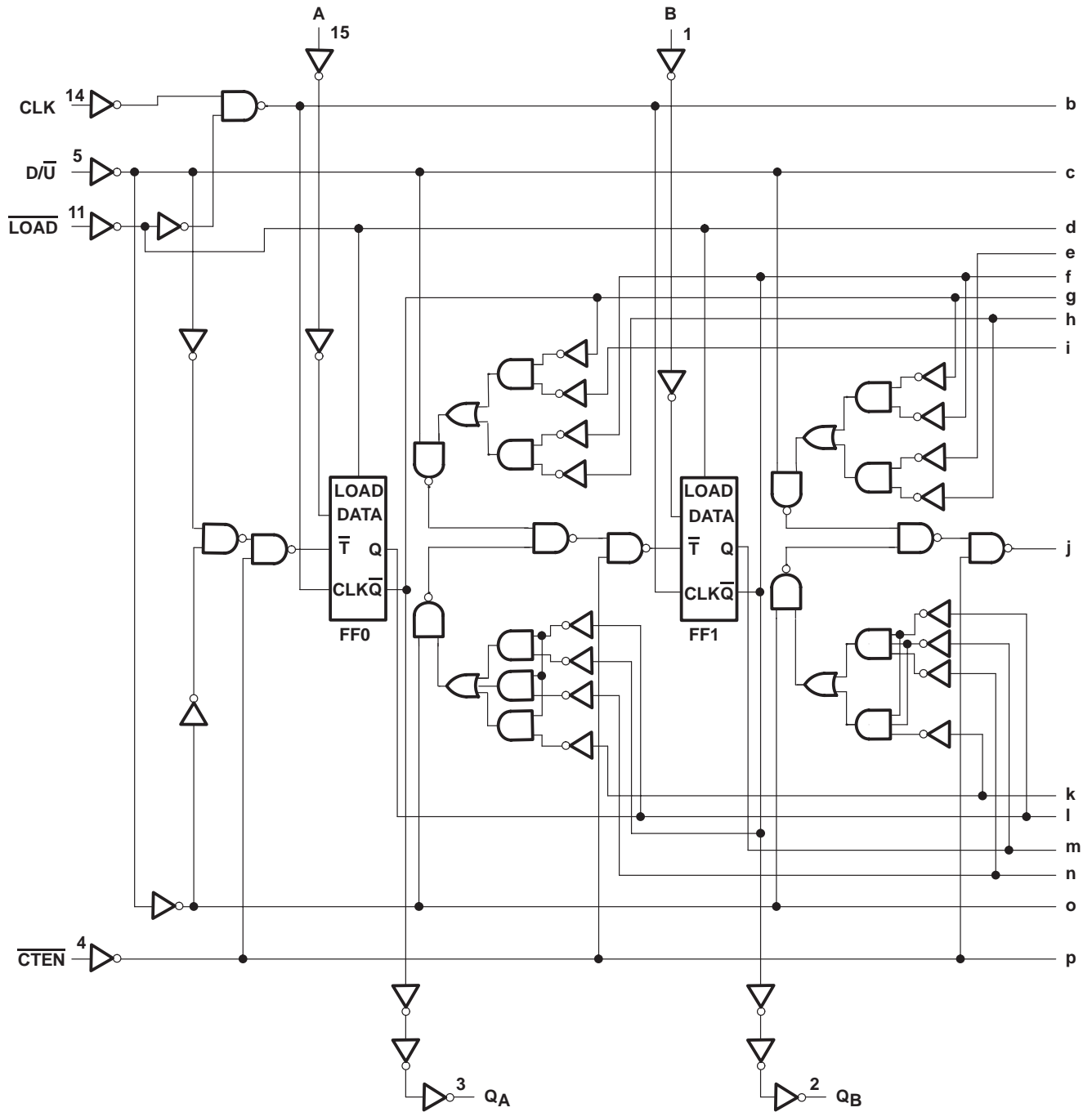

**CD54HC190, CD74HC190**  
**CD54HC191, CD74HC191, CD54HCT191, CD74HCT191**  
**SYNCHRONOUS UP/DOWN COUNTERS WITH DOWN/UP MODE CONTROL**

SCHS275E – MARCH 2002 – REVISED OCTOBER 2003

'HC190 logic diagram (continued)

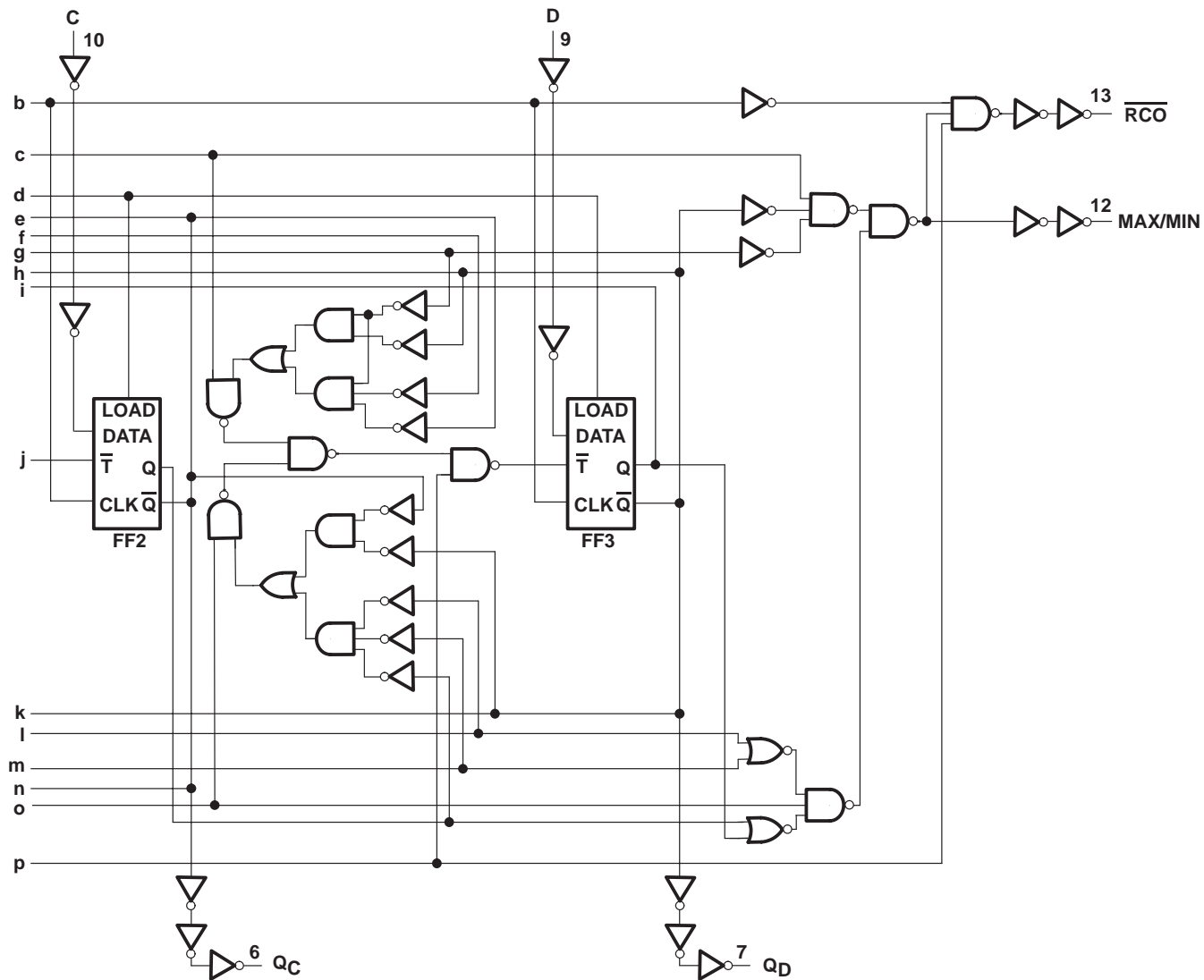

**CD54HC190, CD74HC190**  
**CD54HC191, CD74HC191, CD54HCT191, CD74HCT191**  
**SYNCHRONOUS UP/DOWN COUNTERS WITH DOWN/UP MODE CONTROL**

SCHS275E – MARCH 2002 – REVISED OCTOBER 2003

'HC191, 'HCT191 logic diagram

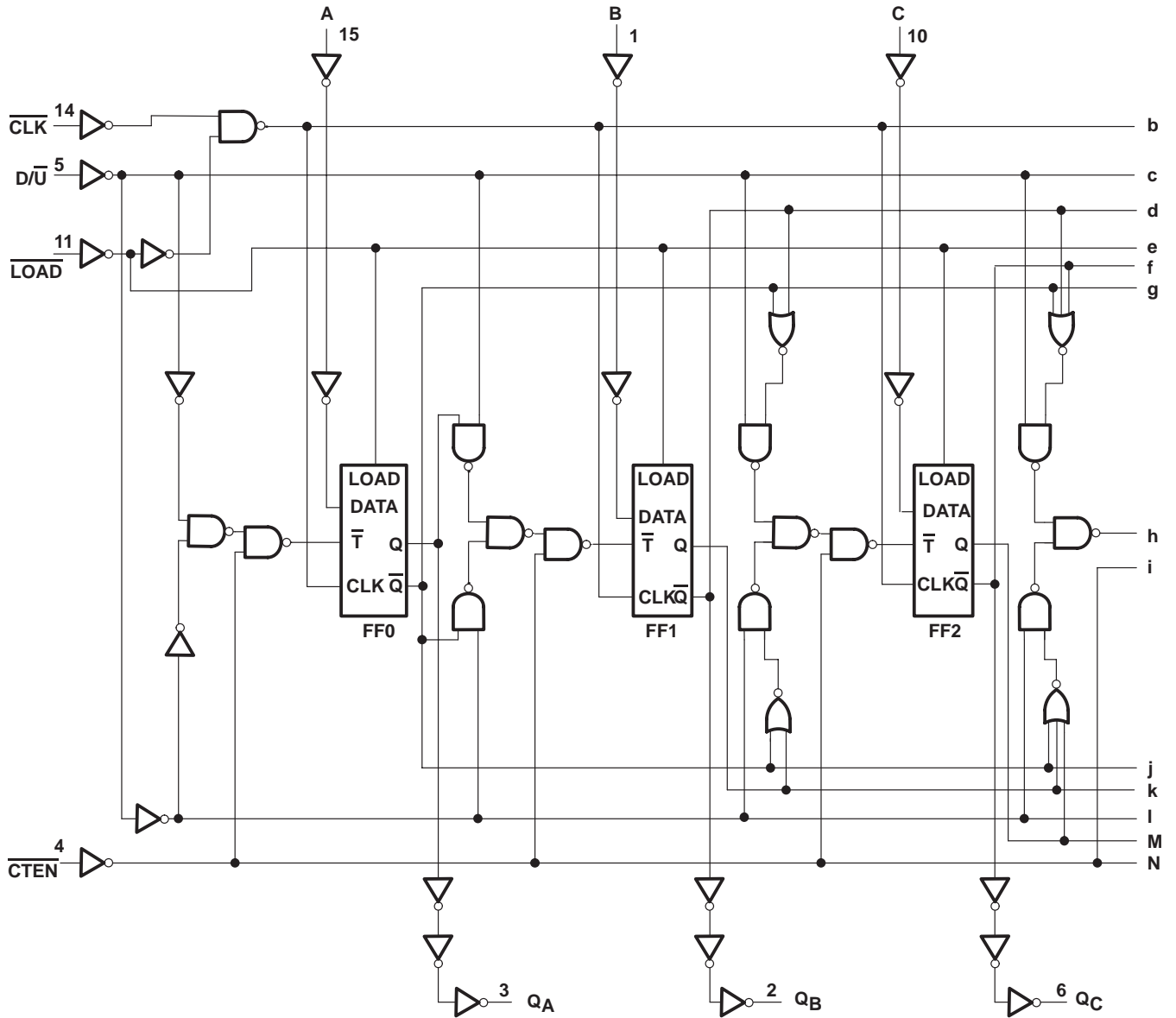

**CD54HC190, CD74HC190  
 CD54HC191, CD74HC191, CD54HCT191, CD74HCT191  
 SYNCHRONOUS UP/DOWN COUNTERS WITH DOWN/UP MODE CONTROL**

SCHS275E – MARCH 2002 – REVISED OCTOBER 2003

'HC191, 'HCT191 logic diagram (continued)

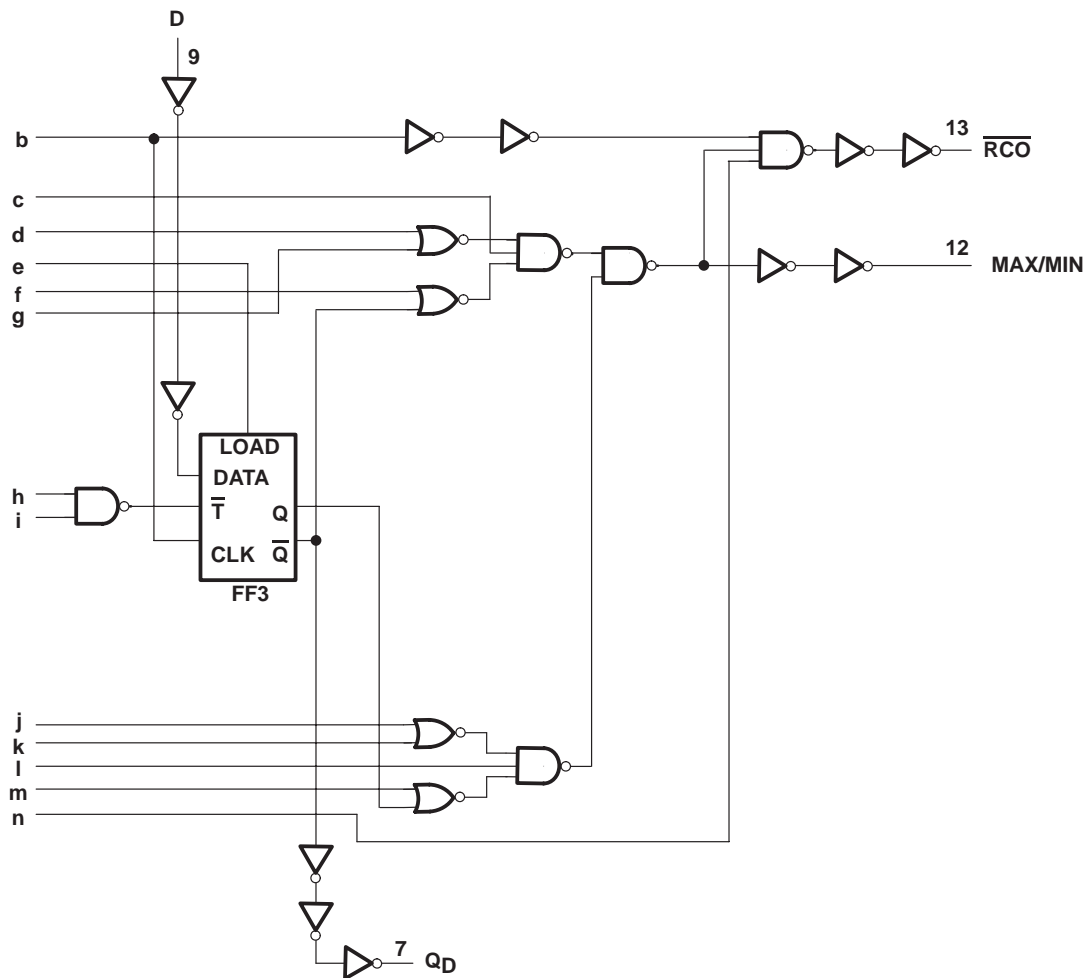



**CD54HC190, CD74HC190**  
**CD54HC191, CD74HC191, CD54HCT191, CD74HCT191**  
**SYNCHRONOUS UP/DOWN COUNTERS WITH DOWN/UP MODE CONTROL**

SCHS275E – MARCH 2002 – REVISED OCTOBER 2003

**typical load, count, and inhibit sequence for 'HC190**

The following sequence is illustrated below:

1. Load (preset) to BCD 7
2. Count up to 8, 9 (maximum), 0, 1, and 2
3. Inhibit
4. Count down to 1, 0 (minimum), 9, 8, and 7

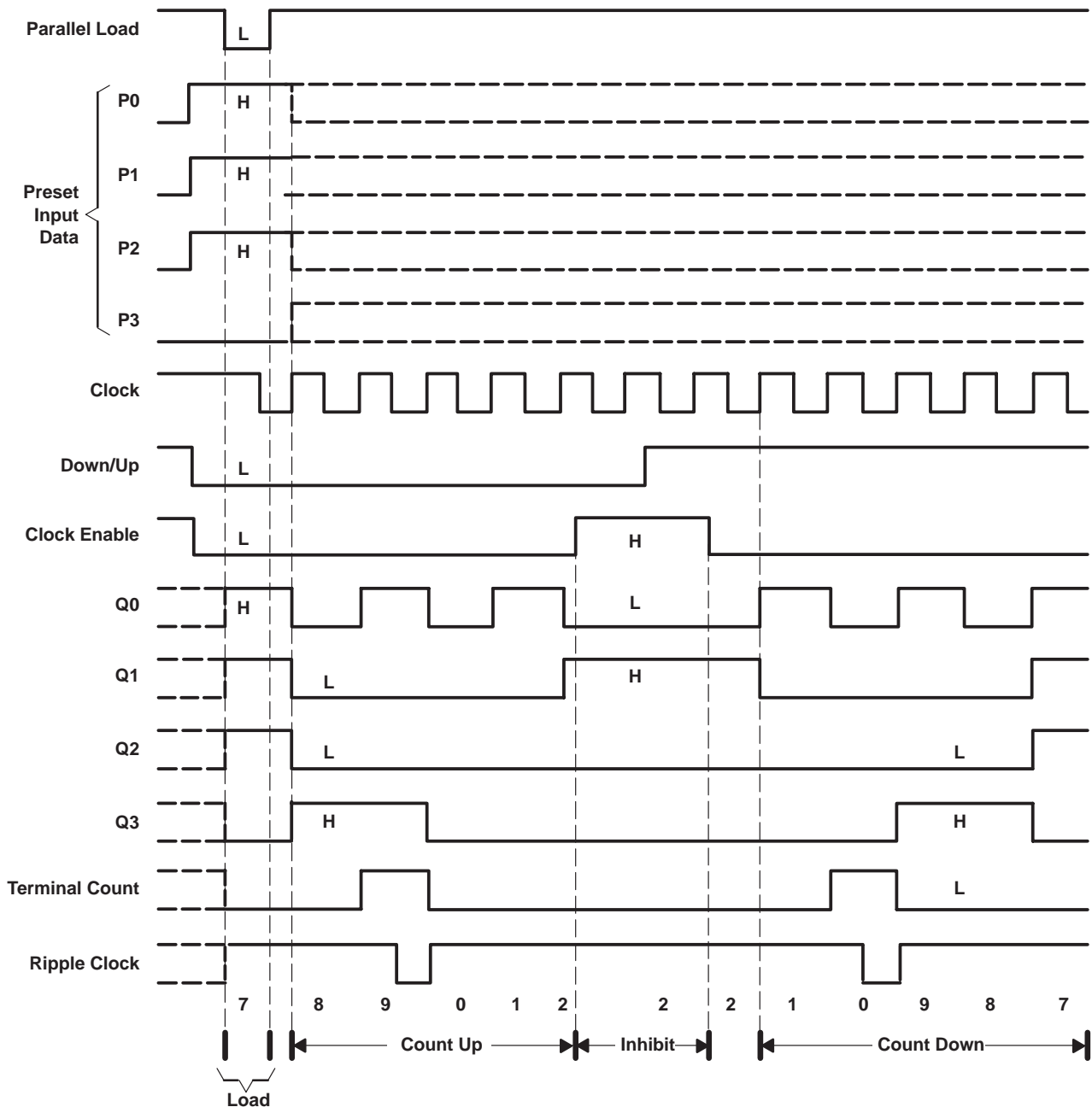

**CD54HC190, CD74HC190**  
**CD54HC191, CD74HC191, CD54HCT191, CD74HCT191**  
**SYNCHRONOUS UP/DOWN COUNTERS WITH DOWN/UP MODE CONTROL**

SCHS275E – MARCH 2002 – REVISED OCTOBER 2003

**typical load, count, and inhibit sequence for 'HC191 and 'HCT191**

The following sequence is illustrated below:

1. Load (preset) to binary 13
2. Count up to 14, 15 (maximum), 0, 1, and 2
3. Inhibit
4. Count down to 1, 0 (minimum), 15, 14, and 13

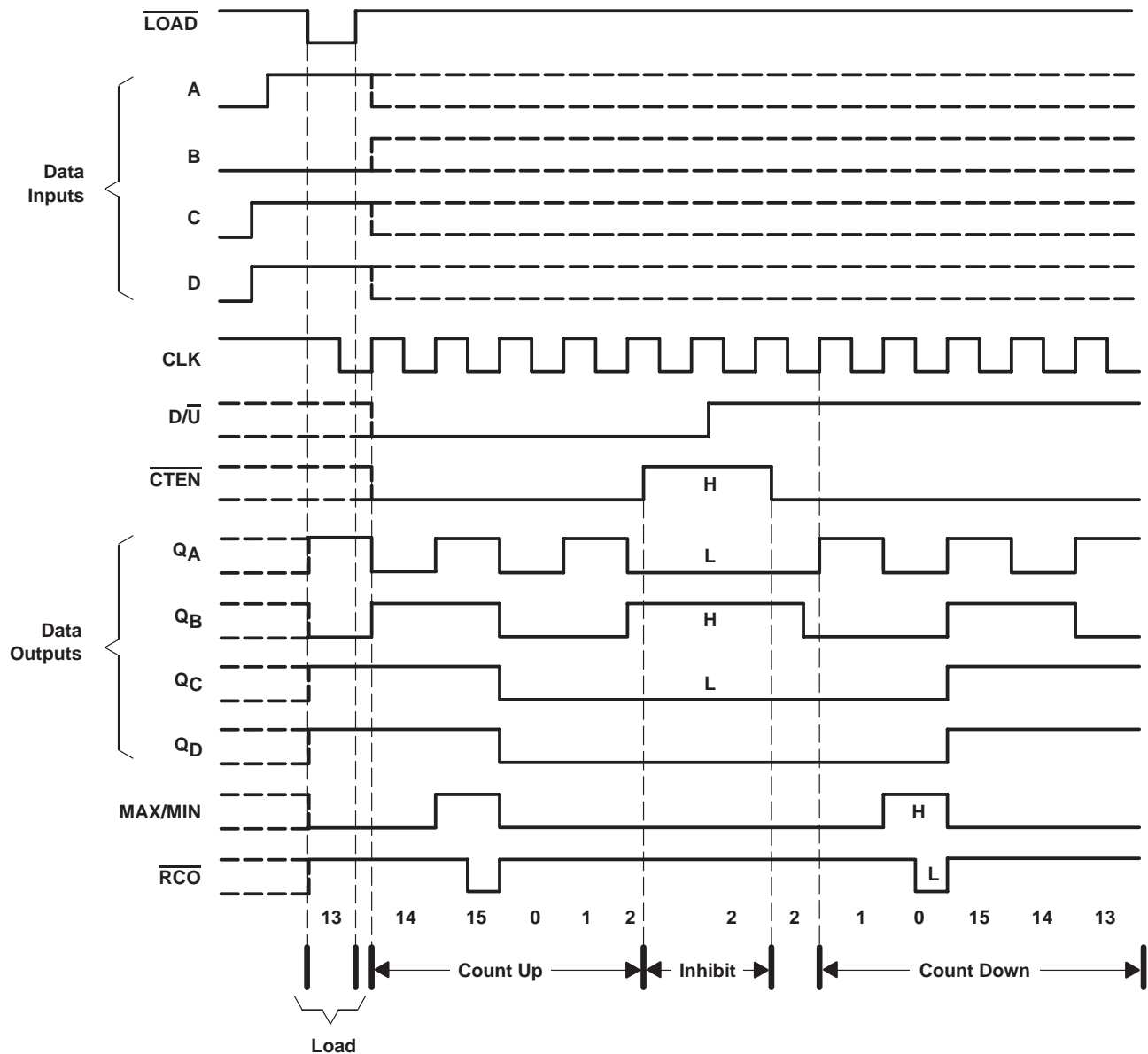

**CD54HC190, CD74HC190**  
**CD54HC191, CD74HC191, CD54HCT191, CD74HCT191**  
**SYNCHRONOUS UP/DOWN COUNTERS WITH DOWN/UP MODE CONTROL**

SCHS275E – MARCH 2002 – REVISED OCTOBER 2003

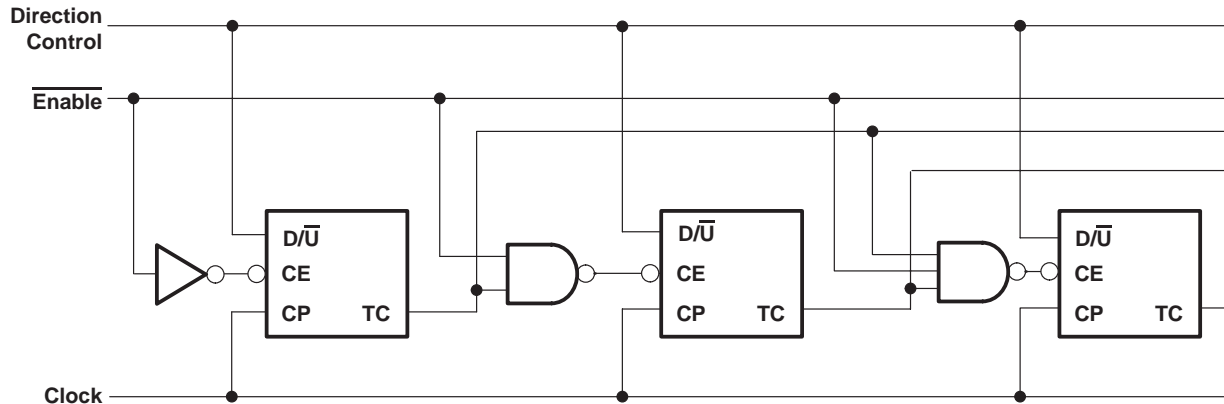

**Figure 1. 'HC190 Synchronous n-Stage Counter With Parallel Gated Terminal Count**

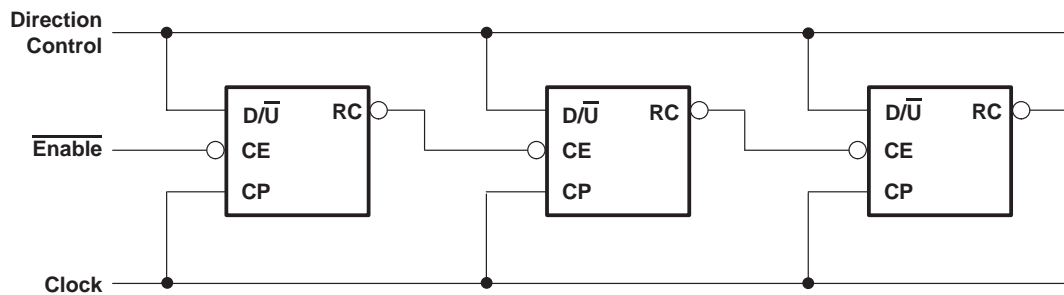

**Figure 2. 'HC191, 'HCT191 Synchronous n-Stage Counter With Parallel Gated Terminal Count**

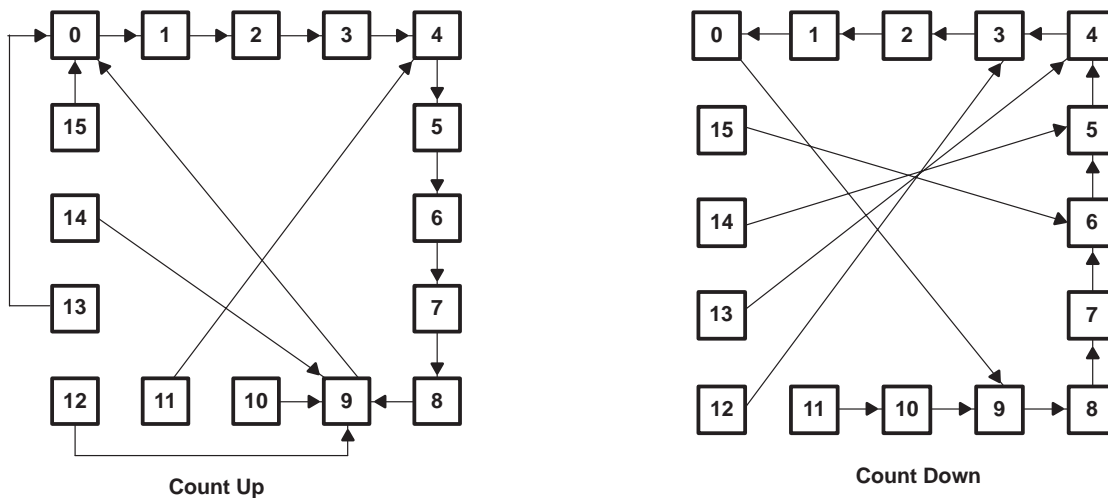

NOTE: Illegal states in BCD counters corrected in one count

NOTE: Illegal states in BCD counters corrected in one or two counts

**Figure 3. 'HC190 State Diagram**

**CD54HC190, CD74HC190**  
**CD54HC191, CD74HC191, CD54HCT191, CD74HCT191**  
**SYNCHRONOUS UP/DOWN COUNTERS WITH DOWN/UP MODE CONTROL**

SCHS275E – MARCH 2002 – REVISED OCTOBER 2003

**absolute maximum ratings over operating free-air temperature range (unless otherwise noted)†**

Supply voltage range, $V_{CC}$ .....	–0.5 V to 7 V
Input clamp current, $I_{IK}$ ( $V_I < 0$ or $V_I > V_{CC}$ ) (see Note 1) .....	±20 mA
Output clamp current, $I_{OK}$ ( $V_O < 0$ or $V_O > V_{CC}$ ) (see Note 1) .....	±20 mA
Continuous output drain current per output, $I_O$ ( $V_O = 0$ to $V_{CC}$ ) .....	±35 mA
Continuous output source or sink current per output, $I_O$ ( $V_O = 0$ to $V_{CC}$ ) .....	±25 mA
Continuous current through $V_{CC}$ or GND .....	±50 mA
Package thermal impedance, $\theta_{JA}$ (see Note 2): E package .....	67°C/W
M package .....	73°C/W
NS package .....	64°C/W
PW package .....	108°C/W
Storage temperature range, $T_{stg}$ .....	–65°C to 150°C

† Stresses beyond those listed under “absolute maximum ratings” may cause permanent damage to the device. These are stress ratings only, and functional operation of the device at these or any other conditions beyond those indicated under “recommended operating conditions” is not implied. Exposure to absolute-maximum-rated conditions for extended periods may affect device reliability.

- NOTES: 1. The input and output voltage ratings may be exceeded if the input and output current ratings are observed.  
 2. The package thermal impedance is calculated in accordance with JESD 51-7.

**recommended operating conditions for 'HC190 and 'HC191 (see Note 3)**

		$T_A = 25^\circ\text{C}$		$T_A = -55^\circ\text{C}$ TO $125^\circ\text{C}$		$T_A = -40^\circ\text{C}$ TO $85^\circ\text{C}$		UNIT
		MIN	MAX	MIN	MAX	MIN	MAX	
$V_{CC}$	Supply voltage	2	6	2	6	2	6	V
$V_{IH}$	High-level input voltage	$V_{CC} = 2\text{ V}$		1.5	1.5	1.5		V
		$V_{CC} = 4.5\text{ V}$		3.15	3.15	3.15		
		$V_{CC} = 6\text{ V}$		4.2	4.2	4.2		
$V_{IL}$	Low-level input voltage	$V_{CC} = 2\text{ V}$		0.5		0.5		V
		$V_{CC} = 4.5\text{ V}$		1.35		1.35		
		$V_{CC} = 6\text{ V}$		1.8		1.8		
$V_I$	Input voltage	0	$V_{CC}$	0	$V_{CC}$	0	$V_{CC}$	V
$V_O$	Output voltage	0	$V_{CC}$	0	$V_{CC}$	0	$V_{CC}$	V
$t_t$	Input transition (rise and fall) time	$V_{CC} = 2\text{ V}$		1000		1000		ns
		$V_{CC} = 4.5\text{ V}$		500		500		
		$V_{CC} = 6\text{ V}$		400		400		

NOTE 3: All unused inputs of the device must be held at  $V_{CC}$  or GND to ensure proper device operation. Refer to the TI application report, *Implications of Slow or Floating CMOS Inputs*, literature number SCBA004.

**recommended operating conditions for 'HCT191 (see Note 4)**

		$T_A = 25^\circ\text{C}$		$T_A = -55^\circ\text{C}$ TO $125^\circ\text{C}$		$T_A = -40^\circ\text{C}$ TO $85^\circ\text{C}$		UNIT
		MIN	MAX	MIN	MAX	MIN	MAX	
$V_{CC}$	Supply voltage	4.5	5.5	4.5	5.5	4.5	5.5	V
$V_{IH}$	High-level input voltage	2		2		2		V
$V_{IL}$	Low-level input voltage	0.8		0.8		0.8		V
$V_I$	Input voltage	$V_{CC}$		$V_{CC}$		$V_{CC}$		V
$V_O$	Output voltage	$V_{CC}$		$V_{CC}$		$V_{CC}$		V
$t_t$	Input transition (rise and fall) time	500		500		500		ns

NOTE 4: All unused inputs of the device must be held at  $V_{CC}$  or GND to ensure proper device operation. Refer to the TI application report, *Implications of Slow or Floating CMOS Inputs*, literature number SCBA004.



**CD54HC190, CD74HC190**  
**CD54HC191, CD74HC191, CD54HCT191, CD74HCT191**  
**SYNCHRONOUS UP/DOWN COUNTERS WITH DOWN/UP MODE CONTROL**

SCHS275E – MARCH 2002 – REVISED OCTOBER 2003

**'HC190, 'HC191**

**electrical characteristics over recommended operating free-air temperature range (unless otherwise noted)**

PARAMETER	TEST CONDITIONS		V <sub>CC</sub>	T <sub>A</sub> = 25°C		T <sub>A</sub> = -55°C TO 125°C		T <sub>A</sub> = -40°C TO 85°C		UNIT
				MIN	MAX	MIN	MAX	MIN	MAX	
V <sub>OH</sub>	V <sub>I</sub> = V <sub>IH</sub> or V <sub>IL</sub>	I <sub>OH</sub> = -20 μA	2 V	1.9	1.9	1.9			V	
			4.5 V	4.4	4.4	4.4				
			6 V	5.9	5.9	5.9				
		I <sub>OH</sub> = -4 mA	4.5 V	3.98	3.7	3.84				
		I <sub>OH</sub> = -5.2 mA	6 V	5.48	5.2	5.34				
V <sub>OL</sub>	V <sub>I</sub> = V <sub>IH</sub> or V <sub>IL</sub>	I <sub>OL</sub> = 20 μA	2 V	0.1	0.1	0.1			V	
			4.5 V	0.1	0.1	0.1				
			6 V	0.1	0.1	0.1				
		I <sub>OL</sub> = 4 mA	4.5 V	0.26	0.4	0.33				
		I <sub>OL</sub> = 5.2 mA	6 V	0.26	0.4	0.33				
I <sub>I</sub>	V <sub>I</sub> = V <sub>CC</sub> or 0		6 V	±0.1		±1		±1		μA
I <sub>CC</sub>	V <sub>I</sub> = V <sub>CC</sub> or 0, I <sub>O</sub> = 0		6 V	8		160		80		μA
C <sub>i</sub>				10		10		10		pF

**'HCT191**

**electrical characteristics over recommended operating free-air temperature range (unless otherwise noted)**

PARAMETER	TEST CONDITIONS		V <sub>CC</sub>	T <sub>A</sub> = 25°C			T <sub>A</sub> = -55°C TO 125°C		T <sub>A</sub> = -40°C TO 85°C		UNIT	
				MIN	TYP	MAX	MIN	MAX	MIN	MAX		
V <sub>OH</sub>	V <sub>I</sub> = V <sub>IH</sub> or V <sub>IL</sub>	I <sub>OH</sub> = -20 μA	4.5 V	4.4			4.4		4.4	V		
		I <sub>OH</sub> = -4 mA		3.98			3.7		3.84			
V <sub>OL</sub>	V <sub>I</sub> = V <sub>IH</sub> or V <sub>IL</sub>	I <sub>OL</sub> = 20 μA	4.5 V				0.1		0.1	V		
		I <sub>OL</sub> = 4 mA					0.26		0.4		0.33	
I <sub>I</sub>	V <sub>I</sub> = V <sub>CC</sub> to GND		5.5 V				±0.1		±1		μA	
I <sub>CC</sub>	V <sub>I</sub> = V <sub>CC</sub> or 0, I <sub>O</sub> = 0		5.5 V				8		160		80	μA
ΔI <sub>CC</sub> †	One input at V <sub>CC</sub> - 2.1 V, Other inputs at 0 or V <sub>CC</sub>		4.5 V to 5.5 V		100	360		490		450		μA
C <sub>i</sub>							10		10		10	pF

† Additional quiescent supply current per input pin, TTL inputs high, 1 unit load

**HCT INPUT LOADING TABLE**

INPUTS	UNIT LOADS
A-D	0.4
CLK	1.5
LOAD	1.5
D/ <u>U</u>	1.2
<u>CTEN</u>	1.5

Unit load is ΔI<sub>CC</sub> limit specified in electrical characteristics table, (e.g., 360 μA max at 25°C).



**CD54HC190, CD74HC190**  
**CD54HC191, CD74HC191, CD54HCT191, CD74HCT191**  
**SYNCHRONOUS UP/DOWN COUNTERS WITH DOWN/UP MODE CONTROL**

SCHS275E – MARCH 2002 – REVISED OCTOBER 2003

'HC190, 'HC191 timing requirements over recommended operating free-air temperature range (unless otherwise noted) (see Figure 4)

		V <sub>CC</sub>	T <sub>A</sub> = 25°C		T <sub>A</sub> = -55°C TO 125°C		T <sub>A</sub> = -40°C TO 85°C		UNIT
			MIN	MAX	MIN	MAX	MIN	MAX	
f <sub>clock</sub>	Clock frequency†	2 V	6		4		5		MHz
		4.5 V	30		20		25		
		6 V	35		23		29		
t <sub>w</sub>	$\overline{\text{LOAD}}$ low	2 V	80		120		100		ns
		4.5 V	16		24		20		
		6 V	14		20		17		
	CLK high or low	2 V	100		150		125		
		4.5 V	20		30		25		
		6 V	17		26		21		
t <sub>su</sub>	Data before $\overline{\text{LOAD}}\uparrow$	2 V	60		90		75		ns
		4.5 V	12		18		15		
		6 V	10		15		13		
	$\overline{\text{CTEN}}$ before CLK $\uparrow$	2 V	60		90		75		
		4.5 V	12		18		15		
		6 V	10		15		13		
	D/ $\overline{\text{U}}$ before CLK $\uparrow$	2 V	90		135		115		
		4.5 V	18		27		23		
		6 V	15		23		20		
t <sub>h</sub>	Data before $\overline{\text{LOAD}}\uparrow$	2 V	2		2		2		ns
		4.5 V	2		2		2		
		6 V	2		2		2		
	$\overline{\text{CTEN}}$ before CLK $\uparrow$	2 V	2		2		2		
		4.5 V	2		2		2		
		6 V	2		2		2		
	D/ $\overline{\text{U}}$ before CLK $\uparrow$	2 V	0		0		0		
		4.5 V	0		0		0		
		6 V	0		0		0		
t <sub>rec</sub>	$\overline{\text{LOAD}}$ inactive before CLK $\uparrow$	2 V	60		90		75		ns
		4.5 V	12		18		15		
		6 V	10		15		13		

† Applies to noncascaded operation only. With cascaded counters, clock-to-terminal count propagation delays, CTEN-to-clock setup times, and CTEN-to-clock hold times determine maximum clock frequency. For example, with these HC devices:

$$f_{\text{max}}(\text{CLK}) = \frac{1}{\text{CLK-to-MAX/MIN propagation delay} + \overline{\text{CTEN-to-CLK}} \text{ setup time} + \overline{\text{CTEN-to-CLK}} \text{ hold time}} = \frac{1}{42 + 12 + 2} \approx 18 \text{ MHz}$$



**CD54HC190, CD74HC190**  
**CD54HC191, CD74HC191, CD54HCT191, CD74HCT191**  
**SYNCHRONOUS UP/DOWN COUNTERS WITH DOWN/UP MODE CONTROL**

SCHS275E – MARCH 2002 – REVISED OCTOBER 2003

'HC190, 'HC191

switching characteristics over recommended operating free-air temperature range (unless otherwise noted) (see Figure 4)

PARAMETER	FROM (INPUT)	TO (OUTPUT)	LOAD CAPACITANCE	V <sub>CC</sub>	T <sub>A</sub> = 25°C			T <sub>A</sub> = -55°C TO 125°C		T <sub>A</sub> = -40°C TO 85°C		UNIT							
					MIN	TYP	MAX	MIN	MAX	MIN	MAX								
f <sub>max</sub>				2 V	6			4		5	MHz								
				4.5 V	30			20		25									
				6 V	35			23		29									
t <sub>pd</sub>	$\overline{\text{LOAD}}$	Q	C <sub>L</sub> = 50 pF	2 V		195		295		245	ns								
				4.5 V		39		59		49									
				6 V		33		50		42									
	A, B, C, or D	Q	C <sub>L</sub> = 50 pF	2 V		175		265		220									
				4.5 V		35		53		44									
				6 V		30		45		37									
	CLK	Q	C <sub>L</sub> = 50 pF	2 V		170		255		215									
				4.5 V		34		51		43									
				6 V		29		43		37									
	CLK	$\overline{\text{RCO}}$	C <sub>L</sub> = 50 pF	2 V		125		190		155									
				4.5 V		25		38		31									
				6 V		21		32		26									
	CLK	MAX/MIN	C <sub>L</sub> = 50 pF	2 V		210		315		265									
				4.5 V		42		63		53									
				6 V		36		54		45									
	D/ $\overline{\text{U}}$	$\overline{\text{RCO}}$	C <sub>L</sub> = 50 pF	2 V		150		225		190									
				4.5 V		30		45		38									
				6 V		26		38		33									
	D/ $\overline{\text{U}}$	MAX/MIN	C <sub>L</sub> = 50 pF	2 V		165		250		205									
				4.5 V		33		50		41									
				6 V		28		43		35									
	$\overline{\text{CTEN}}$	$\overline{\text{RCO}}$	C <sub>L</sub> = 50 pF	2 V		125		190		155									
				4.5 V		25		38		31									
				6 V		21		32		26									
	C <sub>L</sub> = 15 pF	5 V				16													
													5 V			14			
	5 V			10															
								5 V				10							
																5 V			13
	5 V			10															



**CD54HC190, CD74HC190**  
**CD54HC191, CD74HC191, CD54HCT191, CD74HCT191**  
**SYNCHRONOUS UP/DOWN COUNTERS WITH DOWN/UP MODE CONTROL**

SCHS275E – MARCH 2002 – REVISED OCTOBER 2003

**'HCT191**

timing requirements over recommended operating free-air temperature range  $V_{CC} = 4.5\text{ V}$  (unless otherwise noted) (see Figure 5)

		$T_A = 25^\circ\text{C}$		$T_A = -55^\circ\text{C}$ TO $125^\circ\text{C}$		$T_A = -40^\circ\text{C}$ TO $85^\circ\text{C}$		UNIT
		MIN	MAX	MIN	MAX	MIN	MAX	
$f_{\text{clock}}$	Clock frequency	30		20		25		MHz
$t_w$	Pulse duration	$\overline{\text{LOAD}}$ low	16	24	20			ns
		CLK high or low	20	30	25			
$t_{\text{su}}$	Setup time	Data before $\overline{\text{LOAD}}\uparrow$	12	18	15			ns
		$\overline{\text{CTEN}}$ before $\text{CLK}\uparrow$	12	18	15			
		$\text{D}/\overline{\text{U}}$ before $\text{CLK}\uparrow$	18	27	23			
$t_h$	Hold time	Data before $\overline{\text{LOAD}}\uparrow$	2	2	2			ns
		$\overline{\text{CTEN}}$ before $\text{CLK}\uparrow$	2	2	2			
		$\text{D}/\overline{\text{U}}$ before $\text{CLK}\uparrow$	0	0	0			
$t_{\text{rec}}$	Recovery time	$\overline{\text{LOAD}}$ inactive before $\text{CLK}\uparrow$	12	18	15			ns

**'HCT191**

switching characteristics over recommended operating free-air temperature range (unless otherwise noted) (see Figure 5)

PARAMETER	FROM (INPUT)	TO (OUTPUT)	LOAD CAPACITANCE	$V_{CC}$	$T_A = 25^\circ\text{C}$			$T_A = -55^\circ\text{C}$ TO $125^\circ\text{C}$		$T_A = -40^\circ\text{C}$ TO $85^\circ\text{C}$		UNIT
					MIN	TYP	MAX	MIN	MAX	MIN	MAX	
$f_{\text{max}}$				4.5 V	30			20		25		MHz
$t_{\text{pd}}$	$\overline{\text{LOAD}}$	Q	$C_L = 50\text{ pF}$	4.5 V		40		60		50		ns
			$C_L = 15\text{ pF}$	5 V	17							
	A, B, C, or D	Q	$C_L = 50\text{ pF}$	4.5 V		38		57		48		
			$C_L = 15\text{ pF}$	5 V	16							
	CLK	$\overline{\text{RCO}}$	$C_L = 50\text{ pF}$	4.5 V		35		53		44		
			$C_L = 15\text{ pF}$	5 V	14							
	CLK	Q	$C_L = 50\text{ pF}$	4.5 V		27		41		34		
			$C_L = 15\text{ pF}$	5 V	11							
	CLK	MAX/MIN	$C_L = 50\text{ pF}$	4.5 V		42		63		53		
			$C_L = 15\text{ pF}$	5 V	18							
	$\text{D}/\overline{\text{U}}$	$\overline{\text{RCO}}$	$C_L = 50\text{ pF}$	4.5 V		30		45		38		
			$C_L = 15\text{ pF}$	5 V	12							
	$\text{D}/\overline{\text{U}}$	MAX/MIN	$C_L = 50\text{ pF}$	4.5 V		38		57		48		
			$C_L = 15\text{ pF}$	5 V	16							
$\overline{\text{CTEN}}$	$\overline{\text{RCO}}$	$C_L = 50\text{ pF}$	4.5 V		27		41		34			
		$C_L = 15\text{ pF}$	5 V	11								
$t_t$		Any	$C_L = 50\text{ pF}$	4.5 V		15		22		19	ns	



**CD54HC190, CD74HC190**  
**CD54HC191, CD74HC191, CD54HCT191, CD74HCT191**  
**SYNCHRONOUS UP/DOWN COUNTERS WITH DOWN/UP MODE CONTROL**

SCHS275E – MARCH 2002 – REVISED OCTOBER 2003

operating characteristics,  $V_{CC} = 5\text{ V}$ ,  $T_A = 25^\circ\text{C}$

PARAMETER		TYP	UNIT
$C_{pd}$ Power dissipation capacitance	'HC190	59	pF
	'HC191	55	
	'HCT191	68	

**CD54HC190, CD74HC190**  
**CD54HC191, CD74HC191, CD54HCT191, CD74HCT191**  
**SYNCHRONOUS UP/DOWN COUNTERS WITH DOWN/UP MODE CONTROL**

SCHS275E – MARCH 2002 – REVISED OCTOBER 2003

**PARAMETER MEASUREMENT INFORMATION – 'HC190, 'HC191**

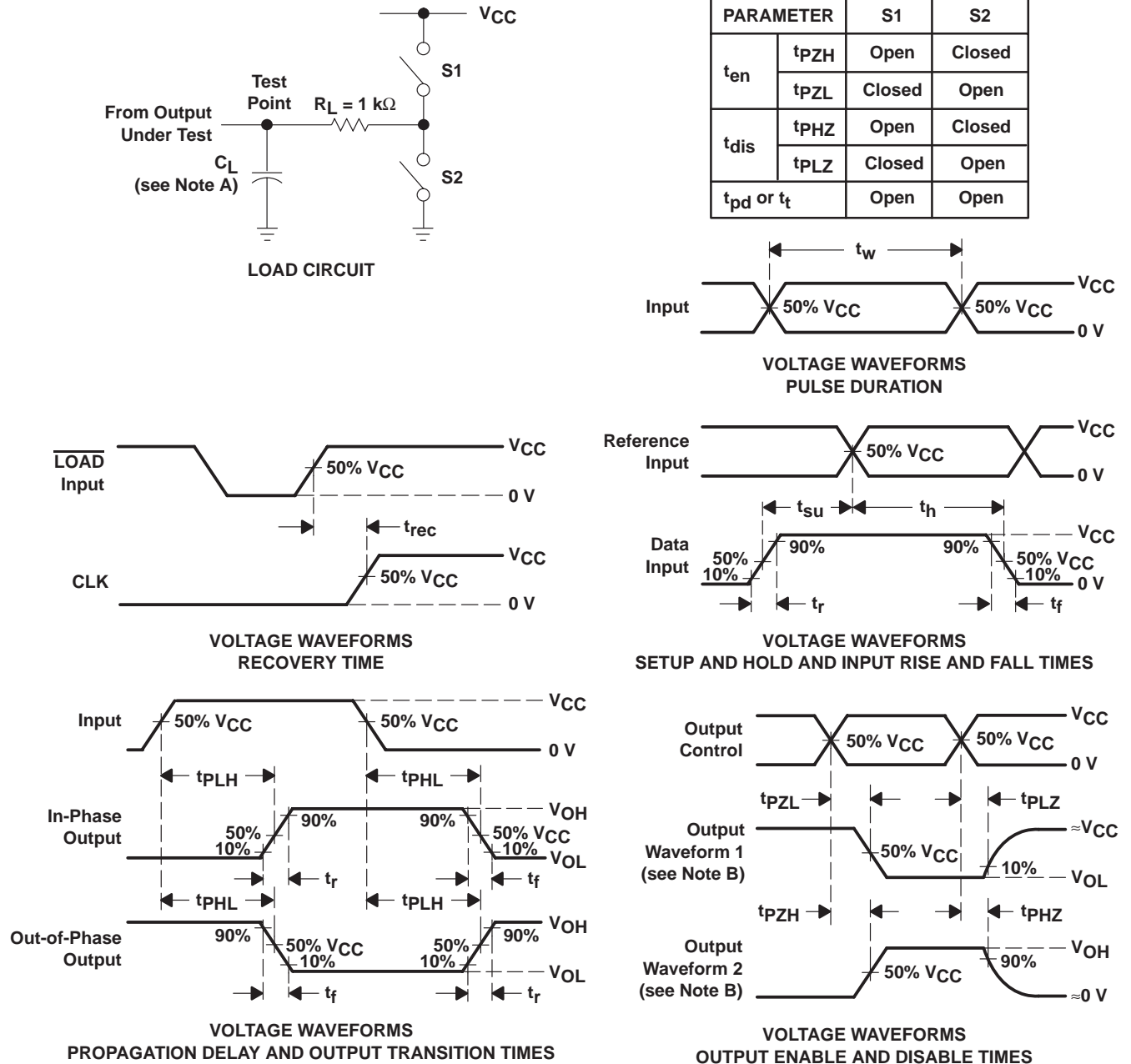

- NOTES: A.  $C_L$  includes probe and test-fixture capacitance.  
 B. Waveform 1 is for an output with internal conditions such that the output is low except when disabled by the output control. Waveform 2 is for an output with internal conditions such that the output is high except when disabled by the output control.  
 C. Phase relationships between waveforms were chosen arbitrarily. All input pulses are supplied by generators having the following characteristics:  $PRR \leq 1\text{ MHz}$ ,  $Z_O = 50\ \Omega$ ,  $t_r = 6\text{ ns}$ ,  $t_f = 6\text{ ns}$ .  
 D. For clock inputs,  $f_{max}$  is measured with the input duty cycle at 50%.  
 E. The outputs are measured one at a time with one input transition per measurement.  
 F.  $t_{PLZ}$  and  $t_{PHZ}$  are the same as  $t_{dis}$ .  
 G.  $t_{PZL}$  and  $t_{PZH}$  are the same as  $t_{en}$ .  
 H.  $t_{PLH}$  and  $t_{PHL}$  are the same as  $t_{pd}$ .

**Figure 4. Load Circuit and Voltage Waveforms**

**CD54HC190, CD74HC190**  
**CD54HC191, CD74HC191, CD54HCT191, CD74HCT191**  
**SYNCHRONOUS UP/DOWN COUNTERS WITH DOWN/UP MODE CONTROL**

SCHS275E – MARCH 2002 – REVISED OCTOBER 2003

**PARAMETER MEASUREMENT INFORMATION – 'HCT191**

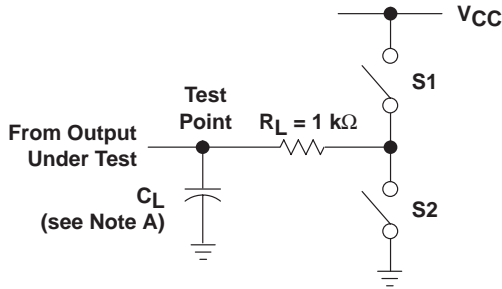

**LOAD CIRCUIT**

PARAMETER	S1	S2	
$t_{en}$	$t_{PZH}$	Open	Closed
	$t_{PZL}$	Closed	Open
$t_{dis}$	$t_{PHZ}$	Open	Closed
	$t_{PLZ}$	Closed	Open
$t_{pd}$ or $t_t$	Open	Open	

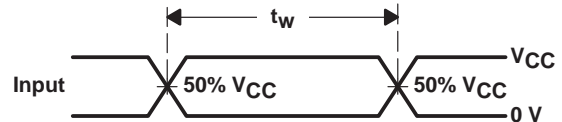

**VOLTAGE WAVEFORMS PULSE DURATION**

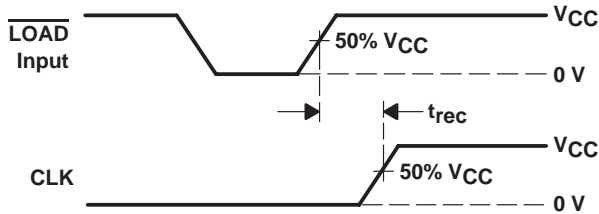

**VOLTAGE WAVEFORMS RECOVERY TIME**

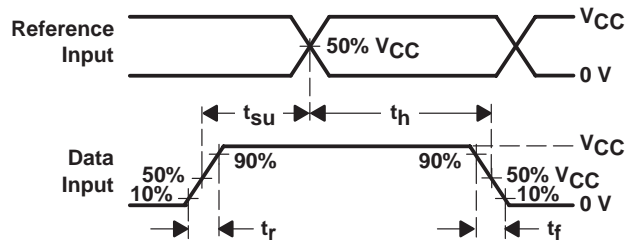

**VOLTAGE WAVEFORMS SETUP AND HOLD AND INPUT RISE AND FALL TIMES**

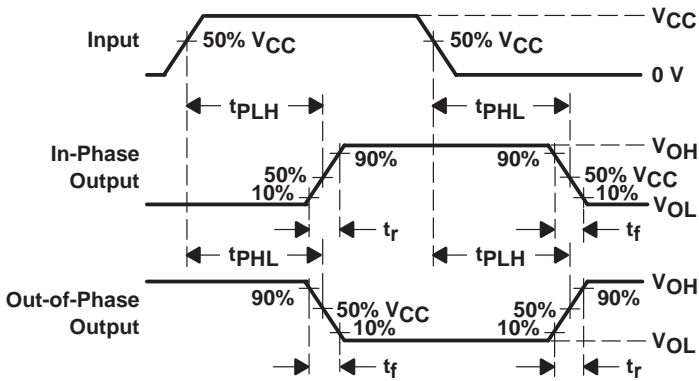

**VOLTAGE WAVEFORMS PROPAGATION DELAY AND OUTPUT TRANSITION TIMES**

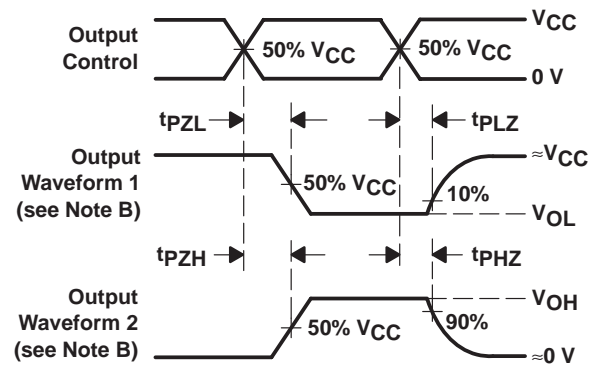

**VOLTAGE WAVEFORMS OUTPUT ENABLE AND DISABLE TIMES**

- NOTES: A.  $C_L$  includes probe and test-fixture capacitance.  
 B. Waveform 1 is for an output with internal conditions such that the output is low except when disabled by the output control. Waveform 2 is for an output with internal conditions such that the output is high except when disabled by the output control.  
 C. Phase relationships between waveforms were chosen arbitrarily. All input pulses are supplied by generators having the following characteristics:  $PRR \leq 1$  MHz,  $Z_O = 50 \Omega$ ,  $t_r = 6$  ns,  $t_f = 6$  ns.  
 D. For clock inputs,  $f_{max}$  is measured with the input duty cycle at 50%.  
 E. The outputs are measured one at a time with one input transition per measurement.  
 F.  $t_{PLZ}$  and  $t_{PHZ}$  are the same as  $t_{dis}$ .  
 G.  $t_{PZL}$  and  $t_{PZH}$  are the same as  $t_{en}$ .  
 H.  $t_{PLH}$  and  $t_{PHL}$  are the same as  $t_{pd}$ .

**Figure 5. Load Circuit and Voltage Waveforms**



**PACKAGING INFORMATION**

Orderable Device	Status (1)	Package Type	Package Drawing	Pins	Package Qty	Eco Plan (2)	Lead/Ball Finish (6)	MSL Peak Temp (3)	Op Temp (°C)	Device Marking (4/5)	Samples
5962-8867101EA	ACTIVE	CDIP	J	16	1	TBD	A42	N / A for Pkg Type	-55 to 125	5962-8867101EA CD54HCT191F3A	<a href="#">Samples</a>
5962-8994601EA	ACTIVE	CDIP	J	16	1	TBD	A42	N / A for Pkg Type	-55 to 125	5962-8994601EA CD54HC190F3A	<a href="#">Samples</a>
CD54HC190F3A	ACTIVE	CDIP	J	16	1	TBD	A42	N / A for Pkg Type	-55 to 125	5962-8994601EA CD54HC190F3A	<a href="#">Samples</a>
CD54HC191F3A	ACTIVE	CDIP	J	16	1	TBD	A42	N / A for Pkg Type	-55 to 125	5962-8689101EA CD54HC191F3A	<a href="#">Samples</a>
CD54HCT191F3A	ACTIVE	CDIP	J	16	1	TBD	A42	N / A for Pkg Type	-55 to 125	5962-8867101EA CD54HCT191F3A	<a href="#">Samples</a>
CD74HC190E	ACTIVE	PDIP	N	16	25	Green (RoHS & no Sb/Br)	CU NIPDAU	N / A for Pkg Type	-55 to 125	CD74HC190E	<a href="#">Samples</a>
CD74HC190EE4	ACTIVE	PDIP	N	16	25	Green (RoHS & no Sb/Br)	CU NIPDAU	N / A for Pkg Type	-55 to 125	CD74HC190E	<a href="#">Samples</a>
CD74HC190NSR	ACTIVE	SO	NS	16	2000	Green (RoHS & no Sb/Br)	CU NIPDAU	Level-1-260C-UNLIM	-55 to 125	HC190M	<a href="#">Samples</a>
CD74HC190PW	ACTIVE	TSSOP	PW	16	90	Green (RoHS & no Sb/Br)	CU NIPDAU	Level-1-260C-UNLIM	-55 to 125	HJ190	<a href="#">Samples</a>
CD74HC190PWR	ACTIVE	TSSOP	PW	16	2000	Green (RoHS & no Sb/Br)	CU NIPDAU	Level-1-260C-UNLIM	-55 to 125	HJ190	<a href="#">Samples</a>
CD74HC191E	ACTIVE	PDIP	N	16	25	Green (RoHS & no Sb/Br)	CU NIPDAU	N / A for Pkg Type	-55 to 125	CD74HC191E	<a href="#">Samples</a>
CD74HC191EE4	ACTIVE	PDIP	N	16	25	Green (RoHS & no Sb/Br)	CU NIPDAU	N / A for Pkg Type	-55 to 125	CD74HC191E	<a href="#">Samples</a>
CD74HC191M	ACTIVE	SOIC	D	16	40	Green (RoHS & no Sb/Br)	CU NIPDAU	Level-1-260C-UNLIM	-55 to 125	HC191M	<a href="#">Samples</a>
CD74HC191M96	ACTIVE	SOIC	D	16	2500	Green (RoHS & no Sb/Br)	CU NIPDAU	Level-1-260C-UNLIM	-55 to 125	HC191M	<a href="#">Samples</a>
CD74HC191M96E4	ACTIVE	SOIC	D	16	2500	Green (RoHS & no Sb/Br)	CU NIPDAU	Level-1-260C-UNLIM	-55 to 125	HC191M	<a href="#">Samples</a>
CD74HC191MG4	ACTIVE	SOIC	D	16	40	Green (RoHS & no Sb/Br)	CU NIPDAU	Level-1-260C-UNLIM	-55 to 125	HC191M	<a href="#">Samples</a>
CD74HC191MT	ACTIVE	SOIC	D	16	250	Green (RoHS & no Sb/Br)	CU NIPDAU	Level-1-260C-UNLIM	-55 to 125	HC191M	<a href="#">Samples</a>

Orderable Device	Status (1)	Package Type	Package Drawing	Pins	Package Qty	Eco Plan (2)	Lead/Ball Finish (6)	MSL Peak Temp (3)	Op Temp (°C)	Device Marking (4/5)	Samples
CD74HCT191E	ACTIVE	PDIP	N	16	25	Green (RoHS & no Sb/Br)	CU NIPDAU	N / A for Pkg Type	-55 to 125	CD74HCT191E	<a href="#">Samples</a>
CD74HCT191M	ACTIVE	SOIC	D	16	40	Green (RoHS & no Sb/Br)	CU NIPDAU	Level-1-260C-UNLIM	-55 to 125	HCT191M	<a href="#">Samples</a>

(1) The marketing status values are defined as follows:

**ACTIVE:** Product device recommended for new designs.

**LIFEBUY:** TI has announced that the device will be discontinued, and a lifetime-buy period is in effect.

**NRND:** Not recommended for new designs. Device is in production to support existing customers, but TI does not recommend using this part in a new design.

**PREVIEW:** Device has been announced but is not in production. Samples may or may not be available.

**OBSOLETE:** TI has discontinued the production of the device.

(2) **RoHS:** TI defines "RoHS" to mean semiconductor products that are compliant with the current EU RoHS requirements for all 10 RoHS substances, including the requirement that RoHS substance do not exceed 0.1% by weight in homogeneous materials. Where designed to be soldered at high temperatures, "RoHS" products are suitable for use in specified lead-free processes. TI may reference these types of products as "Pb-Free".

**RoHS Exempt:** TI defines "RoHS Exempt" to mean products that contain lead but are compliant with EU RoHS pursuant to a specific EU RoHS exemption.

**Green:** TI defines "Green" to mean the content of Chlorine (Cl) and Bromine (Br) based flame retardants meet JS709B low halogen requirements of <=1000ppm threshold. Antimony trioxide based flame retardants must also meet the <=1000ppm threshold requirement.

(3) MSL, Peak Temp. - The Moisture Sensitivity Level rating according to the JEDEC industry standard classifications, and peak solder temperature.

(4) There may be additional marking, which relates to the logo, the lot trace code information, or the environmental category on the device.

(5) Multiple Device Markings will be inside parentheses. Only one Device Marking contained in parentheses and separated by a "~" will appear on a device. If a line is indented then it is a continuation of the previous line and the two combined represent the entire Device Marking for that device.

(6) Lead/Ball Finish - Orderable Devices may have multiple material finish options. Finish options are separated by a vertical ruled line. Lead/Ball Finish values may wrap to two lines if the finish value exceeds the maximum column width.

**Important Information and Disclaimer:**The information provided on this page represents TI's knowledge and belief as of the date that it is provided. TI bases its knowledge and belief on information provided by third parties, and makes no representation or warranty as to the accuracy of such information. Efforts are underway to better integrate information from third parties. TI has taken and continues to take reasonable steps to provide representative and accurate information but may not have conducted destructive testing or chemical analysis on incoming materials and chemicals. TI and TI suppliers consider certain information to be proprietary, and thus CAS numbers and other limited information may not be available for release.

In no event shall TI's liability arising out of such information exceed the total purchase price of the TI part(s) at issue in this document sold by TI to Customer on an annual basis.

**OTHER QUALIFIED VERSIONS OF CD54HC190, CD54HC191, CD54HCT191, CD74HC190, CD74HC191, CD74HCT191 :**

- Catalog: [CD74HC190](#), [CD74HC191](#), [CD74HCT191](#)
- Military: [CD54HC190](#), [CD54HC191](#), [CD54HCT191](#)

NOTE: Qualified Version Definitions:

- Catalog - TI's standard catalog product
- Military - QML certified for Military and Defense Applications

**TAPE AND REEL INFORMATION**

**QUADRANT ASSIGNMENTS FOR PIN 1 ORIENTATION IN TAPE**

\*All dimensions are nominal

Device	Package Type	Package Drawing	Pins	SPQ	Reel Diameter (mm)	Reel Width W1 (mm)	A0 (mm)	B0 (mm)	K0 (mm)	P1 (mm)	W (mm)	Pin1 Quadrant
CD74HC190NSR	SO	NS	16	2000	330.0	16.4	8.2	10.5	2.5	12.0	16.0	Q1
CD74HC190PWR	TSSOP	PW	16	2000	330.0	12.4	6.9	5.6	1.6	8.0	12.0	Q1
CD74HC191M96	SOIC	D	16	2500	330.0	16.4	6.5	10.3	2.1	8.0	16.0	Q1

**TAPE AND REEL BOX DIMENSIONS**

\*All dimensions are nominal

Device	Package Type	Package Drawing	Pins	SPQ	Length (mm)	Width (mm)	Height (mm)
CD74HC190NSR	SO	NS	16	2000	367.0	367.0	38.0
CD74HC190PWR	TSSOP	PW	16	2000	367.0	367.0	35.0
CD74HC191M96	SOIC	D	16	2500	333.2	345.9	28.6

D (R-PDSO-G16)

PLASTIC SMALL OUTLINE



4040047-6/M 06/11

- NOTES:
- A. All linear dimensions are in inches (millimeters).
  - B. This drawing is subject to change without notice.
  -  C. Body length does not include mold flash, protrusions, or gate burrs. Mold flash, protrusions, or gate burrs shall not exceed 0.006 (0,15) each side.
  -  D. Body width does not include interlead flash. Interlead flash shall not exceed 0.017 (0,43) each side.
  - E. Reference JEDEC MS-012 variation AC.

D (R-PDSO-G16)

PLASTIC SMALL OUTLINE



4211283-4/E 08/12

- NOTES:
- All linear dimensions are in millimeters.
  - This drawing is subject to change without notice.
  - Publication IPC-7351 is recommended for alternate designs.
  - Laser cutting apertures with trapezoidal walls and also rounding corners will offer better paste release. Customers should contact their board assembly site for stencil design recommendations. Refer to IPC-7525 for other stencil recommendations.
  - Customers should contact their board fabrication site for solder mask tolerances between and around signal pads.

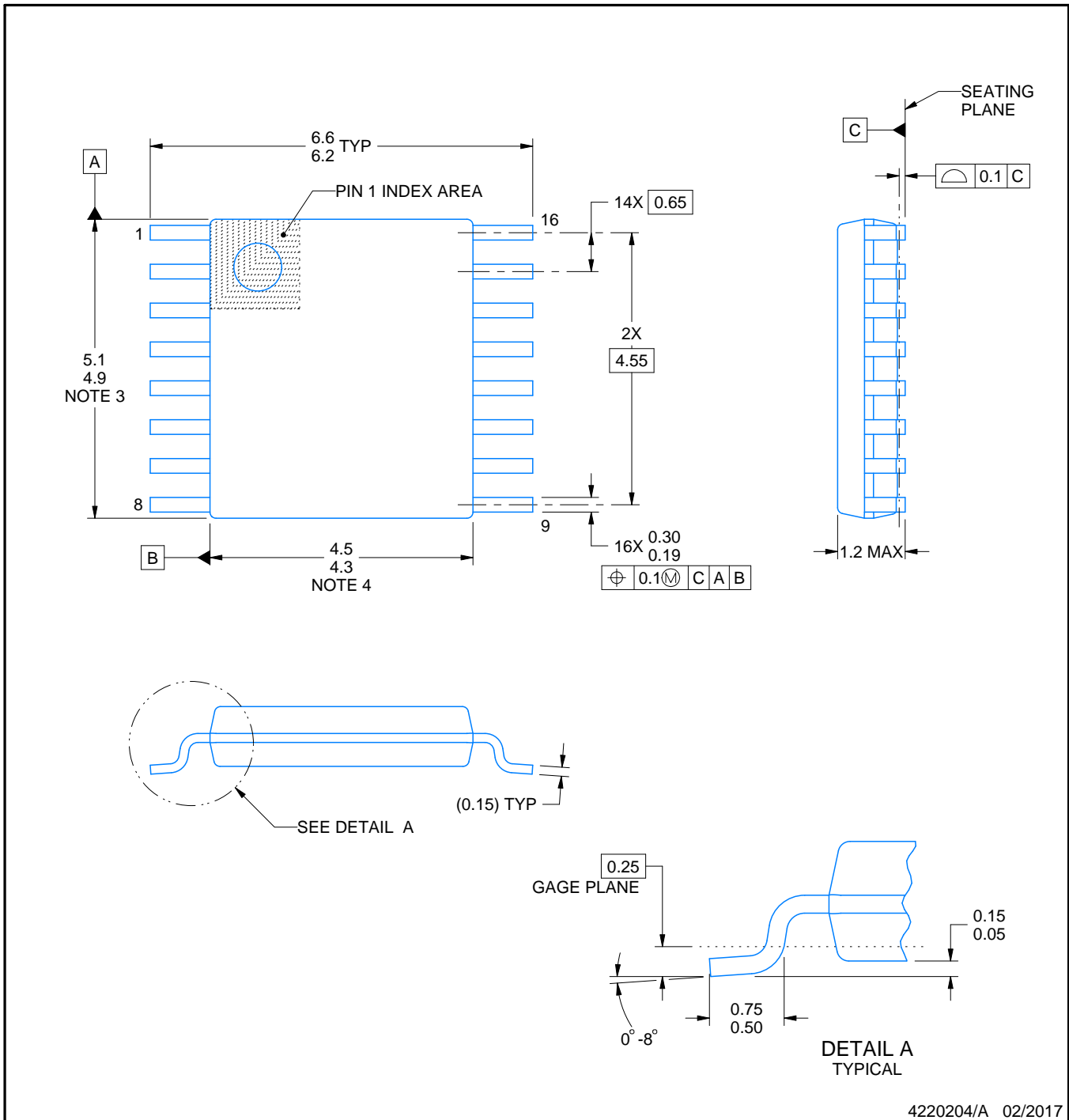

4220204/A 02/2017

**NOTES:**

1. All linear dimensions are in millimeters. Any dimensions in parenthesis are for reference only. Dimensioning and tolerancing per ASME Y14.5M.
2. This drawing is subject to change without notice.
3. This dimension does not include mold flash, protrusions, or gate burrs. Mold flash, protrusions, or gate burrs shall not exceed 0.15 mm per side.
4. This dimension does not include interlead flash. Interlead flash shall not exceed 0.25 mm per side.
5. Reference JEDEC registration MO-153.

# EXAMPLE BOARD LAYOUT

PW0016A

TSSOP - 1.2 mm max height

SMALL OUTLINE PACKAGE



LAND PATTERN EXAMPLE  
EXPOSED METAL SHOWN  
SCALE: 10X



SOLDER MASK DETAILS

4220204/A 02/2017

NOTES: (continued)

- 6. Publication IPC-7351 may have alternate designs.
- 7. Solder mask tolerances between and around signal pads can vary based on board fabrication site.

# EXAMPLE STENCIL DESIGN

PW0016A

TSSOP - 1.2 mm max height

SMALL OUTLINE PACKAGE



SOLDER PASTE EXAMPLE  
BASED ON 0.125 mm THICK STENCIL  
SCALE: 10X

4220204/A 02/2017

NOTES: (continued)

8. Laser cutting apertures with trapezoidal walls and rounded corners may offer better paste release. IPC-7525 may have alternate design recommendations.
9. Board assembly site may have different recommendations for stencil design.

# MECHANICAL DATA

NS (R-PDSO-G\*\*)

PLASTIC SMALL-OUTLINE PACKAGE

14-PINS SHOWN



- NOTES:
- A. All linear dimensions are in millimeters.
  - B. This drawing is subject to change without notice.
  - C. Body dimensions do not include mold flash or protrusion, not to exceed 0,15.

J (R-GDIP-T\*\*)

14 LEADS SHOWN

CERAMIC DUAL IN-LINE PACKAGE



DIM \ PINS **	14	16	18	20
A	0.300 (7,62) BSC	0.300 (7,62) BSC	0.300 (7,62) BSC	0.300 (7,62) BSC
B MAX	0.785 (19,94)	.840 (21,34)	0.960 (24,38)	1.060 (26,92)
B MIN	—	—	—	—
C MAX	0.300 (7,62)	0.300 (7,62)	0.310 (7,87)	0.300 (7,62)
C MIN	0.245 (6,22)	0.245 (6,22)	0.220 (5,59)	0.245 (6,22)



4040083/F 03/03

- NOTES:
- All linear dimensions are in inches (millimeters).
  - This drawing is subject to change without notice.
  - This package is hermetically sealed with a ceramic lid using glass frit.
  - Index point is provided on cap for terminal identification only on press ceramic glass frit seal only.
  - Falls within MIL STD 1835 GDIP1-T14, GDIP1-T16, GDIP1-T18 and GDIP1-T20.

N (R-PDIP-T\*\*)

PLASTIC DUAL-IN-LINE PACKAGE

16 PINS SHOWN



- NOTES:
- A. All linear dimensions are in inches (millimeters).
  - B. This drawing is subject to change without notice.
  - Falls within JEDEC MS-001, except 18 and 20 pin minimum body length (Dim A).
  - The 20 pin end lead shoulder width is a vendor option, either half or full width.

## IMPORTANT NOTICE AND DISCLAIMER

TI PROVIDES TECHNICAL AND RELIABILITY DATA (INCLUDING DATASHEETS), DESIGN RESOURCES (INCLUDING REFERENCE DESIGNS), APPLICATION OR OTHER DESIGN ADVICE, WEB TOOLS, SAFETY INFORMATION, AND OTHER RESOURCES "AS IS" AND WITH ALL FAULTS, AND DISCLAIMS ALL WARRANTIES, EXPRESS AND IMPLIED, INCLUDING WITHOUT LIMITATION ANY IMPLIED WARRANTIES OF MERCHANTABILITY, FITNESS FOR A PARTICULAR PURPOSE OR NON-INFRINGEMENT OF THIRD PARTY INTELLECTUAL PROPERTY RIGHTS.

These resources are intended for skilled developers designing with TI products. You are solely responsible for (1) selecting the appropriate TI products for your application, (2) designing, validating and testing your application, and (3) ensuring your application meets applicable standards, and any other safety, security, or other requirements. These resources are subject to change without notice. TI grants you permission to use these resources only for development of an application that uses the TI products described in the resource. Other reproduction and display of these resources is prohibited. No license is granted to any other TI intellectual property right or to any third party intellectual property right. TI disclaims responsibility for, and you will fully indemnify TI and its representatives against, any claims, damages, costs, losses, and liabilities arising out of your use of these resources.

TI's products are provided subject to TI's Terms of Sale ([www.ti.com/legal/termsofsale.html](http://www.ti.com/legal/termsofsale.html)) or other applicable terms available either on [ti.com](http://ti.com) or provided in conjunction with such TI products. TI's provision of these resources does not expand or otherwise alter TI's applicable warranties or warranty disclaimers for TI products.

Mailing Address: Texas Instruments, Post Office Box 655303, Dallas, Texas 75265  
Copyright © 2018, Texas Instruments Incorporated

## Looking for pricing, stock, or lifecycle information?

Click below to explore more details on WIN SOURCE:

 [View CD74HC191MT](#) on WIN SOURCE

 [Texas Instruments](#) Information

## Optimize Your Supply Chain with WIN SOURCE Solutions

-  Global Sourcing Solution
-  Obsolete Management
-  Cost Control Management
-  Shortage Management
-  Alternative Solution
-  Excess Inventory Management