



**THE DATASHEET OF  
CC1260RGZT**



## Sub-1-GHz RF I/Q Front End for Software-Defined Radio and IEEE 802.15.4g

### 1 Device Overview

#### 1.1 Features

- General
  - Supported Frequency Bands: 863 to 876 MHz and 902 to 930 MHz
  - Wide Supply Voltage Range: 2.3 to 3.6 V
  - Temperature Range: –40°C to +105°C
  - High-Performance Single-Chip Linear Quadrature RF Transceiver With a Digitized I/Q Interface to a DSP
  - Suitable for Systems Targeting Compliance With:
    - FCC 47 CFR Part 15
    - ARIB STD-T108
    - ETSI EN 300 220
    - ETSI EN 303 204
  - Low Current Consumption
    - RX: 32 mA
    - TX:
      - 48 mA @ +10 dBm
      - 42 mA @ +3 dBm
    - Power Down: <1  $\mu$ A
    - Excellent Phase Noise
      - –101 dBc/Hz at 10-kHz Offset
      - –123 dBc/Hz at 1-MHz Offset
  - Low Cascaded Receiver Noise Figure: 7 dB
  - Industry-Leading RF Coexistence Properties
- Blocking (3-dB Desensitization):
  - –33 dBm at 10-MHz Offset
  - –36 dBm at 2-MHz Offset
- High-Performance Linear RF Front End
  - Tailored for All IEEE 802.15.4g PHY Options (MR-FSK, MR-OFDM, MR-O-QPSK [DSSS]) Using the Modulation Formats (G)FSK, O-QPSK, BPSK, QPSK, and 16-QAM
  - RF I/Q Up- and Down-Conversion With Digitized Baseband Input and Output Signals
  - Fully Integrated High-Performance Frequency Synthesizer and Quadrature LO Signal Generator
  - Programmable Output Power up to +13 dBm for Nonlinear Modulation Formats, Such as FSK and up to 3-dBm Average Power for 16-QAM OFDM With Very Fine Step Size
- Receive Gain: 43 dB
- TX Error Vector Magnitude (EVM): –29 dB
- Seamless Parallel Interface to DSP
- RoHS Compliant 7-mm  $\times$  7-mm RGZ-48 Package
- Optional Reference Clock Output to Facilitate Single Crystal Wireless System Designs

#### 1.2 Applications

- High-Performance, Low-Power, Software-Defined Radio (SDR) Systems at 868-, 915-, and 920-MHz ISM Frequency Bands
- Wireless Smart Grid
- Automated Metering Infrastructure (AMI) and Automatic Meter Reading (AMR)
- Industrial Monitoring and Control
- Support for All IEEE 802.15.4g PHY Modes



### 1.3 Description

The CC1260 device contains a quadrature RF front end with a digitized baseband signal interface targeting software-defined radio systems. The combination of the CC1260 device and a DSP is tailored for high performance and flexible FSK, OFDM, and DSSS designs (including IEEE 802.15.4g MR-FSK, MR-OFDM, and MR-O-QPSK PHY options). The CC1260 device is designed for excellent performance at very low-power and low-voltage operation in cost-effective wireless systems. The device is mainly intended for the industrial, scientific, and medical (ISM) 863- to 876-MHz and 902- to 930-MHz frequency bands. A typical CC1260-based system design requires only a few external passive components, a DSP (for the digital modem), and a microcontroller (for system control and application). The main operating parameters of the CC1260 device can be controlled using an SPI interface.

Table 1-1. Device Information

PART NUMBER	PACKAGE	BODY SIZE
CC1260RGZR	RGZ (48)	7 mm × 7 mm
CC1260RGZT	RGZ (48)	7 mm × 7 mm

### 1.4 Functional Block Diagram

Figure 1-1 shows a functional block diagram of the CC1260 device. The CC1260 device can be used as an I/Q RF front end with a digitized interface to an external implementation of the modem functionality using, for example, a DSP. The receiver input can be matched in a differential or single-ended fashion to a 50-Ω impedance. The digital I/Q interface is tailored to fit seamlessly with TI DSP devices.

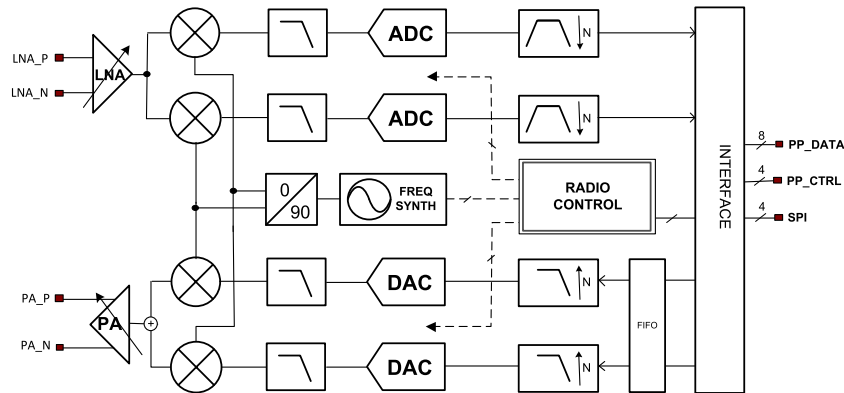


Figure 1-1. CC1260 Functional Block Diagram

## Table of Contents

<b>1</b>	<b>Device Overview</b> .....	<a href="#">1</a>	4.14	General I/O (GPIO, SPI, and RESET_N Pin) .....	<a href="#">11</a>
1.1	Features .....	<a href="#">1</a>	4.15	uPP Interface .....	<a href="#">11</a>
1.2	Applications .....	<a href="#">1</a>	4.16	Temperature Sensor .....	<a href="#">12</a>
1.3	Description .....	<a href="#">2</a>	4.17	Voltage Sensor .....	<a href="#">12</a>
1.4	Functional Block Diagram .....	<a href="#">2</a>	4.18	Typical Characteristics .....	<a href="#">13</a>
<b>2</b>	<b>Revision History</b> .....	<a href="#">3</a>	<b>5</b>	<b>Detailed Description</b> .....	<a href="#">17</a>
<b>3</b>	<b>Terminal Configuration and Functions</b> .....	<a href="#">4</a>	5.1	Functional Block Diagram .....	<a href="#">17</a>
3.1	Pin Diagram .....	<a href="#">4</a>	5.2	Frequency Synthesizer .....	<a href="#">17</a>
3.2	Pin Attributes .....	<a href="#">4</a>	5.3	Receiver .....	<a href="#">17</a>
<b>4</b>	<b>Specifications</b> .....	<a href="#">6</a>	5.4	Transmitter .....	<a href="#">19</a>
4.1	Absolute Maximum Ratings .....	<a href="#">6</a>	5.5	Radio Control and User Interface .....	<a href="#">20</a>
4.2	Handling Ratings .....	<a href="#">6</a>	<b>6</b>	<b>Applications, Implementation, and Layout</b> .....	<a href="#">23</a>
4.3	Recommended Operating Conditions .....	<a href="#">6</a>	6.1	Typical Application .....	<a href="#">23</a>
4.4	Thermal Resistance Characteristics for RGZ Package .....	<a href="#">6</a>	6.2	Calibration .....	<a href="#">23</a>
4.5	RF Characteristics .....	<a href="#">7</a>	<b>7</b>	<b>Device and Documentation Support</b> .....	<a href="#">24</a>
4.6	Current Consumption .....	<a href="#">7</a>	7.1	Community Resources .....	<a href="#">24</a>
4.7	Receive Parameters .....	<a href="#">7</a>	7.2	Trademarks .....	<a href="#">24</a>
4.8	Transmit Parameters .....	<a href="#">8</a>	7.3	Electrostatic Discharge Caution .....	<a href="#">24</a>
4.9	Frequency Synthesizer .....	<a href="#">10</a>	7.4	Glossary .....	<a href="#">24</a>
4.10	Wake-Up and Timing .....	<a href="#">10</a>	<b>8</b>	<b>Mechanical Packaging and Orderable Information</b> .....	<a href="#">25</a>
4.11	Crystal Oscillator .....	<a href="#">10</a>	8.1	VQFN Mechanical Data .....	<a href="#">25</a>
4.12	Clock Output .....	<a href="#">11</a>	8.2	Tape and Reel Dimensions .....	<a href="#">28</a>
4.13	Clock Input (TCXO) .....	<a href="#">11</a>			

## 2 Revision History

Changes from Revision B (August 2014) to Revision C	Page
• Added 863 to 876 MHz support .....	<a href="#">1</a>
• Added 868-MHz frequency band to SDR systems .....	<a href="#">1</a>
• Changed title of <a href="#">Section 4.3</a> , <i>Recommended Operating Conditions</i> from <i>General Characteristics</i> .....	<a href="#">6</a>
• Added <a href="#">Section 4.4</a> , <i>Thermal Resistance Characteristics for RGZ Package</i> .....	<a href="#">6</a>
• Added conditions to <a href="#">Section 4.6</a> , <i>Current Consumption</i> .....	<a href="#">7</a>
• Changed "The optional clock output is available in all modes except POWERDOWN and XOFF." to read "The optional clock output is always available unless the device is in POWERDOWN or XOFF mode." .....	<a href="#">20</a>

### 3 Terminal Configuration and Functions

#### 3.1 Pin Diagram

Figure 3-1 shows the pin designations for the CC1260 device.

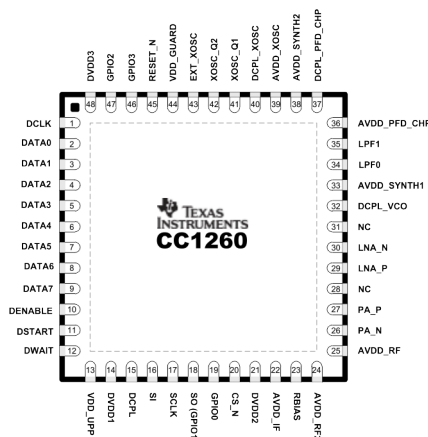


Figure 3-1. CC1260 48-Pin RGZ

#### 3.2 Pin Attributes

Table 3-1 describes the CC1260 signals.

Table 3-1. Pin Attributes

PIN NUMBER	SIGNAL NAME	SIGNAL TYPE	DESCRIPTION
1	DCLK	Digital I/O	uPP interface clock
2	DATA0	Digital I/O	uPP interface data line
3	DATA1	Digital I/O	uPP interface data line
4	DATA2	Digital I/O	uPP interface data line
5	DATA3	Digital I/O	uPP interface data line
6	DATA4	Digital I/O	uPP interface data line
7	DATA5	Digital I/O	uPP interface data line
8	DATA6	Digital I/O	uPP interface data line
9	DATA7	Digital I/O	uPP interface data line
10	DENABLE	Digital I/O	uPP interface enable
11	DSTART	Digital I/O	uPP interface start
12	DWAIT	Digital output	uPP interface wait
13	VDD_UPP	Power	1.6- to 2.0-V VDD
14	DVDD1	Power	2.3- to 3.6-V VDD
15	DCPL	Power	Digital regulator output to external decoupling capacitor
16	SI	Digital input	Serial data in
17	SCLK	Digital input	Serial data clock
18	SO (GPIO1)	Digital I/O	Serial data out (General-purpose I/O)
19	GPIO0	Digital I/O	General-purpose I/O
20	CS_N	Digital input	Active-low chip select
21	DVDD2	Power	2.3- to 3.6-V VDD
22	AVDD_IF	Power	2.3- to 3.6-V VDD
23	RBIAS	Analog	External high-precision resistor
24	AVDD_RF2	Power	2.3- to 3.6-V VDD

**Table 3-1. Pin Attributes (continued)**

PIN NUMBER	SIGNAL NAME	SIGNAL TYPE	DESCRIPTION
25	AVDD_RF	Power	2.3- to 3.6-V VDD
26	PA_N	Analog	Differential TX output
27	PA_P	Analog	Differential TX output
28	NC		Not connected
29	LNA_P	Analog	Differential RX input
30	LNA_N	Analog	Differential RX input
31	NC		Not connected
32	DCPL_VCO	Power	Pin for external decoupling of VCO supply regulator
33	AVDD_SYNTH1	Power	2.3- to 3.6-V VDD
34	LPF0	Analog	External loop filter components
35	LPF1	Analog	External loop filter components
36	AVDD_PFD_CHP	Power	2.3- to 3.6-V VDD
37	DCPL_PFD_CHP	Power	Pin for external decoupling of PFD and CHP regulator
38	AVDD_SYNTH2	Power	2.3- to 3.6-V VDD
39	AVDD_XOSC	Power	2.3- to 3.6-V VDD
40	DCPL_XOSC	Power	Pin for external decoupling of XOSC supply regulator
41	XOSC_Q1	Analog	Crystal oscillator pin 1 (must be grounded if a TCXO or other external clock connected to EXT_XOSC is used)
42	XOSC_Q2	Analog	Crystal oscillator pin 2 (must be left floating if a TCXO or other external clock connected to EXT_XOSC is used)
43	EXT_XOSC	Digital input	Pin for external XOSC input (must be grounded if a regular XOSC connected to XOSC_Q1 and XOSC_Q2 is used)
44	VDD_GUARD	Power	2.3- to 3.6-V VDD
45	RESET_N	Digital input	Asynchronous, active-low digital reset
46	GPIO3	Digital I/O	General-purpose I/O (Default state: 20 MHz clock output)
47	GPIO2	Digital I/O	General-purpose I/O
48	DVDD3	Power	2.3- to 3.6-V VDD
–	GND	Ground pad	The ground pad must be connected to a solid ground plane.

## 4 Specifications

All measurements are performed on CC1260EM\_FPGA R0.8 or on the production test platform. The test signal in TX (such as FSK and OFDM) is generated by an external FPGA.

### 4.1 Absolute Maximum Ratings

PARAMETER	CONDITION	MIN	TYP	MAX	UNIT
Supply voltage (VDD)		–0.3		3.9	V
Input RF level				+10	dBm
Voltage on digital pins (except uPP interface)		–0.3		VDD+0.3 max 3.9	V
Voltage on analog pins (including DCPL pins)		–0.3		2.0	V
Voltage on uPP interface (including VDD_UPP)		–0.3		2.0	V

### 4.2 Handling Ratings

		MIN	MAX	UNIT
T <sub>stg</sub>	Storage temperature range	–40	+125	°C
V <sub>ESD</sub>	Human body model (HBM) stress voltage, per ANSI/ESDA/JEDEC JS-01, all pins <sup>(1)</sup>	–2000	+2000	V
	Charged device model (CDM) ESD stress voltage, per JEDEC specification JESD22-C101, all pins <sup>(2)</sup>	–1000	+1000	V

- (1) JEDEC document JEP155 states that 500-V HBM allows safe manufacturing with a standard ESD control process. Pins listed as 2000 V may actually have higher performance.
- (2) JEDEC document JEP155 states that 250-V CDM allows safe manufacturing with a standard ESD control process. Pins listed as 1000 V may actually have higher performance.

### 4.3 Recommended Operating Conditions

PARAMETER	CONDITION	MIN	TYP	MAX	UNIT
Voltage supply range		2.3		3.6	V
uPP interface voltage		1.6		2.0	V
Temperature range		–40		105	°C

### 4.4 Thermal Resistance Characteristics for RGZ Package

NAME	DESCRIPTION	°C/W <sup>(1) (2)</sup>	AIR FLOW (m/s) <sup>(3)</sup>
R <sub>θJCT</sub>	Junction to case (top)	14.5	0.0
R <sub>θJCB</sub>	Junction to case (bottom)	1.2	0.0
R <sub>θJB</sub>	Junction to board	5.2	0.0
R <sub>θJA</sub>	Junction to free air (high K)	28.3	0.0
Ψ <sub>JT</sub>	Junction to package (top)	0.2	0.0
Ψ <sub>JB</sub>	Junction to board	5.2	0.0

- (1) °C/W = degrees Celsius per watt
- (2) These values are based on a JEDEC-defined 2S2P system (with the exception of the Theta-JC [R<sub>θJC</sub>] value, which is based on a JEDEC-defined 1S0P system) and changes based on environment as well as application. For more information, see these EIA/JEDEC standards:
- JESD51-2, *Integrated Circuits Thermal Test Method Environmental Conditions - Natural Convection (Still Air)*
  - JESD51-3, *Low Effective Thermal Conductivity Test Board for Leaded Surface Mount Packages*
  - JESD51-7, *High Effective Thermal Conductivity Test Board for Leaded Surface Mount Packages*
  - JESD51-9, *Test Boards for Area Array Surface Mount Package Thermal Measurements*
- Assumes power dissipation of 2 W and an ambient temperature of 70°C
- (3) m/s = meters per second

## 4.5 RF Characteristics

$T_A = 25^\circ\text{C}$ ,  $V_{DD} = 3.3\text{ V}$ ,  $f_c = 915\text{ MHz}$ ,  $f_{\text{xtal}} = 40\text{ MHz}$  if nothing else stated

PARAMETER	CONDITION	MIN	TYP	MAX	UNIT
Frequency bands		902		930	MHz
		863		876	MHz
Channel bandwidth	Minimum channel bandwidth is defined by DSP filtering and crystal tolerance. Bandwidths are scaled by the crystal frequency.	Receive		2	MHz
		Transmit		3	MHz

## 4.6 Current Consumption

$T_A = 25^\circ\text{C}$ ,  $V_{DD} = 3.3\text{ V}$ ,  $f_c = 915\text{ MHz}$ ,  $f_{\text{xtal}} = 40\text{ MHz}$  if nothing else stated

PARAMETER	CONDITION	MIN	TYP	MAX	UNIT
Power down	Optional clock output not available		0.3	<1	$\mu\text{A}$
XOFF mode	Optional clock output not available		190		$\mu\text{A}$
IDLE mode			2.7		mA
RX current consumption	At 2 Msps sample rate		32		mA
TX current consumption:					
Transmitting FSK, +3 dBm			42		mA
Transmitting FSK, +10 dBm			48		
Transmitting FSK, max output power			57		

## 4.7 Receive Parameters

$T_A = 25^\circ\text{C}$ ,  $V_{DD} = 3.3\text{ V}$ ,  $f_c = 915\text{ MHz}$ ,  $f_{\text{xtal}} = 40\text{ MHz}$  if nothing else stated

PARAMETER	CONDITION	MIN	TYP	MAX	UNIT
Noise figure: 1.6-MHz I/Q bandwidth (includes noise contribution from ADC)	RX calibration before entering RX required		6		dB
Noise figure: 2-MHz I/Q bandwidth (includes noise contribution from ADC)	RX calibration before entering RX required		7		
Noise figure: 200-kHz I/Q bandwidth centered around zero (includes noise contribution from ADC)	RX calibration before entering RX required		8		dB
	DC filter required		7		
Blocking/selectivity: Digital filter bandwidth of approximately 150 kHz with a Cascaded Integrator-Comb (CIC) filter decimation factor $M = 64$ and using minimum AAF bandwidth 3-dB signal-to-noise reduction	$\pm 400\text{ kHz}$ offset		-53		dBm
	$\pm 800\text{ kHz}$ offset		-44		
	$\pm 2\text{ MHz}$ offset		-36		
	$\pm 10\text{ MHz}$ offset		-33		
IIP2 (low-side/high-side)	At maximum gain		+33/+41		dBm
IIP3	At maximum gain		-16		
	At minimum gain		+26		
1-dB compression point	Maximum gain		-30		dBm
	Minimum gain		+8		
ADC dynamic range	10-kHz bandwidth		90		dB
	1-MHz bandwidth		66		
	2-MHz bandwidth		60		
Cascaded receive gain	Maximum gain		43		dB
	Minimum gain		-43		
Cascaded gain accuracy			$\pm 1$		dB
Cascaded receive gain step size			3		dB

## Receive Parameters (continued)

$T_A = 25^\circ\text{C}$ ,  $V_{DD} = 3.3\text{ V}$ ,  $f_c = 915\text{ MHz}$ ,  $f_{\text{xtal}} = 40\text{ MHz}$  if nothing else stated

PARAMETER	CONDITION	MIN	TYP	MAX	UNIT
RX differential input impedance	At maximum gain		51 – j13		$\Omega$
RX I/Q data sample rate: Maximum supported sample rate	The sample rate is configurable: $F_{\text{SR}} = \frac{F_{\text{XTAL}}}{M \times N}$		5		MHz
Minimum supported sample rate	where $M \in [4, 64]$ and $N = 2$ or 4, and are both integers		0.16		
Digital filter bandwidth	The digital filters are programmable (for more information, see <a href="#">Section 5.3, Receiver</a> ).	See <a href="#">Section 5.3, Receiver</a> .			MHz
Anti-aliasing filter (AAF) –3-dB bandwidth (two-sided)	The filters can be approximated as second-order Butterworth.				
Bandwidth setting 0b11			3.4		MHz
Bandwidth setting 0b10			1.5		
Bandwidth setting 0b01			1.0		
Bandwidth setting 0b00			0.6		

## 4.8 Transmit Parameters

$T_A = 25^\circ\text{C}$ ,  $V_{DD} = 3.3\text{ V}$ ,  $f_c = 915\text{ MHz}$ ,  $f_{\text{xtal}} = 40\text{ MHz}$  if nothing else stated

PARAMETER	CONDITION	MIN	TYP	MAX	UNIT
Maximum output power	TI recommends using the low-IF configuration if the CC1260 device outputs more than +3 dBm.		+13		dBm
Maximum (average) output power, OFDM	Assuming 10-dB peak-to-average ratio		+3		dBm
1-dB compression point	At maximum output power setting		+12		dBm
Minimum average output power	Assuming 10-dB peak-to-average ratio		–32		dBm
Output power step size	Using gain control only		3		dB
	Using both gain control and digital adjustment in TX digital-to-analog converters (DACs) to reduce output power		< 0.1		dB
Transmit $EVM_{\text{RMS}}$ : Zero IF transmitter configuration, with calibration	Measured using OFDM 802.15.4g option 3 MCS level 6, transmitted at +3 dBm		–29		dB
Zero IF transmitter configuration, without calibration			–25		

**Transmit Parameters (continued)**
 $T_A = 25^\circ\text{C}$ ,  $V_{DD} = 3.3\text{ V}$ ,  $f_c = 915\text{ MHz}$ ,  $f_{\text{xtal}} = 40\text{ MHz}$  if nothing else stated

PARAMETER	CONDITION	MIN	TYP	MAX	UNIT
TX spurious emissions/channel leakage power (excluding harmonics):					
Low IF transmitter configuration	Requires TX calibration				
> 1-MHz offset	Measured using OFDM		-29		
> 15-MHz offset	802.15.4g option 3 MCS level 6 transmitted at +3 dBm, sampled at 5 MHz over uPP interface		-71		
Zero IF transmitter configuration:					
0.4-MHz offset	Emissions are measured in 100-kHz bandwidth and presented in dBc relative to carrier power level.		-51		dBc
0.5-MHz offset			-60		
0.8-MHz offset	TI recommends using the low-IF configuration if the CC1260 device outputs more than +3 dBm.		-64		
$\geq 1.2$ -MHz offset			-66		
$\geq 2$ -MHz offset			-68		
$\geq 5.7$ -MHz offset, except spurs at $\pm 40$ MHz offset			-74		
			-71		
Harmonics:	Continuous wave transmitted at +3 dBm				
Second harmonic			-28		dBm
Third harmonic			-46		
Analog filter -3-dB bandwidth (two-sided):	The filters are programmable with a 4-bit range and can be approximated as 2nd order Butterworth.				
Maximum programmable bandwidth			20		MHz
Minimum programmable bandwidth			4.6		
Digital intermediate frequency (IF):					
Setting 0	The analog filter bandwidth should be adjusted according to the IF.		0		MHz
Setting 1			2.5		
Setting 2			5		
TX I/Q data sample rate:					
Maximum supported sample rate	The sample rate of the data sent to the CC1260 must be		10		MHz
Minimum supported sample rate	equal to: $F_{\text{SR}} = \frac{F_{\text{XTAL}}}{P}$ where $P \in [4, 128]$ and is an integer		0.3		
TXDAC clock frequency	The CC1260 device performs first-order upsampling of the I/Q data to the DAC clock frequency.		40		MHz
TX optimum load impedance	The differential load impedance that the CC1260 device must see for best performance		140+j95		$\Omega$
TX source impedance	The differential source impedance represented by the CC1260 device (at +10 dBm)		41-j291		$\Omega$

## 4.9 Frequency Synthesizer

$T_A = 25^\circ\text{C}$ ,  $V_{DD} = 3.3\text{ V}$ ,  $f_c = 915\text{ MHz}$ ,  $f_{\text{xtal}} = 40\text{ MHz}$  if nothing else stated

PARAMETER	CONDITION	MIN	TYP	MAX	UNIT
Frequency resolution			30		Hz
Phase noise	±10-kHz offset		-101		dBc/Hz
	±100-kHz offset		-102		dBc/Hz
	±1-MHz offset		-123		dBc/Hz

## 4.10 Wake-Up and Timing

$T_A = 25^\circ\text{C}$ ,  $V_{DD} = 3.3\text{ V}$ ,  $f_c = 915\text{ MHz}$ ,  $f_{\text{xtal}} = 40\text{ MHz}$  if nothing else stated

PARAMETER	CONDITION	MIN	TYP	MAX	UNIT
Powerdown to IDLE	Depends on crystal		0.2		ms
IDLE to RX	Excluding calibration time		122		μs
IDLE to TX	Excluding calibration time		122		μs
RX/TX turnaround	Excluding calibration time		40		μs
PLL calibration			0.2		ms
RX AGC gain control settling time, at maximum bandwidth	Settling within 0.1% of final value, excluding propagation delay through digital RX filters.		2		μs
Propagation delay through RX digital filters. At maximum bandwidth ( $M = 4$ ) and maximum FIR length.	Delay in seconds given by: $\text{Delay} = M \times \frac{\text{FIR\_LENGTH} + 12}{2 \times F_{\text{XTAL}}}$ where $M \in [4, 64]$ and is identical to the RX sample rate $M$ , and FIR_LENGTH is 29, 57, or 85		5		μs
SPI interface SCLK maximum read access frequency			10		MHz
SPI interface SCLK maximum write access frequency			10		MHz

## 4.11 Crystal Oscillator

$T_A = 25^\circ\text{C}$ ,  $V_{DD} = 3.3\text{ V}$

PARAMETER	CONDITION	MIN	TYP	MAX	UNIT
Crystal frequency	A significant increase in noise figure at multiples of the crystal frequency is expected.	38.4		40	MHz
Load capacitance ( $C_L$ )			10		pF
ESR	Simulated over operating conditions			60	Ω

## 4.12 Clock Output

 $T_A = 25^\circ\text{C}$ ,  $V_{DD} = 3.3\text{ V}$ 

PARAMETER	CONDITION	MIN	TYP	MAX	UNIT
Clock output frequency	A significant increase in noise figure at multiples of the clock output frequency is expected.		XOSC/2		MHz
Output high voltage	Assuming a load capacitance of 15 pF or less	$0.8 \times V_{dd}$			V
Output low voltage				$0.2 \times V_{dd}$	V
Integrated jitter, from 1 kHz			1		ps

## 4.13 Clock Input (TCXO)

 $T_A = 25^\circ\text{C}$ ,  $V_{DD} = 3.3\text{ V}$  if nothing else stated

PARAMETER	CONDITION	MIN	TYP	MAX	UNIT
Clock frequency		38.4		40	MHz
Clock input amplitude (peak-to-peak) <sup>(1)</sup>	Must not exceed supply voltage. Signal must be AC-coupled. The recommended value is 18 pF.	0.8		$V_{DD}$	V
Clock source phase noise: ± 10-kHz offset ± 100-kHz offset	Required to avoid degradation of CC1260 phase noise		<-140 <-145		dBc/Hz
Input capacitance			1.5		pF

(1) Simulated over operating conditions

## 4.14 General I/O (GPIO, SPI, and RESET\_N Pin)

 $T_A = 25^\circ\text{C}$ ,  $V_{DD} = 3.3\text{ V}$ 

PARAMETER	CONDITION	MIN	TYP	MAX	UNIT
Logic input high voltage		$0.8 \times V_{DD}$			V
Logic input low voltage				$0.2 \times V_{DD}$	V
Logic output high voltage		$0.8 \times V_{DD}$			V
Logic output low voltage				$0.2 \times V_{DD}$	V

## 4.15 uPP Interface

 $T_A = 25^\circ\text{C}$ ,  $V_{DD} = 3.3\text{ V}$ ,  $V_{DD}$  uPP interface = 1.8 V, assuming 5-pF load on pins when uPP interface outputs data

PARAMETER	CONDITION	MIN	u	Max	UNIT
uPP interface input high voltage			1.1		V
uPP interface input low voltage			0.7		V
uPP interface output high rise time	uPP interface uses slew-rate limited drivers to minimize disturbance in RX. <sup>(1)</sup>		11		ns
uPP interface output low fall time			11		ns
uPP interface output clock rate	Data sampled on both edges of clock			10	MHz
uPP interface input clock rate	Data sampled on both edges of clock			20	MHz

(1) The rise and fall time is specified from 0.3 to 1.5 V, assuming a 5-pF load and maximum configured I/O drive strength.

## 4.16 Temperature Sensor

VDD = 3.3 V

PARAMETER	CONDITION	MIN	TYP	MAX	UNIT
Temperature sensor accuracy:					
Calibrated <sup>(1)</sup>			5		°C
Uncalibrated			26		
Temperature sensor range		–40		105	°C
Output slope			103		ADC samples/°C

(1) Requires initial offset to be measured at room temperature and subtracted from measurements

## 4.17 Voltage Sensor

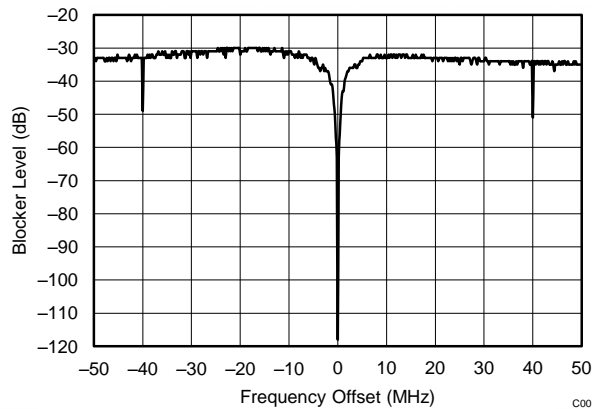
T<sub>A</sub> = 25°C

PARAMETER	CONDITION	MIN	TYP	MAX	UNIT
Voltage sensor accuracy:					
Calibrated <sup>(1)</sup>			12		mV
Uncalibrated			300		
Voltage sensor range		2.3		3.6	V
Output slope			15		ADC samples/mV

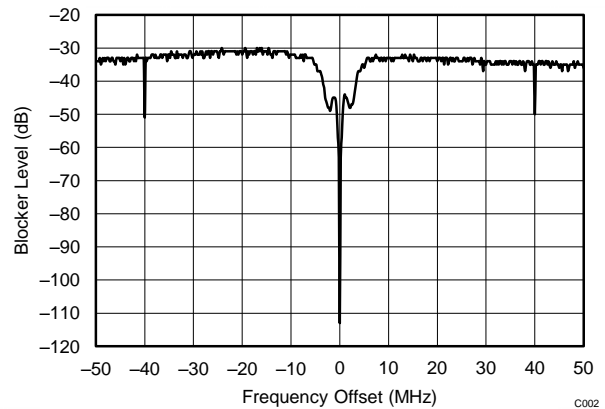
(1) Requires initial offset to be measured at 3.3 V and subtracted from measurements

### 4.18 Typical Characteristics

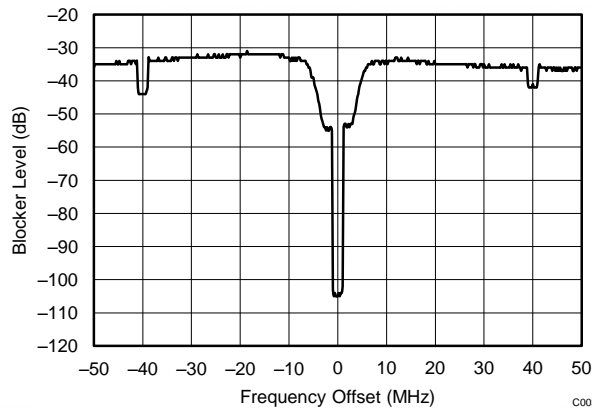
$T_A = 25^\circ\text{C}$ ,  $V_{DD} = 3.3\text{ V}$ ,  $f_c = 915\text{ MHz}$ ,  $f_{\text{xtal}} = 40\text{ MHz}$



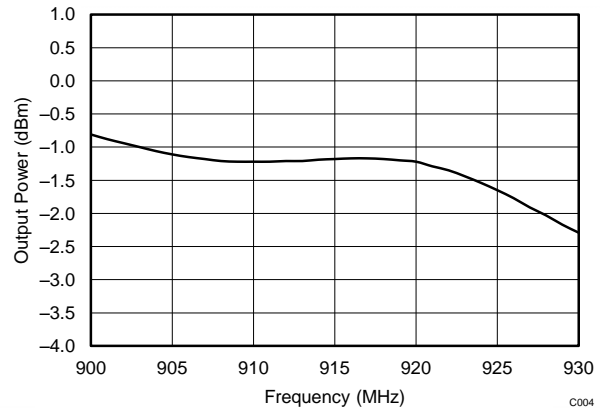
**Figure 4-1. Blocker Desensitization (200-kHz BW) with Minimum AAF Bandwidth. Blocker Level at Which the Noise Figure Increases by 3 dB**



**Figure 4-2. Blocker Desensitization (200-kHz BW) with Maximum AAF Bandwidth. Blocker Level at Which the Noise Figure Increases by 3 dB**

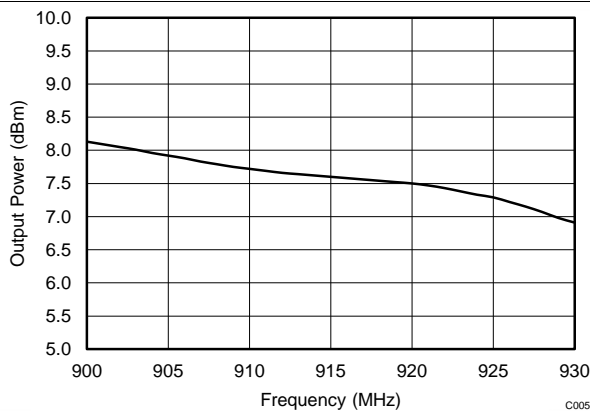


**Figure 4-3. Blocker Desensitization (2-MHz BW) with Maximum AAF Bandwidth. Blocker Level at Which the Noise Figure Increases by 3 dB**



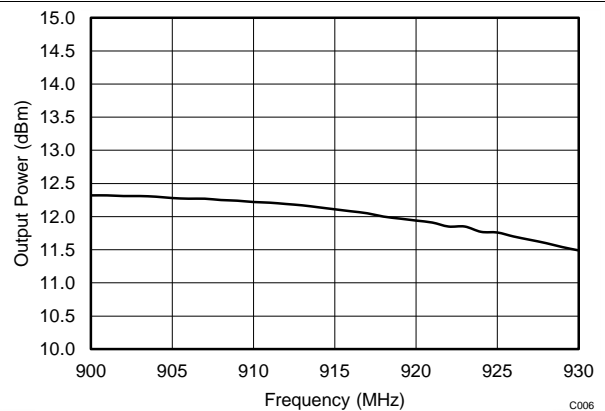
PA Setting = 0x36

**Figure 4-4. TX Output Power vs Frequency**



PA Setting = 0x76

**Figure 4-5. TX Output Power vs Frequency**

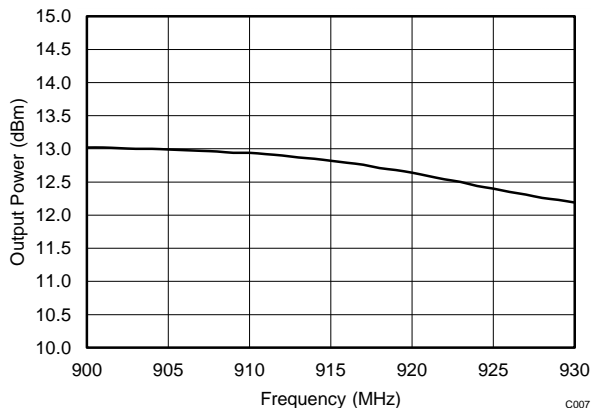


PA Setting = 0xB6

**Figure 4-6. TX Output Power vs Frequency**

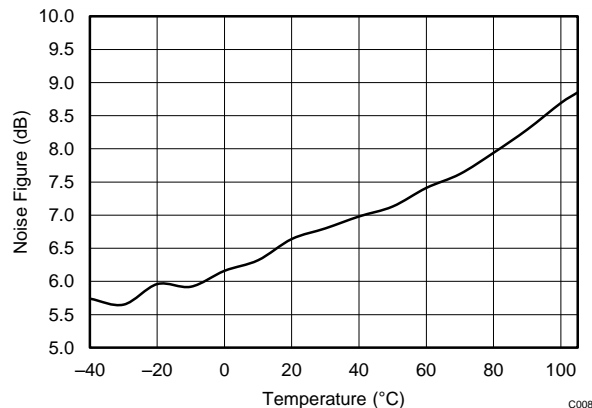
**Typical Characteristics (continued)**

$T_A = 25^\circ\text{C}$ ,  $V_{DD} = 3.3\text{ V}$ ,  $f_c = 915\text{ MHz}$ ,  $f_{\text{xtal}} = 40\text{ MHz}$

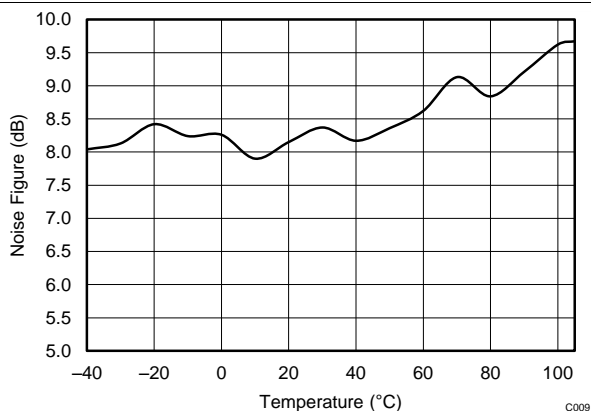


PA Setting = 0xBF

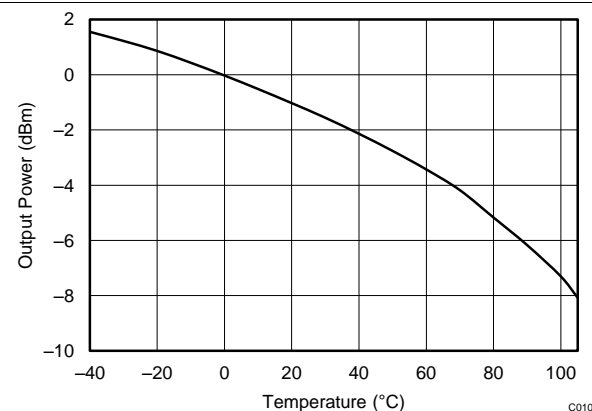
**Figure 4-7. TX Maximum Output Power vs Frequency**



**Figure 4-8. Noise Figure with 2-MHz Bandwidth vs Temperature**

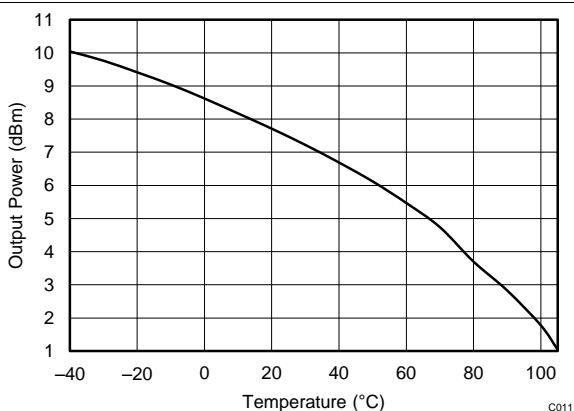


**Figure 4-9. Noise Figure with 200-kHz Bandwidth vs Temperature**



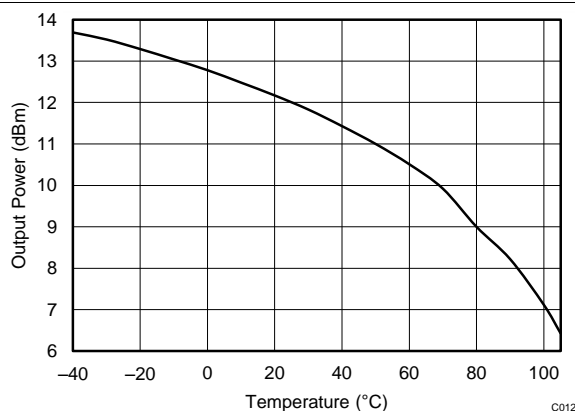
PA Setting = 0x36

**Figure 4-10. TX Output Power vs Temperature**



PA Setting = 0x76

**Figure 4-11. TX Output Power vs Temperature**



PA Setting = 0xB6

**Figure 4-12. TX Output Power vs Temperature**

Typical Characteristics (continued)

$T_A = 25^\circ\text{C}$ ,  $V_{DD} = 3.3\text{ V}$ ,  $f_c = 915\text{ MHz}$ ,  $f_{\text{xtal}} = 40\text{ MHz}$

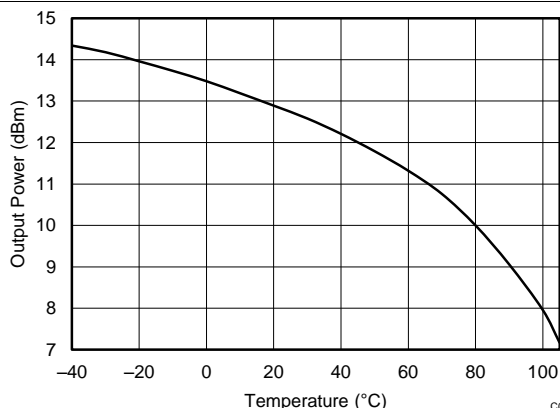


Figure 4-13. TX Output Power vs Temperature (Maximum CW Output Power) C013

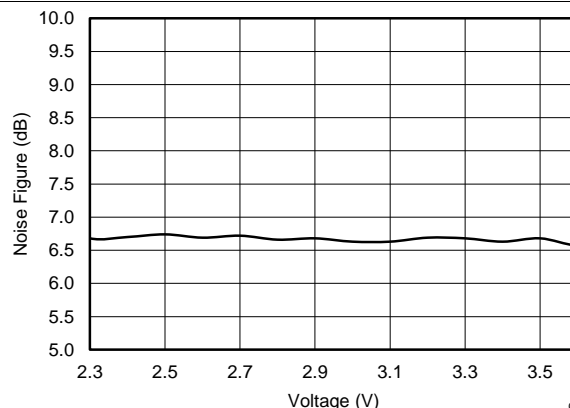


Figure 4-14. Noise Figure with 2-MHz Bandwidth vs Voltage C014

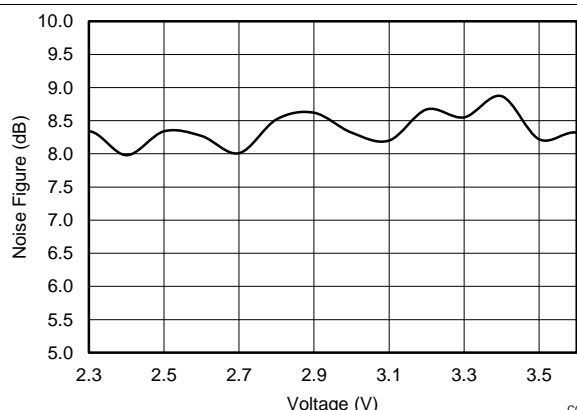
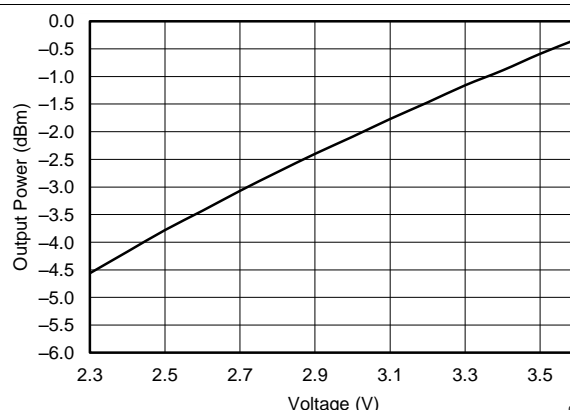
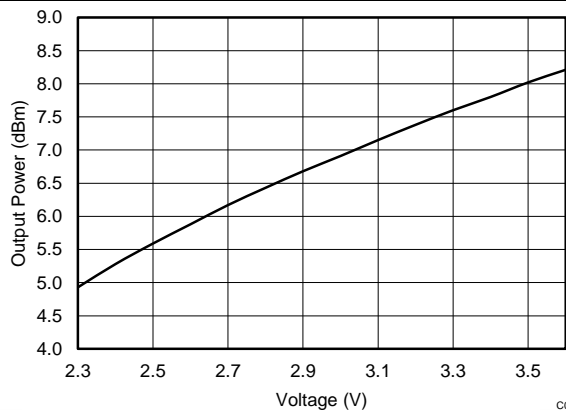


Figure 4-15. Noise Figure with 200-kHz Bandwidth vs Voltage C015



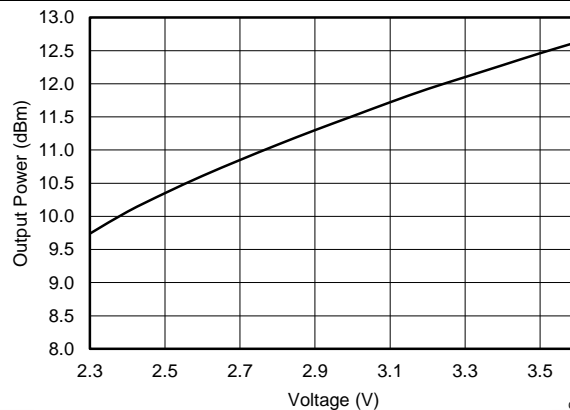
PA Setting = 0x36

Figure 4-16. TX Output Power vs Voltage C016



PA Setting = 0x76

Figure 4-17. TX Output Power vs Voltage C017

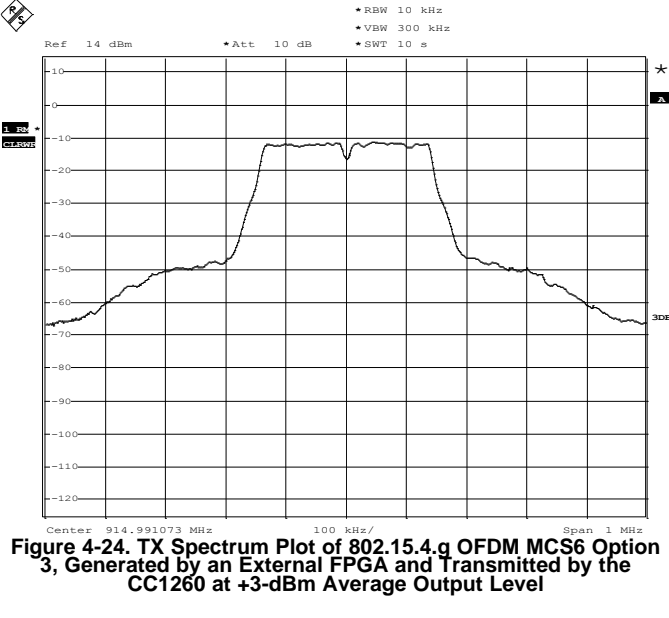
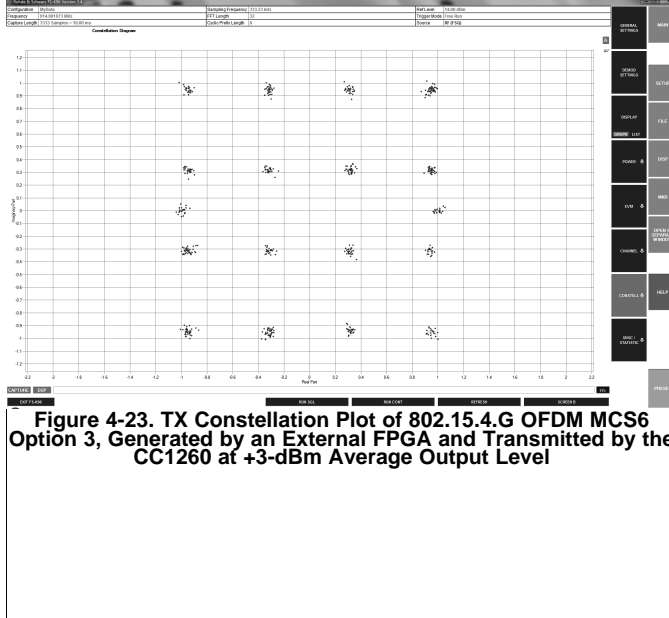
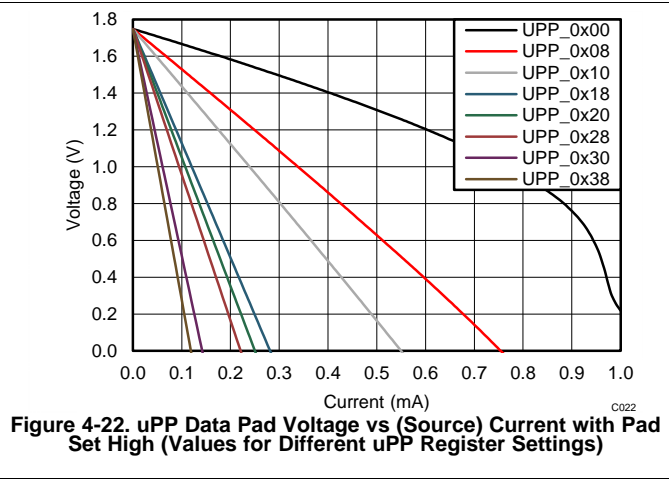
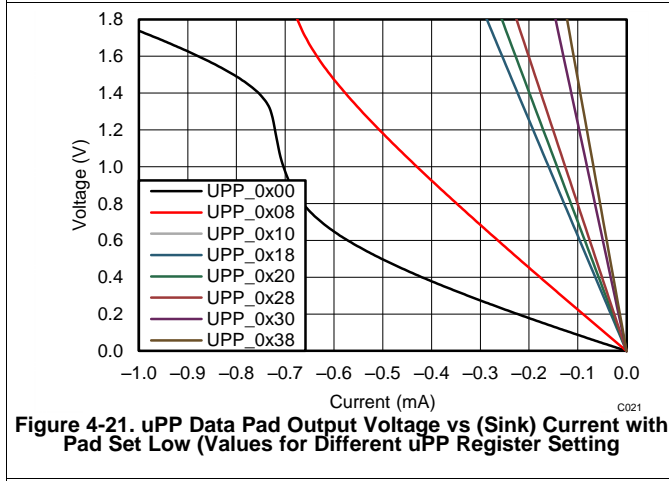
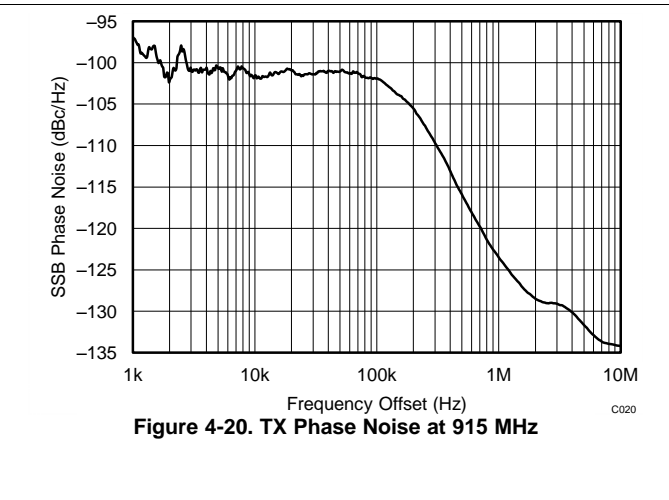
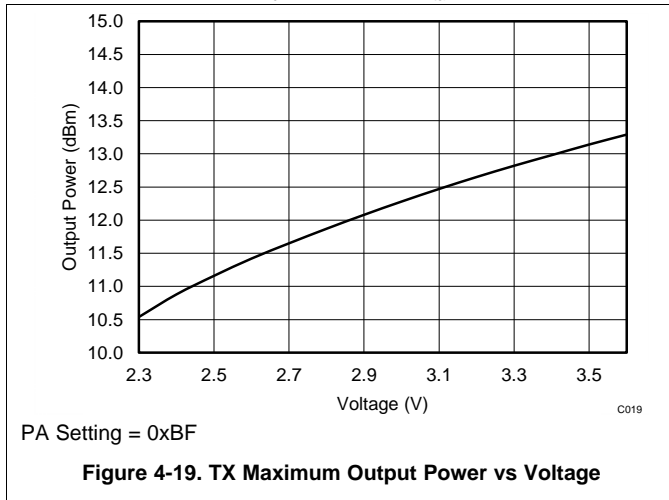


PA Setting = 0xB6

Figure 4-18. TX Output Power vs Voltage C018

Typical Characteristics (continued)

$T_A = 25^\circ\text{C}$ ,  $V_{DD} = 3.3\text{ V}$ ,  $f_c = 915\text{ MHz}$ ,  $f_{\text{xtal}} = 40\text{ MHz}$



## 5 Detailed Description

### 5.1 Functional Block Diagram

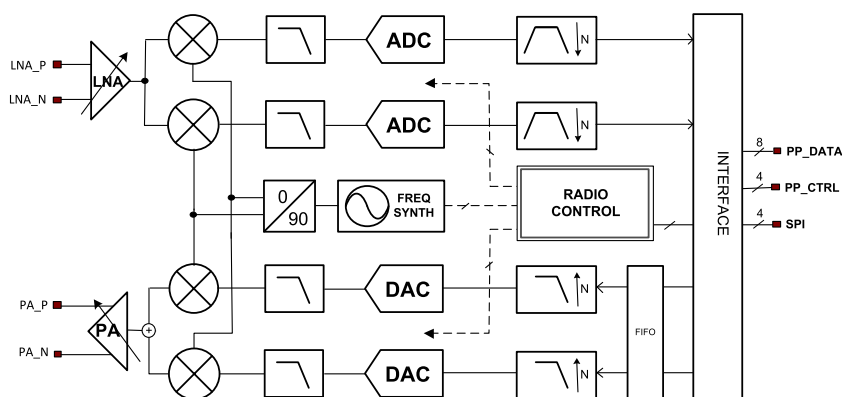


Figure 5-1. CC1260 Functional Block Diagram

### 5.2 Frequency Synthesizer

At the heart of CC1260 device is a fully integrated, fractional-N, ultra-high performance frequency synthesizer. The frequency synthesizer is designed for excellent phase noise performance, giving very high selectivity and blocking performance. The system is designed to comply with the most stringent regulatory spectral masks at maximum transmit power. A crystal can be connected to XOSC\_Q1 and XOSC\_Q2, or a TCXO can be connected to the external clock input. The oscillator generates the reference frequency for the synthesizer, as well as clocks for the analog-to-digital converters (ADCs) and the digital part. If a TCXO is used, the CC1260 device automatically turns the TCXO on and off when required to support low-power modes. The CC1260 device provides an optional clock output that can be used as the clock reference for the DSP. The optional clock signal is derived from the main reference clock on the CC1260 device.

### 5.3 Receiver

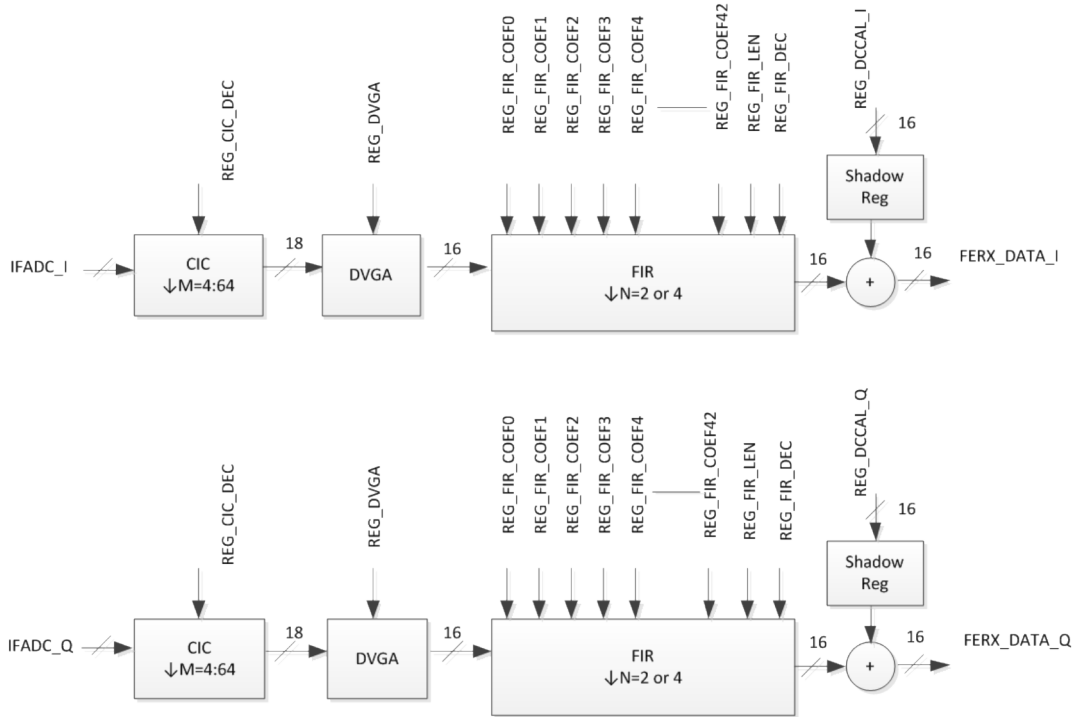
The CC1260 device features a high-performance direct-conversion receiver with programmable high-order digital filters. The received RF signal is amplified by the low-noise amplifier (LNA), down-converted in quadrature, filtered, and the I/Q signals are digitized by the high dynamic range ADCs. Automatic gain control (AGC) and RSSI functions are shared between the CC1260 device and the DSP.

#### 5.3.1 Receiver Decimation and Filtering

To remove blockers and ADC quantization noise, the CC1260 device performs decimation and filtering of the received signal in two steps:

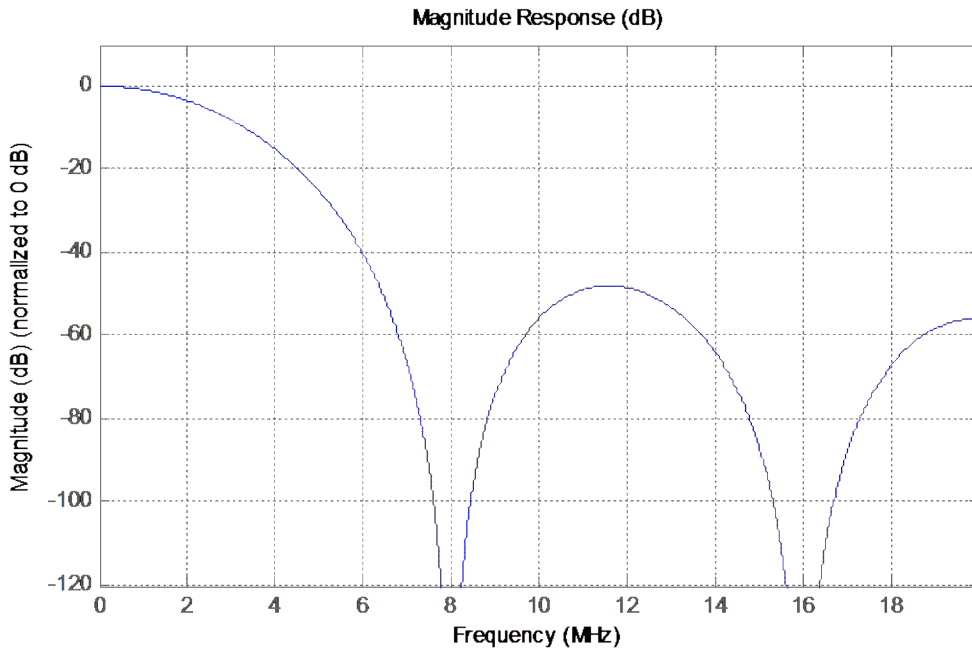
1. The signal passes through a programmable CIC decimation filter.
2. Additional filtering occurs in a programmable FIR filter (see [Figure 5-2](#)).

In the second step, the sample rate is decimated by a factor of 2 or 4. [Section 4](#), *Specifications*, includes formulas for calculating the sample rate.



**Figure 5-2. RX Digital Signal Processing**

Figure 5-3 shows the CIC filter characteristics decimated by 5.



**Figure 5-3. CIC Filter Characteristic Decimated by 5 (One-Sided)**

### 5.3.2 Programmable FIR Filter

The FIR filters are programmable filters with odd length and even symmetry, and are implemented as polyphase filters with the option to decimate by either 2 or 4. The filter length is configurable as either 29, 57, or 85. The sum of the coefficients must be normalized, that is, the sum of the coefficients must be equal to 215 because the signal is represented as 16-bit signed.

### 5.3.3 DC Offset Correction

The CC1260 device includes hardware support for subtraction of DC error on I and Q. The subtraction value is stored in a shadow register, which allows byte-wise updating of DC calibration values and simultaneous enabling of all values using the SPI. The DC correction values are enabled when writing to the low byte of the DC calibration registers (for more information, see [Section 6.2.4, RX Calibration](#)).

## 5.4 Transmitter

The I/Q RF front end of the CC1260 device employs a linear quadrature up-conversion topology. The modulated I and Q data are passed from the DSP (or equivalent implementation) to the CC1260 device using a parallel interface tailored to fit seamlessly with TI DSPs, and then are upsampled to the system clock through first-order interpolation. The CC1260 transmitter, which comprises quadrature DACs, smoothing filters, an I/Q modulator, and a power amplifier (PA), converts the baseband data to the appropriate RF channel of operation. The output power is programmable with a fine step to enable accurate network power optimization.

Figure 5-4 shows a block diagram of the TX digital processing.

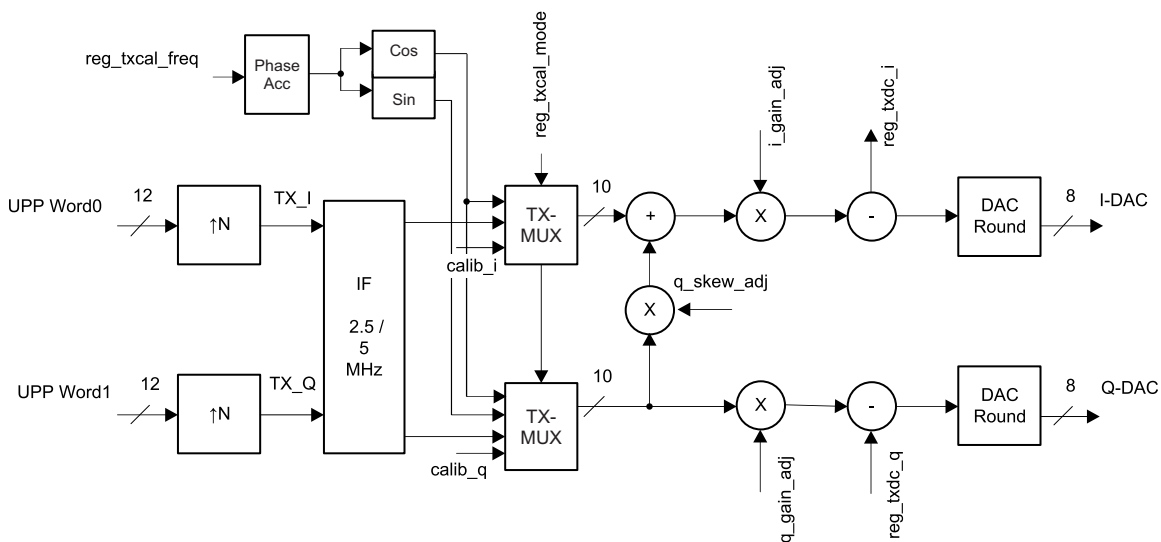


Figure 5-4. TX Digital Processing

### 5.4.1 Intermediate Frequency (Low IF, Zero IF)

The CC1260 device supports a transmitter intermediate frequency of 0,  $\pm 2.5$ , and  $\pm 5$  MHz. Using an IF means that spurious emissions and noise due to transmitter non-idealities, such as I/Q mismatch, are pushed outside the signal bandwidth, resulting in improved EVM at the cost of increased power leak at the adjacent channel.

For the best EVM, using an IF (of either  $\pm 2.5$  MHz or  $\pm 5$  MHz) is recommended (and is referred to as *low IF*); applications that must meet strict spectral masks should use zero IF. The low-IF topology, which is less sensitive to injection pulling of the internal VCO by the PA, is recommended for systems targeting high-transmit output power from the CC1260 device.

## 5.4.2 Upsampling

Data sent to the CC1260 device through the uPP interface is upsampled from the uPP rate to the TX DAC clock frequency using a first-order Farrow interpolator (see [Figure 5-5](#)). Only integer upsampling rates are supported.

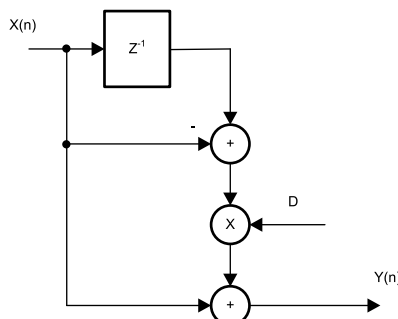


Figure 5-5. TX Upsampler

## 5.4.3 I/Q Correction

The CC1260 device includes hardware support for estimation and correction of the I/Q phase and gain mismatch and DC offset in the transmitter (for more information, see [Section 6.2.2, TX Calibration of I/Q Mismatch and DC Offset](#)).

## 5.5 Radio Control and User Interface

The CC1260 digital control system is built around the main radio control (MARC), which handles power modes and radio sequencing. A 4-wire protocol viewer serial interface is used for configuration.

### 5.5.1 Device States and Power Modes

The CC1260 device supports power modes in addition to the RX and TX modes:

- **POWERDOWN:** POWERDOWN has the lowest power consumption, longest start-up time, and no access to registers.
- **XOFF:** XOFF offers quicker start-up times but uses more current.
- **IDLE:** The radio is disabled. The clock is still running, registers can be accessed, strobe commands can be sent, and the external clock output is available. IDLE allows quick transition to RX or TX.
- **TX\_CAL:** Allows access to dedicated system hardware which enables calibration of device imbalances and offsets

The optional clock output is always available unless the device is in POWERDOWN or XOFF mode. SPI commands provide transition between the different device states.

[Figure 5-6](#) shows a simplified state diagram.

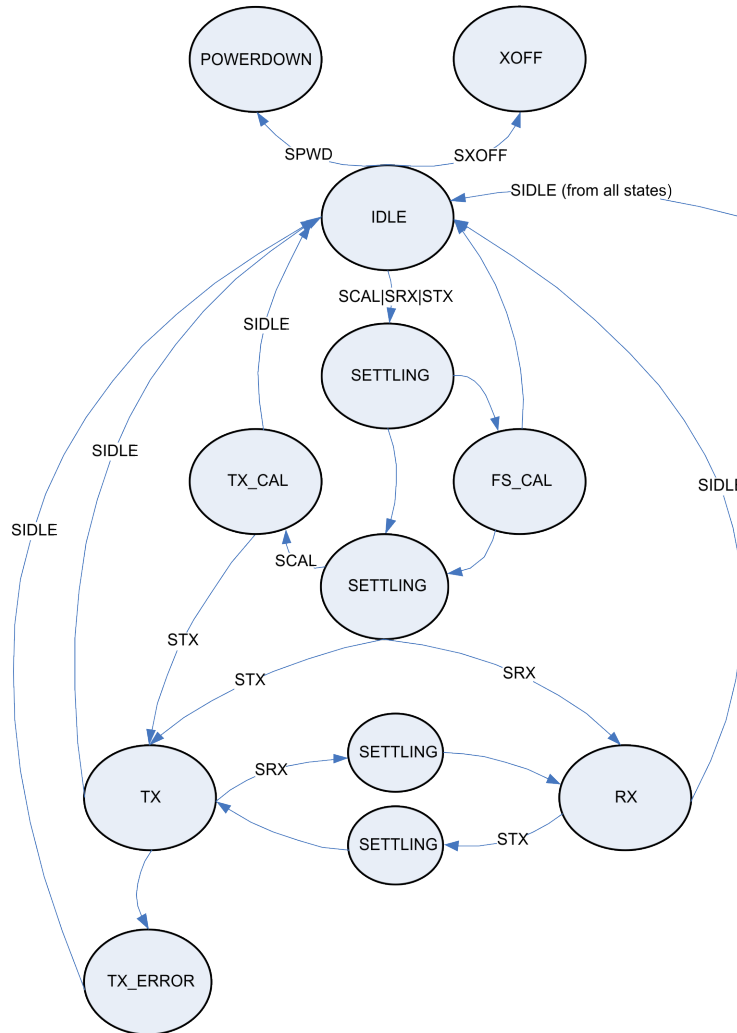


Figure 5-6. Simplified State Diagram

### 5.5.2 uPP Interface

The uPP interface is a source-synchronous parallel interface that transmits or receives (when the CC1260 device is in RX or TX, respectively) a continuous stream of words using both edges of the clock (DCLK). The 8-bit words are formatted into 4-word frames that encapsulate one complex 16-bit sample. DSTART indicates the start of each frame.

To minimize switching noise, all output lines (including the clock line) are slew-rate limited when the CC1260 device is in RX.

To avoid overflows when the CC1260 device is in TX, a 32-byte TX data FIFO is implemented and the DWAIT flow control signal indicates to the baseband processor that no data will be accepted in the following clock cycle. DWAIT is ignored when the CC1260 device is in RX.

The device enters the TX\_ERROR state if the uPP interface is not handled correctly during TX.

Figure 5-7 and Figure 5-8 show the RX and TX data parallel interface waveforms, respectively.

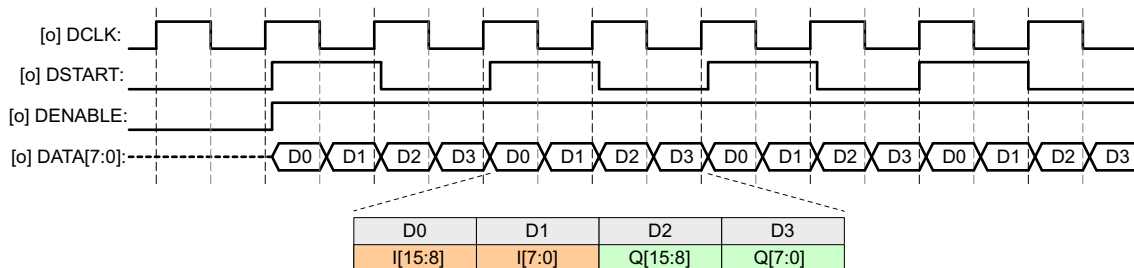


Figure 5-7. RX Data Parallel Interface Waveform

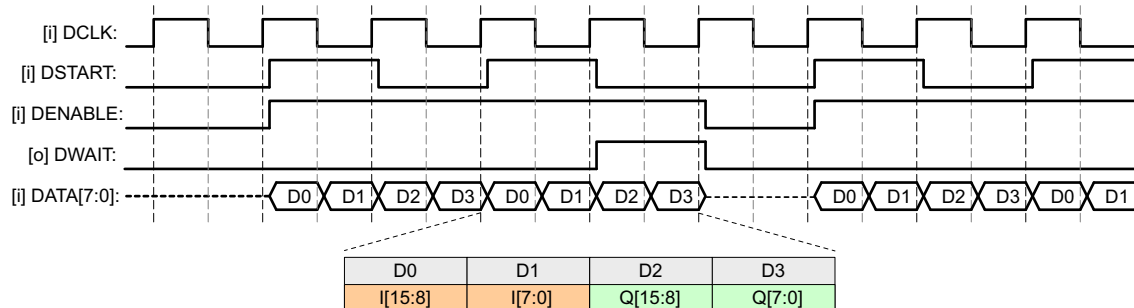


Figure 5-8. TX Data Parallel Interface Waveform

### 5.5.3 SPI Radio Control Interface

A 4-wire SPI slave interface allows access to internal hardware registers and allows posting of commands to the radio control state machine that controls the operating state of the device (see [Figure 5-6](#)).

## 6 Applications, Implementation, and Layout

### 6.1 Typical Application

Figure 6-1 shows a typical application circuit using the CC1260 device as a single-chip radio transceiver.

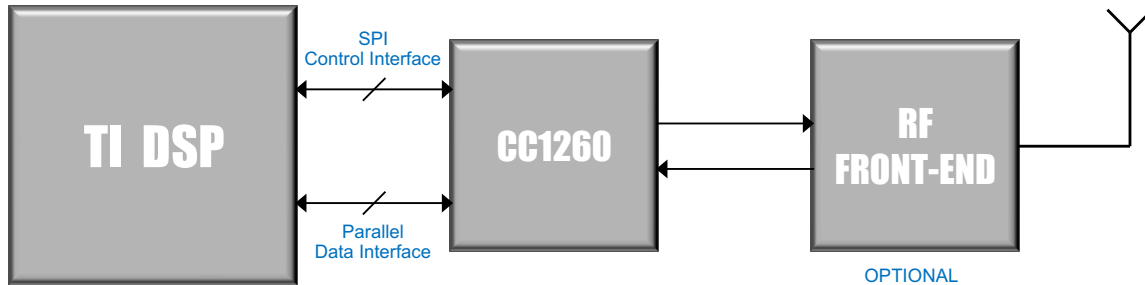


Figure 6-1. Typical Application Circuit Using CC1260 Device as a Single-Chip Radio Transceiver

### 6.2 Calibration

The CC1260 device includes hardware support for device calibration.

The calibration is split into four categories:

- Synthesizer calibration (see Section 6.2.1, *PLL Calibration (FS\_CAL)*)
- TX calibration (see Section 6.2.2, *TX Calibration of I/Q Mismatch and DC Offset*)
- PA gain calibration (see Section 6.2.3, *PA Gain Calibration*)
- RX calibration (see Section 6.2.4, *RX Calibration*)

The synthesizer calibration steps are performed automatically when entering RX or TX, unless the device is configured to do otherwise. TX and RX calibration must be performed manually.

#### 6.2.1 PLL Calibration (FS\_CAL)

Calibration of the synthesizer must meet the specified frequency accuracy and phase noise. Nevertheless, if a calibration has been performed recently and a significant change in frequency is not required, calibration of the synthesizer can be skipped to save time and power consumption.

The CC1260 device can be configured to perform the PLL calibration automatically before entering TX or RX.

#### 6.2.2 TX Calibration of I/Q Mismatch and DC Offset

TX calibration can be performed with the assistance of dedicated hardware included on the CC1260 device. This hardware enables accurate measurement of gain and phase imbalance as well as LO leakage, made on the fly without requiring RF measurement equipment.

#### 6.2.3 PA Gain Calibration

In addition to TX I/Q mismatch and DC offset calibration, gain calibration must be performed to meet EVM specifications and to reduce variation in output power. An initial calibration is required to remove differences from part to part, as well as to make adjustments due to temperature and voltage changes.

The initial gain calibration must use an external RF power detector or similar equipment. To make adjustments due to temperature and voltage changes, the temperature and voltage sensors included on the CC1260 device, or elsewhere in the system, can be used.

## 6.2.4 RX Calibration

RX calibration of the DC offset present in the device is required for applications sensitive to low-frequency noise. Because this offset varies slowly over time, an RX calibration should be performed before entering RX to derive the best possible noise figure. External RF equipment is not required for the RX calibration.

# 7 Device and Documentation Support

## 7.1 Community Resources

The following links connect to TI community resources. Linked contents are provided "AS IS" by the respective contributors. They do not constitute TI specifications and do not necessarily reflect TI's views; see TI's [Terms of Use](#).

[TI E2E™ Online Community](#) *TI's Engineer-to-Engineer (E2E) Community*. Created to foster collaboration among engineers. At [e2e.ti.com](#), you can ask questions, share knowledge, explore ideas and help solve problems with fellow engineers.

[TI Embedded Processors Wiki](#) *Texas Instruments Embedded Processors Wiki*. Established to help developers get started with Embedded Processors from Texas Instruments and to foster innovation and growth of general knowledge about the hardware and software surrounding these devices.

## 7.2 Trademarks

E2E is a trademark of Texas Instruments.

All other trademarks are the property of their respective owners.

## 7.3 Electrostatic Discharge Caution



This integrated circuit can be damaged by ESD. Texas Instruments recommends that all integrated circuits be handled with appropriate precautions. Failure to observe proper handling and installation procedures can cause damage.

ESD damage can range from subtle performance degradation to complete device failure. Precision integrated circuits may be more susceptible to damage because very small parametric changes could cause the device not to meet its published specifications.

## 7.4 Glossary

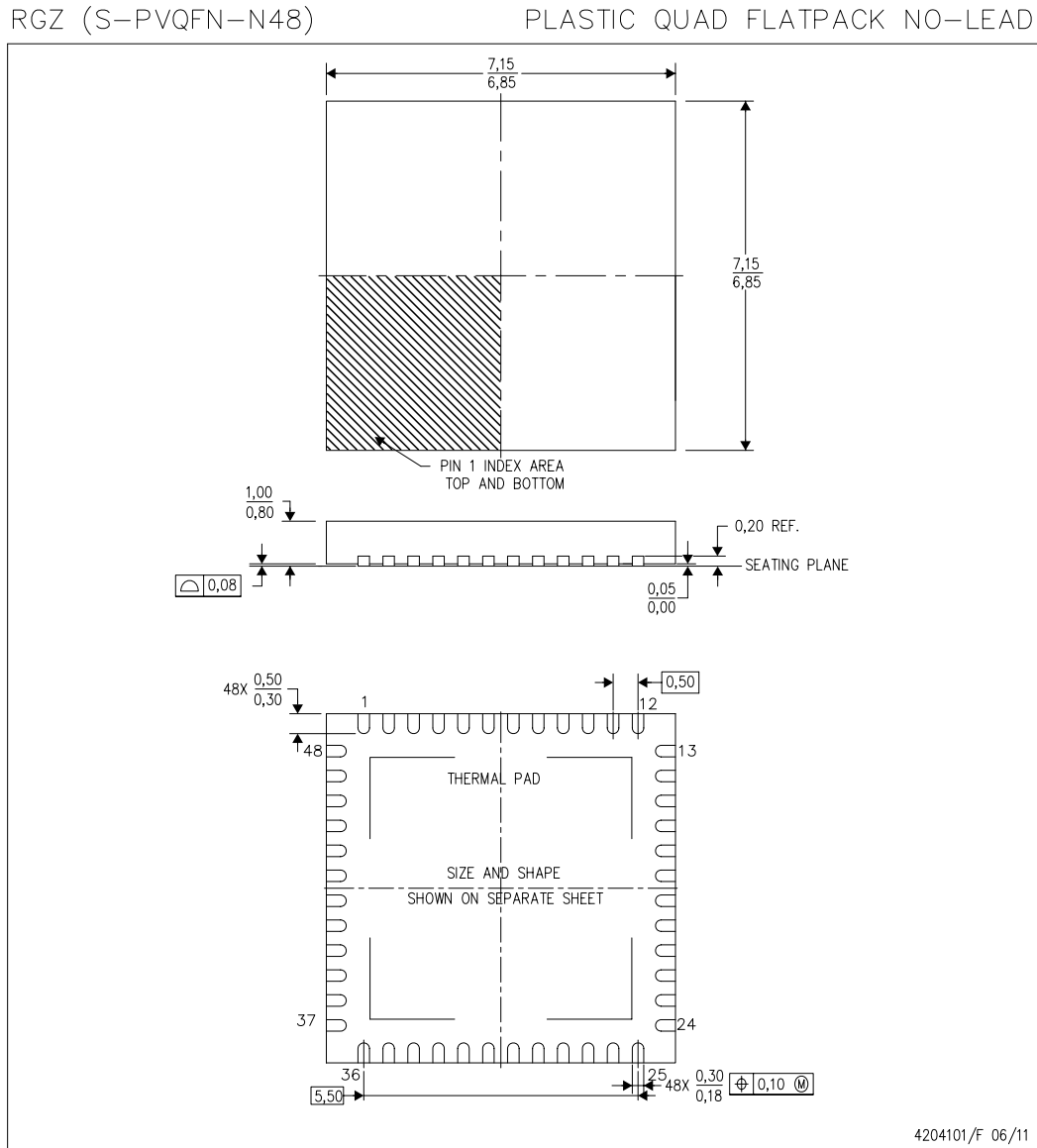
[SLYZ022](#) — *TI Glossary*.

This glossary lists and explains terms, acronyms, and definitions.

## 8 Mechanical Packaging and Orderable Information

This section contains mechanical packaging and orderable information. This information is the most current data available for the designated devices. This data is subject to change without notice and revision of this document. For browser-based versions of this data sheet, see the left-hand navigation.

### 8.1 VQFN Mechanical Data



- NOTES:
- A. All linear dimensions are in millimeters. Dimensioning and tolerancing per ASME Y14.5M-1994.
  - B. This drawing is subject to change without notice.
  - C. Quad Flatpack, No-leads (QFN) package configuration.
  - D. The package thermal pad must be soldered to the board for thermal and mechanical performance.
  - E. See the additional figure in the Product Data Sheet for details regarding the exposed thermal pad features and dimensions.
  - F. Falls within JEDEC MO-220.

RGZ (S-PVQFN-N48)

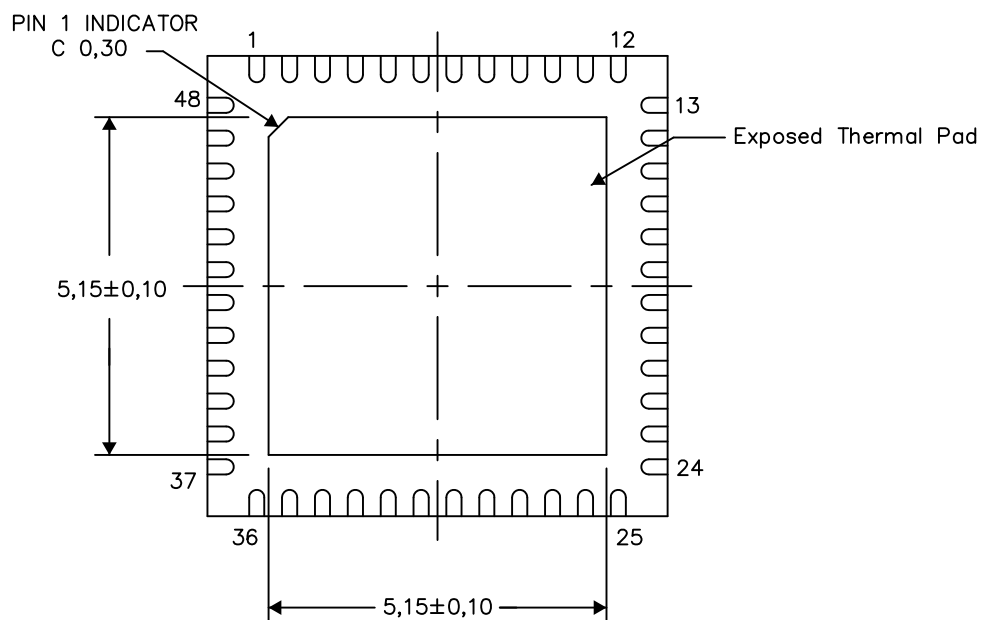
PLASTIC QUAD FLATPACK NO-LEAD

THERMAL INFORMATION

This package incorporates an exposed thermal pad that is designed to be attached directly to an external heatsink. The thermal pad must be soldered directly to the printed circuit board (PCB). After soldering, the PCB can be used as a heatsink. In addition, through the use of thermal vias, the thermal pad can be attached directly to the appropriate copper plane shown in the electrical schematic for the device, or alternatively, can be attached to a special heatsink structure designed into the PCB. This design optimizes the heat transfer from the integrated circuit (IC).

For information on the Quad Flatpack No-Lead (QFN) package and its advantages, refer to Application Report, QFN/SON PCB Attachment, Texas Instruments Literature No. SLUA271. This document is available at [www.ti.com](http://www.ti.com).

The exposed thermal pad dimensions for this package are shown in the following illustration.



Bottom View

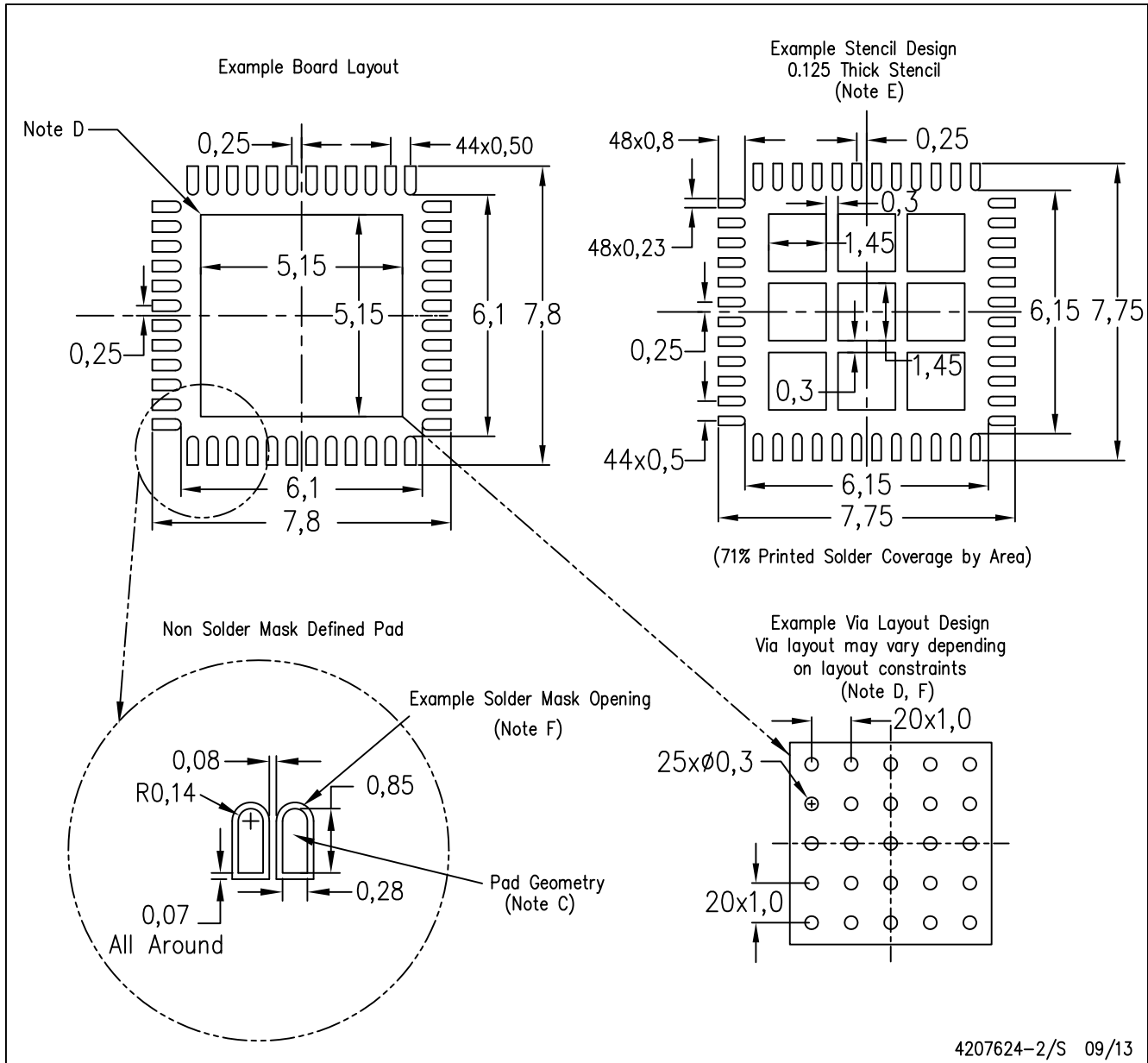
Exposed Thermal Pad Dimensions

4206354-2/X 01/14

NOTE: All linear dimensions are in millimeters

RGZ (S-PVQFN-N48)

PLASTIC QUAD FLATPACK NO-LEAD



- NOTES:
- All linear dimensions are in millimeters.
  - This drawing is subject to change without notice.
  - Publication IPC-7351 is recommended for alternate designs.
  - This package is designed to be soldered to a thermal pad on the board. Refer to Application Note, Quad Flat-Pack Packages, Texas Instruments Literature No. SLUA271, and also the Product Data Sheets for specific thermal information, via requirements, and recommended board layout. These documents are available at [www.ti.com](http://www.ti.com) <<http://www.ti.com>>.
  - Laser cutting apertures with trapezoidal walls and also rounding corners will offer better paste release. Customers should contact their board assembly site for stencil design recommendations. Refer to IPC 7525 for stencil design considerations.
  - Customers should contact their board fabrication site for recommended solder mask tolerances and via tenting recommendations for vias placed in the thermal pad.

## 8.2 Tape and Reel Dimensions

Figure 8-1 shows the tape and reel dimensions.

### TAPE AND REEL INFORMATION

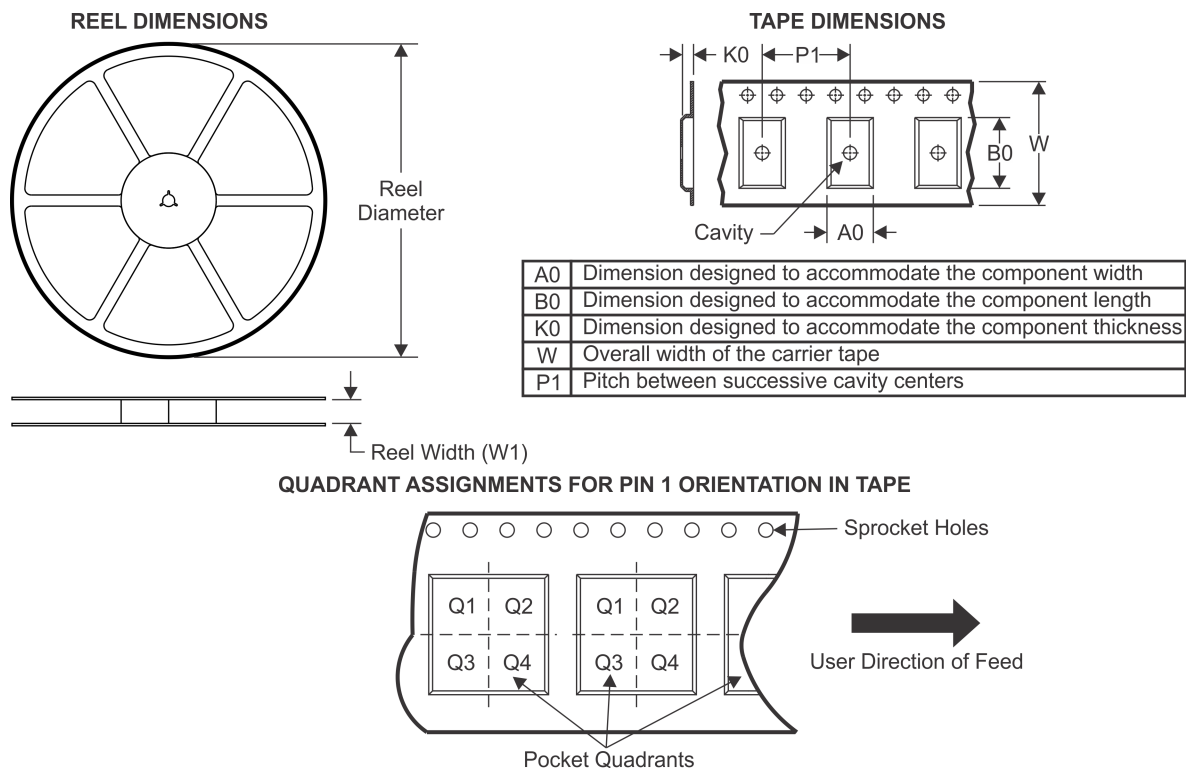


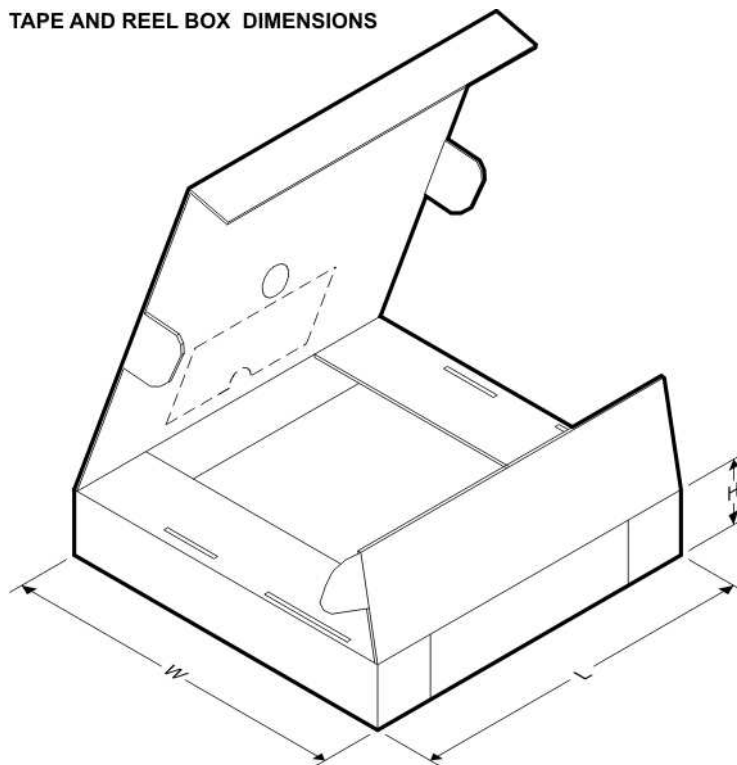
Figure 8-1. Tape and Reel Dimensions

Table 8-1 lists the measurements of the tape and reel dimensions.

Table 8-1. Tape and Reel Dimension Measurements

DEVICE	PKG.	PKG. DWG.	PINS	SPQ	REEL DIA. (mm)	REEL WIDTH W1 (mm)	A0 (mm)	B0 (mm)	K0 (mm)	P1 (mm)	W (mm)	PIN 1 QUAD.
CC1260RGZR	VQFN	RGZ	48	2500	330.0	16.4	7.3	7.3	1.5	12.0	16.0	Q2
CC1260RGZT	VQFN	RGZ	48	250	180.0	16.4	7.3	7.3	1.5	12.0	16.0	Q2

Figure 8-2 shows the dimensions of the tape and reel box.



**Figure 8-2. Tape and Reel Box Dimensions**

Table 8-2 lists the measurements of the tape and reel box dimensions.

**Table 8-2. Measurements of the Tape and Reel Box Dimensions<sup>(1)</sup>**

DEVICE	PACKAGE	PACKAGE DRAWING	PINS	SPQ	LENGTH (mm)	WIDTH (mm)	HEIGHT (mm)
CC1260RGZR	VQFN	RGZ	48	2500	336.6	336.6	28.6
CC1260RGZT	VQFN	RGZ	48	250	213.0	191.0	55.0

(1) All dimensions are nominal measurements.

## IMPORTANT NOTICE

Texas Instruments Incorporated and its subsidiaries (TI) reserve the right to make corrections, enhancements, improvements and other changes to its semiconductor products and services per JESD46, latest issue, and to discontinue any product or service per JESD48, latest issue. Buyers should obtain the latest relevant information before placing orders and should verify that such information is current and complete. All semiconductor products (also referred to herein as "components") are sold subject to TI's terms and conditions of sale supplied at the time of order acknowledgment.

TI warrants performance of its components to the specifications applicable at the time of sale, in accordance with the warranty in TI's terms and conditions of sale of semiconductor products. Testing and other quality control techniques are used to the extent TI deems necessary to support this warranty. Except where mandated by applicable law, testing of all parameters of each component is not necessarily performed.

TI assumes no liability for applications assistance or the design of Buyers' products. Buyers are responsible for their products and applications using TI components. To minimize the risks associated with Buyers' products and applications, Buyers should provide adequate design and operating safeguards.

TI does not warrant or represent that any license, either express or implied, is granted under any patent right, copyright, mask work right, or other intellectual property right relating to any combination, machine, or process in which TI components or services are used. Information published by TI regarding third-party products or services does not constitute a license to use such products or services or a warranty or endorsement thereof. Use of such information may require a license from a third party under the patents or other intellectual property of the third party, or a license from TI under the patents or other intellectual property of TI.

Reproduction of significant portions of TI information in TI data books or data sheets is permissible only if reproduction is without alteration and is accompanied by all associated warranties, conditions, limitations, and notices. TI is not responsible or liable for such altered documentation. Information of third parties may be subject to additional restrictions.

Resale of TI components or services with statements different from or beyond the parameters stated by TI for that component or service voids all express and any implied warranties for the associated TI component or service and is an unfair and deceptive business practice. TI is not responsible or liable for any such statements.

Buyer acknowledges and agrees that it is solely responsible for compliance with all legal, regulatory and safety-related requirements concerning its products, and any use of TI components in its applications, notwithstanding any applications-related information or support that may be provided by TI. Buyer represents and agrees that it has all the necessary expertise to create and implement safeguards which anticipate dangerous consequences of failures, monitor failures and their consequences, lessen the likelihood of failures that might cause harm and take appropriate remedial actions. Buyer will fully indemnify TI and its representatives against any damages arising out of the use of any TI components in safety-critical applications.

In some cases, TI components may be promoted specifically to facilitate safety-related applications. With such components, TI's goal is to help enable customers to design and create their own end-product solutions that meet applicable functional safety standards and requirements. Nonetheless, such components are subject to these terms.

No TI components are authorized for use in FDA Class III (or similar life-critical medical equipment) unless authorized officers of the parties have executed a special agreement specifically governing such use.

Only those TI components which TI has specifically designated as military grade or "enhanced plastic" are designed and intended for use in military/aerospace applications or environments. Buyer acknowledges and agrees that any military or aerospace use of TI components which have **not** been so designated is solely at the Buyer's risk, and that Buyer is solely responsible for compliance with all legal and regulatory requirements in connection with such use.

TI has specifically designated certain components as meeting ISO/TS16949 requirements, mainly for automotive use. In any case of use of non-designated products, TI will not be responsible for any failure to meet ISO/TS16949.

### Products

Audio	<a href="http://www.ti.com/audio">www.ti.com/audio</a>
Amplifiers	<a href="http://amplifier.ti.com">amplifier.ti.com</a>
Data Converters	<a href="http://dataconverter.ti.com">dataconverter.ti.com</a>
DLP® Products	<a href="http://www.dlp.com">www.dlp.com</a>
DSP	<a href="http://dsp.ti.com">dsp.ti.com</a>
Clocks and Timers	<a href="http://www.ti.com/clocks">www.ti.com/clocks</a>
Interface	<a href="http://interface.ti.com">interface.ti.com</a>
Logic	<a href="http://logic.ti.com">logic.ti.com</a>
Power Mgmt	<a href="http://power.ti.com">power.ti.com</a>
Microcontrollers	<a href="http://microcontroller.ti.com">microcontroller.ti.com</a>
RFID	<a href="http://www.ti-rfid.com">www.ti-rfid.com</a>
OMAP Applications Processors	<a href="http://www.ti.com/omap">www.ti.com/omap</a>
Wireless Connectivity	<a href="http://www.ti.com/wirelessconnectivity">www.ti.com/wirelessconnectivity</a>

### Applications

Automotive and Transportation	<a href="http://www.ti.com/automotive">www.ti.com/automotive</a>
Communications and Telecom	<a href="http://www.ti.com/communications">www.ti.com/communications</a>
Computers and Peripherals	<a href="http://www.ti.com/computers">www.ti.com/computers</a>
Consumer Electronics	<a href="http://www.ti.com/consumer-apps">www.ti.com/consumer-apps</a>
Energy and Lighting	<a href="http://www.ti.com/energy">www.ti.com/energy</a>
Industrial	<a href="http://www.ti.com/industrial">www.ti.com/industrial</a>
Medical	<a href="http://www.ti.com/medical">www.ti.com/medical</a>
Security	<a href="http://www.ti.com/security">www.ti.com/security</a>
Space, Avionics and Defense	<a href="http://www.ti.com/space-avionics-defense">www.ti.com/space-avionics-defense</a>
Video and Imaging	<a href="http://www.ti.com/video">www.ti.com/video</a>

### TI E2E Community

[e2e.ti.com](http://e2e.ti.com)

## Looking for pricing, stock, or lifecycle information?

Click below to explore more details on WIN SOURCE:

 [View CC1260RGZT](#) on WIN SOURCE

 [Texas Instruments](#) Information

## Optimize Your Supply Chain with WIN SOURCE Solutions

-  Global Sourcing Solution
-  Obsolete Management
-  Cost Control Management
-  Shortage Management
-  Alternative Solution
-  Excess Inventory Management