



**THE DATASHEET OF
XF2H-3015-1LW**



XF2 FPC Connectors

Low-profile FPC connectors
with 0.3/0.5 mm-pitch

Series
Additions

Original backlock mechanism
ensures greater work efficiency
and higher reliability.



Wide Variety from ZIF (Zero Insertion Force) to Non-ZIF

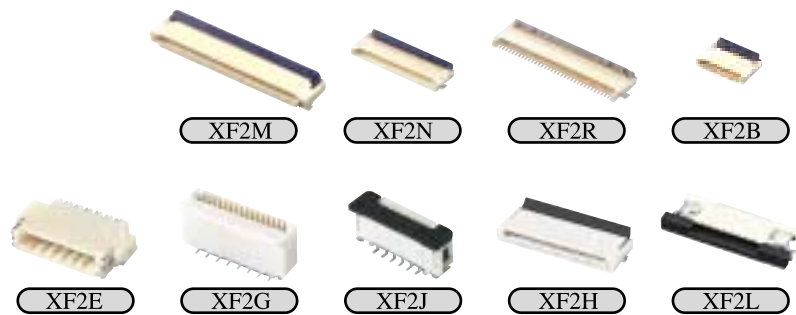

FPC See How Far FPC Connectors Have Advanced

FPC connectors must offer easy operation and secure mounting in tight work spaces. The unique construction of the XF2 Series solves all FPC mounting problems and significantly enhances work efficiency and reliability.

Meeting the rapidly increasing need for smaller dimensions, slimmer profiles, and greater functionality:

The Backlock Solution

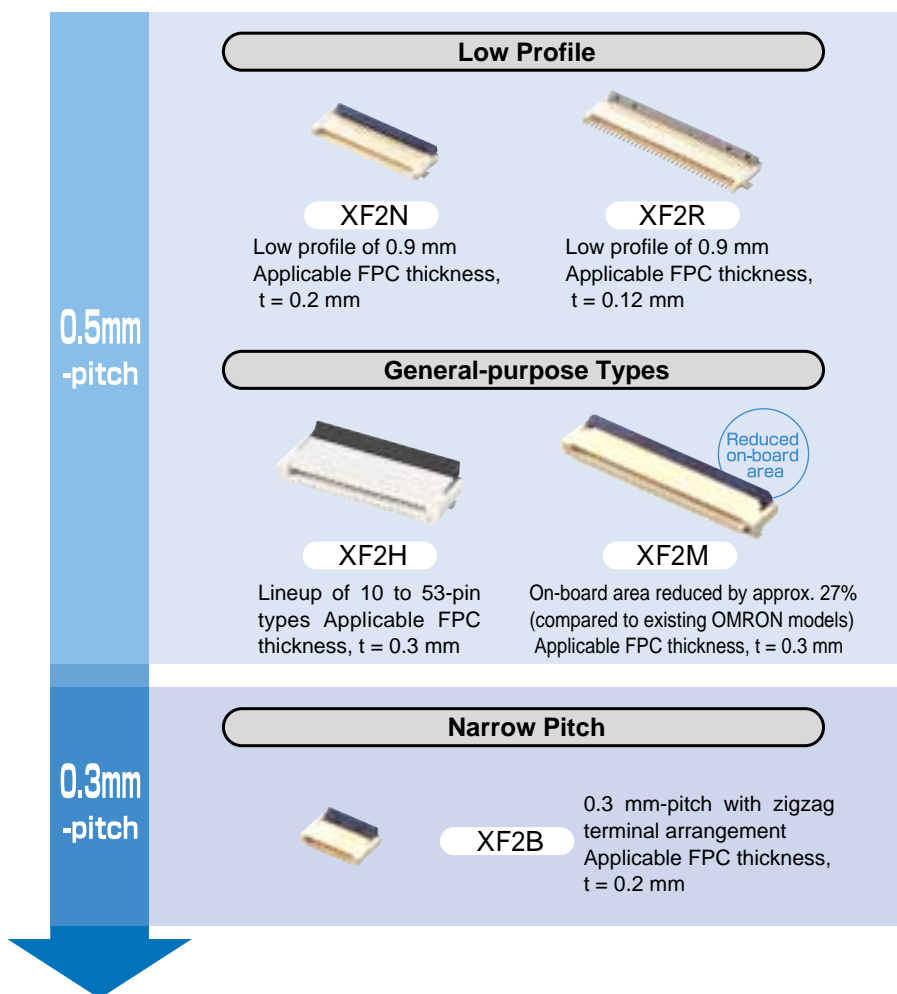

● Applications

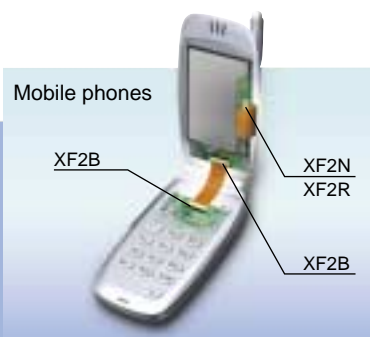

Locking Types

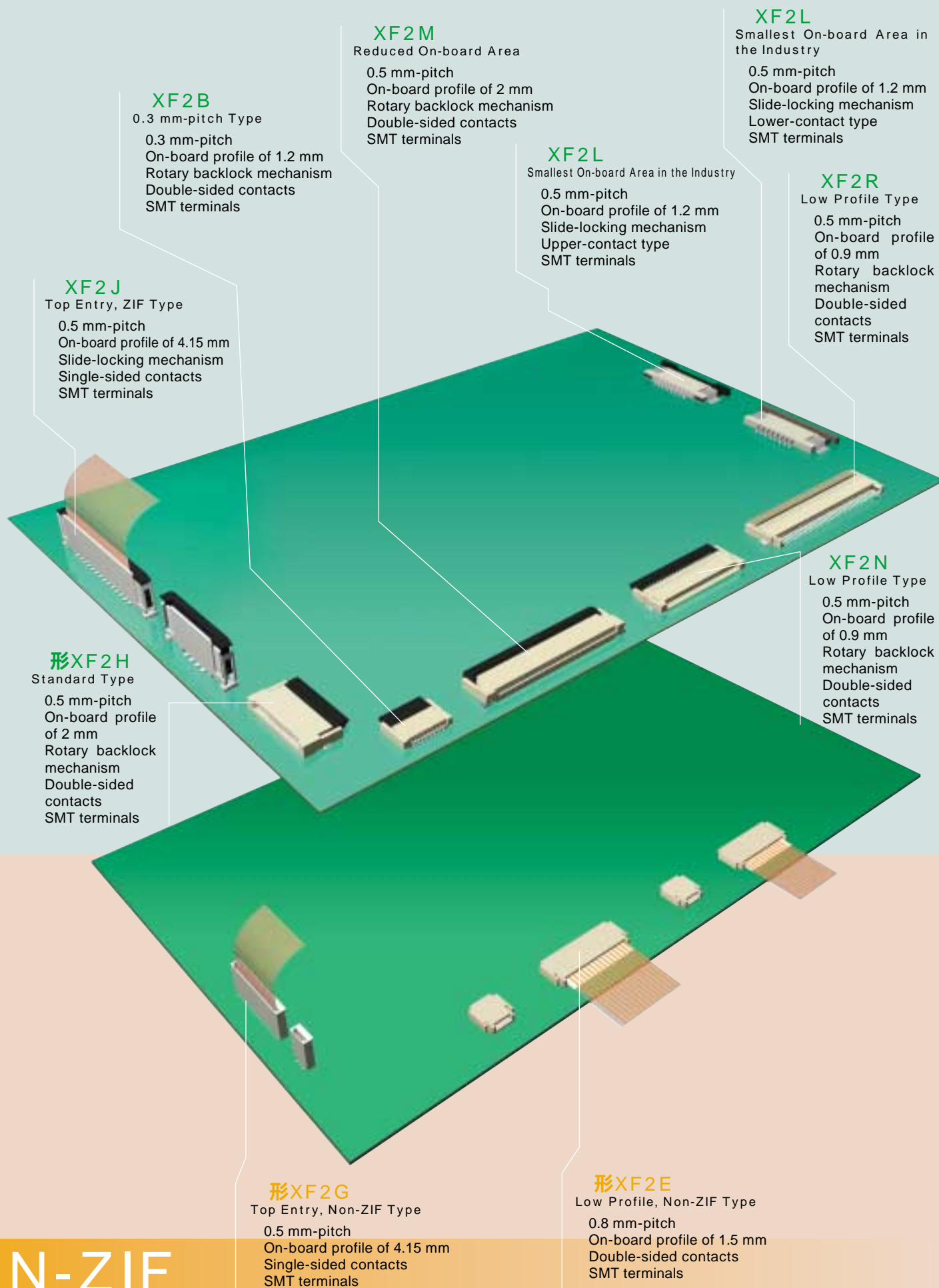

N-ZIF

Features of Rotary Backlock Mechanism

Improvement 1

Rotary slider independent of the FPC socket.

➔ Slider does not disconnect if the FPC is lifted.

High reliability. A mounted FPC will not come away if excess force is applied to it.

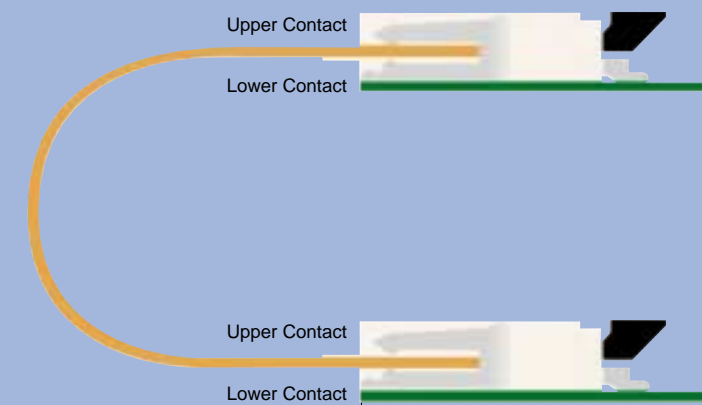
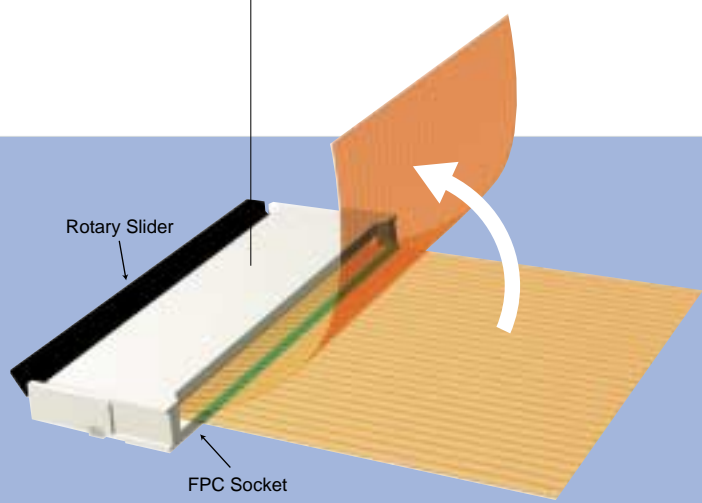

Improvement 3

Double-sided contacts

➔ No need to discriminate between the FPC upper and lower contacts.

Connector commonality makes it unnecessary to distinguish between the upper and lower contacts when connecting upper and lower PCBs.

Improvement 2

Four-shrouded FPC housing.

➔ Construction prevents FPC positional displacement.

Enhanced mounting reliability as the FPC is held in a four-shrouded housing and is unaffected by the slider operation.



Conventional Rotary Connector

1. Mount the connector.

2. Release the rotary slider.

3. Insert the FPC.

4. Lock the rotary slider.

XF2 Series

1. Mount the connector.

2. Insert the FPC.

3. Lock the rotary slider.

Improvement 4

Delivered with the rotary slider open (released).

➔ Reduces the labor required to mount FPCs.

Assembly productivity is better than with the conventional rotary locking type, as release of the rotary slider is unnecessary.

XF2B/XF2N

PCB design freedom increased with bottom wall and low profile.

The provision of a bottom wall eliminates exposure of terminals on the reverse side of the connector. The XF2N and XF2B have low on-board profiles of 0.9 mm and 1.2 mm respectively and the XF2B boasts a narrow pitch of 0.3 mm, contributing to downsizing of devices.

XF2R

Improved FPC insertion sensation.

The provision of an FPC guide section makes FPC insertion easier and improves work efficiency. The effective interface length has been increased to ensure greater reliability.

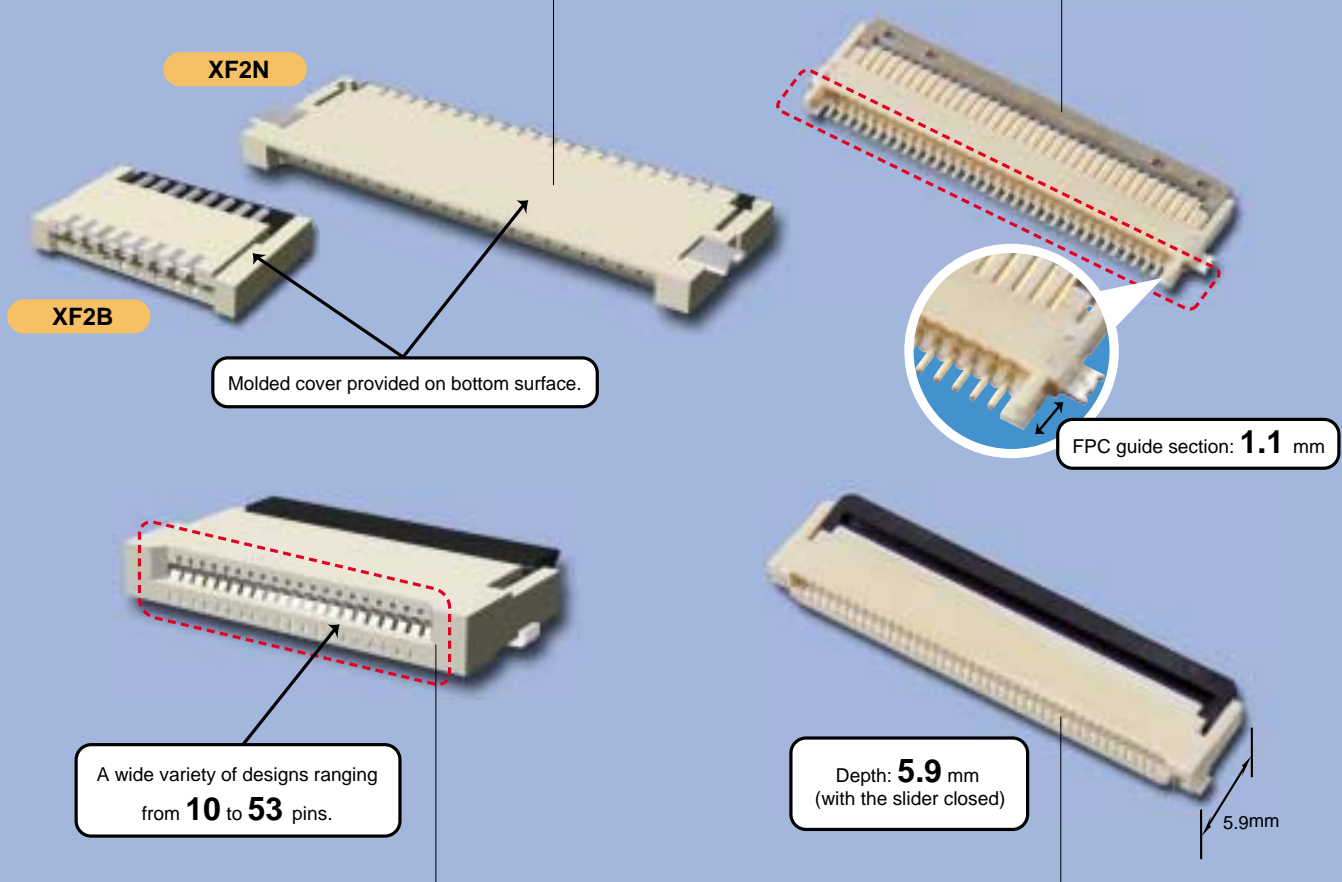

XF2H

Meeting a wide range of applications with a variety of models with between 10 and 53 pins.

Backed by reliability proved by many years of success and a new type of rotary lock construction, a broad range of models can be used to handle a wide range of applications.

XF2M

On-board mounting area approx. 27% less than the XF2H.

The depth has been significantly reduced to contribute to product downsizing.

Features of XF2L Slide-locking Mechanism

Improvement 1

Occupies the smallest on-board area and volume in the industry.

➔ **Smallest on-board area and volume in the industry achieves reduced equipment size, thickness, and weight.**

Ultra-compact size: 18.9 mm (W) Å 3.5 mm (D) Å 1.2 mm (H)*1 for 30-pin models.
*1: A maximum of 1.2 mm including tolerance.

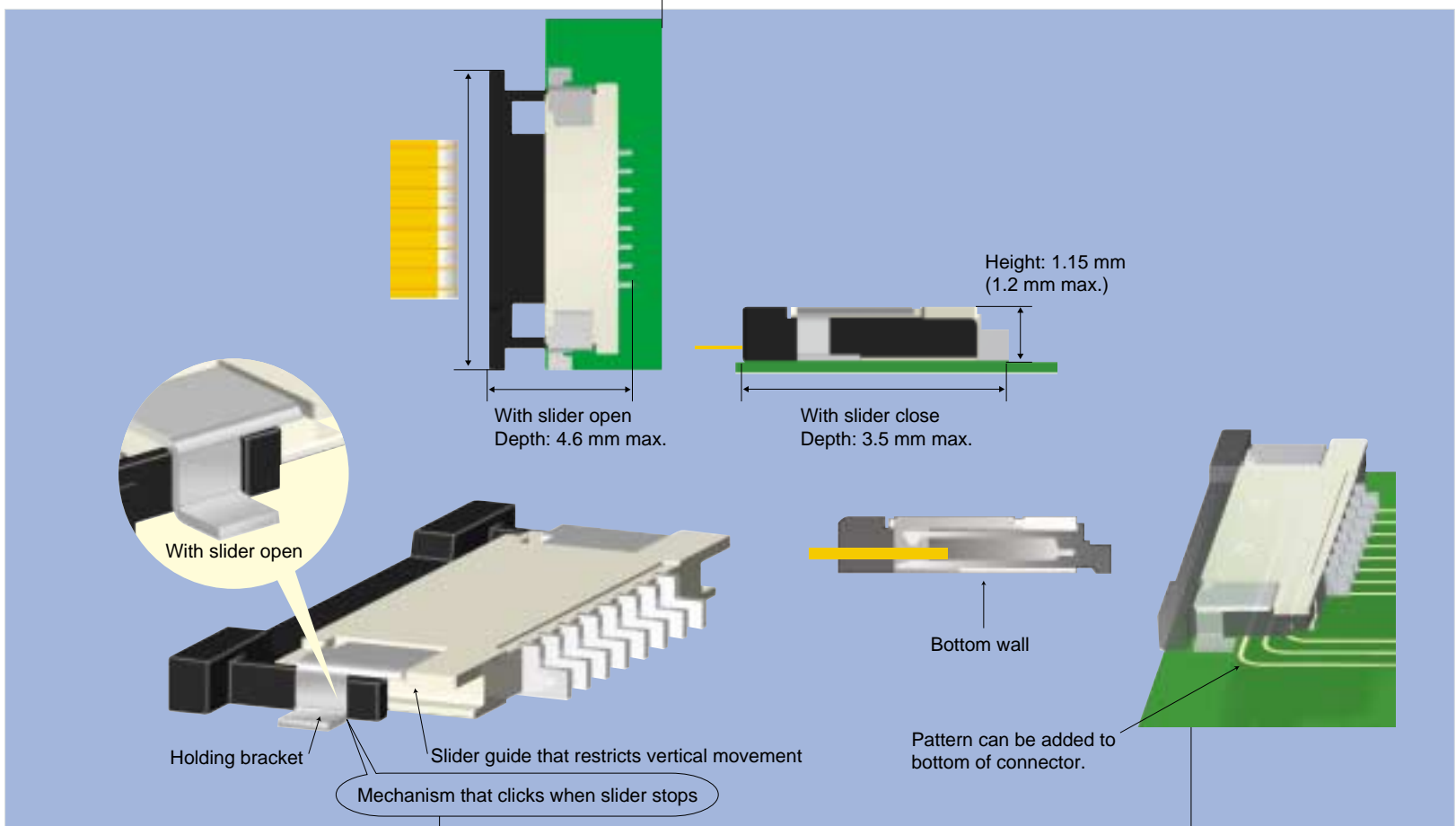

Improvement 2

Unique slider mechanism for stability and reliability.

➔ **Employs slider guide to restrict vertical movement and holding bracket to securely lock the slider.**

The slider guide prevents rattling when the slider is opened and closed to allow smooth operation. The holding bracket prevents the slider from becoming detached after the connector has been assembled.

Improvement 3

Highest board design efficiency in the industry.

➔ **Wall on reverse side of connector enhances freedom of board design.**

The wall on the reverse side of the connector prevents terminals from protruding. Circuit patterns can be added to the connector's

Rotary Backlock Type (0.3 mm-pitch)

XF2B

Rotary Backlock Mechanism and 0.3 mm-pitch Design

- Wall provided on reverse side of connector to allow greater freedom of board design.
- Double-sided (upper and lower) contact structure enables component reductions.
- Applicable FPC thickness, $t = 0.2$ mm. Gold-plated type.
- Use FPCs with the construction recommended by OMRON.
(Refer to specifications for details.)

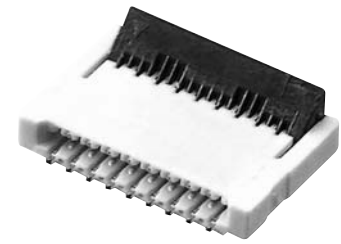

Specifications

Rated current	0.2A AC/DC
Rated voltage	50V AC/DC
Contact resistance	50m max. (at 20 mV max., 100 mA max.)
Insulation resistance	100M min. (at 250V DC)
Withstand voltage	250V AC for 1 min. (leakage current: 1 mA max.)
Insertion tolerance	20 times
Ambient operating temperature	-30 to +85°C (with no icing or condensation)

Materials/Finish

Housing	LCP resin (UL94V-0) / natural
Slider	LCP resin (UL94V-0) / black
Contact	Spring copper alloy/nickel substrate (2μm), gold-plated contacts (0.15μm)

Dimensions

XF2B-□□45-31A

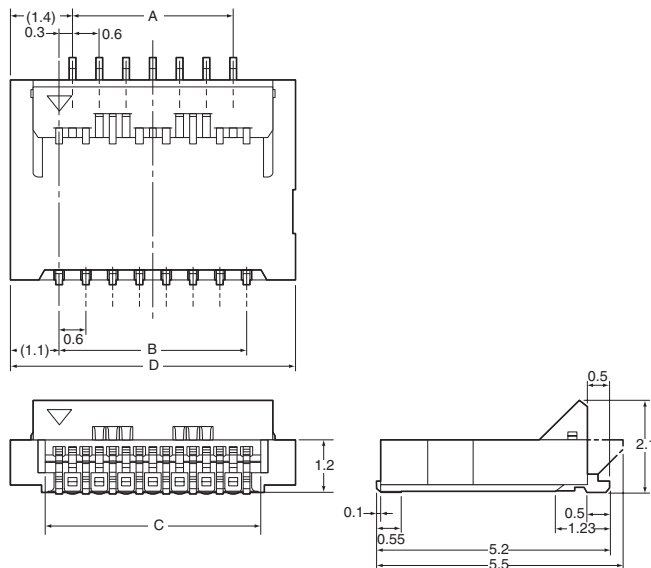
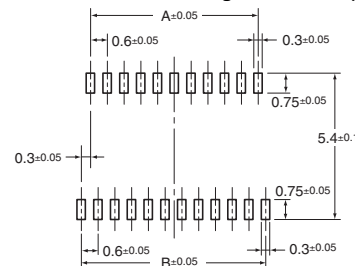

Table of Dimensions

Pins	Model	A	B	C	D
17	XF2B-1745-31A	4.2	4.8	5.5	7.0
23	XF2B-2345-31A	6.0	6.6	7.3	8.8

Printed Circuit Board Matching Dimensions (Top View)



Applicable FPC Dimensions

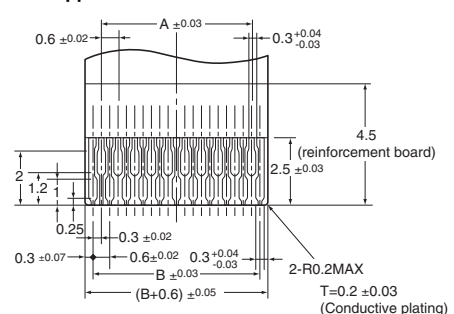

Ordering Information

Pins note 1	Model	Quantity per reel note 2
17	XF2B-1745-31A	1,500
23	XF2B-2345-31A	

note 1. Consult your OMRON representative for enquiries related to pin-number specifications.

note 2. Order an integer multiple of the quantity per reel.

Low-profile Rotary Backlock Type (0.5 mm-pitch)

XF2N

Greater Freedom of Board Design with 0.9-mm Profile and Bottom Wall

- Backlock mechanism makes FPC mounting significantly easier.
- Double-sided (upper and lower) contact structure enables component reductions.
- Applicable FPC thickness, $t = 0.2$ mm. Gold-plated type.
- Use FPCs with the construction recommended by OMRON.
(Refer to specifications for details.)

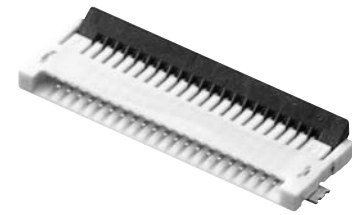

■ Specifications

Rated current	0.3A AC/DC
Rated voltage	50V AC/DC
Contact resistance	40m max. (at 20 mV max., 100 mA max.)
Insulation resistance	100 M min. (at 250 V DC)
Withstand voltage	250V AC for 1 min. (leakage current: 1 mA max.)
Insertion tolerance	20 times
Ambient operating temperature	-30 to +85°C (with no icing or condensation)

■ Materials/Finish

Housing	LCP resin (UL94V-0)/natural
Slider	LCP resin (UL94V-0)/black
Contact	Spring copper alloy/nickel substrate (1.5 μm), gold-plated contacts (0.15 μm)
Hold-down	Spring copper alloy/fused-tin plating (1.5 μm)

■ Dimensions

XF2N-□□15-3

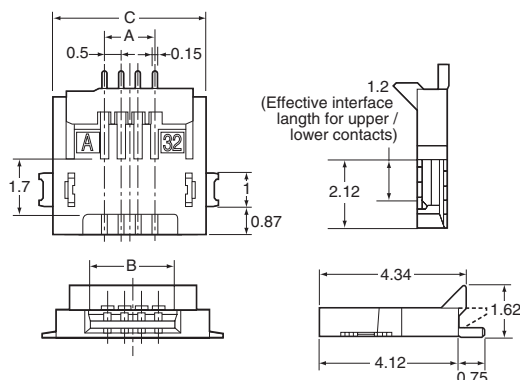

Printed Circuit Board Matching Dimensions (Top View)

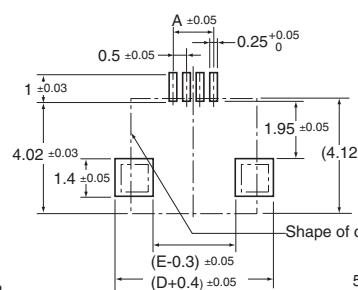

Applicable FPC Dimensions

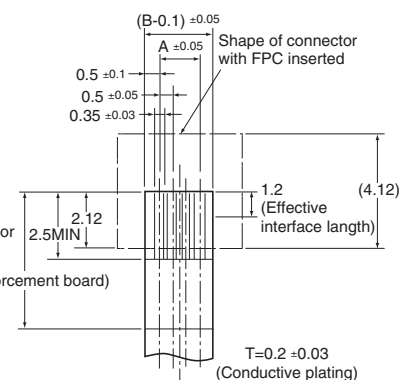

Table of Dimensions

Pins	Model	A	B	C	D	E
21	XF2N-2115-3	10.0	11.1	13.0	13.8	11.8
32	XF2N-3215-3	15.5	16.6	18.5	19.3	17.3

■ Ordering Information

Pins note 1	Model	Quantity per reel note 2
21	XF2N-2115-3	3,000
32	XF2N-3215-3	

note 1. Consult your OMRON representative for enquiries related to pin-number specifications.

note 2. Order an integer multiple of the quantity per reel.

Low-profile Rotary Backlock Type (0.5 mm-pitch)

XF2R

FPC Insertion Sensation and Work Efficiency Significantly Improved with 0.9-mm Profile and FPC Guide Section

- FPC insertion sensation greatly improved with 1.1-mm FPC guide section.
- The effective interface length for terminals has been increased to 1.4 mm to ensure stability in applications with a lot of movement.
- Double-sided (upper and lower) contact structure enables component reductions.
- Applicable FPC thickness, $t = 0.12$ mm. Gold-plated type.
- Use FPCs with the construction recommended by OMRON.
(Refer to specifications for details.)

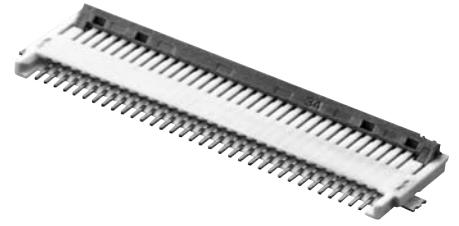

Specifications

Rated current	0.3A AC/DC
Rated voltage	50V AC/DC
Contact resistance	40m max. (at 20 mV max., 100 mA max.)
Insulation resistance	100 M min. (at 250V DC)
Withstand voltage	250V AC for 1 min. (leakage current: 1 mA max.)
Insertion tolerance	20 times
Ambient operating temperature	-30 to +85°C (with no icing or condensation)

Materials/Finish

Housing	LCP resin (UL94V-0)/natural
Slider	LCP resin (UL94V-0)/brown
Contact	Spring copper alloy/nickel substrate (1.5 μm), gold-plated contacts (0.15 μm)
Hold-down	Spring copper alloy/fused-tin plating (1.5 μm)

Dimensions

XF2R-□□15-4A

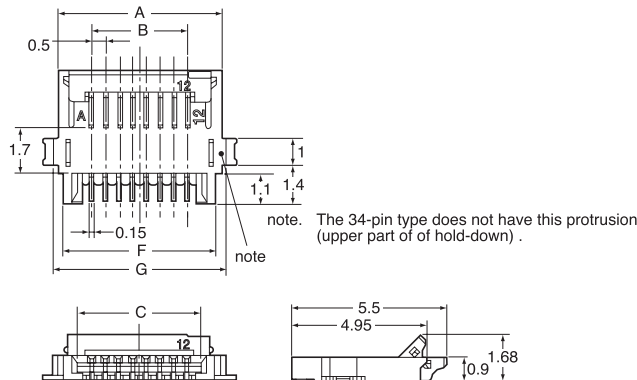

Printed Circuit Board Matching Dimensions (Top View)

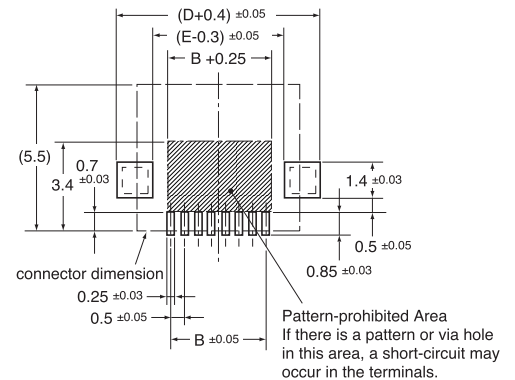

Applicable FPC Dimensions

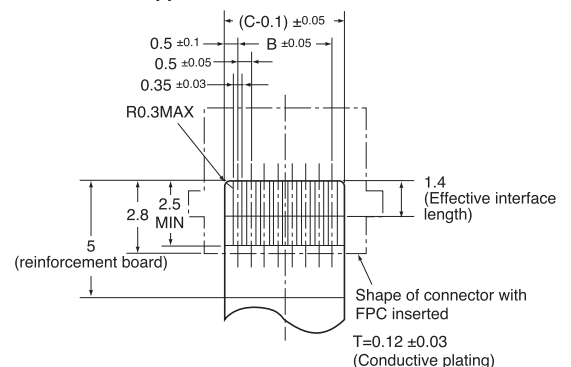

Table of Dimensions

Pins	Model	A	B	C	D	E	F	G
6	XF2R-0615-4A	5.0	2.5	3.6	6.1	4.1	4.55	5.35
9	XF2R-0915-4A	6.5	4.0	5.1	7.6	5.6	6.05	6.85
18	XF2R-1815-4A	11.0	8.5	9.6	12.1	10.1	10.55	11.35
24	XF2R-2415-4A	14.0	11.5	12.6	15.1	13.1	13.55	14.35
34	XF2R-3415-4A	19.0	16.5	17.6	20.1	18.1	18.55	-
40	XF2R-4015-4A	22.0	19.5	20.6	23.1	21.1	21.55	22.35

Ordering Information

Pins note 1	Model	Pins note 1	Model	Quantity per reel note 2
6	XF2R-0615-4A	24	XF2R-2415-4A	3,000
9	XF2R-0915-4A	34	XF2R-3415-4A	
18	XF2R-1815-4A	40	XF2R-4015-4A	

note 1. Consult your OMRON representative for enquiries related to pin-number specifications.

note 2. Order an integer multiple of the quantity per reel.

Reduced-area Rotary Backlock Type (0.5 mm-pitch)

XF2M

Reduced-area Type Requires Approx. 27% Less On-board mounting area than the XF2H

- Short body with depth of 5.9 mm (with slider closed).
- Environment-friendly type that eliminates lead from solder is available as a standard product.
- Double-sided (upper and lower) contact structure enables component reductions.
- Applicable FPC thickness, $t = 0.3$ mm.

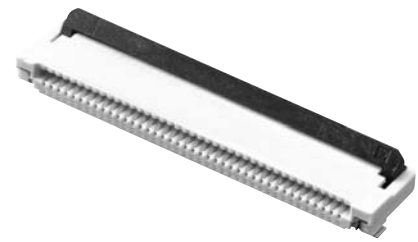

■ Specifications

Rated current	0.5A AC/DC
Rated voltage	50V AC/DC
Contact resistance	40m max. (at 20 mV max., 100 mA max.)
Insulation resistance	100 M min. (at 250V DC)
Withstand voltage	250V AC for 1 min. (leakage current: 1 mA max.)
Insertion tolerance	20 times
Ambient operating temperature	-30 to +85°C (with no icing or condensation)

■ Materials/Finish

Housing	LCP resin (UL94V-0)/natural
Slider	LCP resin (UL94V-0)/black
Contact	Spring copper alloy/nickel substrate (2 μm), tin-alloy plating (2 μm)
Hold-down	Spring copper alloy/fused-tin plating (1.5 μm)

■ Dimensions

XF2M-□□15-1F

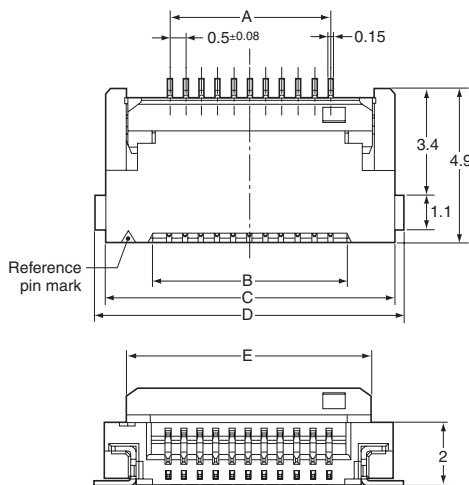

Printed Circuit Board Matching Dimensions (Top View)

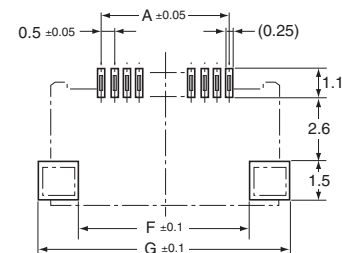

Applicable FPC Dimensions

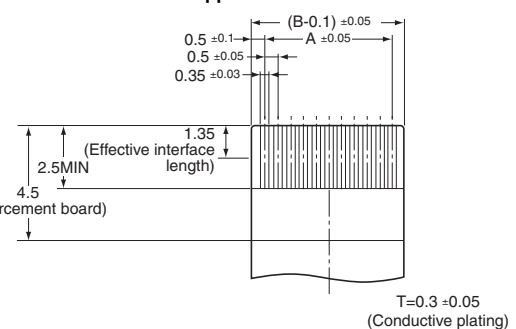

Table of Dimensions

Pins	Model	A	B	C	D	E	F	G
40	XF2M-4015-1F	19.5	20.6	23.5	24.1	22.1	21.1	24.5
50	XF2M-5015-1F	24.5	25.6	28.5	29.1	27.1	26.1	29.5

■ Ordering Information

Pins note 1	Model	Quantity per reel note 2
40	XF2M-4015-1F	1,500
50	XF2M-5015-1F	

note 1. Consult your OMRON representative for enquiries related to pin-number specifications.

note 2 Order an integer multiple of the quantity per reel.

Standard Rotary Backlock Type (0.5 mm-pitch)

XF2H

New rotary lock concept achieves high reliability and superior work efficiency.

- The unique rotary lock construction significantly improves work efficiency during FPC mounting.
- Double-sided contacts maintain a stable contact force. Discrimination between FPC upper and lower contacts is unnecessary.
- Applicable FPC thickness, $t = 0.3$ mm.



Specifications

Rated current	0.5A AC/DC
Rated voltage	50V AC/DC
Contact resistance	30m max. (at 20 mV max., 100 mA max.)
Insulation resistance	100 M min. (at 250V DC)
Withstand voltage	250V AC for 1 min. (leakage current: 1 mA max.)
Insertion tolerance	20 times
Ambient operating temperature	-30 to +85°C (with no icing or condensation)

Materials/Finish

Housing	PA6T resin (UL94V-0)/natural
Slider	LCP resin (UL94V-0)/black
Contact	Spring copper alloy/nickel substrate (2 μm), tin-alloy plating (2 μm)
Hold-down	Spring copper alloy/fused-tin plating (1.5 μm)

Dimensions

XF2H-□□15-1LW

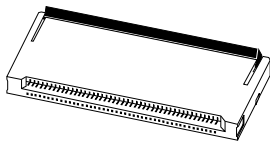
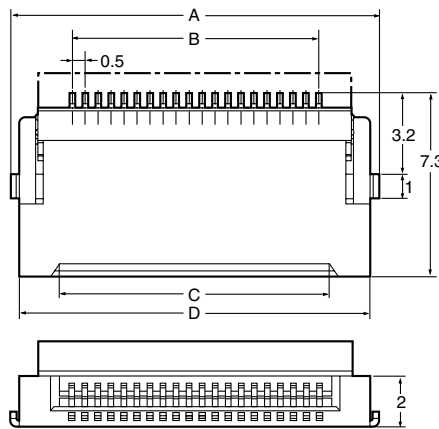
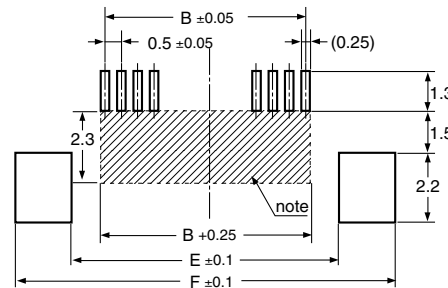

Table of Dimensions

Pins	Model	A	B	C	D	E	F
10	XF2H-1015-1LW	9.1	4.5	5.6	8.5	6.5	10.1
12	XF2H-1215-1LW	10.1	5.5	6.6	9.5	7.5	11.1
13	XF2H-1315-1LW	10.6	6.0	7.1	10.0	8.0	11.6
14	XF2H-1415-1LW	11.1	6.5	7.6	10.5	8.5	12.1
18	XF2H-1815-1LW	13.1	8.5	9.6	12.5	10.5	14.1
20	XF2H-2015-1LW	14.1	9.5	10.6	13.5	11.5	15.1
21	XF2H-2115-1LW	14.6	10.0	11.1	14.0	12.0	15.6
22	XF2H-2215-1LW	15.1	10.5	11.6	14.5	12.5	16.1
24	XF2H-2415-1LW	16.1	11.5	12.6	15.5	13.5	17.1
25	XF2H-2515-1LW	16.6	12.0	13.1	16.0	14.0	17.6
26	XF2H-2615-1LW	17.1	12.5	13.6	16.5	14.5	18.1
28	XF2H-2815-1LW	18.1	13.5	14.6	17.5	15.5	19.1
30	XF2H-3015-1LW	19.1	14.5	15.6	18.5	16.5	20.1
32	XF2H-3215-1LW	20.1	15.5	16.6	19.5	17.5	21.1
33	XF2H-3315-1LW	20.6	16.0	17.1	20.0	18.0	21.6
34	XF2H-3415-1LW	21.1	16.5	17.6	20.5	18.5	22.1
35	XF2H-3515-1LW	21.6	17.0	18.1	21.0	19.0	22.6
36	XF2H-3615-1LW	22.1	17.5	18.6	21.5	19.5	23.1
38	XF2H-3815-1LW	23.1	18.5	19.6	22.5	20.5	24.1
40	XF2H-4015-1LW	24.1	19.5	20.6	23.5	21.5	25.1
42	XF2H-4215-1LW	25.1	20.5	21.6	24.5	22.5	26.1
45	XF2H-4515-1LW	26.6	22.0	23.1	26.0	24.0	27.6
50	XF2H-5015-1LW	29.1	24.5	25.6	28.5	26.5	30.1
53	XF2H-5315-1LW	30.6	26.0	27.1	30.0	28.0	31.6



Printed Circuit Board Matching Dimensions (Top View)



note
Pattern-prohibited Area
If there is a pattern or via hole in this area, a short-circuit may occur in the terminals.

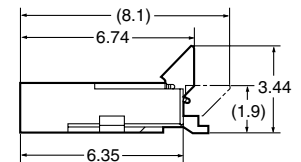

Applicable FPC Dimensions

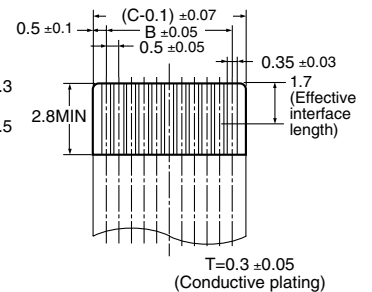

■ Ordering Information

Pins note 1	Model	Pins note 1	Model	Pins note 1	Model	Quantity per reel note 2
10	XF2H-1015-1LW	24	XF2H-2415-1LW	35	XF2H-3515-1LW	1,500
12	XF2H-1215-1LW	25	XF2H-2515-1LW	36	XF2H-3615-1LW	
13	XF2H-1315-1LW	26	XF2H-2615-1LW	38	XF2H-3815-1LW	
14	XF2H-1415-1LW	28	XF2H-2815-1LW	40	XF2H-4015-1LW	
18	XF2H-1815-1LW	30	XF2H-3015-1LW	42	XF2H-4215-1LW	
20	XF2H-2015-1LW	32	XF2H-3215-1LW	45	XF2H-4515-1LW	
21	XF2H-2115-1LW	33	XF2H-3315-1LW	50	XF2H-5015-1LW	
22	XF2H-2215-1LW	34	XF2H-3415-1LW	53	XF2H-5315-1LW	

note 1. Consult your OMRON representative for enquiries related to pin-number specifications.

note 2. Order an integer multiple of the quantity per reel.

We will also accept small lot orders (for 100 or 500 units). When ordering, please specify model numbers that end with -R100 for 100 units or -R500 for 500 units.

ZIF Slide-locking Type (0.5 mm-pitch)

XF2L

Greater Freedom of Board Design with Smallest On-board Area in Industry and Bottom Wall

- Occupies the smallest on-board area and volume in the industry.
- Low on-board profile of only 1.2 mm max.
- Highest efficiency with board design surfaces in the industry with bottom wall preventing terminal exposure.
- Construction employs secure locking mechanism.
- Applicable FPC thickness, $t = 0.3$ mm.



Specifications

Rated current	0.5A AC/DC
Rated voltage	50V AC/DC
Contact resistance	30m max. (at 20 mV DC max., 100 mA max.)
Insulation resistance	100 M min. (at 250V DC)
Withstand voltage	250V AC for 1 min. (leakage current: 1 mA max.)
Insertion tolerance	30 times
Ambient operating temperature	-30 to +85°C (with no icing or condensation)

Materials/Finish

Model Ordering	XF2L (Upper-contact Type)	XF2L (Lower-contact Type)
Housing	LCP resin (UL94V-0)/natural	
Slider	LCP resin (UL94V-0)/black	LCP resin (UL94V-0)/brown
Contact	Spring copper alloy/nickel substrate (2 μm), tin-alloy plating (2 μm)	
Hold-down	Spring copper alloy/fused-tin plating (1.5 μm)	

Dimensions

XF2L-□□□5-1

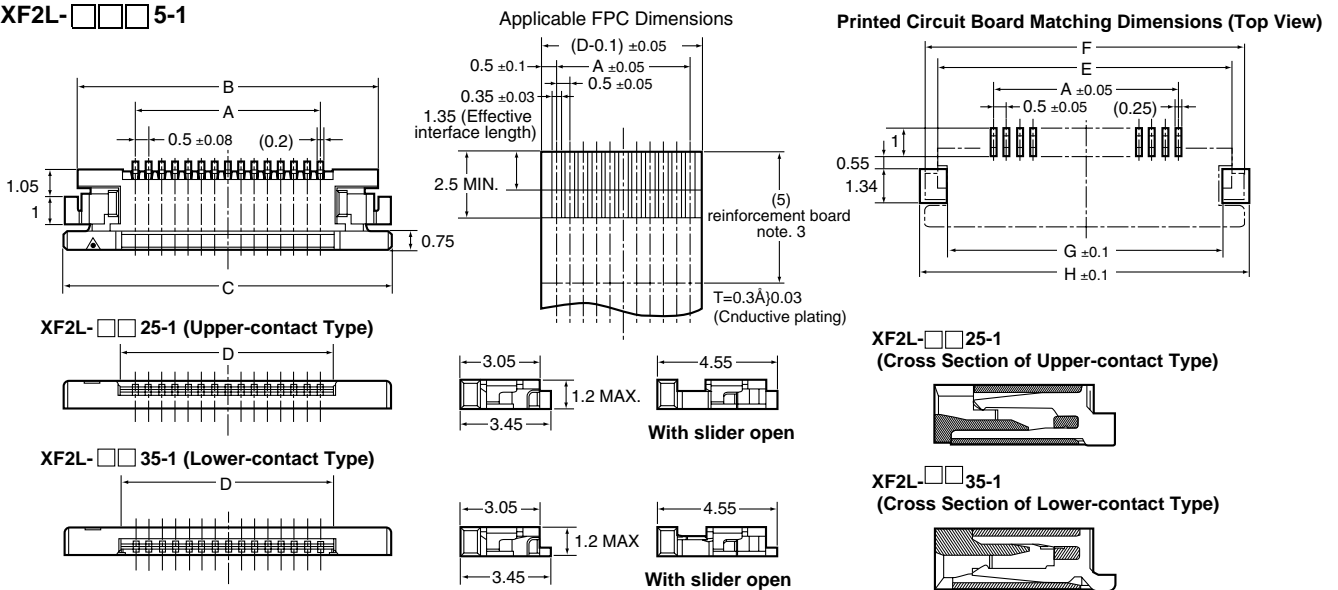

Table of Dimensions
Upper-contact Type

Pins	Model	A	B	C	D	E	F	G	H
4	XF2L-0425-1	1.5	5.9	6.9	2.6	5.88	6.88	5.28	7.28
6	XF2L-0625-1	2.5	6.9	7.9	3.6	6.88	7.88	6.28	8.28
7	XF2L-0725-1	3.0	7.4	8.4	4.1	7.38	8.38	6.78	8.78
8	XF2L-0825-1	3.5	7.9	8.9	4.6	7.88	8.88	7.28	9.28
9	XF2L-0925-1	4.0	8.4	9.4	5.1	8.38	9.38	7.78	9.78
10	XF2L-1025-1	4.5	8.9	9.9	5.6	8.88	9.88	8.28	10.28
12	XF2L-1225-1	5.5	9.9	10.9	6.6	9.88	10.88	9.28	11.28
13	XF2L-1325-1	6.0	10.4	11.4	7.1	10.38	11.38	9.78	11.78
18	XF2L-1825-1	8.5	12.9	13.9	9.6	12.88	13.88	12.28	14.28
21	XF2L-2125-1	10.0	14.4	15.4	11.1	14.38	15.38	13.78	15.78
26	XF2L-2625-1	12.5	16.9	17.9	13.6	16.88	17.88	16.28	18.28
30	XF2L-3025-1	14.5	18.9	19.9	15.6	18.88	19.88	18.28	20.28

Lower-contact Type

Pins	Model	A	B	C	D	E	F	G	H
5	XF2L-0535-1	2.0	6.4	7.4	3.1	6.38	7.38	5.78	7.78
6	XF2L-0635-1	2.5	6.9	7.9	3.6	6.88	7.88	6.28	8.28
7	XF2L-0735-1	3.0	7.4	8.4	4.1	7.38	8.38	6.78	8.78
8	XF2L-0835-1	3.5	7.9	8.9	4.6	7.88	8.88	7.28	9.28
10	XF2L-1035-1	4.5	8.9	9.9	5.6	8.88	9.88	8.28	10.28
12	XF2L-1235-1	5.5	9.9	10.9	6.6	9.99	10.88	9.28	11.28
13	XF2L-1335-1	6.0	10.4	11.4	7.1	10.38	11.38	9.78	11.78
15	XF2L-1535-1	7.0	11.4	12.4	8.1	11.38	12.38	10.78	12.78
18	XF2L-1835-1	8.5	12.9	13.9	9.6	12.88	13.88	12.28	14.28
19	XF2L-1935-1	9.0	13.4	14.4	10.1	13.38	14.38	12.78	14.78
20	XF2L-2035-1	9.5	13.9	14.9	10.6	13.88	14.88	13.28	15.28
22	XF2L-2235-1	10.5	14.9	15.9	11.6	14.88	15.88	14.28	16.28
24	XF2L-2435-1	11.5	15.9	16.9	12.6	15.88	16.88	15.28	17.28
30	XF2L-3035-1	14.5	18.9	19.9	15.6	18.88	19.88	18.28	20.28

■ Ordering Information

Pins note 1	Type	Model	Pins note 1	Type	Model	Pins note 1	Type	Model	Quantity per reel note 2
4	Upper-contact	XF2L-0425-1	10	Upper-contact	XF2L-1025-1	19	Lower-contact	XF2L-1935-1	3,000
5	Lower-contact	XF2L-0535-1		Lower-contact	XF2L-1035-1	20	Lower-contact	XF2L-2035-1	
6	Upper-contact	XF2L-0625-1	12	Upper-contact	XF2L-1225-1	21	Upper-contact	XF2L-2125-1	
	Lower-contact	XF2L-0635-1		Lower-contact	XF2L-1235-1	22	Lower-contact	XF2L-2235-1	
7	Upper-contact	XF2L-0725-1	13	Upper-contact	XF2L-1325-1	24	Lower-contact	XF2L-2435-1	
	Lower-contact	XF2L-0735-1		Lower-contact	XF2L-1335-1	26	Upper-contact	XF2L-2625-1	
8	Upper-contact	XF2L-0825-1	15	Lower-contact	XF2L-1535-1	30	Upper-contact	XF2L-3025-1	
	Lower-contact	XF2L-0835-1	18	Upper-contact	XF2L-1825-1		Lower-contact	XF2L-3035-1	
9	Upper-contact	XF2L-0925-1			Lower-contact	XF2L-1835-1	-	-	

note 1. Consult your OMRON representative for enquiries related to pin-number and lead-free plating specifications.

note 2. Order an integer multiple of the quantity per reel.

note 3. Use polyimide and thermoset adhesive for reinforcement film material.

ZIF Slide-locking Type (0.5 mm-pitch)

XF2J

Top-entry ZIF Connector

- Low on-board profile of only 4.15 mm.
- Adhesion face on top of the connector suits automatic mounting.
- Models with reverse terminal arrangement also available.
- Applicable FPC thickness, $t = 0.3$ mm.



Specifications

Rated current	0.5A AC/DC
Rated voltage	50V AC/DC
Contact resistance	30m max. (at 20 mV max., 100 mA max.)
Insulation resistance	100 M min. (at 250V DC)
Withstand voltage	250V AC for 1 min. (leakage current: 1 mA max.)
Insertion tolerance	30 times
Ambient operating temperature	-30 to +85°C (with no icing or condensation)

Materials/Finish

Housing	PA46 resin (UL94V-0)/natural
Slider	PPS resin (UL94V-0)/black LCP resin (UL94V-0)/black
Contact	Spring copper alloy/nickel substrate (2 μm), tin-alloy plating (2 μm)
Hold-down	Spring copper alloy/fused-tin plating (1.5 μm)

Dimensions

XF2J-□□ 24-11

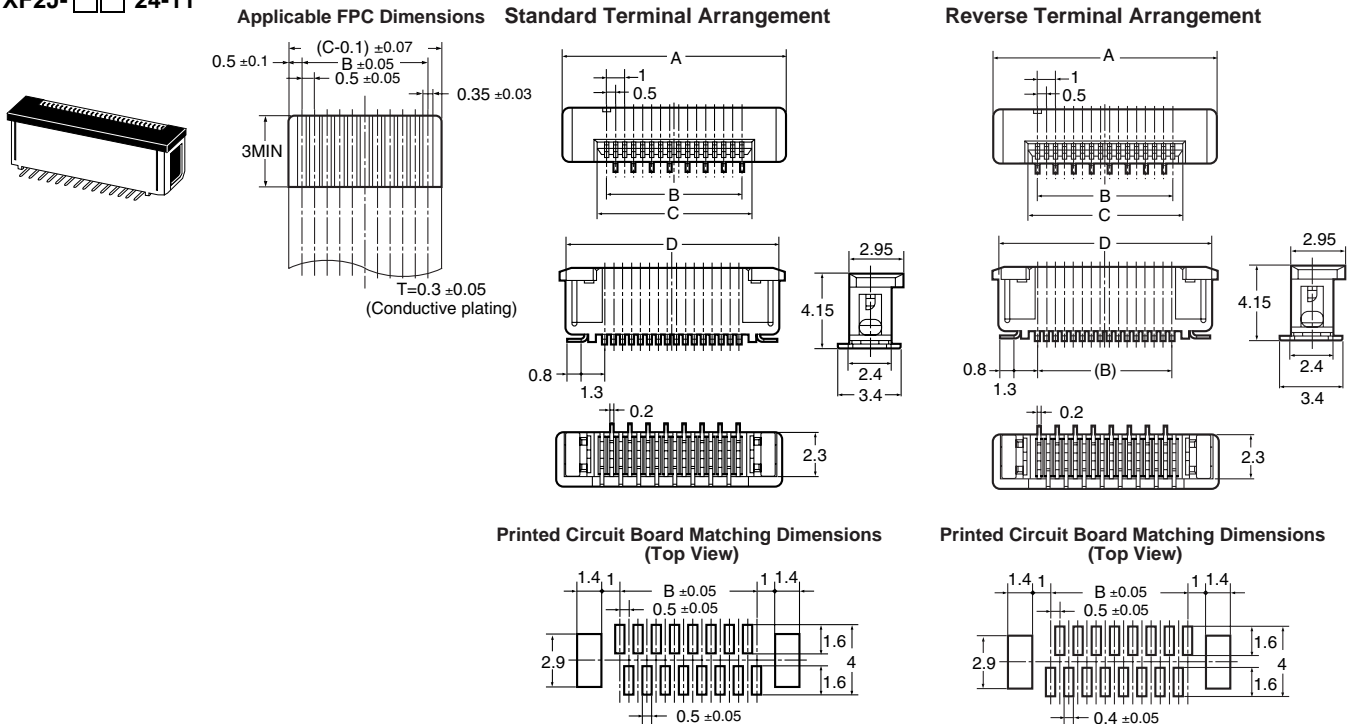

Table of Dimensions

Pins	Model		A	B	C	D
	Standard Terminal Arrangement	Reverse Terminal Arrangement				
6	XF2J-0624-11	XF2J-0624-12	7.5	2.5	3.6	6.9
8	XF2J-0824-11	XF2J-0824-12	8.5	3.5	4.6	7.9
10	XF2J-1024-11	XF2J-1024-12	9.5	4.5	5.6	8.9
12	XF2J-1224-11	XF2J-1224-12	10.5	5.5	6.6	9.9
14	XF2J-1424-11	-	11.5	6.5	7.6	10.9
16	XF2J-1624-11	XF2J-1624-12	12.5	7.5	8.6	11.9
18	XF2J-1824-11	XF2J-1824-12	13.5	8.5	9.6	12.9
20	XF2J-2024-11	XF2J-2024-12	14.5	9.5	10.6	13.9
22	XF2J-2224-11	XF2J-2224-12	15.5	10.5	11.6	14.9
24	XF2J-2424-11	XF2J-2424-12	16.5	11.5	12.6	15.9
26	XF2J-2624-11	-	17.5	12.5	13.6	16.9
28	XF2J-2824-11	-	18.5	13.5	14.6	17.9
30	XF2J-3024-11	-	19.5	14.5	15.6	18.9

■ Ordering Information

Pins note 1	Model		Quantity per reel note 2
	Standard Terminal Arrangement	Reverse Terminal Arrangement	
6	XF2J-0624-11	XF2J-0624-12	1,000
8	XF2J-0824-11	XF2J-0824-12	
10	XF2J-1024-11	XF2J-1024-12	
12	XF2J-1224-11	XF2J-1224-12	
14	XF2J-1424-11	-	
16	XF2J-1624-11	XF2J-1624-12	
18	XF2J-1824-11	XF2J-1824-12	
20	XF2J-2024-11	XF2J-2024-12	
22	XF2J-2224-11	XF2J-2224-12	
24	XF2J-2424-11	XF2J-2424-12	
26	XF2J-2624-11	-	
28	XF2J-2824-11	-	
30	XF2J-3024-11	-	

note 1. Consult your OMRON representative for enquiries related to pin-number and lead-free plating specifications.

note 2. Order an integer multiple of the quantity per reel.

note 3. We will also accept small lot orders (for 100 or 500 units). When ordering, please specify model numbers that end with -R100 for 100 units or -R500 for 500 units.

Non-ZIF Type (0.5 mm-pitch)

XF2G

Top-entry ZIF Connector

- Low on-board profile of only 4.15 mm.
- Adhesion face on top of the connector suits automatic mounting.
- Applicable FPC thickness, $t = 0.3$ mm.



Specifications

Rated current	0.5A AC/DC
Rated voltage	50V AC/DC
Contact resistance	30m max. (at 20 mV max., 100 mA max.)
Insulation resistance	100 M min. (at 250V DC)
Withstand voltage	250V AC for 1 min. (leakage current: 1 mA max.)
Insertion tolerance	10 times
Ambient operating temperature	-30 to +85°C (with no icing or condensation)

Materials/Finish

Housing	PA46 resin (UL94V-0)/natural
Contact	Spring copper alloy/nickel substrate (2 μm), tin-alloy plating (2 μm)

Dimensions

XF2G-□□14-11

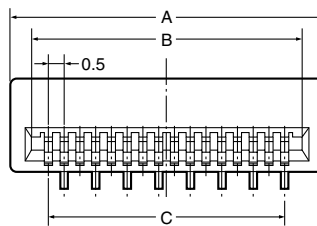
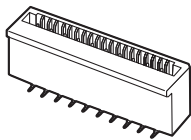

Printed Circuit Board Matching Dimensions (Top View)

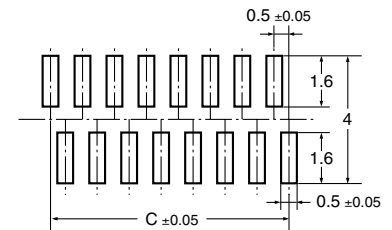
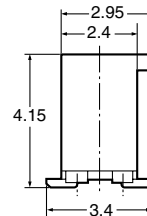
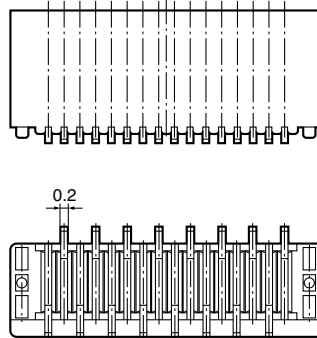
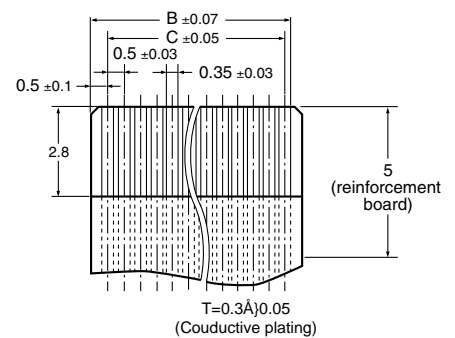

Table of Dimensions

Pins	Model	A	B	C
6	XF2G-0614-11	4.9	3.5	2.5
14	XF2G-1414-11	8.9	7.5	6.5
16	XF2G-1614-11	9.9	8.5	7.5
24	XF2G-2414-11	13.9	12.5	11.5
26	XF2G-2614-11	14.9	13.5	12.5



Applicable FPC Dimensions



Ordering Information

Pins note 1	Model	Quantity per reel note 2
6	XF2G-0614-11	1,000
14	XF2G-1414-11	
16	XF2G-1614-11	
24	XF2G-2414-11	
26	XF2G-2614-11	

note 1. Consult your OMRON representative for enquiries related to pin-number specifications.

note 2 Order an integer multiple of the quantity per reel.

Non-ZIF Type (0.8 mm-pitch)

XF2E

- Low on-board profile of only 1.5 mm.
- Double-sided contacts maintain a stable contact force.
Discrimination between FPC upper and lower contacts in unnecessary.
- Applicable FPC thickness, $t = 0.3$ mm..



Specifications

Rated current	0.5A AC/DC
Rated voltage	50V AC/DC
Contact resistance	30m max. (at 20 mV max., 100 mA max.)
Insulation resistance	100 M min. (at 250V DC)
Withstand voltage	500V AC for 1 min. (leakage current: 1 mA max.)
Insertion tolerance	10 times
Ambient operating temperature	-30 to +85°C (with no icing or condensation)

Materials/Finish

Housing	Glass-filled modified PA resin (UL94V-0)/milk white
Contact	Spring copper alloy/nickel substrate (2 μm), tin-alloy plating (2 μm)
Hold-down	Copper-alloy/copper substrate (2 μm), tin-alloy plating (2 μm)

Dimensions

XF2E-□□ 15-1

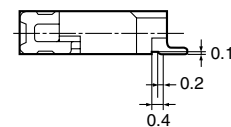
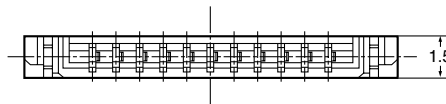
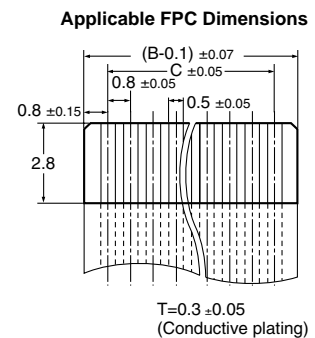
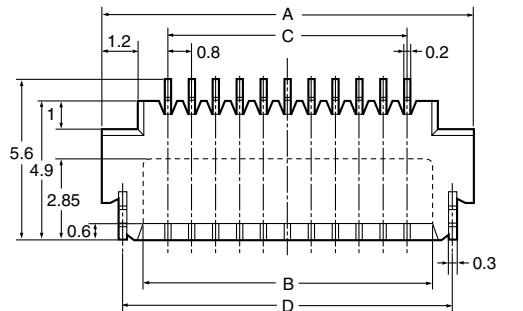
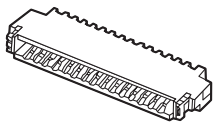
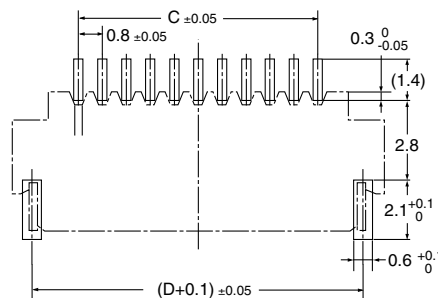

Table of Dimensions

Pins	Model	A	B	C	D
5	XF2E-0515-1	7.6	4.9	3.2	6.2
6	XF2E-0615-1	8.4	5.7	4.0	7.0
7	XF2E-0715-1	9.2	6.5	4.8	7.8
8	XF2E-0815-1	10.0	7.3	5.6	8.6
9	XF2E-0915-1	10.8	8.1	6.4	9.4
10	XF2E-1015-1	11.6	8.9	7.2	10.2
12	XF2E-1215-1	13.2	10.5	8.8	11.8
15	XF2E-1515-1	15.6	12.9	11.2	14.2
17	XF2E-1715-1	17.2	14.5	12.8	15.8
20	XF2E-2015-1	19.6	16.9	15.2	18.2

Basic Pattern Dimensions (Reference)



Ordering Information

Pins note 1	Model	Pins note 1	Model	Quantity per reel note 2
5	XF2E-0515-1	10	XF2E-1015-1	4,000
6	XF2E-0615-1	12	XF2E-1215-1	
7	XF2E-0715-1	15	XF2E-1515-1	
8	XF2E-0815-1	17	XF2E-1715-1	
9	XF2E-0915-1	20	XF2E-2015-1	

note 1. Consult your OMRON representative for enquiries related to pin-number specifications.

note 2. Order an integer multiple of the quantity per reel.

Common Precautions for XF2 Connectors

■ Precautions

Correct Use

Backlock Types

Do not lock the slider without an FPC inserted. Locking the slider without an FPC inserted will cause a decrease in the dimensions between the contacts and consequently an increase in the force required to insert an FPC.

- When designing the board, be sure to allow locking space for the slider (i.e., space for the slider when it is locked).
- The connector has a double-sided contact structure and so be sure to insert the FPC with the correct orientation.
- When locking the slider, press it down securely with your fingers at both ends.
Failing to lock the slider properly may result in contact failure.
- Unlocking the Slider
Unlock the slider manually. Place your index fingers at both ends of the slider and lift it up. Do not apply excessive force when lifting the slider. Doing so may result in the slider being damaged or detached. If the slider becomes detached, it may not be able to hold the FPC and contact failure may result.

All Models

- Insert the FPC right to the back of the connector. Failing to do so may result in a loss of contact reliability.
- After mounting (and locking) the FPC, do not bend or pull it with excessive force. Doing so may result in FPC disconnection.
- When bending the FPC after mounting to the PCB, do not bend it excessively near the place where it enters the connector. Doing so may result in a loss of contact reliability.
- In applications where the connector may frequently be exposed to shock or vibration, or where, as part of a mechanism, connected parts may move, secure the FPC and make sure that it is not subjected to a direct load.
- Do not perform reflow or manual soldering with the FPC inserted in the connector. Doing so may result in a loss of contact reliability.
- Unlock the slider before removing the FPC.
- Use an FPC with the structure recommended by OMRON.
- Do not perform reflow or manual soldering with the slider locked. Doing so may result in a loss of contact reliability.
- Observe a metal mask thickness of $t = 0.12$ to 0.15 mm.
- Metal mask open area ratio: 90% of the printed circuit board matching dimensions in the dimensions diagrams.

Recommended Reflow Conditions

	Standard reflow conditions	Reflow conditions for lead-free solder (backlock type only)
Preheating temperature	150 ± 10°C	150 to 180°C
Time	60 to 120 s	60 to 120 s
Soldering temperature	200 to 240°C	230 to 250°C
Time (10 s max. at the maximum temperature 240°C)	30 s max.	30 s max.

Storage

1. Do not store in locations subject to dust or high humidity levels.
2. Do not store in locations close to sources of gases such as ammonia gas or sulphide gas.

ALL DIMENSIONS SHOWN ARE IN MILLIMETERS.

To convert millimeters into inches, multiply by 0.03937. To convert grams into ounces, multiply by 0.03527.

Cat. No. G011-E1-02 **In the interest of product improvement, specifications are subject to change without notice.**

OMRON Corporation

**MARKETING SECTION
CONNECTOR DEPARTMENT**

Electronic & Mechanical Components Division H.Q.

Work Shop4, Manufacturing Development Center

2-1, 2-Chome, Nishikusatsu, Kusatsu-City,
Shiga, 525-0035 Japan

Tel: (81)77-565-5314/Fax: (81)77-565-5581

Printed in Japan
0503-3M (0199)



Looking for pricing, stock, or lifecycle information?

Click below to explore more details on WIN SOURCE:

 [View XF2H-3015-1LW on WIN SOURCE](#)

 [Omron Information](#)

Optimize Your Supply Chain with WIN SOURCE Solutions

-  Global Sourcing Solution
-  Obsolete Management
-  Cost Control Management
-  Shortage Management
-  Alternative Solution
-  Excess Inventory Management