

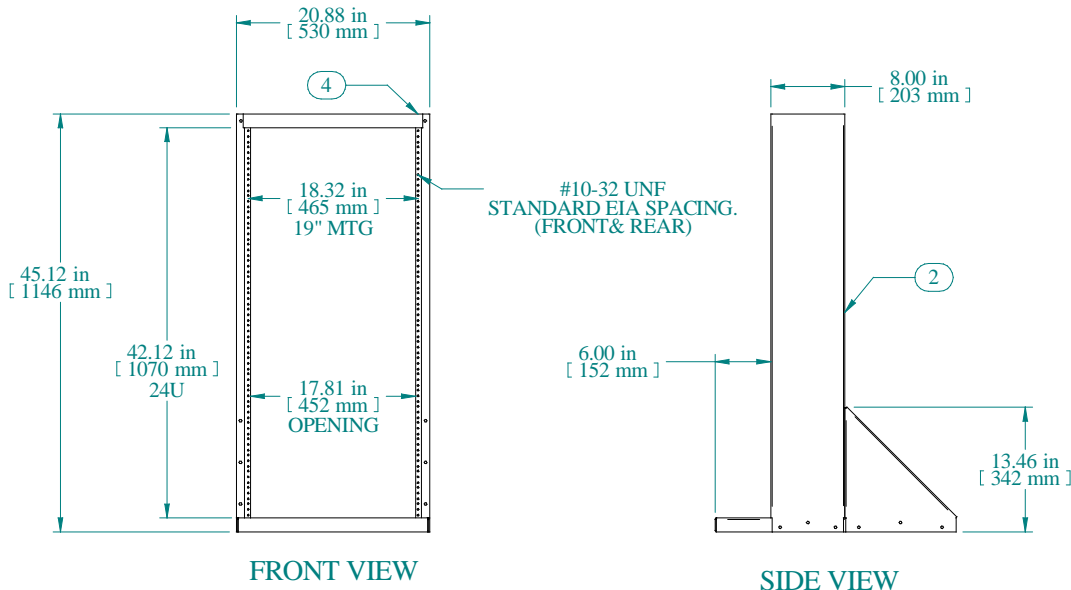

**THE DATASHEET OF
DNRR1942DCK**

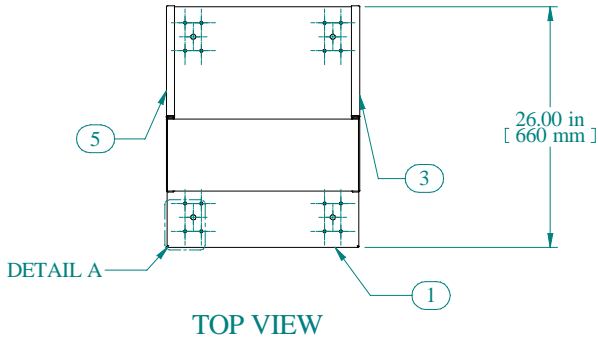

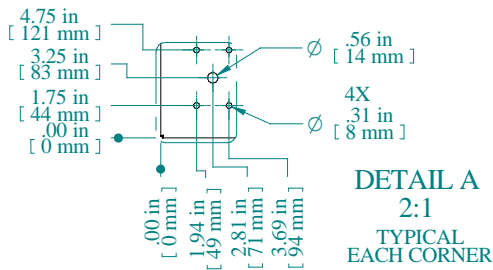

Item Number	Title	Quantity
1	DNRRDCK - BASE	1
2	DNRRDCK - RAIL	2
3	DNRRDCK - L.H GUSSET	1
4	DNRRDCK - TOP	1
5	DNRRDCK - R.H GUSSET	1

PART NUMBERS	
DNRR1942DCK	PAINTED BLACK THIN FILM

NOTES
Shipped knockdown for handling ease & protection Includes assembly hardware See Hammond Website for Additional Accessories

Data subject to change without notice. Isometric drawing not to scale.

**HAMMOND
MANUFACTURING™**

www.hammondmfg.com

PART NO. DNRR1942DCK

Looking for pricing, stock, or lifecycle information?

Click below to explore more details on WIN SOURCE:

- [⊖ View DNRR1942DCK on WIN SOURCE](#)
- [⊖ Hammond Manufacturing Information](#)

Optimize Your Supply Chain with WIN SOURCE Solutions

- ✓ Global Sourcing Solution
- ✓ Obsolete Management
- ✓ Cost Control Management
- ✓ Shortage Management
- ✓ Alternative Solution
- ✓ Excess Inventory Management