



**THE DATASHEET OF
DCMOTORCONTRBTN8982TOB01**



Product Brief

NovalithIC™ BTN8982TA

Integrated high current half-bridge motor drivers

The BTN8982TA is an integrated high current half-bridge for motor drive applications. It is part of the NovalithIC™ family containing one p-channel high-side MOSFET and one n-channel low-side MOSFET with an integrated driver IC in one package.

Due to the p-channel high-side switch the need for a charge pump is eliminated thus minimizing EMI.

Interfacing to a microcontroller is made easy by the integrated driver IC which features logic level inputs, diagnosis with current sense, slew rate adjustment, dead time generation and protection against overtemperature, undervoltage, overcurrent and short circuit.

The BTN8982TA provides a cost optimized solution for protected high current PWM motor drives with very low board space consumption.

Key benefits

- › **Easy to use and fast design-in** – driver, FETs, load current sensing and diagnostic and protection functions – all integrated in one package, promoting fast and lean design-in activities
- › **Full flexibility** – the BTN8982TA supports BDC motors in half- or H-bridge configuration as well as BLDC motors
- › **Cost optimized through system level savings** – compared to a discrete solution, the BTN8982TA saves PCB-area and pick and place costs. Furthermore it requires less passives due to its integrated diagnosis and protection functions.
- › **Functional safety** – the BTN8982TA includes an integrated under voltage, MOSFETs' overtemperature- and overcurrent protection, measured directly in the MOSFETs. In an H-bridge configuration, the BTN8982TA furthermore provides a redundancy case for functional safety.
- › **Configuration flexibility** – settable switching speed for optimized EMI vs. power dissipation

Performance BTN8982TA

Key features

- › Path resistance: max. 20.4 mΩ at 150°C (typ. 10.0 mΩ at 25°C)
 - High side: max. 10.5 mΩ at 150°C (typ. 5.3 mΩ at 25°C)
 - Low side: max. 9.9 mΩ at 150°C (typ. 4.7 mΩ at 25°C)
- › Capable for high PWM frequency combined with active freewheeling
- › Extended operating voltage range down to 5.5 V (high side switch) and up to 40 V
- › Current limitation level of 55 A min.
- › Status flag diagnosis with current sense capability
- › Overtemperature shut down with latch behavior and undervoltage shut down
- › Driver circuit with logic level inputs
- › Green product (RoHS compliant)
- › AEC-qualified

NovalithIC™ BTN8982TA

Integrated high current half-bridge motor drivers

Block diagram

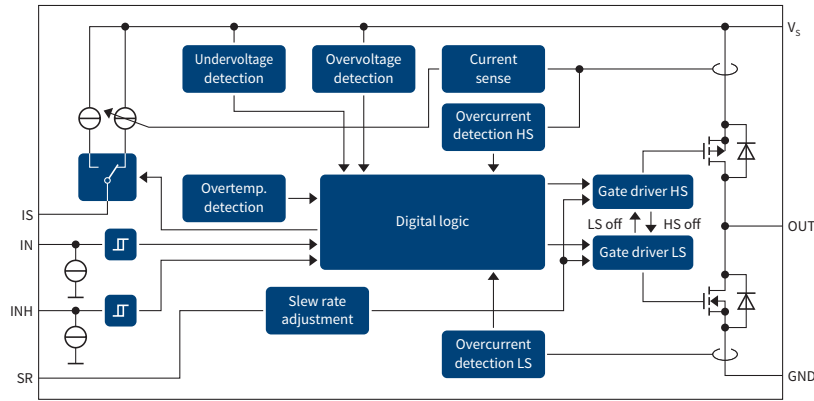

Applications diagram

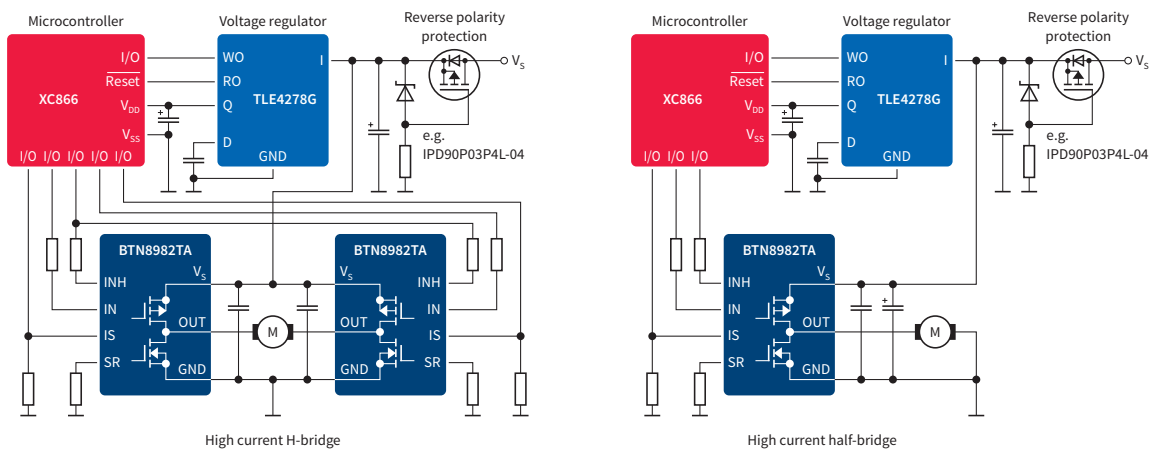

Applications: high current DC- or brushless DC (BLDC) motor drives for use in applications like:

- > Power windows
- > Sun roof
- > Central door lock
- > Seat positioning
- > Front and rear wiper
- > 4 wheel transfer case
- > Electronically Controlled Manual Transmission (ECMT)
- > Cooling fan / HVAC blower
- > Seat belt pretensioner
- > Electric parking brake
- > Sliding door/door soft close
- > Power lift gate
- > Fuel pump / water pump
- > Industrial motor drives (automation, home appliance, robotics, medical)

Published by
Infineon Technologies AG
85579 Neuburg, Germany

© 2016 Infineon Technologies AG.
All Rights Reserved.

Please note!

THIS DOCUMENT IS FOR INFORMATION PURPOSES ONLY AND ANY INFORMATION GIVEN HEREIN SHALL IN NO EVENT BE REGARDED AS A WARRANTY, GUARANTEE OR DESCRIPTION OF ANY FUNCTIONALITY, CONDITIONS AND/OR QUALITY OF OUR PRODUCTS OR ANY SUITABILITY FOR A PARTICULAR PURPOSE. WITH REGARD TO THE TECHNICAL SPECIFICATIONS OF OUR PRODUCTS, WE KINDLY ASK YOU TO REFER TO THE RELEVANT PRODUCT DATA SHEETS PROVIDED BY US. OUR CUSTOMERS AND THEIR TECHNICAL DEPARTMENTS ARE REQUIRED TO EVALUATE THE SUITABILITY OF OUR PRODUCTS FOR THE INTENDED APPLICATION.

WE RESERVE THE RIGHT TO CHANGE THIS DOCUMENT AND/OR THE INFORMATION GIVEN HEREIN AT ANY TIME.

Additional information

For further information on technologies, our products, the application of our products, delivery terms and conditions and/or prices, please contact your nearest Infineon Technologies office (www.infineon.com).

Warnings

Due to technical requirements, our products may contain dangerous substances. For information on the types in question, please contact your nearest Infineon Technologies office.

Except as otherwise explicitly approved by us in a written document signed by authorized representatives of Infineon Technologies, our products may not be used in any life-endangering applications, including but not limited to medical, nuclear, military, life-critical or any other applications where a failure of the product or any consequences of the use thereof can result in personal injury.

Looking for pricing, stock, or lifecycle information?

Click below to explore more details on WIN SOURCE:

- ⊖ [View DCMOTORCONTRBTN8982TOBO1 on WIN SOURCE](#)
- ⊖ [Infineon Technologies Information](#)

Optimize Your Supply Chain with WIN SOURCE Solutions

- ✓ Global Sourcing Solution
- ✓ Obsolete Management
- ✓ Cost Control Management
- ✓ Shortage Management
- ✓ Alternative Solution
- ✓ Excess Inventory Management