



**THE DATASHEET OF
BR3510-G**



BR10/15/25/35/50A -G SERIES

"-G" : RoHS Device

REVERSE VOLTAGE - 50 to 1000V

FORWARD CURRENT - 10/15/25/35/50 A

FEATURES

- Surge overload -240~500amperes peak
- Low forward voltage drop
- Mounting position: Any
- Electrically isolated base -2000 Volts
- Solderable 0.25" FASTON terminals
- Materials used carries U/L recognition

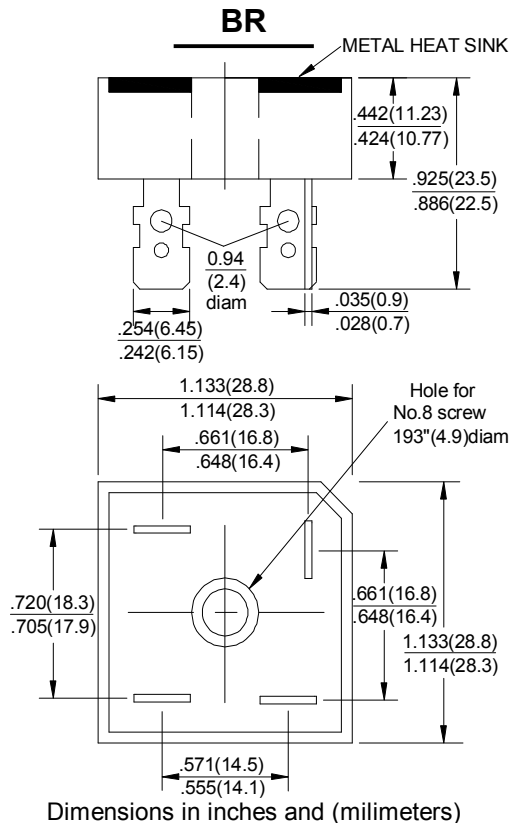

Dimensions in inches and (millimeters)

MAXIMUM RATINGS AND ELECTRICAL CHARACTERISTICS

Rating at 25°C ambient temperature unless otherwise specified.

Resistive or inductive load 60HZ.

For capacitive load current by 20%

CHARACTERISTICS	SYMBOL	BR	BR	BR	BR	BR	BR	BR	UNIT			
		10005	1001	1002	1004	1006	1008	1010				
Maximum Recurrent Peak Reverse Voltage	V _{RRM}	50	100	200	400	600	800	1000	V			
Maximum RMS Bridge Input Voltage	V _{RMS}	35	70	140	280	420	560	700	V			
Maximum Average Forward Rectified Output Current @T _c =55°C	I _(AV)	BR 10	10	BR 15	15	BR 25	25	BR 35	35	BR 50	50	A
Peak Forward Surge Current 8.3ms Single Half Sine-Wave Super Imposed on Rated Load	I _{FSM}	BR 10	240	BR 15	300	BR 25	400	BR 35	400	BR 50	500	A
Maximum Forward Voltage Drop Per Element at 5.0/7.5/12.5/17.5/25.0A Peak	V _F	1.1								V		
Maximum Reverse Current at Rated DC Blocking Voltage Per Element @T _A =25°C	I _R	10.0								µA		
Operating Temperature Rang	T _J	-55 to +125								°C		
Storage Temperature Rang	T _{STG}	-55 to +125								°C		

RATINGS AND CHARACTERISTIC CURVES BR10/15/25/35/50A -G SERIES

FIG.1-MAXIMUM FORWARD SURGE CURRENT

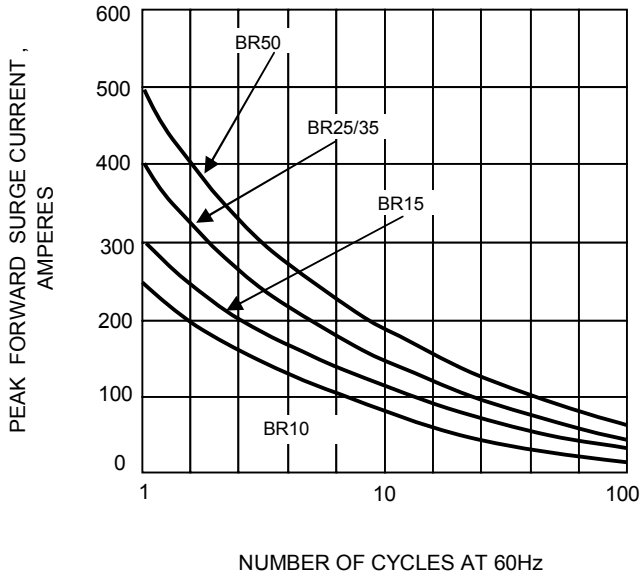

FIG.2- DERATING CURVE OUTPUT RECTIFIED CURRENT

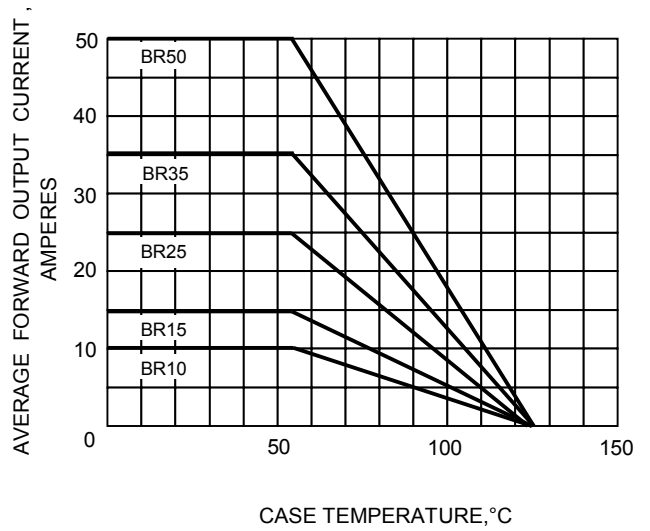

FIG.3-TYPICAL FORWARD CHARACTERISTICS

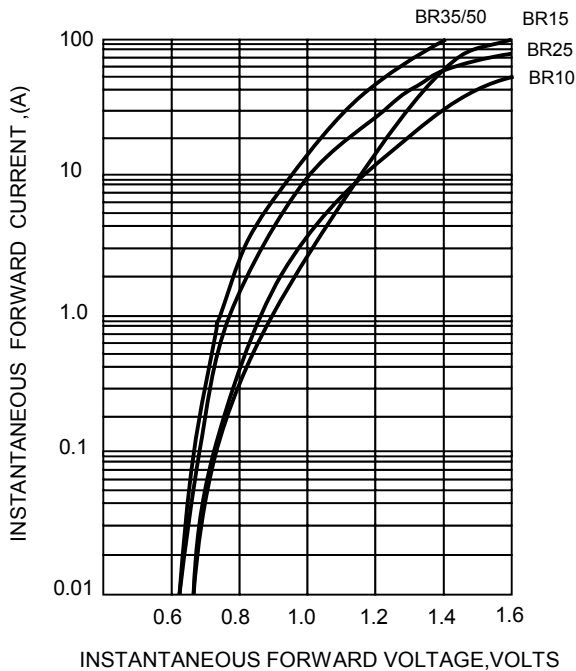
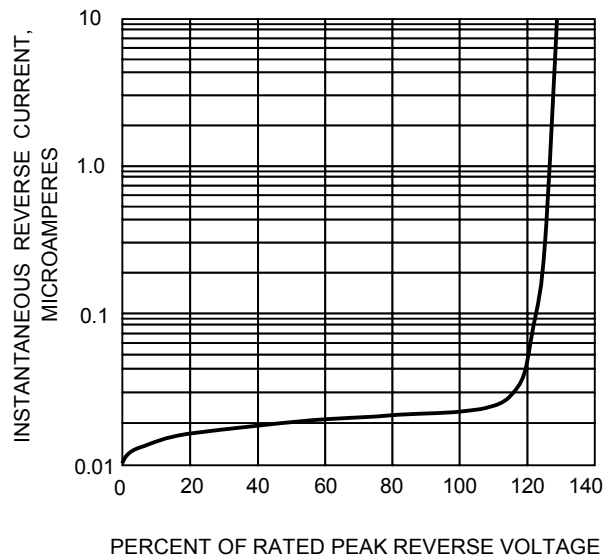



FIG.4-TYPICAL REVERSE CHARACTERISTICS







Looking for pricing, stock, or lifecycle information?

Click below to explore more details on WIN SOURCE:

-  [View BR3510-G on WIN SOURCE](#)
-  [Comchip Technology Information](#)

Optimize Your Supply Chain with WIN SOURCE Solutions

-  Global Sourcing Solution
-  Obsolete Management
-  Cost Control Management
-  Shortage Management
-  Alternative Solution
-  Excess Inventory Management