



**THE DATASHEET OF
BQ771808DPJT**



bq7718 Overvoltage Protection for 2-Series to 5-Series Cell Li-Ion Batteries with Internal Delay Timer

1 Features

- 2-, 3-, 4-, and 5-Series Cell Overvoltage Protection
- Internal Delay Timer
- Fixed OVP Threshold
- High-Accuracy Overvoltage Protection: ± 10 mV
- Low Power Consumption $I_{CC} \approx 1$ μ A ($V_{CELL(ALL)} < V_{PROTECT}$)
- Low Leakage Current Per Cell Input < 100 nA
- Small Package Footprint
 - 8-pin QFN (3.00 mm \times 4.00 mm)

2 Applications

- Protection for Li-Ion Battery Packs Used in:
 - Handheld Garden Tools
 - Handheld Power Tools
 - Cordless Vacuum Cleaners
 - UPS Battery Backup
 - Light Electric Vehicles (eBike, eScooter, Pedal Assist Bicycles)

3 Description

The bq7718xy family of products provide an overvoltage monitor and protector for Li-Ion battery pack systems. Each cell is monitored independently for an overvoltage condition. For quicker production-line testing, the bq7718xy device provides a Customer Test Mode (CTM) with greatly reduced delay time.

In the bq7718xy device, an internal delay timer is initiated upon detection of an overvoltage condition on any cell. Upon expiration of the delay timer, the output is triggered into its active state (either high or low depending on the configuration).

Device Information Table⁽¹⁾

PART NUMBER	PACKAGE	BODY SIZE (NOM)
bq771800	WSON (8)	3.00 mm \times 4.00 mm

(1) For all available packages, see the orderable addendum at the end of the data sheet and the [Device Comparison Table](#).

Simplified Schematic

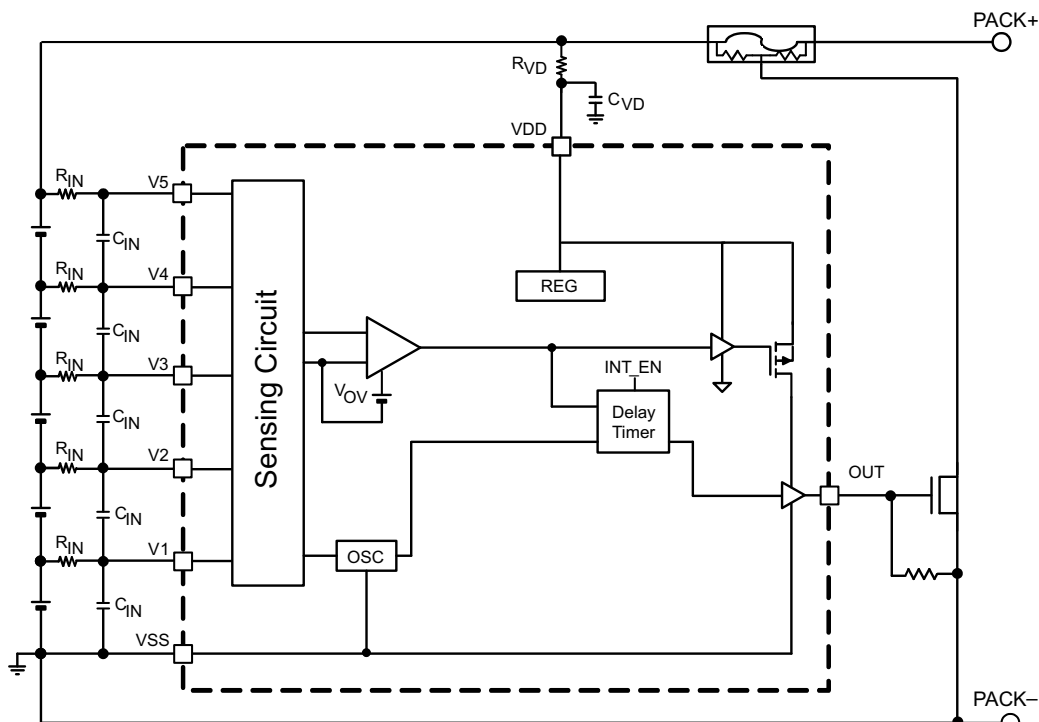

Copyright © 2016, Texas Instruments Incorporated



Table of Contents

1 Features	1	8.3 Feature Description.....	9
2 Applications	1	8.4 Device Functional Modes.....	10
3 Description	1	9 Application and Implementation	12
4 Revision History	2	9.1 Application Information.....	12
5 Device Comparison Table	3	9.2 Systems Examples.....	15
6 Pin Configuration and Functions	4	10 Power Supply Recommendations	15
7 Specifications	5	11 Layout	16
7.1 Absolute Maximum Ratings	5	11.1 Layout Guidelines	16
7.2 ESD Ratings	5	11.2 Layout Example	16
7.3 Recommended Operating Conditions.....	5	12 Device and Documentation Support	17
7.4 Thermal Information	5	12.1 Related Links	17
7.5 DC Characteristics	6	12.2 Receiving Notification of Documentation Updates	17
7.6 Timing Requirements.....	7	12.3 Community Resources.....	17
7.7 Typical Characteristics.....	8	12.4 Trademarks	17
8 Detailed Description	9	12.5 Electrostatic Discharge Caution.....	17
8.1 Overview	9	12.6 Glossary	17
8.2 Functional Block Diagram	9	13 Mechanical, Packaging, and Orderable Information	18

4 Revision History

NOTE: Page numbers for previous revisions may differ from page numbers in the current version.

Changes from Revision F (August 2017) to Revision G	Page
• Added the bq771811 and bq771818 devices to Production Data.....	3
• Added the bq771820 device to the Device Comparison Table	3
• Added bq771820 to DC Characteristics	6
• Added bq771820 to Timing Requirements	7

Changes from Revision E (March 2017) to Revision F	Page
• Deleted preview products from the Device Comparison Table	3
• Added bq771818 to the Device Comparison Table	3
• Clarified OV Hysteresis, Output Delay and Output Drive options	3
• Deleted preview products from V_{OV} DC Characteristics	6
• Deleted preview products from V_{HYS} DC Characteristics	6
• Added bq771818 and bq771819 delay settings to Timing Requirements	7

Changes from Revision D (November 2014) to Revision E	Page
• Changed the data sheet device number to bq7718	1
• Added the Block Diagram image	1
• Added the bq771817 device to the Device Comparison Table	3
• Replaced the pinout image in the Pin Configuration and Functions section	4
• Deleted "Lead temperature (soldering, 10 s)" from the Absolute Maximum Ratings table	5
• Changed the Handling Ratings table to ESD Ratings table	5
• Removed the Product Preview note from bq771806 in the DC Characteristics table.....	6
• Added bq771817 to V_{HYS} DC Characteristics	6
• Added the Timing Requirements table	7
• Added the Feature Description section	9

• Added the <i>Device Functional Modes</i> section	10
• Added the <i>Power Supply Recommendations</i> section	15
• Added the <i>Layout</i> section	16

Changes from Revision C (August 2014) to Revision D	Page
--	-------------

• Added the bq771815 device to Production Data.....	3
• Changed the <i>Handling Ratings</i> table	5
• Added bq771817 to the V_{OV} <i>DC Characteristics</i>	6
• Added note to the <i>Application and Implementation</i> section	12

Changes from Revision B (October 2013) to Revision C	Page
---	-------------

• Changed the data sheet format	1
• Added the bq771807 device to Production Data.....	3

Changes from Revision A (September 2013) to Revision B	Page
---	-------------

• Added the bq771809 device to Production Data.....	3
---	---

Changes from Original (December 2012) to Revision A	Page
--	-------------

• Added the bq771808 device to Production Data.....	3
---	---

5 Device Comparison Table

T_A	Part Number	Package	Package Designator	OVP (V)	OV Hysteresis (V)	Output Delay	Output Drive	Tape and Reel (Large)	Tape and Reel (Small)
-40°C to 110°C	bq771800	8-Pin QFN	DPJ	4.300	0.300	4 s	CMOS Active High	bq771800DPJR	bq771800DPJT
	bq771801			4.275	0.050	3 s	NCH Active Low, Open Drain	bq771801DPJR	bq771801DPJT
	bq771802			4.225	0.300	1 s	NCH Active Low, Open Drain	bq771802DPJR	bq771802DPJT
	bq771803			4.275	0.050	1 s	NCH Active Low, Open Drain	bq771803DPJR	bq771803DPJT
	bq771806			4.350	0.300	3 s	CMOS Active High	bq771806DPJR	bq771806DPJT
	bq771807			4.450	0.300	3 s	CMOS Active High	bq771807DPJR	bq771807DPJT
	bq771808			4.200	0.050	1 s	NCH Active Low	bq771808DPJR	bq771808DPJT
	bq771809			4.200	0.050	1 s	CMOS Active High	bq771809DPJR	bq771809DPJT
	bq771811 ⁽¹⁾			4.225	0.050	1 s	CMOS Active High	bq771811DPJR	bq771811DPJT
	bq771815			4.225	0.050	1 s	NCH Active Low	bq771815DPJR	bq771815DPJT
	bq771817			4.275	0.050	1 s	CMOS Active High	bq771817DPJR	bq771817DPJT
	bq771818 ⁽¹⁾			4.300	0.300	1 s	CMOS Active High	bq771818DPJR	bq771818DPJT
	bq771820 ⁽²⁾			4.190	0.300	1 s	NCH Active Low	bq771820DPJR	bq771820DPJT
bq7718xy ⁽³⁾	3.850 – 4.650	Latch, 0.05, 0.25, 0.3	1, 4, 3, 5.5 s	NCH, Active Low, Open Drain, CMOS Active High	bq7718xyDPJR	bq7718xyDPJT			

- (1) Contact TI for more information.
 (2) Advance information. Contact TI for more information.
 (3) Future option. Contact TI for more information.

6 Pin Configuration and Functions

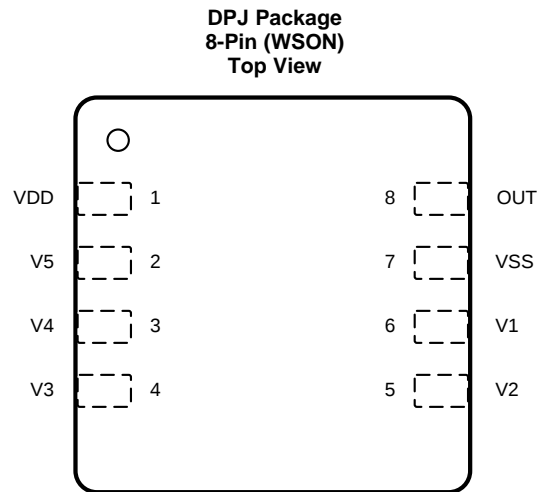

Pin Functions

NO.	NAME	TYPE I/O	DESCRIPTION
1	VDD	P	Power supply
2	V5	I	Sense input for positive voltage of the fifth cell from the bottom of the stack
3	V4	I	Sense input for positive voltage of the fourth cell from the bottom of the stack
4	V3	I	Sense input for positive voltage of the third cell from the bottom of the stack
5	V2	I	Sense input for positive voltage of the second cell from the bottom of the stack
6	V1	I	Sense input for positive voltage of the lowest cell in the stack
7	VSS	P	Electrically connected to IC ground and negative terminal of the lowest cell in the stack
8	OUT	O	Output drive for overvoltage fault signal

7 Specifications

7.1 Absolute Maximum Ratings

Over-operating free-air temperature range (unless otherwise noted)⁽¹⁾

		MIN	MAX	UNIT
Supply voltage range	VDD – VSS	–0.3	30	V
Input voltage range	V5 – VSS or V4 – VSS or V3 – VSS or V2 – VSS or V1 – VSS	–0.3	30	V
Output voltage range	OUT – VSS	–0.3	30	V
Continuous total power dissipation, P _{TOT}		See Thermal Information .		
Functional temperature		–40	110	°C
Storage temperature range, T _{STG}		–65	150	°C

(1) Stresses beyond those listed under “absolute maximum ratings” may cause permanent damage to the device. These are stress ratings only and functional operation of the device at these or any other conditions beyond those indicated under “recommended operating conditions” is not implied. Exposure to absolute-maximum-rated conditions for extended periods may affect device reliability.

7.2 ESD Ratings

			VALUE	UNIT
V _(ESD) Rating	Electrostatic discharge	Human body model (HBM) ESD stress voltage ⁽¹⁾	±2000	V
		Charged device model (CDM) ESD stress voltage ⁽²⁾	±500	

(1) JEDEC document JEP155 states that 500-V HBM allows safe manufacturing with a standard ESD control process.

(2) JEDEC document JEP157 states that 250-V CDM allows safe manufacturing with a standard ESD control process.

7.3 Recommended Operating Conditions

Over-operating free-air temperature range (unless otherwise noted)

		MIN	MAX	UNIT
Supply voltage, V _{DD} ⁽¹⁾		3	25	V
Input voltage range	V5–V4 or V4–V3 or V3–V2 or V2–V1 or V1–VSS	0	5	V
Operating ambient temperature range, T _A		–40	110	°C

(1) See [Systems Examples](#).

7.4 Thermal Information

THERMAL METRIC ⁽¹⁾		bq7718xy		UNIT
		DPJ (WSON)		
		8 PINS		
R _{θJA}	Junction-to-ambient thermal resistance	56.6		°C/W
R _{θJctop}	Junction-to-case(top) thermal resistance	56.4		°C/W
R _{θJB}	Junction-to-board thermal resistance	30.6		°C/W
ψ _{JT}	Junction-to-top characterization parameter	1.0		°C/W
ψ _{JB}	Junction-to-board characterization parameter	37.8		°C/W
R _{θJcbot}	Junction-to-case(bottom) thermal resistance	11.3		°C/W

(1) For more information about traditional and new thermal metrics, see the [Semiconductor and IC Package Thermal Metrics](#) application report.

7.5 DC Characteristics

Typical values stated where $T_A = 25^\circ\text{C}$ and $V_{DD} = 18\text{ V}$, MIN/MAX values stated where $T_A = -40^\circ\text{C}$ to 110°C and $V_{DD} = 3\text{ V}$ to 25 V (unless otherwise noted).

SYMBOL	PARAMETER	CONDITION	MIN	TYP	MAX	UNIT
Voltage Protection Threshold VCx						
V_{OV}	$V_{I(\text{PROTECT})}$ Overvoltage Detection	bq771800		4.300		V
		bq771801		4.275		V
		bq771803		4.275		V
		bq771802		4.225		V
		bq771806		4.350		V
		bq771807		4.450		V
		bq771808		4.200		V
		bq771809		4.200		V
		bq771811 ⁽¹⁾		4.225		V
		bq771815		4.225		V
		bq771817		4.275		V
		bq771818 ⁽¹⁾		4.300		V
		bq771820 ⁽²⁾		4.190		V
V_{HYS}	OV Detection Hysteresis	bq771800	250	300	400	mV
		bq771801	0	50	100	mV
		bq771802	250	300	400	mV
		bq771803	0	50	100	mV
		bq771806	250	300	400	mV
		bq771807	250	300	400	mV
		bq771808	0	50	100	mV
		bq771809	0	50	100	mV
		bq771811 ⁽¹⁾	0	50	100	mV
		bq771815	0	50	100	mV
		bq771817	0	50	100	mV
		bq771818 ⁽¹⁾	250	300	400	mV
		bq771820 ⁽²⁾	250	300	400	mV
V_{OA}	OV Detection Accuracy	$T_A = 25^\circ\text{C}$	-10		10	mV
$V_{OADRIFT}$	OV Detection Accuracy Across Temperature	$T_A = -40^\circ\text{C}$	-40		44	mV
		$T_A = 0^\circ\text{C}$	-20		20	mV
		$T_A = 60^\circ\text{C}$	-24		24	mV
		$T_A = 110^\circ\text{C}$	-54		54	mV
Supply and Leakage Current						
I_{CC}	Supply Current	$(V_5-V_4) = (V_4-V_3) = (V_3-V_2) = (V_2-V_1) = (V_1-V_{SS}) = 4\text{ V}$ (See Figure 8.)		1	2	μA
I_{IN}	Input Current at V_x Pins	$(V_5-V_4) = (V_4-V_3) = (V_3-V_2) = (V_2-V_1) = (V_1-V_{SS}) = 4\text{ V}$ (See Figure 8.)	-0.1		0.1	μA
Output Drive OUT, CMOS Active HIGH Versions Only						
V_{OUT1}	Output Drive Voltage, Active High	(V_5-V_4) , (V_4-V_3) , (V_3-V_2) , (V_2-V_1) , or $(V_1-V_{SS}) > V_{OV}$, $V_{DD} = 18\text{ V}$, $I_{OH} = 100\ \mu\text{A}$	6			V
		If three of four cells are short circuited and only one cell remains powered and $> V_{OV}$, $V_{DD} = V_x$ (cell voltage), $I_{OH} = 100\ \mu\text{A}$		$V_{DD} - 0.3$		V
		(V_5-V_4) , (V_4-V_3) , (V_3-V_2) , (V_2-V_1) , and $(V_1-V_{SS}) < V_{OV}$, $V_{DD} = 18\text{ V}$, $I_{OL} = 100\ \mu\text{A}$ measured into pin		250	400	mV

(1) Contact TI for more information.

(2) Advance information. Contact TI for more information.

DC Characteristics (continued)

Typical values stated where $T_A = 25^\circ\text{C}$ and $V_{DD} = 18\text{ V}$, MIN/MAX values stated where $T_A = -40^\circ\text{C}$ to 110°C and $V_{DD} = 3\text{ V}$ to 25 V (unless otherwise noted).

SYMBOL	PARAMETER	CONDITION	MIN	TYP	MAX	UNIT
I_{OUTH1}	OUT Source Current (during OV)	(V5–V4), (V4–V3), (V3–V2), (V2–V1), or (V1–VSS) > V_{OV} , $V_{\text{DD}} = 18\text{ V}$, $\text{OUT} = 0\text{ V}$. Measured out of OUT pin			4.5	mA
I_{OUTL1}	OUT Sink Current (no OV)	(V5–V4), (V4–V3), (V3–V2), (V2–V1), and (V1–VSS) < V_{OV} , $V_{\text{DD}} = 18\text{ V}$, $\text{OUT} = V_{\text{DD}}$. Measured into OUT pin	0.5		14	mA
Output Drive OUT, NCH Open Drain Active LOW Versions Only						
V_{OUT2}	Output Drive Voltage, Active Low	(V5–V4), (V4–V3), (V3–V2), (V2–V1), or (V1–VSS) > V_{OV} , $V_{\text{DD}} = 18\text{ V}$, $I_{\text{OL}} = 100\ \mu\text{A}$ measured into OUT pin		250	400	mV
I_{OUTH2}	OUT Sink Current (during OV)	(V5–V4), (V4–V3), (V3–V2), (V2–V1), or (V1–VSS) > V_{OV} , $V_{\text{DD}} = 18\text{ V}$, $\text{OUT} = V_{\text{DD}}$. Measured into OUT pin	0.5		14	mA
I_{OUTL2}	OUT Source Current (no OV)	(V5–V4), (V4–V3), (V3–V2), (V2–V1), and (V1–VSS) < V_{OV} , $V_{\text{DD}} = 18\text{ V}$, $\text{OUT} = V_{\text{DD}}$. Measured out of OUT pin			100	nA

7.6 Timing Requirements

		MIN	NOM	MAX	UNIT	
Delay Timer						
t_{DELAY}	OV Delay Time	bq771800	3.2	4	4.8	s
		bq771801, bq771807, bq771819	2.4	3	3.6	s
		bq771802, bq771803, bq771811 ⁽¹⁾ , bq771815, bq771818 ⁽¹⁾ , bq771820 ⁽²⁾	0.8	1	1.2	s
		Preview option only. Contact TI.	4.4	5.5	6.6	s
X_{CTMDELAY}	Fault Detection Delay Time during Customer Test Mode	See Customer Test Mode .		15	ms	

(1) Contact TI for more information.

(2) Advance information. Contact TI for more information.

7.7 Typical Characteristics

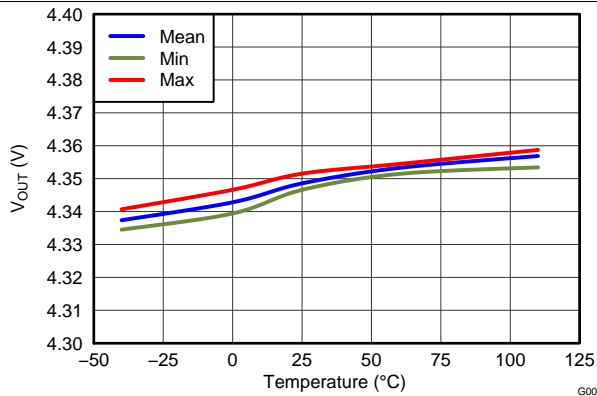

Figure 1. Overvoltage Threshold (OVT) vs. Temperature

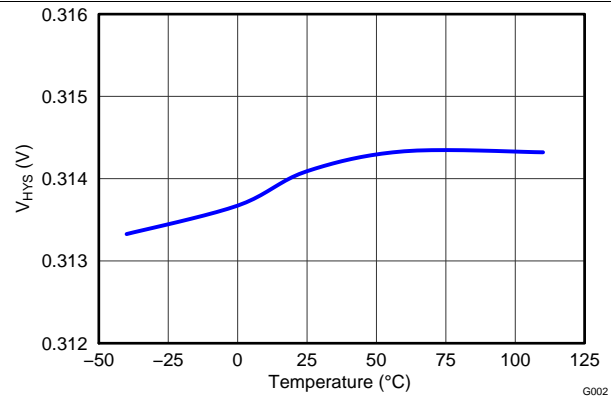

Figure 2. Hysteresis V_{HYS} vs. Temperature

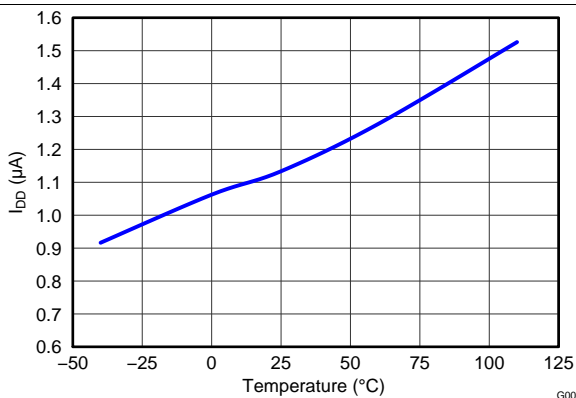

Figure 3. I_{DD} Current Consumption vs. Temperature at $V_{DD} = 16$ V

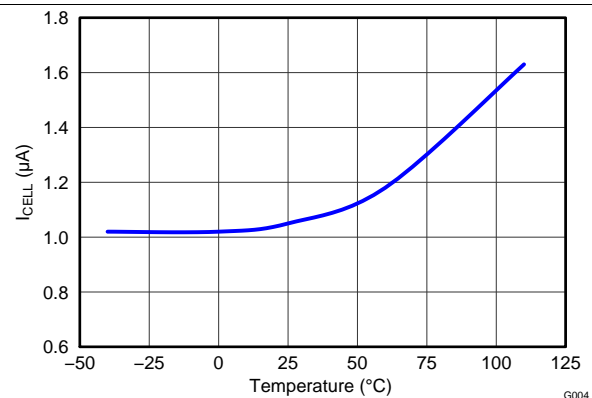

Figure 4. I_{CELL} vs. Temperature at $V_{CELL} = 9.2$ V

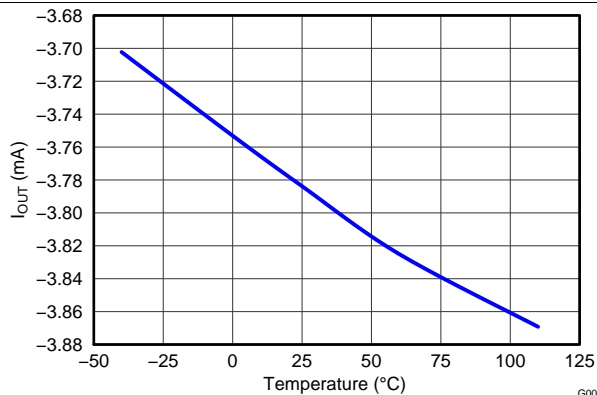

Figure 5. Output Current I_{OUT} vs. Temperature

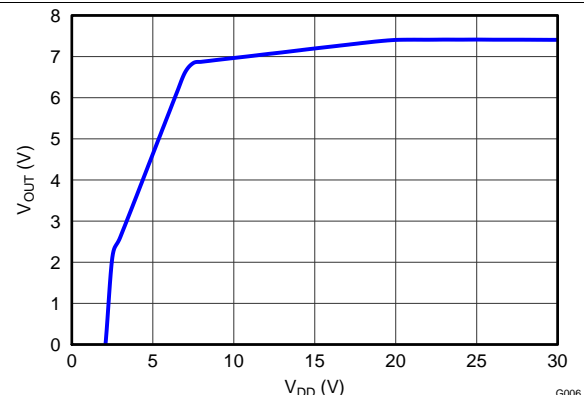

Figure 6. V_{OUT} vs. V_{DD}

8 Detailed Description

8.1 Overview

In the bq7718xy family of devices, each cell is monitored independently and an external delay timer is initiated if an overvoltage condition is detected on any cell.

For quicker production-line testing, the device provides a Customer Test Mode with greatly reduced delay time.

8.2 Functional Block Diagram

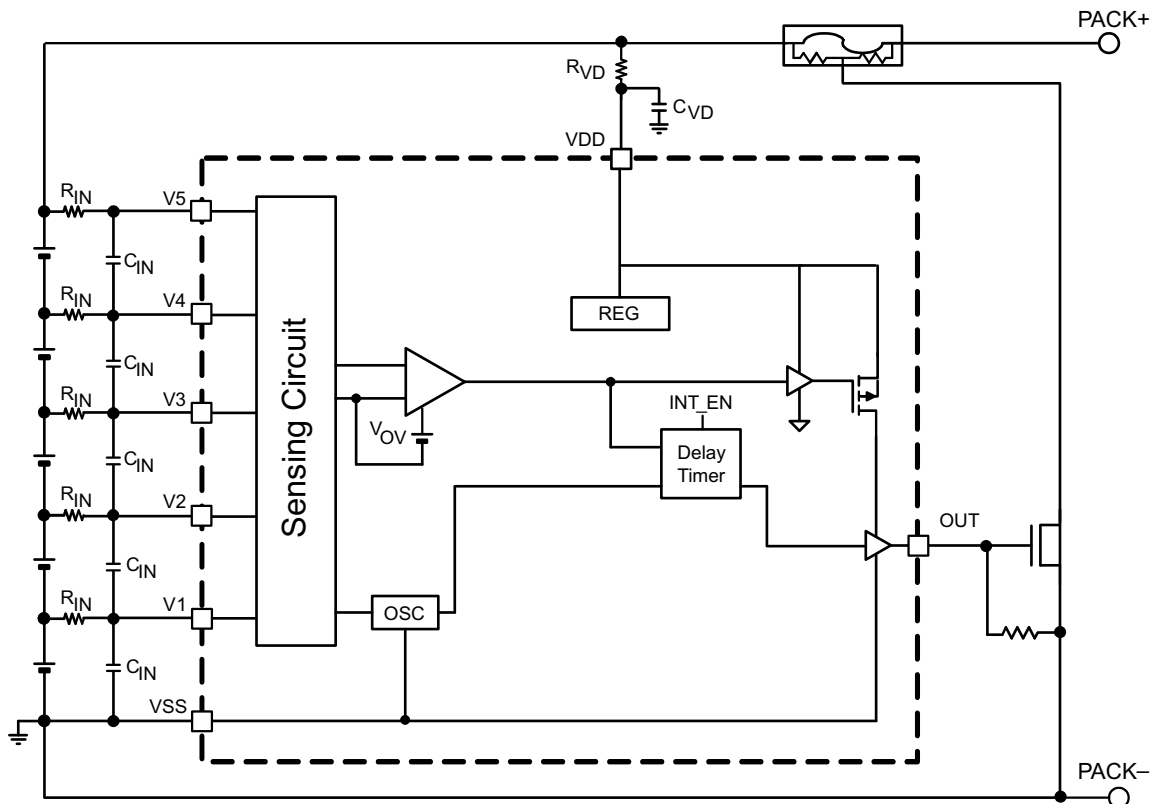

Copyright © 2016, Texas Instruments Incorporated

8.3 Feature Description

In the bq7718xy device, each cell is monitored independently. Overvoltage is detected by comparing the actual cell voltage to a protection voltage reference, V_{OV} . If any cell voltage exceeds the programmed OV value, a timer circuit is activated. When the timer expires, the OUT pin goes from inactive to active state.

For NCH Open Drain Active Low configurations, the OUT pin pulls down to VSS when active (OV present) and is high impedance when inactive (no OV).

Feature Description (continued)

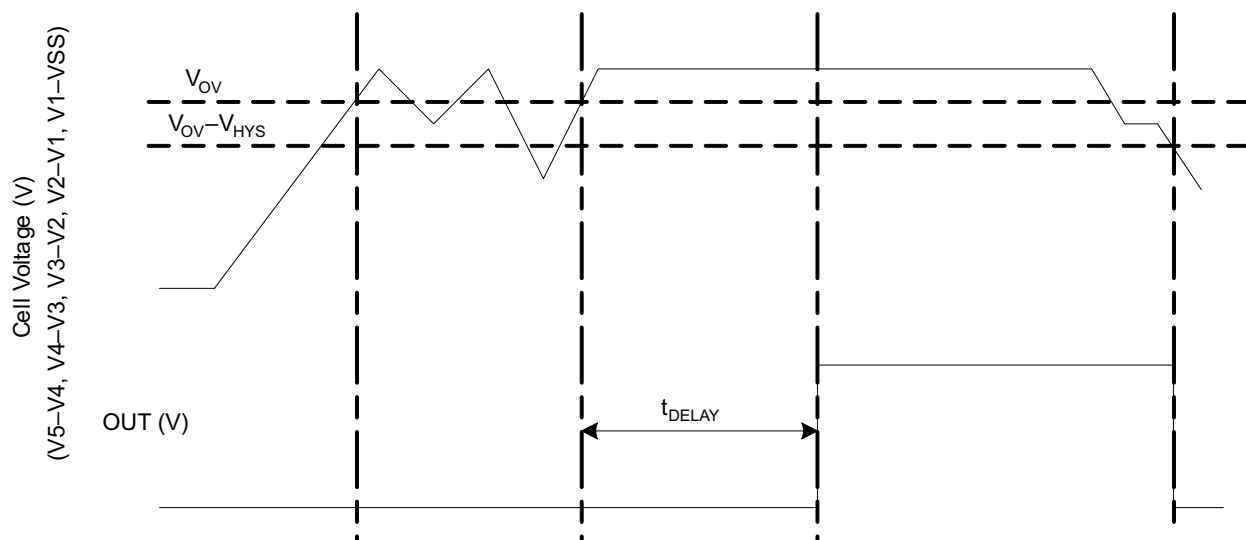

Figure 7. Timing for Overvoltage Sensing

8.3.1 Sense Positive Input for V_x

This is an input to sense each single battery cell voltage. A series resistor and a capacitor across the cell for each input is required for noise filtering and stable voltage monitoring.

8.3.2 Output Drive, OUT

This pin serves as the fault signal output, and may be ordered in either active HIGH or LOW options.

8.3.3 Supply Input, VDD

This pin is the unregulated input power source for the IC. A series resistor is connected to limit the current, and a capacitor is connected to ground for noise filtering.

8.4 Device Functional Modes

8.4.1 NORMAL Mode

When all of the cell voltages are below the overvoltage threshold, V_{OV} , the device operates in NORMAL mode. The device monitors the differential cell voltages connected across (V1 – VSS), (V2 – V1), (V3 – V2), (V4 – V3), and (VC4 – VC5). The OUT pin is inactive and if configured:

The OUT pin is inactive and if configured:

- Active high is low.
- Active low is being externally pulled up and is an open drain.

8.4.2 OVERVOLTAGE Mode

OVERVOLTAGE mode is detected if any of the cell voltages exceeds the overvoltage threshold, V_{OV} for configured OV delay time. The OUT pin is activated after a delay time set by the capacitance in the CD pin. The OUT pin will either pull high internally, if configured as active high, or will be pulled low internally, if configured as active low. When all of the cell voltages fall below the $(V_{OV} - V_{HYS})$, the device returns to NORMAL mode.

Device Functional Modes (continued)

8.4.3 Customer Test Mode

Customer Test Mode (CTM) helps to reduce test time for checking the overvoltage delay timer parameter once the circuit is implemented in the battery pack. To enter CTM, VDD should be set to at least 10 V higher than V5 (see Figure 8). The delay timer is greater than 10 ms, but considerably shorter than the timer delay in normal operation. To exit Customer Test Mode, remove the VDD to a V5 voltage differential of 10 V so that the decrease in this value automatically causes an exit.

CAUTION

Avoid exceeding any Absolute Maximum Voltages on any pins when placing the part into Customer Test Mode. Also avoid exceeding Absolute Maximum Voltages for the individual cell voltages (V5–V4), (V4–V3), (V4–V3), (V3–V2), (V2–V1), and (V1–VSS). Stressing the pins beyond the rated limits may cause permanent damage to the device.

Figure 8 shows the timing for the Customer Test Mode.

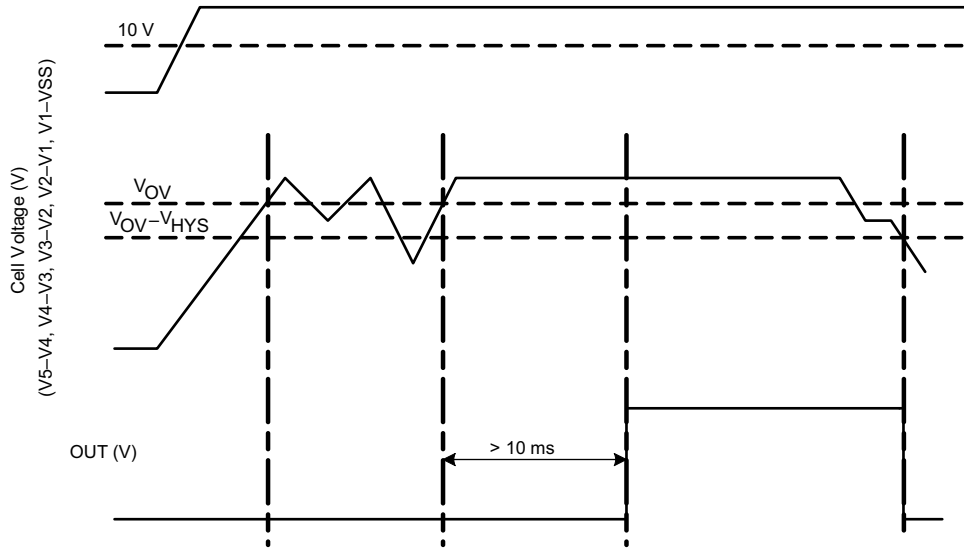

Figure 8. Timing for Customer Test Mode

9 Application and Implementation

NOTE

Information in the following applications sections is not part of the TI component specification, and TI does not warrant its accuracy or completeness. TI's customers are responsible for determining suitability of components for their purposes. Customers should validate and test their design implementation to confirm system functionality.

9.1 Application Information

In the case of an Open Drain Active Low configuration, an external pull-up resistor is required on the OUT pin. Changes to the ranges stated in Table 1 will impact the accuracy of the cell measurements.

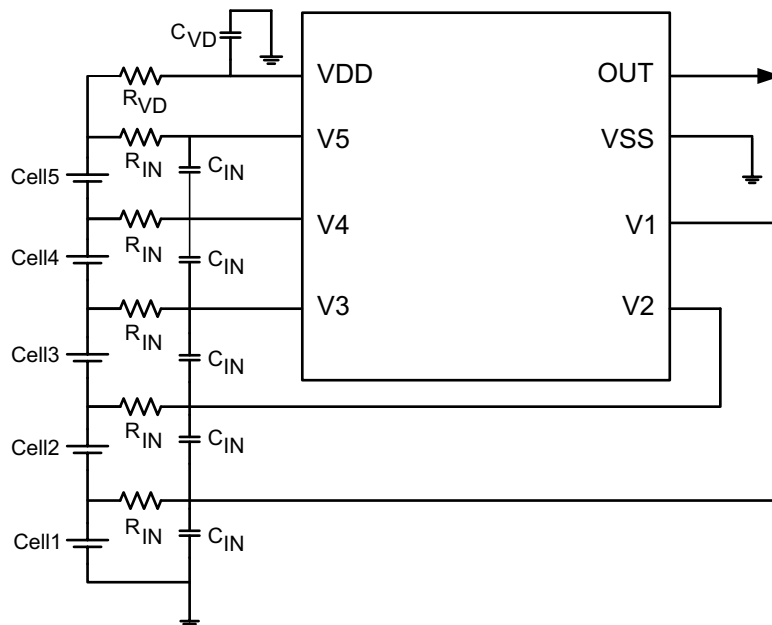

Copyright © 2016, Texas Instruments Incorporated

Figure 9. Application Configuration

9.1.1 Design Requirements

Changes to the ranges stated in Table 1 will impact the accuracy of the cell measurements. Figure 9 shows each external component.

Table 1. Parameters

PARAMETER	EXTERNAL COMPONENT	MIN	NOM	MAX	UNIT
Voltage monitor filter resistance	R_{IN}	900	1000	1100	Ω
Voltage monitor filter capacitance	C_{IN}	0.01		0.1	μF
Supply voltage filter resistance	R_{VD}	100		1K	Ω
Supply voltage filter capacitance	C_{VD}		0.1		μF
CD external delay capacitance			0.1	1	μF
OUT Open drain version pull-up resistance to PACK+			100		k Ω

NOTE

The device is calibrated using an R_{IN} value = 1 k Ω . Using a value other than this recommended value changes the accuracy of the cell voltage measurements and V_{OV} trigger level.

9.1.2 Detailed Design Procedure

Figure 10 shows the measurement for current consumption for the product for both VDD and V_x .

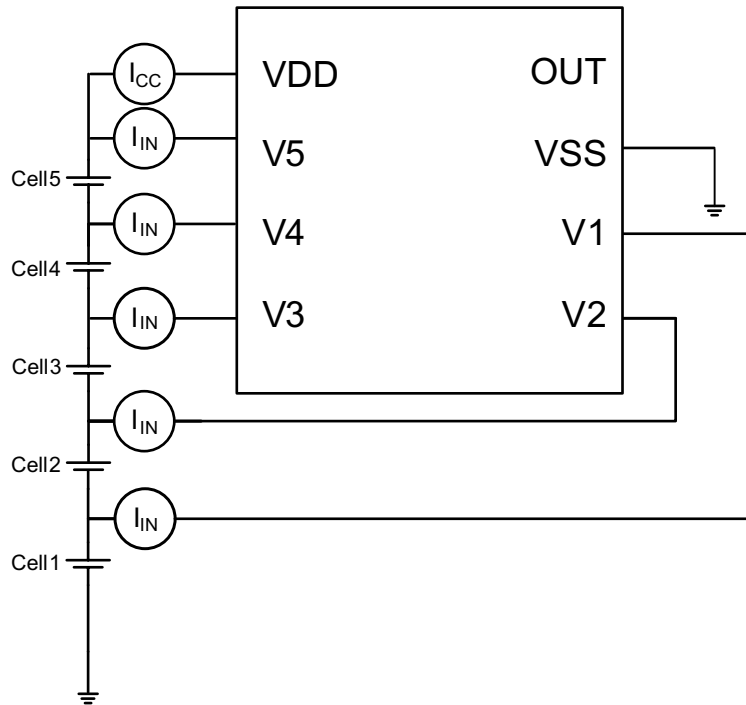

Copyright © 2016, Texas Instruments Incorporated

Figure 10. Configuration for IC Current Consumption Test

9.1.2.1 Application Curves

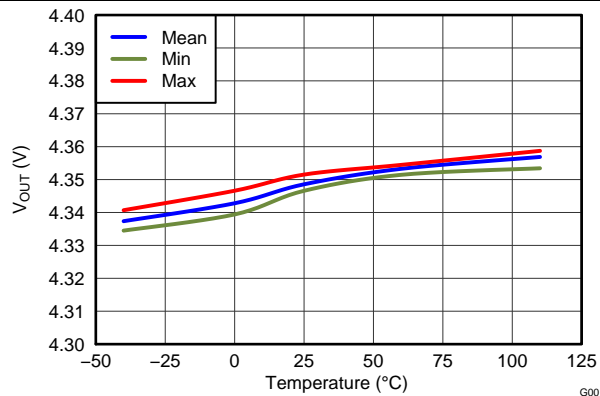

Figure 11. Overvoltage Threshold (OVT) vs. Temperature

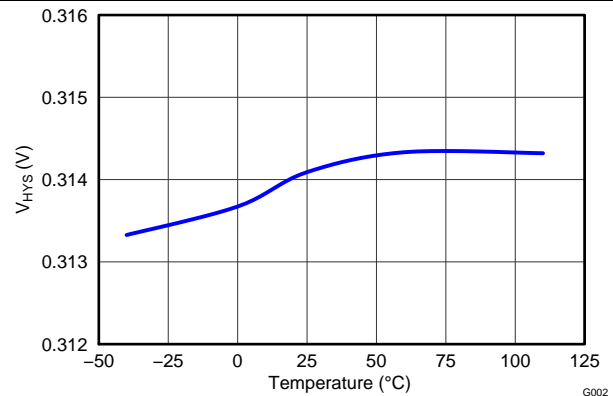

Figure 12. Hysteresis V_{HYS} vs. Temperature

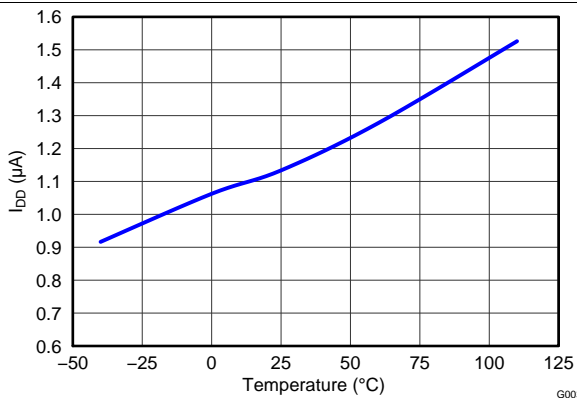

Figure 13. I_{DD} Current Consumption vs. Temperature at $V_{DD} = 16$ V

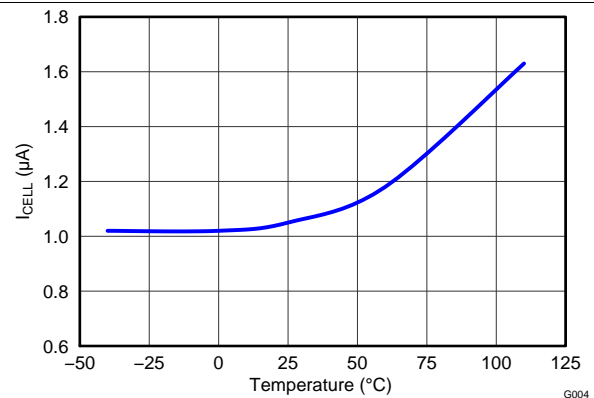

Figure 14. I_{CELL} vs. Temperature at $V_{CELL} = 9.2$ V

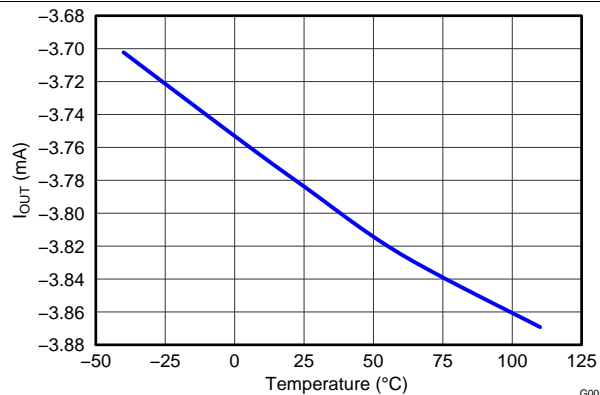

Figure 15. Output Current I_{OUT} vs. Temperature

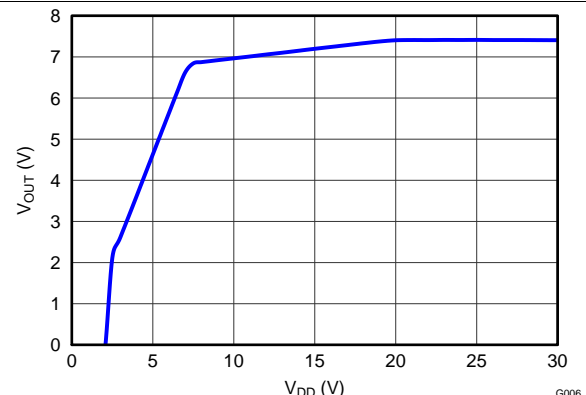
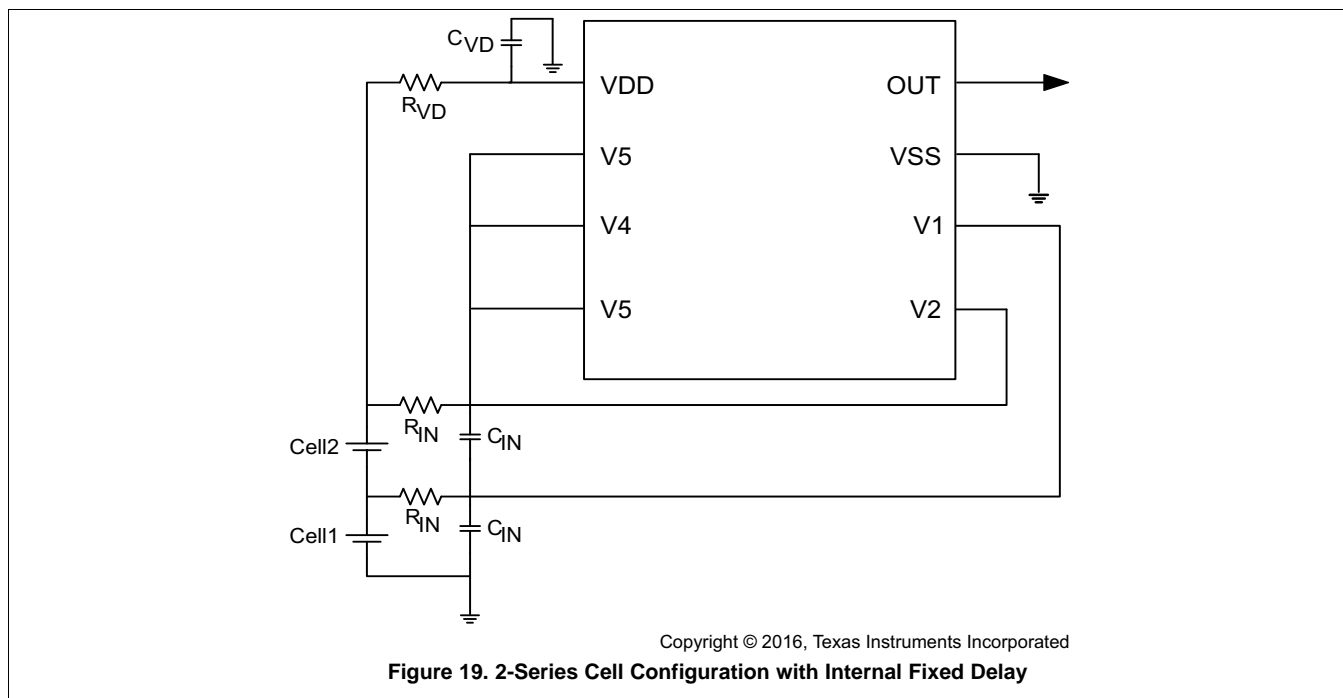
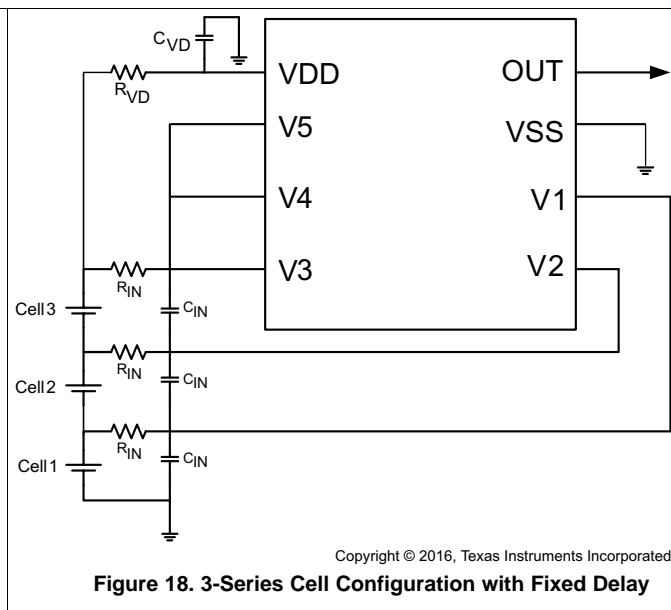
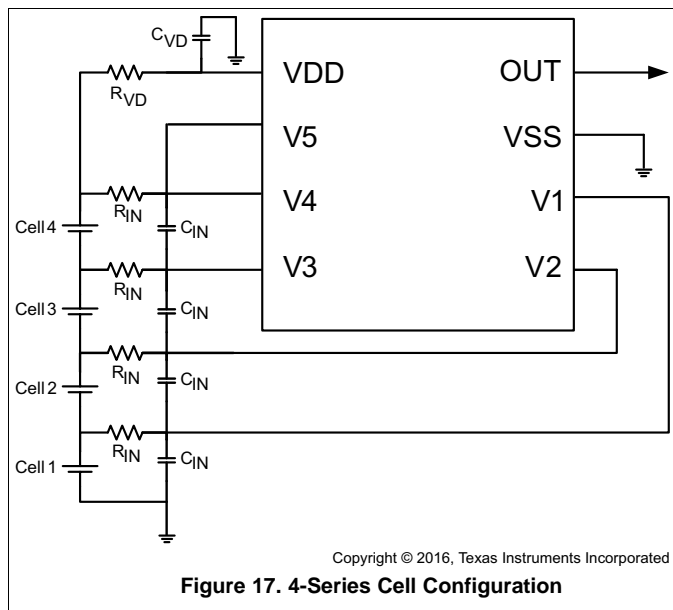

Figure 16. V_{OUT} vs. V_{DD}

9.2 Systems Examples

In these application examples, an external pull-up resistor is required on the OUT pin to configure for an Open Drain Active Low operation.



10 Power Supply Recommendations

The maximum power of this device is 25 V on VDD.

11 Layout

11.1 Layout Guidelines

- Ensure the RC filters for the V1 and VDD pins are placed as close as possible to the target terminal.
- The VSS pin should be routed to the CELL– terminal.

11.2 Layout Example

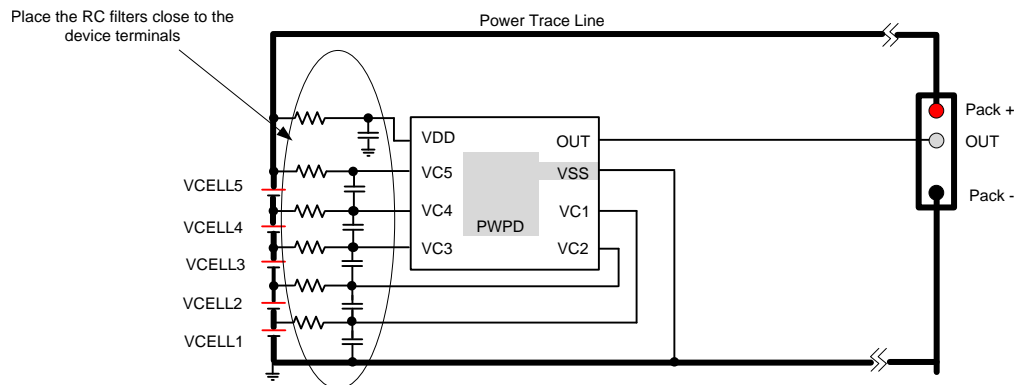

Figure 20. Example Layout

12 Device and Documentation Support

12.1 Related Links

The table below lists quick access links. Categories include technical documents, support and community resources, tools and software, and quick access to order now.

Table 2. Related Links

PARTS	PRODUCT FOLDER	ORDER NOW	TECHNICAL DOCUMENTS	TOOLS & SOFTWARE	SUPPORT & COMMUNITY
bq7718	Click here	Click here	Click here	Click here	Click here
bq771800	Click here	Click here	Click here	Click here	Click here
bq771801	Click here	Click here	Click here	Click here	Click here
bq771802	Click here	Click here	Click here	Click here	Click here
bq771803	Click here	Click here	Click here	Click here	Click here
bq771806	Click here	Click here	Click here	Click here	Click here
bq771807	Click here	Click here	Click here	Click here	Click here
bq771808	Click here	Click here	Click here	Click here	Click here
bq771809	Click here	Click here	Click here	Click here	Click here
bq771815	Click here	Click here	Click here	Click here	Click here
bq771817	Click here	Click here	Click here	Click here	Click here

12.2 Receiving Notification of Documentation Updates

To receive notification of documentation updates, navigate to the device product folder on ti.com. In the upper right corner, click on *Alert me* to register and receive a weekly digest of any product information that has changed. For change details, review the revision history included in any revised document.

12.3 Community Resources

The following links connect to TI community resources. Linked contents are provided "AS IS" by the respective contributors. They do not constitute TI specifications and do not necessarily reflect TI's views; see TI's [Terms of Use](#).

TI E2E™ Online Community *TI's Engineer-to-Engineer (E2E) Community*. Created to foster collaboration among engineers. At e2e.ti.com, you can ask questions, share knowledge, explore ideas and help solve problems with fellow engineers.

Design Support *TI's Design Support* Quickly find helpful E2E forums along with design support tools and contact information for technical support.

12.4 Trademarks

E2E is a trademark of Texas Instruments.
All other trademarks are the property of their respective owners.

12.5 Electrostatic Discharge Caution



This integrated circuit can be damaged by ESD. Texas Instruments recommends that all integrated circuits be handled with appropriate precautions. Failure to observe proper handling and installation procedures can cause damage.

ESD damage can range from subtle performance degradation to complete device failure. Precision integrated circuits may be more susceptible to damage because very small parametric changes could cause the device not to meet its published specifications.

12.6 Glossary

SLYZ022 — *TI Glossary*.

This glossary lists and explains terms, acronyms, and definitions.

13 Mechanical, Packaging, and Orderable Information

The following pages include mechanical, packaging, and orderable information. This information is the most current data available for the designated devices. This data is subject to change without notice and revision of this document. For browser-based versions of this data sheet, refer to the left-hand navigation.

PACKAGING INFORMATION

Orderable Device	Status (1)	Package Type	Package Drawing	Pins	Package Qty	Eco Plan (2)	Lead/Ball Finish (6)	MSL Peak Temp (3)	Op Temp (°C)	Device Marking (4/5)	Samples
BQ771800DPJR	ACTIVE	WSO	DPJ	8	3000	Green (RoHS & no Sb/Br)	CU NIPDAU	Level-2-260C-1 YEAR	-40 to 85	771800	Samples
BQ771800DPJT	ACTIVE	WSO	DPJ	8	250	Green (RoHS & no Sb/Br)	CU NIPDAU	Level-2-260C-1 YEAR	-40 to 85	771800	Samples
BQ771801DPJR	ACTIVE	WSO	DPJ	8	3000	Green (RoHS & no Sb/Br)	CU NIPDAU	Level-2-260C-1 YEAR	-40 to 85	771801	Samples
BQ771801DPJT	ACTIVE	WSO	DPJ	8	250	Green (RoHS & no Sb/Br)	CU NIPDAU	Level-2-260C-1 YEAR	-40 to 85	771801	Samples
BQ771802DPJR	ACTIVE	WSO	DPJ	8	3000	Green (RoHS & no Sb/Br)	CU NIPDAU	Level-2-260C-1 YEAR	-40 to 85	771802	Samples
BQ771802DPJT	ACTIVE	WSO	DPJ	8	250	Green (RoHS & no Sb/Br)	CU NIPDAU	Level-2-260C-1 YEAR	-40 to 85	771802	Samples
BQ771803DPJR	ACTIVE	WSO	DPJ	8	3000	Green (RoHS & no Sb/Br)	CU NIPDAU	Level-2-260C-1 YEAR	-40 to 85	771803	Samples
BQ771803DPJT	ACTIVE	WSO	DPJ	8	250	Green (RoHS & no Sb/Br)	CU NIPDAU	Level-2-260C-1 YEAR	-40 to 85	771803	Samples
BQ771806DPJR	ACTIVE	WSO	DPJ	8	3000	Green (RoHS & no Sb/Br)	CU NIPDAU	Level-2-260C-1 YEAR	-40 to 85	771806	Samples
BQ771806DPJT	ACTIVE	WSO	DPJ	8	250	Green (RoHS & no Sb/Br)	CU NIPDAU	Level-2-260C-1 YEAR	-40 to 85	771806	Samples
BQ771807DPJR	ACTIVE	WSO	DPJ	8	3000	Green (RoHS & no Sb/Br)	CU NIPDAU	Level-2-260C-1 YEAR	-40 to 85	771807	Samples
BQ771807DPJT	ACTIVE	WSO	DPJ	8	250	Green (RoHS & no Sb/Br)	CU NIPDAU	Level-2-260C-1 YEAR	-40 to 85	771807	Samples
BQ771808DPJR	ACTIVE	WSO	DPJ	8	3000	Green (RoHS & no Sb/Br)	CU NIPDAU	Level-2-260C-1 YEAR	-40 to 85	771808	Samples
BQ771808DPJT	ACTIVE	WSO	DPJ	8	250	Green (RoHS & no Sb/Br)	CU NIPDAU	Level-2-260C-1 YEAR	-40 to 85	771808	Samples
BQ771809DPJR	ACTIVE	WSO	DPJ	8	3000	Green (RoHS & no Sb/Br)	CU NIPDAU	Level-2-260C-1 YEAR	-40 to 85	771809	Samples
BQ771809DPJT	ACTIVE	WSO	DPJ	8	250	Green (RoHS & no Sb/Br)	CU NIPDAU	Level-2-260C-1 YEAR	-40 to 85	771809	Samples
BQ771815DPJR	ACTIVE	WSO	DPJ	8	3000	Green (RoHS & no Sb/Br)	CU NIPDAU	Level-2-260C-1 YEAR	-40 to 85	771815	Samples

Orderable Device	Status (1)	Package Type	Package Drawing	Pins	Package Qty	Eco Plan (2)	Lead/Ball Finish (6)	MSL Peak Temp (3)	Op Temp (°C)	Device Marking (4/5)	Samples
BQ771815DPJT	ACTIVE	WSON	DPJ	8	250	Green (RoHS & no Sb/Br)	CU NIPDAU	Level-2-260C-1 YEAR	-40 to 85	771815	Samples
BQ771817DPJR	ACTIVE	WSON	DPJ	8	3000	Green (RoHS & no Sb/Br)	CU NIPDAU	Level-2-260C-1 YEAR	-40 to 85	771817	Samples
BQ771817DPJT	ACTIVE	WSON	DPJ	8	250	Green (RoHS & no Sb/Br)	CU NIPDAU	Level-2-260C-1 YEAR	-40 to 85	771817	Samples

(1) The marketing status values are defined as follows:

ACTIVE: Product device recommended for new designs.

LIFEBUY: TI has announced that the device will be discontinued, and a lifetime-buy period is in effect.

NRND: Not recommended for new designs. Device is in production to support existing customers, but TI does not recommend using this part in a new design.

PREVIEW: Device has been announced but is not in production. Samples may or may not be available.

OBsolete: TI has discontinued the production of the device.

(2) **RoHS:** TI defines "RoHS" to mean semiconductor products that are compliant with the current EU RoHS requirements for all 10 RoHS substances, including the requirement that RoHS substance do not exceed 0.1% by weight in homogeneous materials. Where designed to be soldered at high temperatures, "RoHS" products are suitable for use in specified lead-free processes. TI may reference these types of products as "Pb-Free".

RoHS Exempt: TI defines "RoHS Exempt" to mean products that contain lead but are compliant with EU RoHS pursuant to a specific EU RoHS exemption.

Green: TI defines "Green" to mean the content of Chlorine (Cl) and Bromine (Br) based flame retardants meet JS709B low halogen requirements of <=1000ppm threshold. Antimony trioxide based flame retardants must also meet the <=1000ppm threshold requirement.

(3) MSL, Peak Temp. - The Moisture Sensitivity Level rating according to the JEDEC industry standard classifications, and peak solder temperature.

(4) There may be additional marking, which relates to the logo, the lot trace code information, or the environmental category on the device.

(5) Multiple Device Markings will be inside parentheses. Only one Device Marking contained in parentheses and separated by a "~" will appear on a device. If a line is indented then it is a continuation of the previous line and the two combined represent the entire Device Marking for that device.

(6) Lead/Ball Finish - Orderable Devices may have multiple material finish options. Finish options are separated by a vertical ruled line. Lead/Ball Finish values may wrap to two lines if the finish value exceeds the maximum column width.

Important Information and Disclaimer:The information provided on this page represents TI's knowledge and belief as of the date that it is provided. TI bases its knowledge and belief on information provided by third parties, and makes no representation or warranty as to the accuracy of such information. Efforts are underway to better integrate information from third parties. TI has taken and continues to take reasonable steps to provide representative and accurate information but may not have conducted destructive testing or chemical analysis on incoming materials and chemicals. TI and TI suppliers consider certain information to be proprietary, and thus CAS numbers and other limited information may not be available for release.

In no event shall TI's liability arising out of such information exceed the total purchase price of the TI part(s) at issue in this document sold by TI to Customer on an annual basis.

TAPE AND REEL INFORMATION

QUADRANT ASSIGNMENTS FOR PIN 1 ORIENTATION IN TAPE

*All dimensions are nominal

Device	Package Type	Package Drawing	Pins	SPQ	Reel Diameter (mm)	Reel Width W1 (mm)	A0 (mm)	B0 (mm)	K0 (mm)	P1 (mm)	W (mm)	Pin1 Quadrant
BQ771800DPJR	WSON	DPJ	8	3000	330.0	12.4	3.3	4.3	1.1	8.0	12.0	Q2
BQ771800DPJT	WSON	DPJ	8	250	180.0	12.4	3.3	4.3	1.1	8.0	12.0	Q2
BQ771801DPJR	WSON	DPJ	8	3000	330.0	12.4	3.3	4.3	1.1	8.0	12.0	Q2
BQ771801DPJT	WSON	DPJ	8	250	180.0	12.4	3.3	4.3	1.1	8.0	12.0	Q2
BQ771802DPJR	WSON	DPJ	8	3000	330.0	12.4	3.3	4.3	1.1	8.0	12.0	Q2
BQ771802DPJT	WSON	DPJ	8	250	180.0	12.4	3.3	4.3	1.1	8.0	12.0	Q2
BQ771803DPJR	WSON	DPJ	8	3000	330.0	12.4	3.3	4.3	1.1	8.0	12.0	Q2
BQ771803DPJT	WSON	DPJ	8	250	180.0	12.4	3.3	4.3	1.1	8.0	12.0	Q2
BQ771806DPJR	WSON	DPJ	8	3000	330.0	12.4	3.3	4.3	1.1	8.0	12.0	Q2
BQ771806DPJT	WSON	DPJ	8	250	180.0	12.4	3.3	4.3	1.1	8.0	12.0	Q2
BQ771807DPJR	WSON	DPJ	8	3000	330.0	12.4	3.3	4.3	1.1	8.0	12.0	Q2
BQ771807DPJT	WSON	DPJ	8	250	180.0	12.4	3.3	4.3	1.1	8.0	12.0	Q2
BQ771808DPJR	WSON	DPJ	8	3000	330.0	12.4	3.3	4.3	1.1	8.0	12.0	Q2
BQ771808DPJT	WSON	DPJ	8	250	180.0	12.4	3.3	4.3	1.1	8.0	12.0	Q2
BQ771809DPJR	WSON	DPJ	8	3000	330.0	12.4	3.3	4.3	1.1	8.0	12.0	Q2
BQ771809DPJT	WSON	DPJ	8	250	180.0	12.4	3.3	4.3	1.1	8.0	12.0	Q2
BQ771815DPJR	WSON	DPJ	8	3000	330.0	12.4	3.3	4.3	1.1	8.0	12.0	Q2
BQ771815DPJT	WSON	DPJ	8	250	180.0	12.4	3.3	4.3	1.1	8.0	12.0	Q2

Device	Package Type	Package Drawing	Pins	SPQ	Reel Diameter (mm)	Reel Width W1 (mm)	A0 (mm)	B0 (mm)	K0 (mm)	P1 (mm)	W (mm)	Pin1 Quadrant
BQ771817DPJR	WSON	DPJ	8	3000	330.0	12.4	3.3	4.3	1.1	8.0	12.0	Q2
BQ771817DPJT	WSON	DPJ	8	250	180.0	12.4	3.3	4.3	1.1	8.0	12.0	Q2

TAPE AND REEL BOX DIMENSIONS

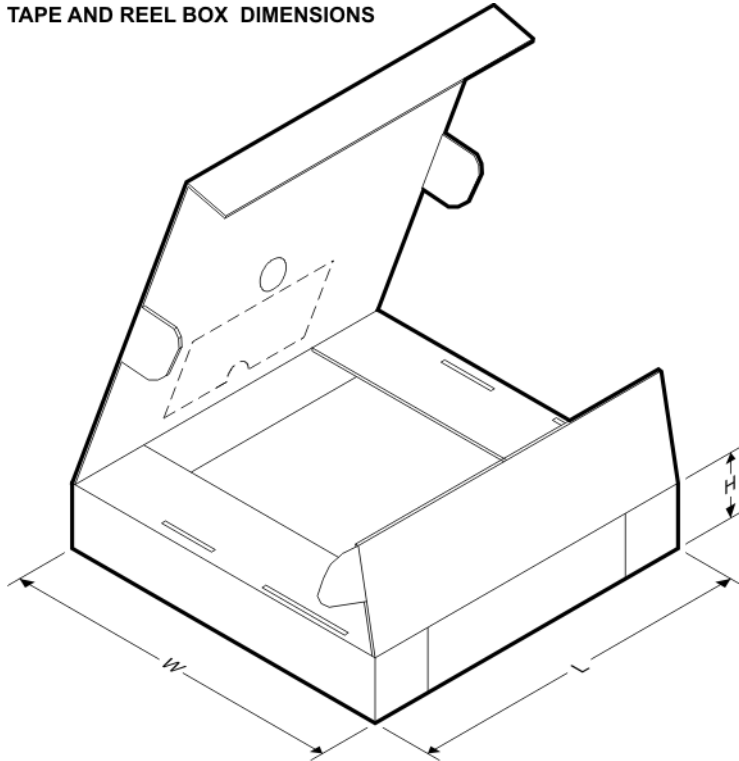

*All dimensions are nominal

Device	Package Type	Package Drawing	Pins	SPQ	Length (mm)	Width (mm)	Height (mm)
BQ771800DPJR	WSON	DPJ	8	3000	367.0	367.0	35.0
BQ771800DPJT	WSON	DPJ	8	250	210.0	185.0	35.0
BQ771801DPJR	WSON	DPJ	8	3000	367.0	367.0	35.0
BQ771801DPJT	WSON	DPJ	8	250	210.0	185.0	35.0
BQ771802DPJR	WSON	DPJ	8	3000	367.0	367.0	35.0
BQ771802DPJT	WSON	DPJ	8	250	210.0	185.0	35.0
BQ771803DPJR	WSON	DPJ	8	3000	367.0	367.0	35.0
BQ771803DPJT	WSON	DPJ	8	250	210.0	185.0	35.0
BQ771806DPJR	WSON	DPJ	8	3000	367.0	367.0	35.0
BQ771806DPJT	WSON	DPJ	8	250	210.0	185.0	35.0
BQ771807DPJR	WSON	DPJ	8	3000	367.0	367.0	35.0
BQ771807DPJT	WSON	DPJ	8	250	210.0	185.0	35.0
BQ771808DPJR	WSON	DPJ	8	3000	367.0	367.0	35.0
BQ771808DPJT	WSON	DPJ	8	250	210.0	185.0	35.0
BQ771809DPJR	WSON	DPJ	8	3000	367.0	367.0	35.0

Device	Package Type	Package Drawing	Pins	SPQ	Length (mm)	Width (mm)	Height (mm)
BQ771809DPJT	WSON	DPJ	8	250	210.0	185.0	35.0
BQ771815DPJR	WSON	DPJ	8	3000	367.0	367.0	35.0
BQ771815DPJT	WSON	DPJ	8	250	210.0	185.0	35.0
BQ771817DPJR	WSON	DPJ	8	3000	367.0	367.0	35.0
BQ771817DPJT	WSON	DPJ	8	250	210.0	185.0	35.0

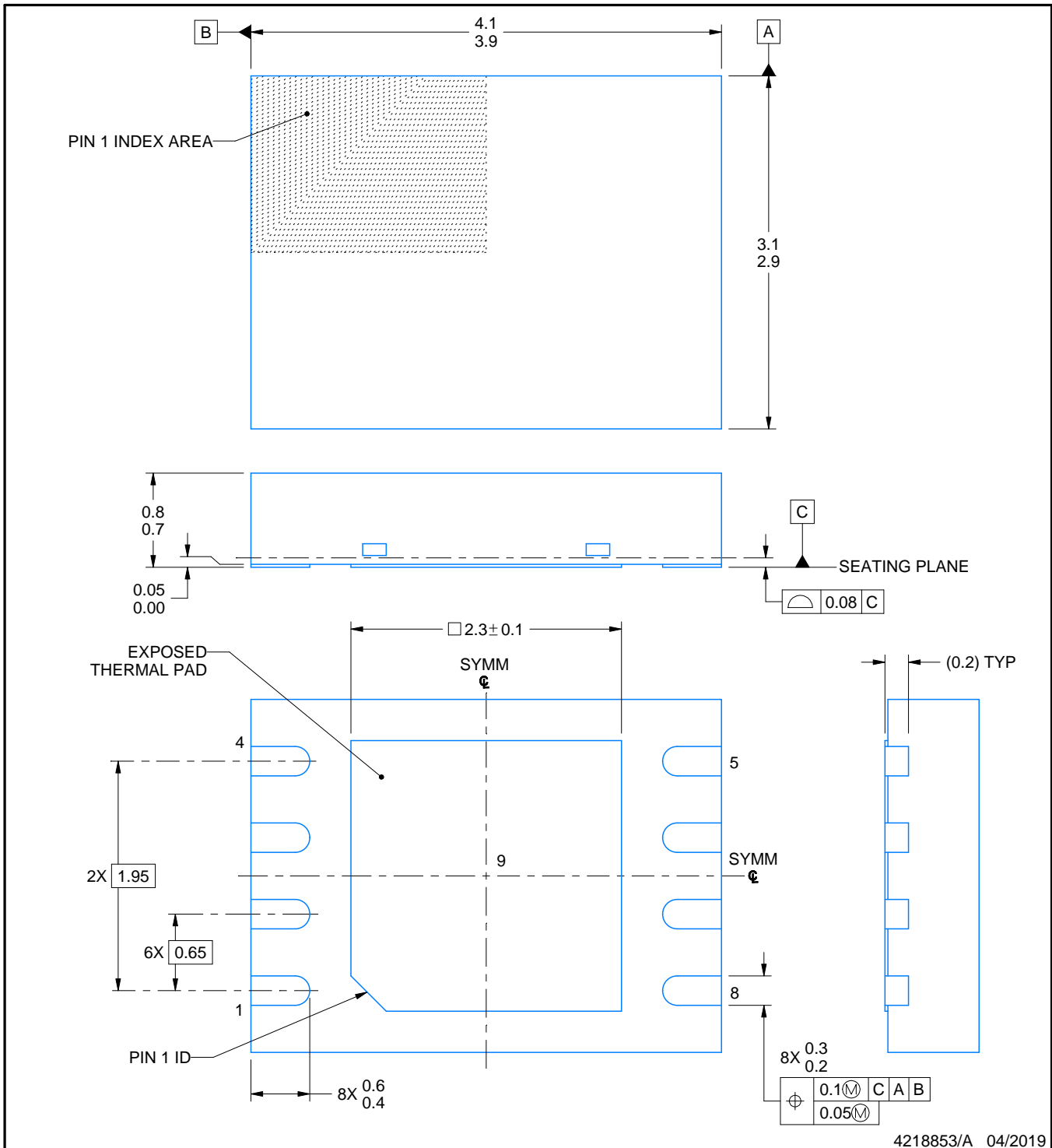
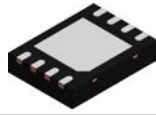

NOTES:

1. All linear dimensions are in millimeters. Any dimensions in parenthesis are for reference only. Dimensioning and tolerancing per ASME Y14.5M.
2. This drawing is subject to change without notice.
3. The package thermal pad must be soldered to the printed circuit board for thermal and mechanical performance.

EXAMPLE BOARD LAYOUT

DPJ0008A

WSON - 0.8 mm max height

PLASTIC SMALL OUTLINE - NO LEAD

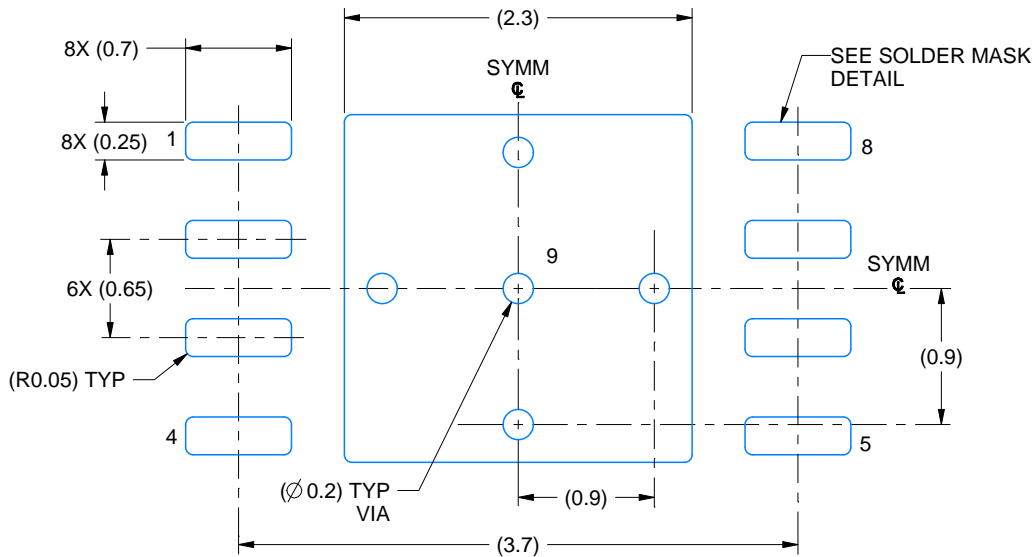

LAND PATTERN EXAMPLE
EXPOSED METAL SHOWN
SCALE: 20X

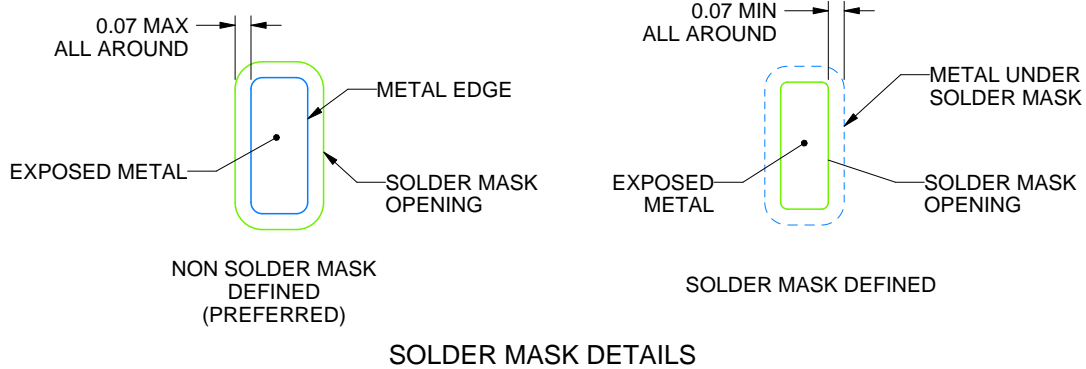

4218853/A 04/2019

NOTES: (continued)

- This package is designed to be soldered to a thermal pad on the board. For more information, see Texas Instruments literature number SLUA271 (www.ti.com/lit/slua271).
- Vias are optional depending on application, refer to device data sheet. If any vias are implemented, refer to their locations shown on this view. It is recommended that vias under paste be filled, plugged or tented.

EXAMPLE STENCIL DESIGN

DPJ0008A

WSON - 0.8 mm max height

PLASTIC SMALL OUTLINE - NO LEAD

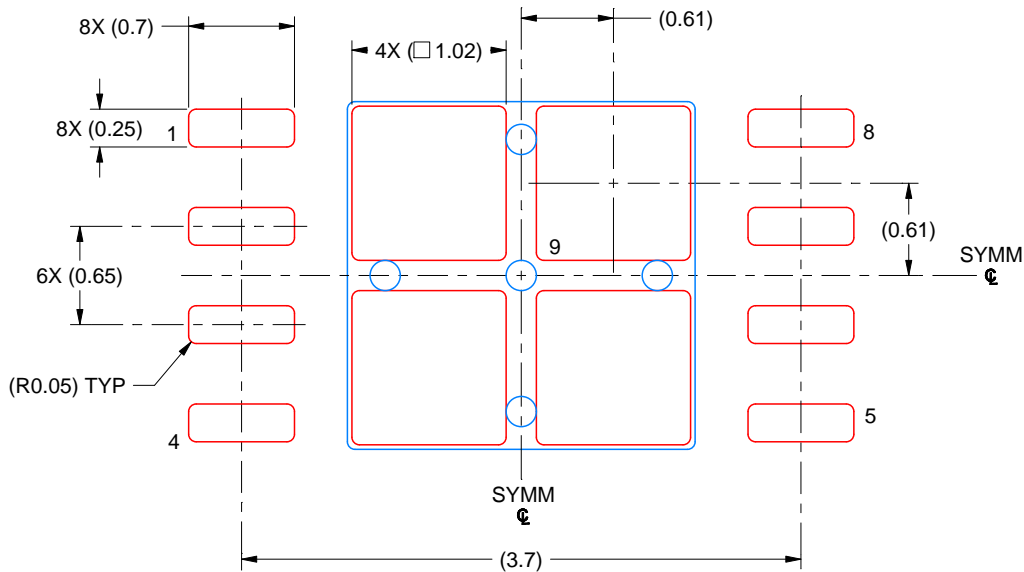

SOLDER PASTE EXAMPLE
BASED ON 0.125 MM THICK STENCIL
SCALE: 20X

EXPOSED PAD 9
79% PRINTED SOLDER COVERAGE BY AREA UNDER PACKAGE

4218853/A 04/2019

NOTES: (continued)

6. Laser cutting apertures with trapezoidal walls and rounded corners may offer better paste release. IPC-7525 may have alternate design recommendations.

IMPORTANT NOTICE AND DISCLAIMER

TI PROVIDES TECHNICAL AND RELIABILITY DATA (INCLUDING DATASHEETS), DESIGN RESOURCES (INCLUDING REFERENCE DESIGNS), APPLICATION OR OTHER DESIGN ADVICE, WEB TOOLS, SAFETY INFORMATION, AND OTHER RESOURCES "AS IS" AND WITH ALL FAULTS, AND DISCLAIMS ALL WARRANTIES, EXPRESS AND IMPLIED, INCLUDING WITHOUT LIMITATION ANY IMPLIED WARRANTIES OF MERCHANTABILITY, FITNESS FOR A PARTICULAR PURPOSE OR NON-INFRINGEMENT OF THIRD PARTY INTELLECTUAL PROPERTY RIGHTS.

These resources are intended for skilled developers designing with TI products. You are solely responsible for (1) selecting the appropriate TI products for your application, (2) designing, validating and testing your application, and (3) ensuring your application meets applicable standards, and any other safety, security, or other requirements. These resources are subject to change without notice. TI grants you permission to use these resources only for development of an application that uses the TI products described in the resource. Other reproduction and display of these resources is prohibited. No license is granted to any other TI intellectual property right or to any third party intellectual property right. TI disclaims responsibility for, and you will fully indemnify TI and its representatives against, any claims, damages, costs, losses, and liabilities arising out of your use of these resources.

TI's products are provided subject to TI's Terms of Sale (www.ti.com/legal/termsofsale.html) or other applicable terms available either on ti.com or provided in conjunction with such TI products. TI's provision of these resources does not expand or otherwise alter TI's applicable warranties or warranty disclaimers for TI products.

Mailing Address: Texas Instruments, Post Office Box 655303, Dallas, Texas 75265
Copyright © 2019, Texas Instruments Incorporated

Looking for pricing, stock, or lifecycle information?

Click below to explore more details on WIN SOURCE:

 [View BQ771808DPJT](#) on WIN SOURCE

 [Texas Instruments](#) Information

Optimize Your Supply Chain with WIN SOURCE Solutions

-  Global Sourcing Solution
-  Obsolete Management
-  Cost Control Management
-  Shortage Management
-  Alternative Solution
-  Excess Inventory Management