



**THE DATASHEET OF
BQ500100DCKT**



bq500100

20-V, High-Side Current Sensor for Wireless Charging

1 Features

- Wide Common-Mode Range: 0 V to 20 V
- Offset Voltage: $\pm 150 \mu\text{V}$ (Maximum)
 - Enables Shunt Drops of 10-mV Full-Scale
- Accuracy: $\pm 2\%$ Gain Error (Maximum Overtemperature)
- Fixed Gain: 50 V/V
- Low Quiescent Current: 100 μA (Maximum)
- Small Package: SC70

2 Applications

- WPC (Qi) 1.2-Compliant Wireless Power Transmitters for 15-W or 5-W Systems
- Proprietary Wireless Chargers and Transmitters
- Wirelessly-Powered Industrial and Medical Systems
- For more information, see www.ti.com/wirelesspower

3 Description

The bq500100 is a voltage output, current-shunt monitor for wireless charging to facilitate foreign object detection (FOD). This device can sense drops across shunts at common-mode voltages from 0 V to 20 V, independent of the supply voltage. The device features a fixed voltage gain of 50 V/V with a maximum gain error of 2% and a offset voltage of 150 μV (maximum).

This device operates from a single 2.7-V to 6-V power supply, drawing a maximum of 100 μA of supply current. The device is specified from -40°C to $+105^\circ\text{C}$ and is offered in the SC70 package.

Device Information⁽¹⁾

PART NUMBER	PACKAGE	BODY SIZE (NOM)
bq500100	SC70 (6)	2.00 mm x 1.25 mm

(1) For all available packages, see the orderable addendum at the end of the data sheet.

Typical Wireless Charging Application

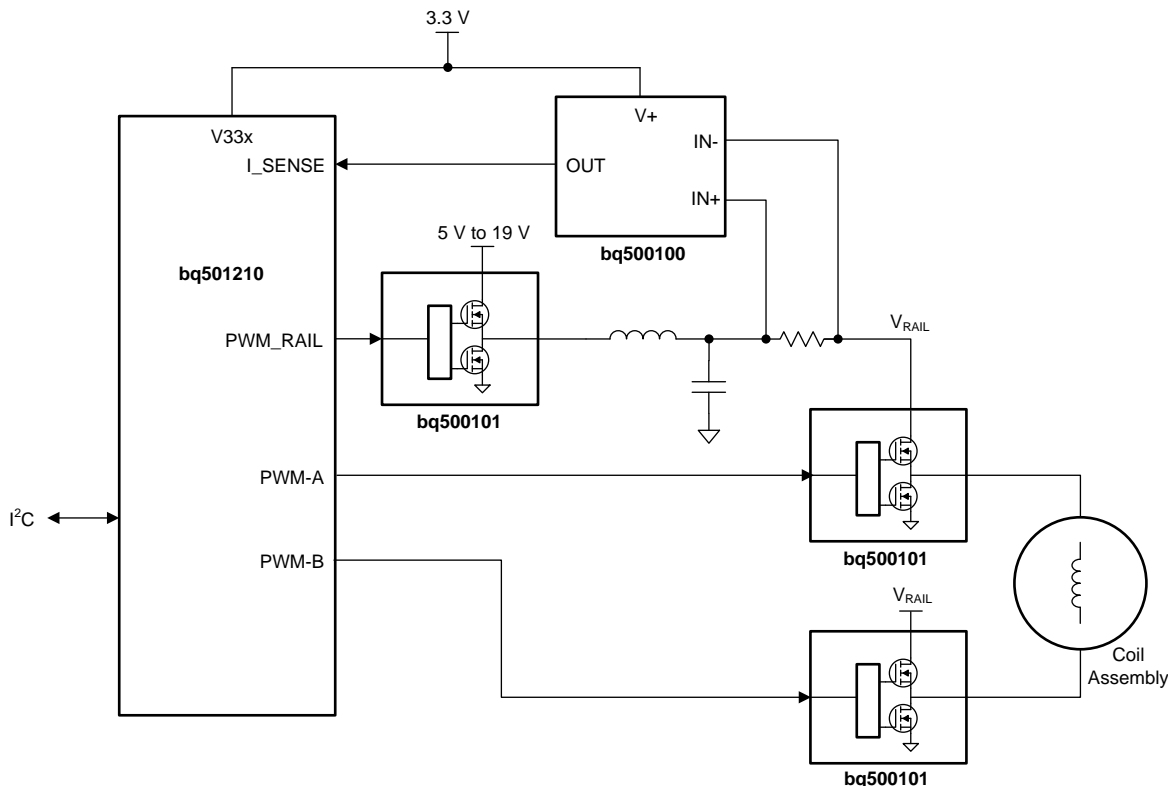

Table of Contents

1 Features	1	7.4 Device Functional Modes.....	8
2 Applications	1	8 Application and Implementation	9
3 Description	1	8.1 Application Information.....	9
4 Revision History	2	8.2 Typical Application	9
5 Pin Configuration and Functions	3	9 Power Supply Recommendations	11
6 Specifications	4	10 Layout	12
6.1 Absolute Maximum Ratings	4	10.1 Layout Guidelines	12
6.2 ESD Ratings.....	4	10.2 Layout Example	12
6.3 Recommended Operating Conditions.....	4	11 Device and Documentation Support	13
6.4 Thermal Information	4	11.1 Documentation Support	13
6.5 Electrical Characteristics.....	5	11.2 Community Resources.....	13
6.6 Typical Characteristics.....	6	11.3 Trademarks	13
7 Detailed Description	7	11.4 Electrostatic Discharge Caution.....	13
7.1 Overview	7	11.5 Glossary	13
7.2 Functional Block Diagram	7	12 Mechanical, Packaging, and Orderable	
7.3 Feature Description.....	7	Information	13

4 Revision History

DATE	REVISION	NOTES
January 2016	*	Initial release.

5 Pin Configuration and Functions

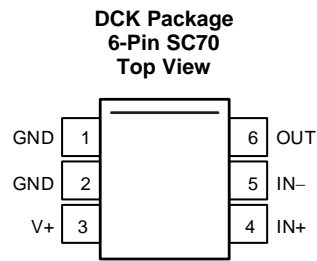

Pin Functions

PIN		I/O	DESCRIPTION
NAME	SC70		
GND	1, 2	Analog	Ground for the power-supply voltage rail
IN-	5	Analog input	Connect to load side of shunt resistor
IN+	4	Analog input	Connect to supply side of shunt resistor
OUT	6	Analog output	Output voltage
V+	3	Analog	Power supply, 2.7 V to 6 V

6 Specifications

6.1 Absolute Maximum Ratings

 over operating free-air temperature range (unless otherwise noted)⁽¹⁾

		MIN	MAX	UNIT
Supply voltage			7	V
Analog inputs, V_{IN+} , V_{IN-} ⁽²⁾	Differential (V_{IN+}) – (V_{IN-})	–26	26	V
	Common-mode ⁽³⁾	GND – 0.3	26	
Output ⁽³⁾		GND – 0.3	(V+) + 0.3	V
Input current Into all pins ⁽³⁾			5	mA
Temperature	Operating, T_A	–40	125	°C
	Junction, T_J		150	
	Storage, T_{stg}	–65	150	

- (1) Stresses beyond those listed under *Absolute Maximum Ratings* may cause permanent damage to the device. These are stress ratings only, which do not imply functional operation of the device at these or any other conditions beyond those indicated under *Recommended Operating Conditions*. Exposure to absolute-maximum-rated conditions for extended periods may affect device reliability.
- (2) V_{IN+} and V_{IN-} are the voltages at the IN+ and IN– pins, respectively.
- (3) Input voltage at any pin can exceed the voltage shown if the current at that pin is limited to 5 mA.

6.2 ESD Ratings

		VALUE	UNIT
$V_{(ESD)}$ Electrostatic discharge	Human-body model (HBM), per ANSI/ESDA/JEDEC JS-001 ⁽¹⁾	±2000	V
	Charged-device model (CDM), per JEDEC specification JESD22-C101 ⁽²⁾	±1000	
	Machine model (MM)	±200	

- (1) JEDEC document JEP155 states that 500-V HBM allows safe manufacturing with a standard ESD control process.
- (2) JEDEC document JEP157 states that 250-V CDM allows safe manufacturing with a standard ESD control process.

6.3 Recommended Operating Conditions

over operating free-air temperature range (unless otherwise noted)

		MIN	NOM	MAX	UNIT
V_{CM}	Common-mode input voltage		12		V
V_S	Operating supply voltage (applied to V+)		3.3		V
T_A	Operating free-air temperature	–40		105	°C

6.4 Thermal Information

THERMAL METRIC ⁽¹⁾		bq500100	UNIT
		DCK (SC70)	
		6 PINS	
$R_{\theta JA}$	Junction-to-ambient thermal resistance	227.3	°C/W
$R_{\theta JC(top)}$	Junction-to-case (top) thermal resistance	79.5	°C/W
$R_{\theta JB}$	Junction-to-board thermal resistance	72.1	°C/W
Ψ_{JT}	Junction-to-top characterization parameter	3.6	°C/W
Ψ_{JB}	Junction-to-board characterization parameter	70.4	°C/W
$R_{\theta JC(bot)}$	Junction-to-case (bottom) thermal resistance	N/A	°C/W

- (1) For more information about traditional and new thermal metrics, see the *Semiconductor and IC Package Thermal Metrics* application report, [SPRA953](#).

6.5 Electrical Characteristics

at $T_A = 25^\circ\text{C}$, $V_+ = 5\text{ V}$, $V_{\text{IN}+} = 12\text{ V}$, and $V_{\text{SENSE}} = V_{\text{IN}+} - V_{\text{IN}-}$ (unless otherwise noted)

PARAMETER		TEST CONDITIONS	MIN	TYP	MAX	UNIT
INPUT						
V_{CM}	Common-mode input range	$T_A = -40^\circ\text{C}$ to $+105^\circ\text{C}$	0		20	V
CMR	Common-mode rejection	$V_{\text{IN}+} = 0\text{ V}$ to 20 V , $T_A = -40^\circ\text{C}$ to $+105^\circ\text{C}$	100	120		dB
V_{OS}	Offset voltage, RTI ⁽¹⁾			± 5	± 150	μV
dV_{OS}/dT	Offset voltage, RTI vs temperature	$T_A = -40^\circ\text{C}$ to $+105^\circ\text{C}$		0.1	0.5	$\mu\text{V}/^\circ\text{C}$
PSR	Power-supply rejection	$V_+ = 2.7\text{ V}$ to 6 V , $V_{\text{IN}+} = 18\text{ V}$		± 0.1		$\mu\text{V}/\text{V}$
I_{B}	Input bias current			28		μA
I_{OS}	Input offset current			± 0.02		μA
OUTPUT						
G	Gain		49	50	51	V/V
	Maximum capacitive load	No sustained oscillation		1		nF
VOLTAGE OUTPUT⁽²⁾						
	Swing to V_+ power-supply rail	$R_{\text{L}} = 10\text{ k}\Omega$ to GND, $T_A = -40^\circ\text{C}$ to $+105^\circ\text{C}$		$(V_+) - 0.05$	$(V_+) - 0.2$	V
	Swing to GND	$R_{\text{L}} = 10\text{ k}\Omega$ to GND, $T_A = -40^\circ\text{C}$ to $+105^\circ\text{C}$		$(V_{\text{GND}}) + 0.005$	$(V_{\text{GND}}) + 0.05$	V
FREQUENCY RESPONSE						
GBW	Bandwidth	$C_{\text{LOAD}} = 10\text{ pF}$		80		kHz
SR	Slew rate			0.4		V/ μs
NOISE, RTI⁽¹⁾						
	Voltage noise density			25		nV/ $\sqrt{\text{Hz}}$
POWER SUPPLY						
V_{S}	Operating voltage range (applied to V_+)	$T_A = -40^\circ\text{C}$ to $+105^\circ\text{C}$	2.7		6	V
I_{Q}	Quiescent current	$V_{\text{SENSE}} = 0\text{ mV}$		65	100	μA
		$T_A = -40^\circ\text{C}$ to $+105^\circ\text{C}$			115	
TEMPERATURE RANGE						
	Specified range		-40		105	$^\circ\text{C}$
	Operating range		-40		125	$^\circ\text{C}$

(1) RTI = Referred-to-input.

(2) See typical characteristic curve, *Output Voltage Swing vs Output Current* (Figure 1).

6.6 Typical Characteristics

performance measured at $T_A = 25^\circ\text{C}$, $V_+ = 5\text{ V}$, and $V_{IN+} = 12\text{ V}$ (unless otherwise noted)

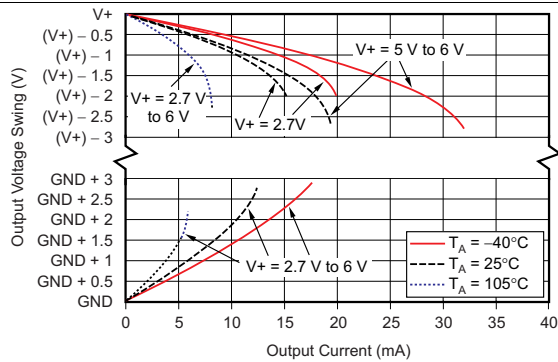

Figure 1. Output Voltage Swing vs Output Current

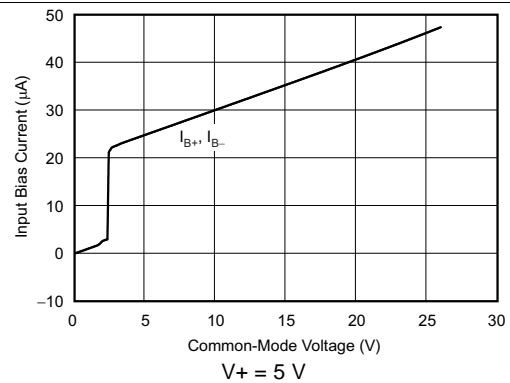

Figure 2. Input Bias Current vs Common-Mode Voltage

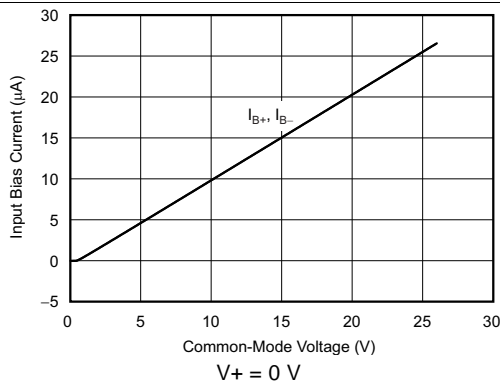

Figure 3. Input Bias Current vs Common-Mode Voltage (Shutdown)

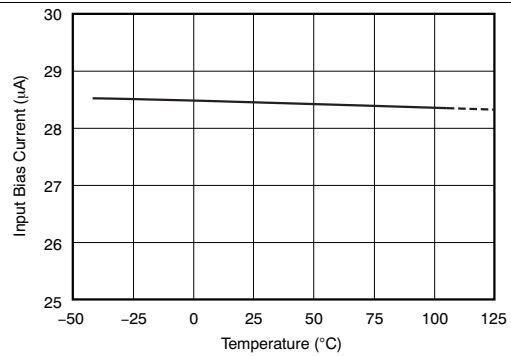

Figure 4. Input Bias Current vs Temperature

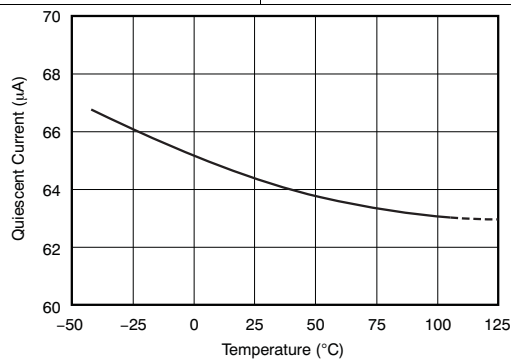

Figure 5. Quiescent Current vs Temperature

7 Detailed Description

7.1 Overview

The bq500100 is specially-designed to facilitate foreign object detection (FOD) in wireless charging applications by monitoring the coil supply current. The current-sensing amplifier is able to accurately measure voltages developed across a current-sensing resistor on common-mode voltages that far exceed the supply voltage powering the device. Current can be measured on input voltage rails as high as 20 V when the device is powered off a lower supply voltage.

Low drift characteristics enables high-precision measurements with maximum input offset voltages as low as 200 μV with a maximum temperature contribution of 0.5 $\mu\text{V}/^\circ\text{C}$ over the full temperature range of -40°C to $+105^\circ\text{C}$.

7.2 Functional Block Diagram

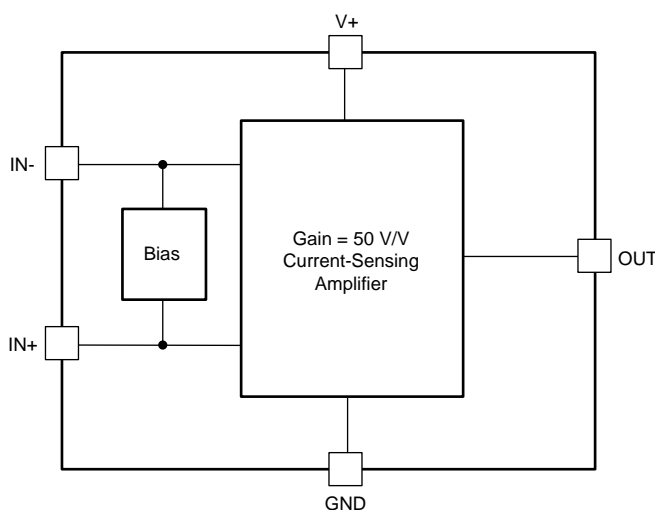

7.3 Feature Description

7.3.1 High Input Common-Mode Range

The bq500100 can support input common-mode voltages up to 20 V. Because of the internal topology, the common-mode range is not restricted by the supply voltage as long as the input supply stays within the operational range of 2.7 V to 6 V. The ability to operate with supply voltages lower than the input voltage common-mode signal makes the device well-suited for monitoring the current in wireless charging applications where the common-mode voltage varies to obtain a desired amount of power transfer.

When the dc common-mode voltage varies, the effect on the output voltage is very small as a result of the high common-mode rejection. The dc common-mode rejection for the bq500100 is expressed in decibels and is typically as high as 120 dB. In wireless charging applications, the current-sensed rail commonly varies in voltage to adjust for the amount of power transferred by the coil.

7.3.2 High Current-Sense Accuracy Over a Wide Dynamic Range

The offset voltage, gain error, and shunt resistor are the three primary contributors that determine the current measurement accuracy over a specified current range. The offset voltage dominates the error when operating at low current values and the gain error dominates when operating at high current values. The low offset voltage allows use of smaller shunt resistor values. Both the low offset and gain error allow the bq500100 to accurately measure current over a wide dynamic range and still maintain a high level of accuracy.

7.4 Device Functional Modes

7.4.1 Normal Operation

The bq500100 is in normal operation when the following conditions are met:

- $V+$ is between 2.7 V and 6.0 V
- The common-mode input voltage is less than 20 V
- The differential input signal times gain is less than the supply voltage minus the output voltage swing to $V+$
- The differential input signal times gain is greater than the swing to GND
- Current flows into the shunt resistor from $IN+$ to $IN-$ connection points (unidirectional)

When in the normal operating region, the device operates as expected and produces an output voltage that is the gained-up representation of the difference voltage from $IN+$ to $IN-$.

7.4.1.1 Device Power-Up

The topology of the bq500100 allows voltages to be present on the inputs before power is applied; therefore, there is no sequencing requirement in regards to the input voltages and the power supply rail for $V+$. There is a small delay of approximately 50 μ s from when power is applied to when the output voltage of the bq500100 settles to the correct voltage level.

7.4.1.2 Input Differential Overload

If the differential input voltage ($V_{IN+} - V_{IN-}$) multiplied by gain exceeds the voltage swing specification, the device drives the output as close as possible to the positive supply and does not provide accurate measurement of the differential input voltage. If this behavior occurs during normal circuit operation, then reduce the value of the shunt resistor to avoid this mode of operation. If a differential overload occurs in a fault event, then the output of the bq500100 returns to the expected value approximately 250 μ s after the fault condition is removed.

8 Application and Implementation

NOTE

Information in the following applications sections is not part of the TI component specification, and TI does not warrant its accuracy or completeness. TI's customers are responsible for determining suitability of components for their purposes. Customers should validate and test their design implementation to confirm system functionality.

8.1 Application Information

The bq500100 is tailored to monitor current in wireless charging applications. This section focuses on the current-sense requirements for wireless charging. A typical application schematic and design procedure are provided in this section as reference.

8.2 Typical Application

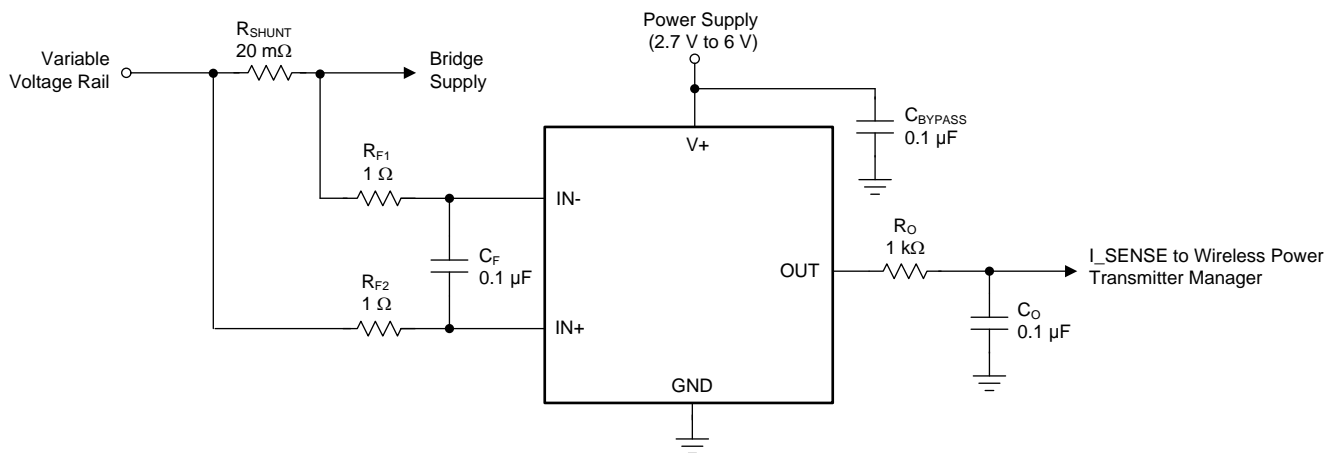

NOTE: $R_{F1} = R_{F2} = R_F$

Figure 6. Typical Application for Wireless Charging

8.2.1 Design Requirements

The design requirements for a typical wireless charging application is shown in Table 1. These requirements use the schematic shown in Figure 6.

Table 1. Design Parameters

PARAMETER	DESIGN REQUIREMENT
Supply voltage range for V+	3.3 V ± 3% provided by a dc-dc converter
Common-mode voltage range	9 V to 19 V provided by a dc-dc converter
Power loss in the shunt resistor	20 mW or less at 1 A
Current-monitoring accuracy (gain error + offset error)	Better than 2.3% at 1 A, $V_{CM} = 12$ V, $T_A = 25^\circ\text{C}$
I_SENSE peak-to-peak ripple	Less than 15 mV

8.2.2 Detailed Design Procedure

The first step in designing a solution is to make sure that the supply voltage and common-mode voltage are within the specified operational range of the device. For the supply and common-mode voltage requirements specified in Table 1, the bq500100 reliably operates and is an ideal fit for this application.

The next step is to select the desired value for the shunt resistor. In this application example, the maximum power dissipation in the shunt resistor is specified to be 20 mW or less with a 1-A current-sense signal. The maximum power dissipation requirement limits the maximum value of the shunt resistor to $20 \text{ mW} / (1 \text{ A})^2$, or 20 mΩ. To meet this application requirement and still maximize the current-sense accuracy, the maximum allowable resistance of 20 mΩ is selected.

Additional input filtering (see [Figure 6](#)) is required to mitigate the affects of differential noise and switching ripple because the device is sensing the voltage rail of the dc-dc supply. When adding series resistance to the input, keeping the resistance as small as possible is recommended because any added resistance adds to the gain error of the device. For the bq500100, the amount of additional gain error resulting from the filter resistance R_S can be calculated using [Equation 1](#):

$$\text{Gain Error (\%)} = 100 - \left(100 \times \frac{20,000}{(17 \times R_F) + 20,000} \right) \quad (1)$$

Applying [Equation 1](#) for the case where R_F is equal to 1 Ω results in an additional gain error of 0.085%. Applying this result to the total gain error is calculated to be approximately 2.085%.

The total offset voltage can be calculated by adding the effects of drift, change in supply voltage, and change in the common-mode input voltage to the specified offset voltage. In this example, no additional errors need to be added to the common-mode voltage and temperature because the conditions specified in [Table 1](#) match the V_{OS} conditions specified in the [Electrical Characteristics](#) table. The only additional error that needs to be added to the offset voltage is the effect of changes to the supply voltage. This document specifies a supply voltage of 5 V; however, this application calls for a supply voltage of 3.3 V. The change in offset voltage resulting from the difference in supply voltage can be calculated by using the PSR specification in this document; see the [Electrical Characteristics](#) table. The PSRR of the device is typically $\pm 0.1 \mu\text{V/V}$; therefore, the change in offset voltage can be calculated by taking the difference in supply voltage and multiplying by this value. In this case, the supply voltage difference is 1.7 V (5 V – 3.3 V), so the change in offset voltage is 0.17 μV. Therefore the total offset voltage error is 150.17 μV. Because the offset voltage error is a fixed value, the percentage influence on the accuracy is a function of the load current and can be calculated by applying [Equation 2](#).

$$\text{Total Offset Error (\%)} = \frac{\text{Total Offset Error (V)}}{I_{\text{SHUNT}}(\text{A}) \times R_{\text{SHUNT}}(\Omega)} \times 100\% \quad (2)$$

Applying [Equation 2](#) with an offset value of 150.15 μV, an R_{SHUNT} value of 20 mΩ, and a shunt current of 1 A results in a percentage error of 0.751%.

Now that the total gain error and offset error of the device are known, the accuracy of the current-shunt monitor can be calculated with [Equation 3](#):

$$\text{Total Error (\%)} = \sqrt{\text{Total Gain Error (\%)}^2 + \text{Total Offset Error (\%)}^2} \quad (3)$$

Applying [Equation 3](#) with a total gain error of 2.085% and a total offset error of 0.751% results in a total accuracy of 2.22% at 1 A, which is within the design target of 2.3%. Using a resistor tolerance of 0.5% to minimize errors introduced by R_{SHUNT} is recommended.

Additional output filtering consisting of R_O and C_O (see [Figure 6](#)) is required to further reduce the ripple at the bq500100 current-sense output. For best performance, keeping the ripple on the current monitor output below 15 mV is recommended. The values provided in [Figure 6](#) are sufficient for most use cases.

8.2.3 Application Curve

An example output response of the wireless charging application is shown in [Figure 7](#).

The coil driver current is shown in green and has both ac and dc components. The I_SENSE signal is shown in red and is filtered to generate a signal representative of the dc current for foreign object detection.

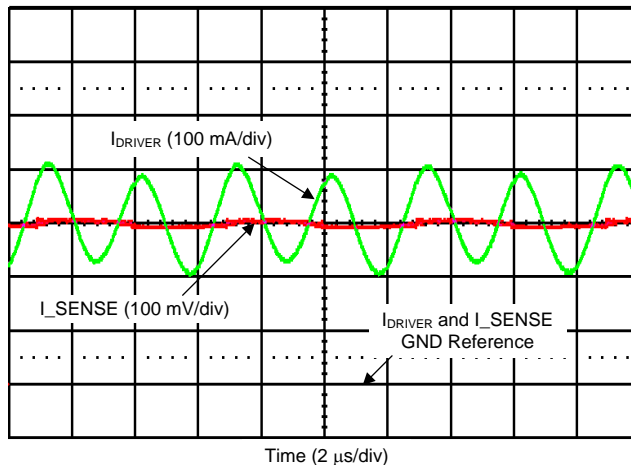

Figure 7. Current-Sense Output in a Wireless Charging Application

9 Power Supply Recommendations

The input circuitry of the bq500100 can accurately measure beyond its power-supply voltage, V₊. For example, the V₊ power supply can be 5 V, whereas the load power-supply voltage can be as high as 20 V. However, the output voltage range of the OUT pin is limited by the voltages on the power-supply pin. Also, the bq500100 can withstand the full input signal range up to the 20-V range in the input pins, regardless of whether the device has power applied or not.

10 Layout

10.1 Layout Guidelines

- Make connections to the shunt resistor with a Kelvin or 4-wire connection. This connection technique ensures that only the current-sensing resistor impedance is detected between the input pins. Poor routing of the current-sensing resistor commonly results in additional resistance present between the input pins. Given the very low ohmic value of the current resistor, any additional high-current carrying impedance can cause significant measurement errors.
- Place the power-supply bypass capacitor as closely as possible to the supply and ground pins. The recommended value of this bypass capacitor is 0.1 μF . Additional decoupling capacitance can be added to compensate for noisy or high-impedance power supplies.
- Place the input filter capacitor, C_F , as close as possible to the input pins of the device. Place the input filter resistors as close as possible to each other to minimize the enclosed loop area between the device and the shunt resistor.
- The output of the current-sense circuit must be located as close as possible to the wireless power transmitter manager device. If the distance to the wireless power transmitter is greater than 1 cm, the output filter capacitor (C_O) shown in [Figure 8](#) must be placed next to the I_SENSE pin of the wireless power transmitter manger. Placing the capacitor at the I_SENSE pin of the wireless power transmitter manger provides the best filtering of the current-sense signal.

10.2 Layout Example

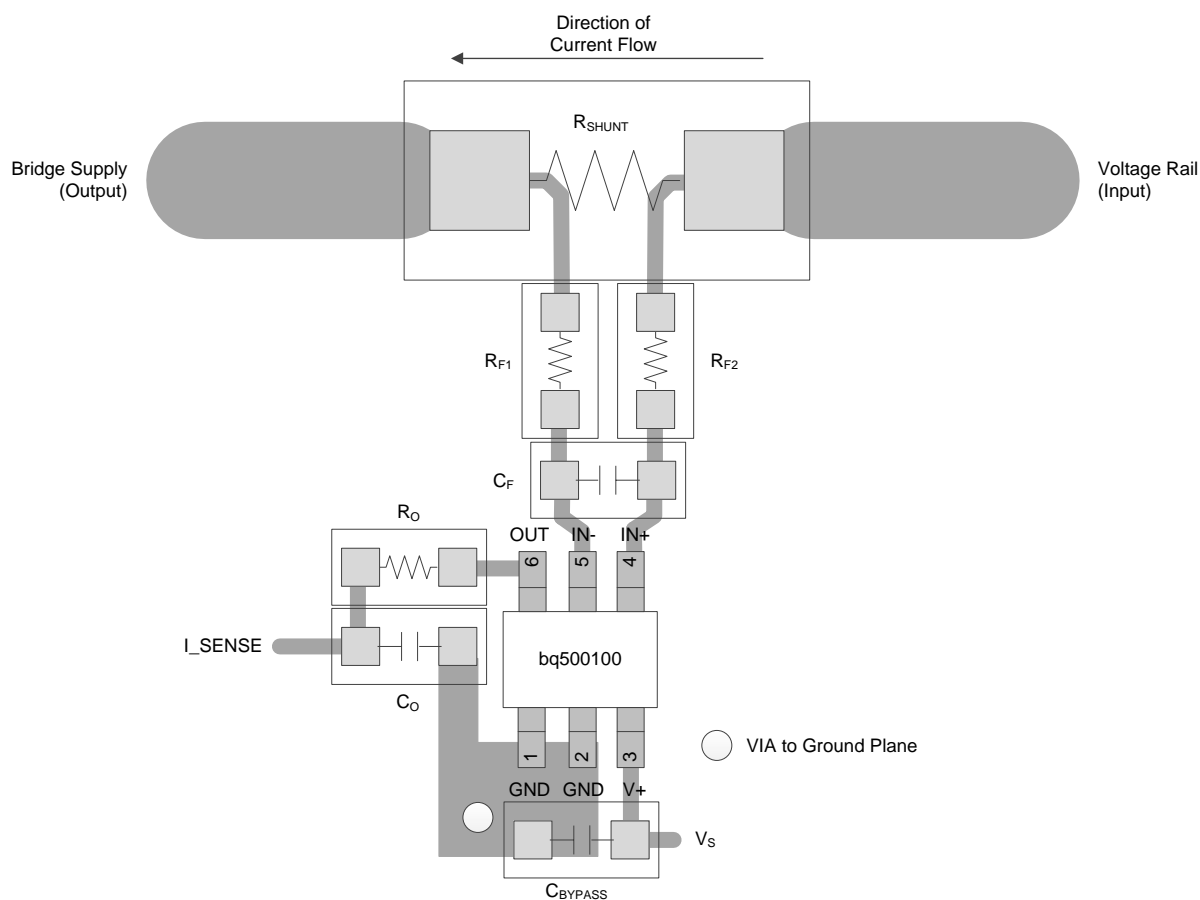

Figure 8. Recommended Layout

11 Device and Documentation Support

11.1 Documentation Support

11.1.1 Related Documentation

bq501210 Data Sheet, [SLUSCF5](#)

bq500101 Data Sheet, [SLPS585](#)

Transient Robustness for Current Shunt Monitor, [TIDU473](#)

11.2 Community Resources

The following links connect to TI community resources. Linked contents are provided "AS IS" by the respective contributors. They do not constitute TI specifications and do not necessarily reflect TI's views; see TI's [Terms of Use](#).

TI E2E™ Online Community *TI's Engineer-to-Engineer (E2E) Community*. Created to foster collaboration among engineers. At [e2e.ti.com](#), you can ask questions, share knowledge, explore ideas and help solve problems with fellow engineers.

Design Support *TI's Design Support* Quickly find helpful E2E forums along with design support tools and contact information for technical support.

11.3 Trademarks

E2E is a trademark of Texas Instruments.

All other trademarks are the property of their respective owners.

11.4 Electrostatic Discharge Caution



These devices have limited built-in ESD protection. The leads should be shorted together or the device placed in conductive foam during storage or handling to prevent electrostatic damage to the MOS gates.

11.5 Glossary

[SLYZ022](#) — *TI Glossary*.

This glossary lists and explains terms, acronyms, and definitions.

12 Mechanical, Packaging, and Orderable Information

The following pages include mechanical, packaging, and orderable information. This information is the most current data available for the designated devices. This data is subject to change without notice and revision of this document. For browser-based versions of this data sheet, refer to the left-hand navigation.

PACKAGING INFORMATION

Orderable Device	Status (1)	Package Type	Package Drawing	Pins	Package Qty	Eco Plan (2)	Lead/Ball Finish (6)	MSL Peak Temp (3)	Op Temp (°C)	Device Marking (4/5)	Samples
BQ500100DCKR	ACTIVE	SC70	DCK	6	3000	Green (RoHS & no Sb/Br)	CU NIPDAU	Level-2-260C-1 YEAR		12Y	Samples
BQ500100DCKT	ACTIVE	SC70	DCK	6	250	Green (RoHS & no Sb/Br)	CU NIPDAU	Level-2-260C-1 YEAR		12Y	Samples

(1) The marketing status values are defined as follows:

ACTIVE: Product device recommended for new designs.

LIFEBUY: TI has announced that the device will be discontinued, and a lifetime-buy period is in effect.

NRND: Not recommended for new designs. Device is in production to support existing customers, but TI does not recommend using this part in a new design.

PREVIEW: Device has been announced but is not in production. Samples may or may not be available.

OBsolete: TI has discontinued the production of the device.

(2) Eco Plan - The planned eco-friendly classification: Pb-Free (RoHS), Pb-Free (RoHS Exempt), or Green (RoHS & no Sb/Br) - please check <http://www.ti.com/productcontent> for the latest availability information and additional product content details.

TBD: The Pb-Free/Green conversion plan has not been defined.

Pb-Free (RoHS): TI's terms "Lead-Free" or "Pb-Free" mean semiconductor products that are compatible with the current RoHS requirements for all 6 substances, including the requirement that lead not exceed 0.1% by weight in homogeneous materials. Where designed to be soldered at high temperatures, TI Pb-Free products are suitable for use in specified lead-free processes.

Pb-Free (RoHS Exempt): This component has a RoHS exemption for either 1) lead-based flip-chip solder bumps used between the die and package, or 2) lead-based die adhesive used between the die and leadframe. The component is otherwise considered Pb-Free (RoHS compatible) as defined above.

Green (RoHS & no Sb/Br): TI defines "Green" to mean Pb-Free (RoHS compatible), and free of Bromine (Br) and Antimony (Sb) based flame retardants (Br or Sb do not exceed 0.1% by weight in homogeneous material)

(3) MSL, Peak Temp. - The Moisture Sensitivity Level rating according to the JEDEC industry standard classifications, and peak solder temperature.

(4) There may be additional marking, which relates to the logo, the lot trace code information, or the environmental category on the device.

(5) Multiple Device Markings will be inside parentheses. Only one Device Marking contained in parentheses and separated by a "~" will appear on a device. If a line is indented then it is a continuation of the previous line and the two combined represent the entire Device Marking for that device.

(6) Lead/Ball Finish - Orderable Devices may have multiple material finish options. Finish options are separated by a vertical ruled line. Lead/Ball Finish values may wrap to two lines if the finish value exceeds the maximum column width.

Important Information and Disclaimer: The information provided on this page represents TI's knowledge and belief as of the date that it is provided. TI bases its knowledge and belief on information provided by third parties, and makes no representation or warranty as to the accuracy of such information. Efforts are underway to better integrate information from third parties. TI has taken and continues to take reasonable steps to provide representative and accurate information but may not have conducted destructive testing or chemical analysis on incoming materials and chemicals. TI and TI suppliers consider certain information to be proprietary, and thus CAS numbers and other limited information may not be available for release.

In no event shall TI's liability arising out of such information exceed the total purchase price of the TI part(s) at issue in this document sold by TI to Customer on an annual basis.

DCK (R-PDSO-G6)

PLASTIC SMALL-OUTLINE PACKAGE

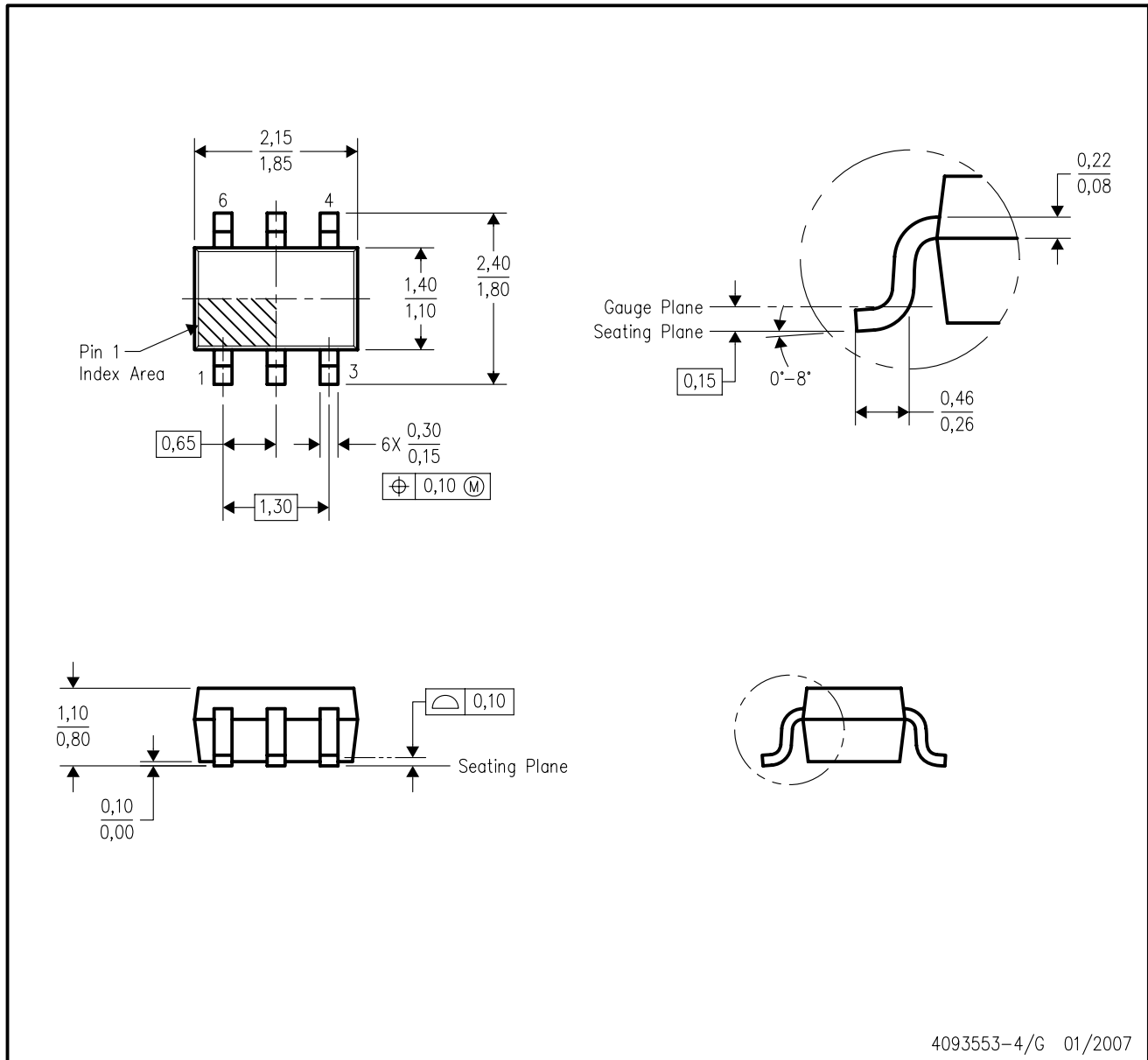

- NOTES:
- A. All linear dimensions are in millimeters.
 - B. This drawing is subject to change without notice.
 - C. Body dimensions do not include mold flash or protrusion. Mold flash and protrusion shall not exceed 0.15 per side.
 - D. Falls within JEDEC MO-203 variation AB.

DCK (R-PDSO-G6)

PLASTIC SMALL OUTLINE

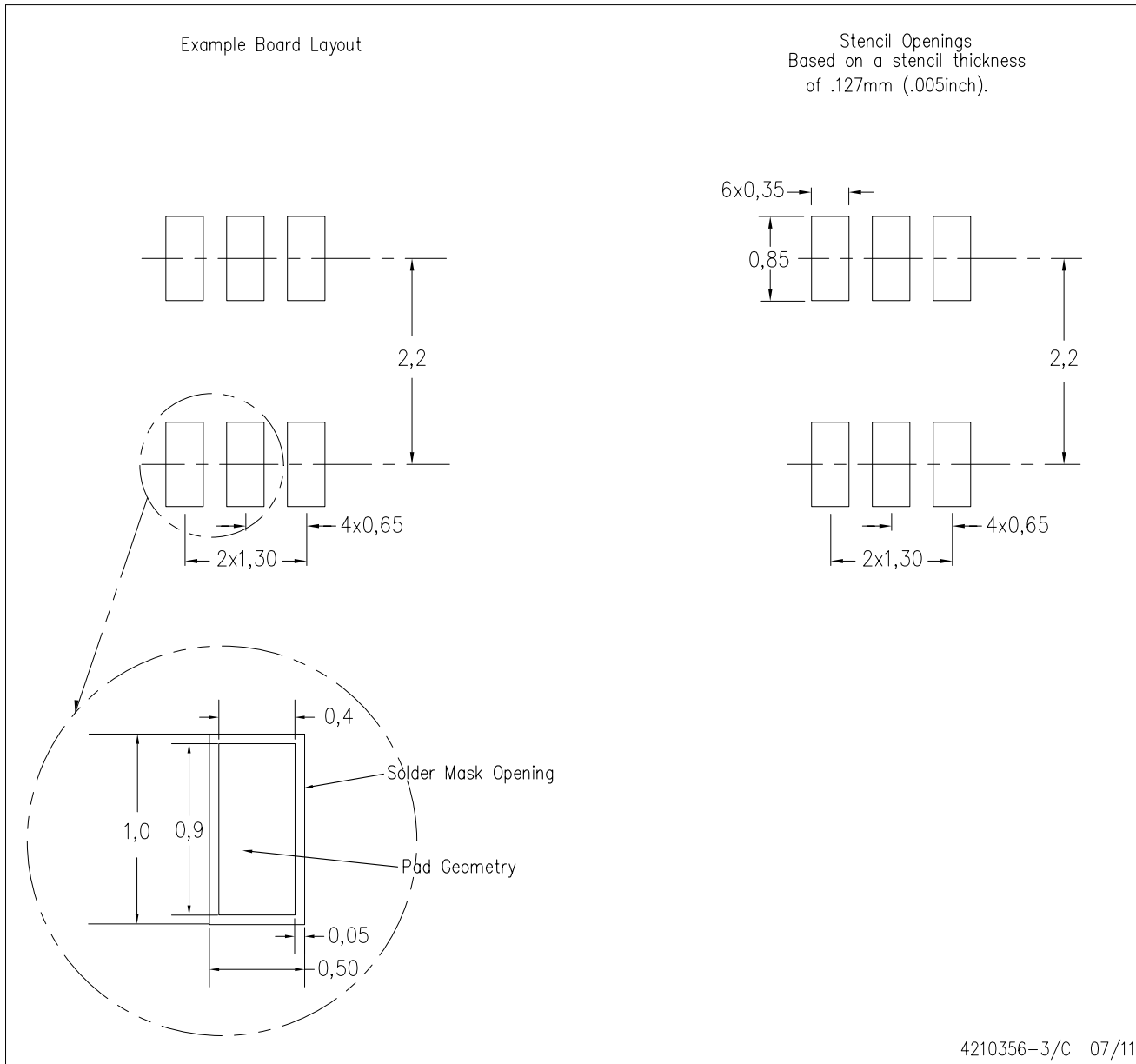

- NOTES:
- All linear dimensions are in millimeters.
 - This drawing is subject to change without notice.
 - Customers should place a note on the circuit board fabrication drawing not to alter the center solder mask defined pad.
 - Publication IPC-7351 is recommended for alternate designs.
 - Laser cutting apertures with trapezoidal walls and also rounding corners will offer better paste release. Customers should contact their board assembly site for stencil design recommendations. Example stencil design based on a 50% volumetric metal load solder paste. Refer to IPC-7525 for other stencil recommendations.

IMPORTANT NOTICE AND DISCLAIMER

TI PROVIDES TECHNICAL AND RELIABILITY DATA (INCLUDING DATASHEETS), DESIGN RESOURCES (INCLUDING REFERENCE DESIGNS), APPLICATION OR OTHER DESIGN ADVICE, WEB TOOLS, SAFETY INFORMATION, AND OTHER RESOURCES "AS IS" AND WITH ALL FAULTS, AND DISCLAIMS ALL WARRANTIES, EXPRESS AND IMPLIED, INCLUDING WITHOUT LIMITATION ANY IMPLIED WARRANTIES OF MERCHANTABILITY, FITNESS FOR A PARTICULAR PURPOSE OR NON-INFRINGEMENT OF THIRD PARTY INTELLECTUAL PROPERTY RIGHTS.

These resources are intended for skilled developers designing with TI products. You are solely responsible for (1) selecting the appropriate TI products for your application, (2) designing, validating and testing your application, and (3) ensuring your application meets applicable standards, and any other safety, security, or other requirements. These resources are subject to change without notice. TI grants you permission to use these resources only for development of an application that uses the TI products described in the resource. Other reproduction and display of these resources is prohibited. No license is granted to any other TI intellectual property right or to any third party intellectual property right. TI disclaims responsibility for, and you will fully indemnify TI and its representatives against, any claims, damages, costs, losses, and liabilities arising out of your use of these resources.

TI's products are provided subject to TI's Terms of Sale (www.ti.com/legal/termsofsale.html) or other applicable terms available either on ti.com or provided in conjunction with such TI products. TI's provision of these resources does not expand or otherwise alter TI's applicable warranties or warranty disclaimers for TI products.

Mailing Address: Texas Instruments, Post Office Box 655303, Dallas, Texas 75265
Copyright © 2019, Texas Instruments Incorporated

Looking for pricing, stock, or lifecycle information?

Click below to explore more details on WIN SOURCE:

 [View BQ500100DCKT](#) on WIN SOURCE

 [Texas Instruments](#) Information

Optimize Your Supply Chain with WIN SOURCE Solutions

-  Global Sourcing Solution
-  Obsolete Management
-  Cost Control Management
-  Shortage Management
-  Alternative Solution
-  Excess Inventory Management