



# System-Side Impedance Track™ Fuel Gauge with Dynamic Voltage Correlation

Check for Samples: [bq27620-G1](#)

## 1 INTRODUCTION

### 1.1 FEATURES

- **Battery Fuel Gauge for 1-Series Li-Ion applications based on Patented Impedance Track™ Technology with Dynamic Voltage Correlation (IT-DVC)**
- **Resides on System Main Board**
- **No Sense Resistor Required**
- **Powered directly from battery with integrated LDO**
- **Supports embedded or removable Battery Packs**
- **System Side Fuel-Gauge Provides:**
  - **Accurate Battery Fuel Gauging; models the Battery Discharge Curve for Accurate Time-to-Empty Predictions**
  - **Automatically Adjusts for Battery Aging, Battery Self-Discharge, and Temperature/Rate Inefficiencies**
  - **Internal Temperature Sensor for Battery Temperature Reporting**
  - **Battery Low Interrupt Warning**
  - **Battery Insertion Indicator**
  - **Configurable Level of State of Charge (SOC) Interrupts**
  - **State of Health Indicator**
  - **32 Bytes of Non-Volatile Scratch-Pad FLASH**
- **400-kHz I<sup>2</sup>C™ Interface for Connection to System Microcontroller Port**
- **In a 15-Pin NanoFree™ (CSP) Packaging**

### 1.2 APPLICATIONS

- **Smartphones**
- **Digital Still and Video Cameras**
- **Handheld Terminals**
- **MP3 or Multimedia Players**

### 1.3 DESCRIPTION

The Texas Instruments bq27620-G1 system-side is an easy configure microcontroller peripheral that provides fuel gauging for single-cell Li-Ion battery packs. The device requires minimal user configuration and system microcontroller firmware development.

The bq27620-G1 uses the patented Impedance Track™ algorithm with Dynamic Voltage Correlation for fuel gauging. This patented process eliminates the need for a **sense resistor** when calculating remaining battery capacity (mAh), state-of-charge (%), run-time to empty (min), battery voltage (mV), temperature (°C) and state of health (%).

Battery fuel gauging with the bq27620-G1 requires connections only to PACK+ (P+), PACK- (P-), and Thermistor (T) connections to a removable battery pack or embedded battery circuit. The CSP option is a 15-ball package in the nominal dimensions of 2610 × 1956 μm with 0,5 mm lead pitch. It is ideal for space constrained applications.

### TYPICAL APPLICATION

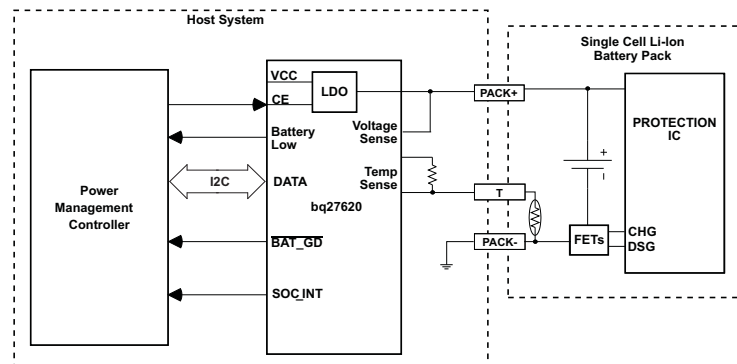

Please be aware that an important notice concerning availability, standard warranty, and use in critical applications of Texas Instruments semiconductor products and disclaimers thereto appears at the end of this data sheet.

Impedance Track, NanoFree are trademarks of Texas Instruments.  
I<sup>2</sup>C is a trademark of NXP B.V. Corp Netherlands.



These devices have limited built-in ESD protection. The leads should be shorted together or the device placed in conductive foam during storage or handling to prevent electrostatic damage to the MOS gates.

<b>1</b>	<b>INTRODUCTION</b>	<b>1</b>	4.2	DATA FLASH INTERFACE	19
1.1	FEATURES	1	4.3	MANUFACTURER INFORMATION BLOCK	20
1.2	APPLICATIONS	1	4.4	ACCESS MODES	21
1.3	DESCRIPTION	1	4.5	SEALING/UNSEALING DATA FLASH	21
<b>2</b>	<b>DEVICE INFORMATION</b>	<b>3</b>	4.6	DATA FLASH SUMMARY	22
2.1	AVAILABLE OPTIONS	3	<b>5</b>	<b>FUNCTIONAL DESCRIPTION</b>	<b>26</b>
2.2	THERMAL INFORMATION	3	5.1	FUEL GAUGING	26
2.3	PIN ASSIGNMENT AND PACKAGE DIMENSIONS	4	5.2	IMPEDANCE TRACK™ VARIABLES	27
<b>3</b>	<b>ELECTRICAL SPECIFICATIONS</b>	<b>5</b>	5.3	DETAILED PIN DESCRIPTION	29
3.1	ABSOLUTE MAXIMUM RATINGS	5	5.4	TEMPERATURE MEASUREMENT	34
3.2	RECOMMENDED OPERATING CONDITIONS	5	5.5	OVERTEMPERATURE INDICATION	34
3.3	SUPPLY CURRENT	5	5.6	CHARGING AND CHARGE-TERMINATION INDICATION	34
3.4	DIGITAL INPUT AND OUTPUT DC CHARACTERISTICS	6	5.7	POWER MODES	35
3.5	POWER-ON RESET	6	<b>6</b>	<b>APPLICATION-SPECIFIC INFORMATION</b>	<b>36</b>
3.6	2.5V LDO REGULATOR	6	6.1	BATTERY PROFILE STORAGE AND SELECTION	36
3.7	INTERNAL CLOCK OSCILLATORS	6	<b>7</b>	<b>COMMUNICATIONS</b>	<b>37</b>
3.8	ADC (TEMPERATURE AND CELL MEASUREMENT) CHARACTERISTICS	7	7.1	I <sup>2</sup> C INTERFACE	37
3.9	DATA FLASH MEMORY CHARACTERISTICS	8	7.2	I <sup>2</sup> C Time Out	37
3.10	I <sup>2</sup> C-COMPATIBLE INTERFACE COMMUNICATION TIMING CHARACTERISTICS	8	7.3	I <sup>2</sup> C Command Waiting Time	38
<b>4</b>	<b>GENERAL DESCRIPTION</b>	<b>9</b>	7.4	I <sup>2</sup> C Clock Stretching	38
4.1	DATA COMMANDS	10	<b>8</b>	<b>REFERENCE SCHEMATICS</b>	<b>39</b>
			8.1	SCHEMATIC	39

## 2 DEVICE INFORMATION

### 2.1 AVAILABLE OPTIONS

PART NUMBER	FIRMWARE VERSION <sup>(1)</sup>	PACKAGE <sup>(1)</sup>	T <sub>A</sub>	COMMUNICATION FORMAT	TAPE and REEL QUANTITY
bq27620YZFR-G1	1.06 (0x106)	CSP-15	-40°C to 85°C	I <sup>2</sup> C	3000
bq27620YZFT-G1					250

(1) For the most current package and ordering information, see the Package Option Addendum at the end of this document, or see the TI website at [www.ti.com](http://www.ti.com).

### 2.2 THERMAL INFORMATION

THERMAL METRIC <sup>(1)</sup>		bq27620-G1	UNITS
		YZF(15 PINS)	
$\theta_{JA}$	Junction-to-ambient thermal resistance	70	°C/W
$\theta_{JTop}$	Junction-to-case (top) thermal resistance	17	
$\theta_{JB}$	Junction-to-board thermal resistance	20	
$\psi_{JT}$	Junction-to-top characterization parameter	1	
$\psi_{JB}$	Junction-to-board characterization parameter	18	
$\theta_{JCbott}$	Junction-to-case (bottom) thermal resistance	n/a	

(1) For more information about traditional and new thermal metrics, see the IC Package Thermal Metrics application report, [SPRA953](http://SPRA953)

### 2.3 PIN ASSIGNMENT AND PACKAGE DIMENSIONS

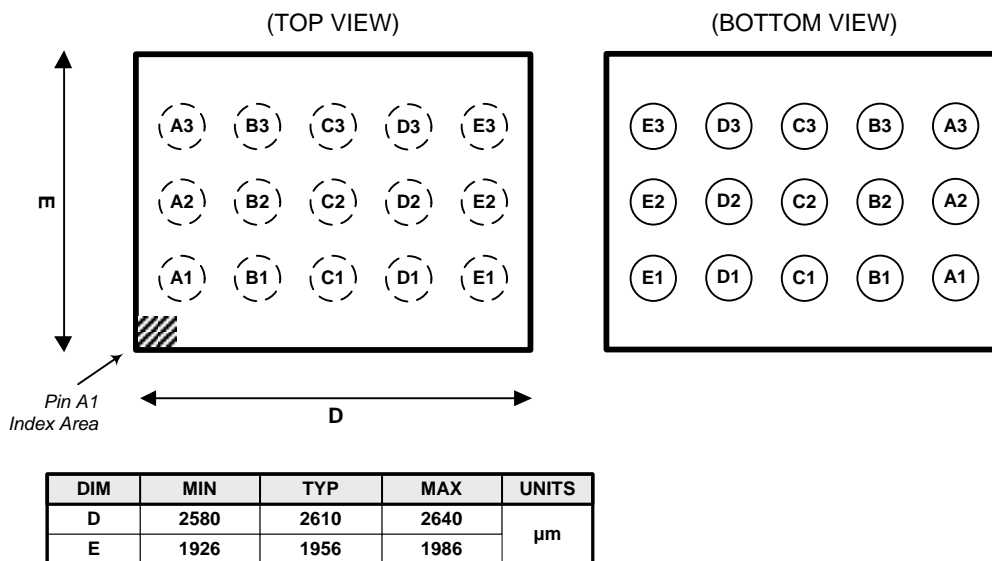

Table 2-1. PIN FUNCTIONS

PIN		TYPE <sup>(1)</sup>	DESCRIPTION
NAME	NO.		
V <sub>SS</sub>	A1, B1, C1, C2	P	Device ground
V <sub>CC</sub>	D1	P	Regulator output and bq27620-G1 processor power. Decouple with 1μF ceramic capacitor to V <sub>SS</sub> .
REGIN	E1	P	Regulator input. Decouple with 0.1μF ceramic capacitor to V <sub>SS</sub> .
SOC_INT	A2	O	SOC state interrupts output. Generates a pulse under the conditions specified by Table 5-7. Open drain output. (RA3)
BAT_GD	B2	O	Battery-good indicator. Active-low by default, though polarity can be configured through the [BATG_POL] bit of <b>Operation Configuration</b> . Push-pull output. (RC1)
CE	D2	I	Chip Enable. Internal LDO is disconnected from REGIN when driven low.
BAT	E2	I	Cell-voltage measurement input. ADC input. Recommend 4.8V maximum for conversion accuracy. (RC3)
SCL	A3	I	Slave I <sup>2</sup> C serial communications clock input line for communication with system (Master). Use with 10kΩ pull-up resistor (typical). (RA2)
SDA	B3	I/O	Slave I <sup>2</sup> C serial communications data line for communication with system (Master). Open-drain I/O. Use with 10kΩ pull-up resistor (typical). (RA1)
BAT_LOW	C3	O	Battery Low output indicator. Active high by default, though polarity can be configured through the [BATL_POL] bit of <b>Operation Configuration</b> . Push-pull output. (RC0)
TS	D3	IA	Pack thermistor voltage sense (use 103AT-type thermistor). ADC input. (RC2)
BI/TOUT	E3	I/O	Battery-insertion detection input. Power pin for pack thermistor network. Thermistor-multiplexer control pin. Use with pull-up resistor >1MΩ (1.8 MΩ typical). (RA0)

(1) I/O = Digital input/output, IA = Analog input, P = Power connection

### 3 ELECTRICAL SPECIFICATIONS

#### 3.1 ABSOLUTE MAXIMUM RATINGS

over operating free-air temperature range (unless otherwise noted)<sup>(1)</sup>

PARAMETER		VALUE	UNIT
V <sub>REGIN</sub>	Regulator input range	-0.3 to 5.5	V
		-0.3 to 6.0 <sup>(2)</sup>	V
V <sub>CC</sub>	Supply voltage range	-0.3 to 2.75	V
V <sub>IOD</sub>	Open-drain I/O pins (SDA, SCL, SOC_INT)	-0.3 to 5.5	V
V <sub>BAT</sub>	BAT input pin	-0.3 to 5.5	V
		-0.3 to 6.0 <sup>(2)</sup>	V
V <sub>I</sub>	Input voltage range to all other pins ( BI/TOUT , TS , BAT_GD )	-0.3 to V <sub>CC</sub> + 0.3	V
ESD	Human-body model (HBM), BAT pin	1.5	kV
	Human-body model (HBM), all other pins	2	
T <sub>A</sub>	Operating free-air temperature range	-40 to 85	°C
T <sub>F</sub>	Functional temperature range	-40 to 100	°C
T <sub>stg</sub>	Storage temperature range	-65 to 150	°C

- (1) Stresses beyond those listed under "absolute maximum ratings" may cause permanent damage to the device. These are stress ratings only, and functional operation of the device at these or any other conditions beyond those indicated under "recommended operating conditions" is not implied. Exposure to absolute-maximum-rated conditions for extended periods may affect device reliability.
- (2) Condition not to exceed 100 hours at 25 °C lifetime.

#### 3.2 RECOMMENDED OPERATING CONDITIONS

T<sub>A</sub> = -40°C to 85°C, V<sub>REGIN</sub> = V<sub>BAT</sub> = 3.6V (unless otherwise noted)

PARAMETER	TEST CONDITIONS	MIN	TYP	MAX	UNIT
V <sub>REGIN</sub>	Supply voltage				V
	No operating restrictions	2.8		4.5	
	No FLASH writes	2.45		2.8	
C <sub>REGIN</sub>	External input capacitor for internal LDO between REGIN and V <sub>SS</sub>		0.1		μF
C <sub>LDO25</sub>	External output capacitor for internal LDO between V <sub>CC</sub> and V <sub>SS</sub>	0.47	1		μF
t <sub>PUCD</sub>	Power-up communication delay		250		ms

#### 3.3 SUPPLY CURRENT

T<sub>A</sub> = 25°C and V<sub>REGIN</sub> = V<sub>BAT</sub> = 3.6V (unless otherwise noted)

PARAMETER	TEST CONDITIONS	MIN	TYP	MAX	UNIT
I <sub>CC</sub>	Normal operating-mode current <sup>(1)</sup> Fuel gauge in NORMAL mode. I <sub>LOAD</sub> > <b>Sleep Current</b>		118		μA
I <sub>SLP</sub>	Low-power storage-mode current <sup>(1)</sup> Fuel gauge in SLEEP mode. I <sub>LOAD</sub> < <b>Sleep Current</b>		23		μA
I <sub>HIB</sub>	Hibernate operating-mode current <sup>(1)</sup> Fuel gauge in HIBERNATE mode. I <sub>LOAD</sub> < <b>Hibernate Current</b>		8		μA

- (1) Specified by design. Not production tested.

### 3.4 DIGITAL INPUT AND OUTPUT DC CHARACTERISTICS

$T_A = -40^\circ\text{C}$  to  $85^\circ\text{C}$ , typical values at  $T_A = 25^\circ\text{C}$  and  $V_{\text{REGIN}} = 3.6\text{ V}$  (unless otherwise noted)

PARAMETER		TEST CONDITIONS	MIN	TYP	MAX	UNIT
$V_{\text{OL}}$	Output voltage, low (SCL, SDA, SOC_INT, BAT_LOW, BAT_GD)	$I_{\text{OL}} = 3\text{ mA}$			0.4	V
$V_{\text{OH(PP)}}$	Output voltage, high (BAT_LOW, BAT_GD)	$I_{\text{OH}} = -1\text{ mA}$	$V_{\text{CC}} - 0.5$			V
$V_{\text{OH(OD)}}$	Output voltage, high (SDA, SCL, SOC_INT)	External pullup resistor connected to $V_{\text{CC}}$	$V_{\text{CC}} - 0.5$			
$V_{\text{IL}}$	Input voltage, low (SDA, SCL pins)		-0.3		0.6	V
	Input voltage, low (BI/TOUT pin)	BAT INSERT CHECK MODE active	-0.3		0.6	
$V_{\text{IH}}$	Input voltage, high (SDA, SCL pins)		1.2			V
	Input voltage, high (BI/TOUT pin)	BAT INSERT CHECK MODE active	1.2		$V_{\text{CC}} + 0.3$	
$V_{\text{IL(CE)}}$	Input voltage, low (CE pin)				0.8	V
$V_{\text{IH(CE)}}$	Input voltage, high (CE pin)	$V_{\text{REGIN}} = 2.8$ to $4.5\text{V}$	$V_{\text{REGIN}} - 0.5$			
$I_{\text{Ikg}}$	Input leakage current (I/O pins) (1)				0.3	$\mu\text{A}$

(1) Specified by design. Not production tested.

### 3.5 POWER-ON RESET

$T_A = -40^\circ\text{C}$  to  $85^\circ\text{C}$ , typical values at  $T_A = 25^\circ\text{C}$  and  $V_{\text{REGIN}} = 3.6\text{ V}$  (unless otherwise noted)

PARAMETER	TEST CONDITIONS	MIN	TYP	MAX	UNIT
$V_{\text{IT+}}$	Positive-going battery voltage input at $V_{\text{CC}}$	2.05	2.15	2.20	V
$V_{\text{HYS}}$	Power-on reset hysteresis	45	115	185	mV

### 3.6 2.5V LDO REGULATOR

$T_A = -40^\circ\text{C}$  to  $85^\circ\text{C}$ ,  $C_{\text{LDO25}} = 1\mu\text{F}$ ,  $V_{\text{REGIN}} = 3.6\text{V}$  (unless otherwise noted)

PARAMETER	TEST CONDITION	MIN	NOM	MAX	UNIT	
$V_{\text{REG25}}$	Regulator output voltage	$2.8\text{V} \leq V_{\text{REGIN}} \leq 4.5\text{V}$ , $I_{\text{OUT}} \leq 16\text{mA}$	2.3	2.5	2.6	V
		$2.45\text{V} \leq V_{\text{REGIN}} < 2.8\text{V}$ (low battery), $I_{\text{OUT}} \leq 3\text{mA}$	2.3			V

### 3.7 INTERNAL CLOCK OSCILLATORS

$T_A = -40^\circ\text{C}$  to  $85^\circ\text{C}$ ,  $2.4\text{ V} < V_{\text{CC}} < 2.6\text{ V}$ ; typical values at  $T_A = 25^\circ\text{C}$  and  $V_{\text{CC}} = 2.5\text{ V}$  (unless otherwise noted)

PARAMETER	TEST CONDITIONS	MIN	TYP	MAX	UNIT
$f_{\text{OSC}}$	High Frequency Oscillator		2.097		MHz
$f_{\text{LOSC}}$	Low Frequency Oscillator		32.768		kHz

### 3.8 ADC (TEMPERATURE AND CELL MEASUREMENT) CHARACTERISTICS

$T_A = -40^{\circ}\text{C}$  to  $85^{\circ}\text{C}$ ,  $2.4\text{ V} < V_{CC} < 2.6\text{ V}$ ; typical values at  $T_A = 25^{\circ}\text{C}$  and  $V_{CC} = 2.5\text{ V}$  (unless otherwise noted)

PARAMETER	TEST CONDITIONS	MIN	TYP	MAX	UNIT
$V_{A1}$	Input voltage range (TS)	$V_{SS} - 0.125$		2	V
$V_{A2}$	Input voltage range (BAT)	$V_{SS} - 0.125$		5	V
$V_{IN(ADC)}$	Input voltage range	0.05		1	V
$G_{TEMP}$	Internal temperature sensor voltage gain		-2		mV/°C
$t_{ADC\_CONV}$	Conversion time			125	ms
	Resolution	14		15	bits
$V_{OS(ADC)}$	Input offset		1		mV
$Z_{ADC1}$	Effective input resistance (TS) <sup>(1)</sup>	8			MΩ
$Z_{ADC2}$	Effective input resistance (BAT) <sup>(1)</sup>	bq27620-G1 not measuring cell voltage		8	MΩ
		bq27620-G1 measuring cell voltage		100	kΩ
$I_{lkg(ADC)}$	Input leakage current <sup>(1)</sup>			0.3	μA

(1) Specified by design. Not tested in production.

### 3.9 DATA FLASH MEMORY CHARACTERISTICS

$T_A = -40^{\circ}\text{C}$  to  $85^{\circ}\text{C}$ ,  $2.4\text{ V} < V_{CC} < 2.6\text{ V}$ ; typical values at  $T_A = 25^{\circ}\text{C}$  and  $V_{CC} = 2.5\text{ V}$  (unless otherwise noted)

PARAMETER	TEST CONDITIONS	MIN	TYP	MAX	UNIT
$t_{DR}$	Data retention <sup>(1)</sup>	10			Years
	Flash-programming write cycles <sup>(1)</sup>	20,000			Cycles
$t_{WORDPROG}$	Word programming time <sup>(1)</sup>			2	ms
$I_{CCPROG}$	Flash-write supply current <sup>(1)</sup>		5	10	mA
$t_{DFERASE}$	Data flash master erase time <sup>(1)</sup>	200			ms
$t_{IFERASE}$	Instruction flash master erase time <sup>(1)</sup>	200			ms
$t_{PGERASE}$	Flash page erase time <sup>(1)</sup>	20			ms

(1) Specified by design. Not production tested

### 3.10 I<sup>2</sup>C-COMPATIBLE INTERFACE COMMUNICATION TIMING CHARACTERISTICS

$T_A = -40^{\circ}\text{C}$  to  $85^{\circ}\text{C}$ ,  $2.4\text{ V} < V_{CC} < 2.6\text{ V}$ ; typical values at  $T_A = 25^{\circ}\text{C}$  and  $V_{CC} = 2.5\text{ V}$  (unless otherwise noted)

PARAMETER	TEST CONDITIONS	MIN	TYP	MAX	UNIT
$t_r$	SCL/SDA rise time			300	ns
$t_f$	SCL/SDA fall time			300	ns
$t_{w(H)}$	SCL pulse duration (high)	600			ns
$t_{w(L)}$	SCL pulse duration (low)	1.3			$\mu\text{s}$
$t_{su(STA)}$	Setup for repeated start	600			ns
$t_{d(STA)}$	Start to first falling edge of SCL	600			ns
$t_{su(DAT)}$	Data setup time	100			ns
$t_h(DAT)$	Data hold time	0			ns
$t_{su(STOP)}$	Setup time for stop	600			ns
$t_{(BUF)}$	Bus free time between stop and start	66			$\mu\text{s}$
$f_{SCL}$	Clock frequency <sup>(1)</sup>			400	kHz

(1) If the clock frequency ( $f_{SCL}$ ) is  $> 100\text{ kHz}$ , use 1-byte write commands for proper operation. All other transactions types are supported at  $400\text{ kHz}$ . (Refer to [Section 7.1](#) and [Section 7.3](#))

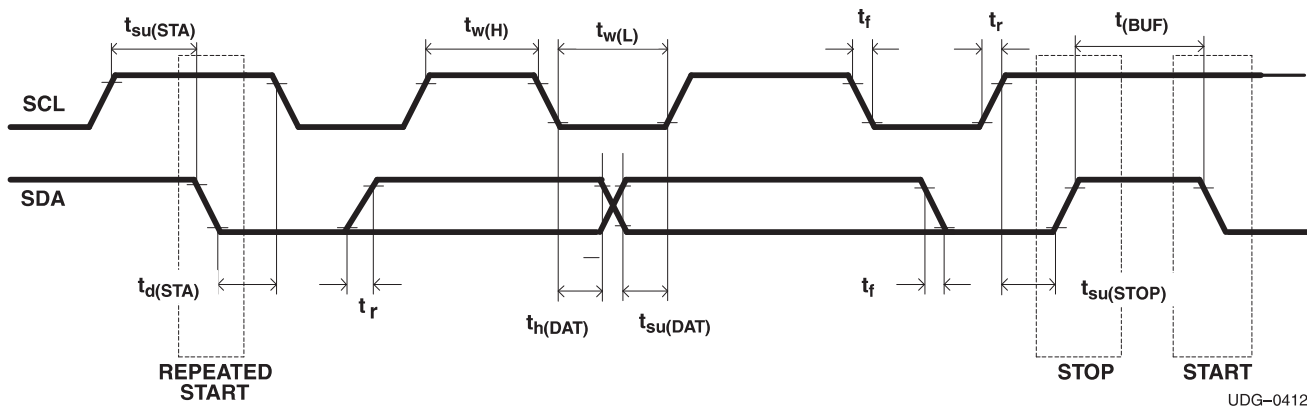

UDG-04122

Figure 3-1. I<sup>2</sup>C-Compatible Interface Timing Diagrams

## 4 GENERAL DESCRIPTION

The bq27620-G1 accurately predicts the battery capacity and other operational characteristics of a single Li-based rechargeable cell. It can be interrogated by a system processor to provide cell information, such as time-to-empty (TTE), time-to-full (TTF) and state-of-charge (SOC) as well as SOC interrupt signal to the host.

Information is accessed through a series of commands, called *Standard Commands*. Further capabilities are provided by the additional *Extended Commands* set. Both sets of commands, indicated by the general format *Command*( ), are used to read and write information contained within the device control and status registers, as well as its data flash locations. Commands are sent from system to gauge using the bq27620-G1's I<sup>2</sup>C serial communications engine, and can be executed during application development, system manufacture, or end-equipment operation.

Cell information is stored in the device in non-volatile flash memory. Many of these data flash locations are accessible during application development. They cannot, generally, be accessed directly during end-equipment operation. Access to these locations is achieved by either use of the bq27620-G1's companion evaluation software, through individual commands, or through a sequence of data-flash-access commands. To access a desired data flash location, the correct data flash subclass and offset must be known.

The bq27620-G1 provides a 32-byte user-programmable data flash **Manufacturer Info Block**. This data space is accessed through a data flash interface. For specifics on accessing the data flash, [MANUFACTURER INFORMATION BLOCKS](#).

The key to the bq27620-G1's high-accuracy gas gauging prediction is Texas Instrument's proprietary Impedance Track™ algorithm with Dynamic Voltage Correlation (IT-DVC). This algorithm uses cell measurements, characteristics, and properties to create state-of-charge predictions that can achieve less than 5% error across a wide variety of operating conditions and over the lifetime of the battery.

The device utilizes a comprehensive battery model to estimate the average current in real time, eliminating the need of a sense resistor. When a cell is attached to the device, cell impedance is computed, open-circuit voltage (OCV), and cell voltage under loading conditions.

The device external temperature sensing is optimized with the use of a high accuracy negative temperature coefficient (NTC) thermistor with R25 = 10.0kΩ ±1%. B25/85 = 3435K ± 1% (such as Semitec NTC 103AT). The bq27620-G1 can also be configured to use its internal temperature sensor. When an external thermistor is used, a 18.2k pull up resistor between BT/TOUT and TS pins is also required. The bq27620-G1 uses temperature to monitor the battery-pack environment, which is used for fuel gauging and cell protection functionality.

To minimize power consumption, the device has different power modes: NORMAL, SLEEP, HIBERNATE, and BAT INSERT CHECK. The bq27620-G1 passes automatically between these modes, depending upon the occurrence of specific events, though a system processor can initiate some of these modes directly. More details can be found in [POWER MODES](#).

---

### NOTE

#### FORMATTING CONVENTIONS IN THIS DOCUMENT:

Commands: *italics* with parentheses and no breaking spaces, e.g., *RemainingCapacity*( )

Data flash: *italics*, **bold**, and *breaking spaces*, e.g., **Design Capacity**

Register bits and flags: brackets and *italics*, e.g., [TDA]

Data flash bits: brackets, *italics* and **bold**, e.g., [LED1]

Modes and states: ALL CAPITALS, e.g., UNSEALED mode.

---

## 4.1 DATA COMMANDS

### 4.1.1 STANDARD DATA COMMANDS

The bq27620-G1 uses a series of 2-byte standard commands to enable system reading and writing of battery information. Each standard command has an associated command-code pair, as indicated in [Table 4-1](#). Because each command consists of two bytes of data, two consecutive I<sup>2</sup>C transmissions must be executed both to initiate the command function, and to read or write the corresponding two bytes of data. Additional options for transferring data, such as spooling, are described in Section of **Communication**. Read/Write permissions depend on the active access mode, SEALED or UNSEALED (for details on the SEALED and UNSEALED states, see [Section 4.4](#), Access Modes.)

**Table 4-1. Standard Commands**

NAME		COMMAND CODE	UNITS	SEALED ACCESS
<i>Control()</i>	CNTL	0x00 / 0x01	N/A	R/W
<i>AtRate()</i>		0x02 / 0x03	mA	R/W
<i>AtRateTimeToEmpty()</i>		0x04 / 0x05	Minutes	R
<i>Temperature()</i>	TEMP	0x06 / 0x07	0.1 K	R/W
<i>Voltage()</i>	VOLT	0x08 / 0x09	mV	R
<i>Flags()</i>	FLAGS	0x0a / 0x0b	N/A	R
<i>NominalAvailableCapacity()</i>		0x0c / 0x0d	mAh	R
<i>FullAvailableCapacity()</i>		0x0e / 0x0f	mAh	R
<i>RemainingCapacity()</i>	RM	0x10 / 0x11	mAh	R
<i>FullChargeCapacity()</i>	FCC	0x12 / 0x13	mAh	R
<i>EffectiveCurrent()</i>		0x14 / 0x15	mA	R
<i>TimeToEmpty()</i>		0x16 / 0x17	Minutes	R
<i>TimeToFull()</i>		0x18 / 0x19	Minutes	R
<i>StandbyCurrent()</i>		0x1a / 0x1b	mA	R
<i>StandbyTimeToEmpty()</i>		0x1c / 0x1d	Minutes	R
<i>MaxLoadCurrent()</i>		0x1e / 0x1f	mA	R
<i>MaxLoadTimeToEmpty()</i>		0x20 / 0x21	Minutes	R
<i>AvailableEnergy()</i>		0x22 / 0x23	mWh	R
<i>AveragePower()</i>		0x24 / 0x25	mW	R
<i>TTEatConstantPower()</i>		0x26 / 0x27	Minutes	R
<i>StateOfHealth()</i>	SOH	0x28 / 0x29	% / num	R
<i>CycleCount()</i>		0x2A / 0x2B	num	R
<i>StateOfCharge()</i>	SOC	0x2c / 0x2d	%	R
<i>InternalTemperature()</i>		0x36 / 0x37	0.1 K	R
<i>OperationConfiguration()</i>		0x3A / 0x3B	N/A	R
<i>ApplicationStatus()</i>		0x6A / 0x6B	N/A	R

#### 4.1.1.1 *Control()*: 0x00/0x01

Issuing a *Control()* command requires a subsequent 2-byte subcommand. These additional bytes specify the particular control function desired. The *Control()* command allows the system to control specific features of the bq27620-G1 during normal operation and additional features when the device is in different access modes, as described in [Table 4-2](#).

**Table 4-2. *Control()* Subcommands**

CNTL FUNCTION	CNTL DATA	SEALED ACCESS	DESCRIPTION
CONTROL_STATUS	0x0000	Yes	Reports the status of DF checksum, hibernate, IT, etc.
DEVICE_TYPE	0x0001	Yes	Reports the device type in hex digits. (type = 0x0620)
FW_VERSION	0x0002	Yes	Reports the firmware version on the device type
HW_VERSION	0x0003	Yes	Reports the hardware version of the device type
PREV_MACWRITE	0x0007	Yes	Returns previous MAC subcommand code
CHEM_ID	0x0008	Yes	Reports the chemical identifier of the Impedance Track™ configuration
OCV_CMD	0x000c	Yes	Request the gauge to take a OCV measurement
BAT_INSERT	0x000d	Yes	Forces the BAT_DET bit set when the [BIE] bit is 0
BAT_REMOVE	0x000e	Yes	Forces the BAT_DET bit clear when the [BIE] bit is 0
SET_HIBERNATE	0x0011	Yes	Forces CONTROL_STATUS [HIBERNATE] to 1
CLEAR_HIBERNATE	0x0012	Yes	Forces CONTROL_STATUS [HIBERNATE] to 0
DF_VERSION	0x001F	Yes	Returns the <b>Data Flash Version</b> code
SEALED	0x0020	No	Places the bq27620-G1 in SEALED access mode
OPTIMIZ	0x0030	No	Sets the OPTIMIZ bit and enables the optimization cycle
RESET	0x0041	No	Forces a full reset of the bq27620-G1

#### 4.1.1.1.1 CONTROL\_STATUS: 0x0000

Instructs the fuel gauge to return status information to control addresses 0x00/0x01. The status word includes the following information.

**Table 4-3. CONTROL\_STATUS Bit Definitions**

	bit7	bit6	bit5	bit4	bit3	bit2	bit1	bit0
High byte	-	FAS	SS	RSVD	-	-	OCVCMDCOMP	OCVFAIL
Low byte	INITCOMP	HIBERNATE	RLearn	SLEEP	LDMD	RUP_DIS	VOK	OPTMIZ

FAS = Status bit indicating the bq27620-G1 is in FULL ACCESS SEALED state. Active when set.

SS = Status bit indicating the bq27620-G1 is in SEALED state. Active when set.

OCVCMDCOMP = Status bit indicating the bq27620-G1 has executed the OCV command. This bit can only be set with battery's presence. True when set.

OCVFAIL = Status bit indicating bq27620-G1 OCV reading is failed due to the current. This bit can only be set with battery's presence. True when set.

INITCOMP = Initialization completion bit indicating the initialization completed. This bit can only be set with battery's presence. True when set.

HIBERNATE = Status bit indicating a request for entry into HIBERNATE from SLEEP mode. True when set. Default is 0.

RLearn = Indicates that resistance has been learned. True when set.

LDMD = Status bit indicating the bq27620-G1 Impedance Track™ algorithm is using constant-power mode. True when set. Default is 0 (constant-current mode).

RUP\_DIS = Status bit indicating the bq27620-G1 Ra table updates are disabled. Updates disabled when set.

VOK = Status bit indicating that a relaxed OCV measurement has occurred, always clears at the onset of charge or discharge currents. True when set.

OPTMIZ = Status bit indicating the bq27620-G1 is in an optimization mode; when set the gauge is in its optimization mode of operation for determining Qmax. True when set.

#### 4.1.1.1.2 DEVICE\_TYPE: 0x0001

Instructs the fuel gauge to return the device type to addresses 0x00/0x01.

#### 4.1.1.1.3 FW\_VERSION: 0x0002

Instructs the fuel gauge to return the firmware version to addresses 0x00/0x01. Refer to *Available Options* for the expected data value.

#### 4.1.1.1.4 HW\_VERSION: 0x0003

Instructs the fuel gauge to return the hardware version to addresses 0x00/0x01.

#### 4.1.1.1.5 PREV\_MACWRITE: 0x0007

Instructs the fuel gauge to return the previous subcommand written to addresses 0x00/0x01. **Note:** This subcommand is only supported for previous subcommand codes 0x0000 through 0x0014. For subcommand codes greater than 0x0009, a value of 0x0007 is returned.

#### 4.1.1.1.6 CHEM\_ID: 0x0008

Instructs the fuel gauge to return the chemical identifier for the Impedance Track™ configuration to addresses 0x00/0x01.

#### 4.1.1.1.7 OCV\_CMD: 0X000C

This command is to request the gauge to take a OCV reading. This command can only be issued after the *[INITCOMP]* has been set, indicating the initialization has been completed. The OCV measurement take place at the beginning of the next repeated 1s firmware synchronization clock. During the same time period, the SOC\_INT will pulse. The host should use this signal to reduce the load current below the C/20 in 8ms for a valid OCV reading. The OCV command *[OCVFAIL]* bit will be set if the OCV\_CMD is issued when *[CHG\_INH]* is set.

#### 4.1.1.1.8 **BAT\_INSERT: 0X000D**

This command is to force the BAT\_DET bit to be set when the battery insertion detection is disabled. When the BIE is set to 0, the battery insertion detection is disabled. The gauge relies on the host to inform the battery insertion with this command to set the BAT\_DET bit.

#### 4.1.1.1.9 **BAT\_REMOVE: 0X000E**

This command is to force the BAT\_DET bit to be clear when the battery insertion detection is disabled. When the BIE is set to 0, the battery insertion detection is disabled. The gauge relies on the host to inform it of the battery removal with this command to clear the BAT\_DET bit.

#### 4.1.1.1.10 **SET\_HIBERNATE: 0x0011**

Instructs the fuel gauge to force the CONTROL\_STATUS [*HIBERNATE*] bit to 1. This will allow the gauge to enter the HIBERNATE power mode after the transition to SLEEP power state is detected. The [*HIBERNATE*] bit is automatically cleared upon exiting from HIBERNATE mode.

#### 4.1.1.1.11 **CLEAR\_HIBERNATE: 0x0012**

Instructs the fuel gauge to force the CONTROL\_STATUS [*HIBERNATE*] bit to 0. This prevents the gauge from entering the HIBERNATE power mode after the transition to the SLEEP power state is detected. It can also be used to force the gauge out of HIBERNATE mode.

#### 4.1.1.1.12 **DF\_VERSION: 0x001F**

Instructs the fuel gauge to return the 16-bit data flash revision code to addresses 0x00/0x01. The code is stored in **Data Flash Version** and provides a simple method for the customer to control data flash revisions. The default DF\_VERSION is 0x0000.

#### 4.1.1.1.13 **SEALED: 0x0020**

Instructs the fuel gauge to transition from the UNSEALED state to the SEALED state. The fuel gauge must always be set to the SEALED state for use in end equipment.

#### 4.1.1.1.14 **OPTIMIZ: 0x0030**

This MAC command should be issued at the end of full charge cycle before the full discharge cycle begins. This command will set bit 0 (OPTMIZ) of the Control/Status register. When the bit is set and the gauge detects discharge it will stop using estimated current for Q measurement. Instead it will use DataFlash IT.LearnCurrent and accumulate charge using that current until discharge termination is detected from the current estimation engine. At that point the current used by the gauge defaults to zero mA. This command is only available when the fuel gauge is UNSEALED.

#### 4.1.1.1.15 **RESET: 0x0041**

This command instructs the fuel gauge to perform a full reset. This command is only available when the fuel gauge is UNSEALED.

#### 4.1.1.2 **AtRateTimeToEmpty(): 0x04/0x05**

This read-word function returns an unsigned integer value of the predicted remaining operating time if the battery is discharged at the *AtRate()* value in minutes with a range of 0 to 65,534. A value of 65,535 indicates *AtRate()* = 0. The fuel gauge updates *AtRateTimeToEmpty()* within 1 s after the system sets the *AtRate()* value. The fuel gauge automatically updates *AtRateTimeToEmpty()* based on the *AtRate()* value every 1 s. Both the *AtRate()* and *AtRateTimeToEmpty()* commands must only be used in NORMAL mode.

#### 4.1.1.3 *Temperature()*: 0x06/0x07

This read/write-word function returns an unsigned integer value of the temperature in units of 0.1 K measured by the fuel gauge. If *[WRTEMP]* bit = 1, a write command sets the temperature to be used for gauging calculations while a read command returns to temperature previously written. If *[WRTEMP]* bit = 0 and *[TEMPS]* bit = 0, a read command will return the internal temperature sensor value.

#### 4.1.1.4 *Voltage()*: 0x08/0x09

This read-word function returns an unsigned integer value of the measured cell-pack voltage in mV with a range of 0 to 6000 mV.

#### 4.1.1.5 *Flags()*: 0x0a/0x0b

This read-word function returns the contents of the fuel-gauge status register, depicting the current operating status.

**Table 4-4. Flags Bit Definitions**

	bit7	bit6	bit5	bit4	bit3	bit2	bit1	bit0
High byte	OTC	OTD	–	CALEN	CHG_INH	XCHG	FC	CHG
Low byte	–	–	OCVGD	NEEDID	BATTDDET	SOC1	SYSDOWN	DSG

OTC = Overtemperature in charge condition is detected. True when set. SOC\_INT will toggle once if set.

OTD = Overtemperature in discharge condition is detected. True when set. SOC\_INT will toggle once if set.

CALEN = Status bit indicating the calibration function is enabled. True when set.

CHG\_INH = Charge inhibit: unable to begin charging (temperature outside the range [*Charge Inhibit Temp Low, Charge Inhibit Temp High*]). True when set.

XCHG = Charge suspend alert (temperature outside the range [*Suspend Temperature Low, Suspend Temperature High*]). True when set.

FC = Full-charged condition reached. Set when charge termination condition is met. (RMFCC=1; Set FC\_Set % = -1% when RMFCC = 0). True when set

CHG = (Fast) charging allowed. True when set.

OCVGD = Good OCV measurement taken. True when set.

NEEDID = Waiting to identify inserted battery. True when set.

BATTDDET = Battery detected. True when set.

SOC1 = State-of-charge threshold 1 (**SOC1 Set**) reached. The flag is enabled when BL\_INT bit in **Operation Configuration B** is set. True when set.

SysDown = SystemDown bit indicating the system shut down. SOC\_INT will toggle once if set.

DSG = Discharging detected. True when set.

#### 4.1.1.6 *NominalAvailableCapacity()*: 0x0c/0x0d

This read-only command pair returns the uncompensated (less than C/20 load) battery capacity remaining. Units are mAh.

#### 4.1.1.7 *FullAvailableCapacity()*: 0x0e/0x0f

This read-only command pair returns the uncompensated (less than C/20 load) capacity of the battery when fully charged. Units are mAh. *FullAvailableCapacity()* is updated at regular intervals, as specified by the IT algorithm.

#### 4.1.1.8 *RemainingCapacity()*: 0x10/0x11

This read-only command pair returns the remaining battery capacity which is compensated for the present conditions of load, temperature and battery age. *RemainingCapacity()* is typically lower than the uncompensated *NominalAvailableCapacity()*. Units are mAh.

#### 4.1.1.9 *FullChargeCapacity()*: 0x12/13

This read-only command pair returns the capacity of the battery when fully charged with compensation for the present conditions of temperature and battery age. *FullChargeCapacity()* is updated at regular intervals, as specified by the IT algorithm typically lower than the uncompensated *FullAvailableCapacity()* and . Units are mAh.

#### 4.1.1.10 **EffectiveCurrent( )**: 0x14/0x15

This read-only command pair returns a signed integer value that is taken from the Effective current Calculation being used by DVC algorithm. Units are mA.

#### 4.1.1.11 **TimeToEmpty( )**: 0x16/0x17

This read-only function returns an unsigned integer value of the predicted remaining battery life at the present rate of discharge, in minutes. A value of 65,535 indicates battery is not being discharged.

#### 4.1.1.12 **TimeToFull( )**: 0x18/0x19

This read-only function returns an unsigned integer value of predicted remaining time until the battery reaches full charge, in minutes, based upon *EffectiveCurrent( )*. The computation accounts for the taper current time extension from the linear TTF computation based on a fixed *EffectiveCurrent( )* rate of charge accumulation. A value of 65,535 indicates the battery is not being charged.

#### 4.1.1.13 **StandbyCurrent( )**: 0x1a/0x1b

This read-only function returns a signed integer value of the measured standby current from the Effective Current Calculation. The *StandbyCurrent( )* is an adaptive measurement. Initially it reports the standby current programmed in **Initial Standby**, and after spending several seconds in standby, reports the measured standby current.

The register value is updated every 1 second when the effective current is above the **Deadband** and is less than or equal to  $2 \times$  **Initial Standby**. The first and last values that meet this criteria are not averaged in, since they may not be stable values. To approximate a 1 minute time constant, each new *StandbyCurrent( )* value is computed by taking approximate 93% weight of the last standby current and approximate 7% of the effective current calculation.

#### 4.1.1.14 **StandbyTimeToEmpty( )**: 0x1c/0x1d

This read-only function returns an unsigned integer value of the predicted remaining battery life at the standby rate of discharge, in minutes. The computation uses *Nominal Available Capacity* (NAC), the uncompensated remaining capacity, for this computation. A value of 65,535 indicates battery is not being discharged.

#### 4.1.1.15 **MaxLoadCurrent( )**: 0x1e/0x1f

This read-only function returns a signed integer value, in units of mA, of the maximum load conditions. The *MaxLoadCurrent( )* is an adaptive measurement which is initially reported as the maximum load current programmed in *Initial Max Load Current*. If the effective current calculation is ever greater than *Initial Max Load Current*, then *MaxLoadCurrent( )* updates to the new current calculation. *MaxLoadCurrent( )* is reduced to the average of the previous value and *Initial Max Load Current* whenever the battery is charged to full after a previous discharge to an SOC less than 50%. This prevents the reported value from maintaining an unusually high value.

#### 4.1.1.16 **MaxLoadTimeToEmpty( )**: 0x20/0x21

This read-only function returns an unsigned integer value of the predicted remaining battery life at the maximum load current discharge rate, in minutes. A value of 65,535 indicates that the battery is not being discharged.

#### 4.1.1.17 **AvailableEnergy( )**: 0x22/0x23

This read-only function returns an unsigned integer value of the predicted charge or energy remaining in the battery. The value is reported in units of mWh.

#### 4.1.1.18 **AveragePower( ):** 0x24/0x25

This read-only function returns a signed integer value of the average power during battery charging and discharging. It is negative during discharge and positive during charge. A value of 0 indicates that the battery is not being discharged. The value is reported in units of mW.

#### 4.1.1.19 **TimeToEmptyAtConstantPower( ):** 0x26/0x27

This read-only function returns an unsigned integer value of the predicted remaining operating time if the battery is discharged at the *AveragePower( )* value in minutes. A value of 65,535 indicates *AveragePower( )* = 0. The fuel gauge automatically updates *TimeToEmptyatContantPower( )* based on the *AveragePower( )* value every 1 s.

#### 4.1.1.20 **StateofHealth( ):** 0x28/0x29

0x28 SOH percentage: this read-only function returns an unsigned integer value, expressed as a percentage of the ratio of predicted *FCC(25°C, SOH LoadI)* over the *DesignCapacity( )*. The *FCC(25°C, SOH LoadI)* is the calculated full charge capacity at 25°C and the *SOH LoadI* which is specified in the data flash. The range of the returned SOH percentage is 0x00 to 0x64, indicating 0 to 100% correspondingly.

0x29 SOH Status: this read-only function returns an unsigned integer value, indicating the status of the SOH percentage. The meanings of the returned value are:

- 0x00: SOH not valid (initialization)
- 0x01: SOH initial value for unidentified pack
- 0x02: SOH final value, pack identified

#### 4.1.1.21 **CycleCount( ):** 0x2a/0x2b

This read-only function returns an unsigned integer value of the number of cycles that the active cell has experienced with a range of 0 to 65535. One cycle occurs when accumulated discharge  $\geq$  **CC Threshold**. The gauge maintains a separate cycle counter for both cell profiles and will reset to zero if the insertion of a new pack has been detected.

#### 4.1.1.22 **StateOfCharge( ):** 0x2c/0x2d

This read-only function returns an unsigned integer value of the predicted remaining battery capacity expressed as a percentage of *FullChargeCapacity( )*, with a range of 0 to 100%.

#### 4.1.1.23 **InternalTemperature( ):** 0x36/0x37

This read-only function returns an unsigned integer value of the internal temperature sensor in units of 0.1 K measured by the fuel gauge. This function can be useful as an additional system-level temperature monitor if the main *Temperature( )* function is configured for external or host reported temperature.

#### 4.1.1.24 **OperationConfiguration( ):** 0x3a/0x3b

This read-only function returns the contents of the data flash **Operation Configuration** register and is most useful for system level debug to quickly determine device configuration.

#### 4.1.1.25 **ApplicationStatus():** 0x6a/0x6b

This read-only function returns the contents of the data flash Host Cfg register.

## 4.1.2 EXTENDED DATA COMMANDS

Extended commands offer additional functionality beyond the standard set of commands. They are used in the same manner; however, unlike standard commands, extended commands are not limited to 2-byte words. The number of commands bytes for a given extended command ranges in size from single to multiple bytes, as specified in [Table 4-5](#).

**Table 4-5. Extended Data Commands**

NAME	COMMAND CODE	UNITS	SEALED ACCESS <sup>(1)</sup> (2)	UNSEALED ACCESS <sup>(1)</sup> (2)
Reserved	0x34...0x3b	N/A	R	R
<i>DesignCapacity()</i>	0x3c / 0x3d	mAh	R	R
<i>DataFlashClass()</i> <sup>(2)</sup>	0x3e	N/A	N/A	R/W
<i>DataFlashBlock()</i> <sup>(2)</sup>	0x3f	N/A	R/W	R/W
<i>BlockData()</i>	0x40...0x5f	N/A	R	R/W
<i>BlockDataChecksum()</i>	0x60	N/A	R/W	R/W
<i>BlockDataControl()</i>	0x61	N/A	N/A	R/W
<i>ApplicationStatus()</i>	0x6a	N/A	R	R
Reserved	0x6b...0x7f	N/A	R	R

(1) SEALED and UNSEALED states are entered via commands to **Control()** 0x00/0x01.

(2) In sealed mode, data flash CANNOT be accessed through commands 0x3e and 0x3f.

### 4.1.2.1 *DesignCapacity()*: 0x3c/0x3d

**SEALED and UNSEALED Access:** This command returns the value is stored in **Design Capacity** and is expressed in mAh. This is intended to be the theoretical or nominal capacity of a new pack, but has no bearing on the operation of the fuel gauge functionality.

### 4.1.2.2 *DataFlashClass()*: 0x3e

**UNSEALED Access:** This command sets the data flash class to be accessed. The class to be accessed must be entered in hexadecimal.

**SEALED Access:** This command is not available in SEALED mode.

### 4.1.2.3 *DataFlashBlock()*: 0x3f

**UNSEALED Access:** This command sets the data flash block to be accessed. When 0x00 is written to *BlockDataControl()*, *DataFlashBlock()* holds the block number of the data flash to be read or written. Example: writing a 0x00 to *DataFlashBlock()* specifies access to the first 32-byte block, a 0x01 specifies access to the second 32-byte block, and so on.

**SEALED Access:** This command directs which data flash block is accessed by the *BlockData()* command. Writing a 0x01 or 0x02 instructs the *BlockData()* command to transfer the **Manufacturer Info Block**. All other *DataFlashBlock()* values are reserved.

### 4.1.2.4 *BlockData()*: 0x40...0x5f

**UNSEALED Access:** This data block is the remainder of the 32 byte data block when accessing data flash.

**SEALED Access:** This data block is the remainder of the 32 byte data block when accessing **Manufacturer Block Info**.

### 4.1.2.5 *BlockDataChecksum()*: 0x60

**UNSEALED Access:** This byte contains the checksum on the 32 bytes of block data read or written to data flash. The least-significant byte of the sum of the data bytes written must be complemented ( $[255 - x]$ , for  $x$  the least-significant byte) before being written to 0x60.

**SEALED Access:** This byte contains the checksum for the 32 bytes of block data written to *the Manufacturer Info Block*. The least-significant byte of the sum of the data bytes written must be complemented ( $[255 - x]$ , for  $x$  the least-significant byte) before being written to 0x60.

#### 4.1.2.6 *BlockDataControl()*: 0x61

**UNSEALED Access:** This command is used to control data flash access mode. Writing 0x00 to this command enables *BlockData()* to access general data flash. Writing a 0x01 to this command enables SEALED mode operation of *DataFlashBlock()*.

**SEALED Access:** This command is not available in SEALED mode.

#### 4.1.2.7 *ApplicationStatus()*: 0x6a

This byte function allows the system to read the bq27620-G1 Host Cfg data flash location. See [Table 6-1](#) for specific bit definitions.

#### 4.1.2.8 **Reserved** — 0x6b–0x7f

## 4.2 DATA FLASH INTERFACE

### 4.2.1 ACCESSING THE DATA FLASH

The bq27620-G1 data flash is a non-volatile memory that contains bq27620-G1 initialization, default, cell status, calibration, configuration, and user information. The data flash can be accessed in several different ways, depending on what mode the bq27620-G1 is operating in and what data is being accessed.

Commonly accessed data flash memory locations, frequently read by a system, are conveniently accessed through specific instructions, already described in [Section 4.1, DATA COMMANDS](#). These commands are available when the bq27620-G1 is either in UNSEALED or SEALED modes.

Most data flash locations, however, are only accessible in UNSEALED mode by use of the bq27620-G1 evaluation software or by data flash block transfers. These locations should be optimized and/or fixed during the development and manufacture processes. They become part of a golden image file and can then be written to multiple battery packs. Once established, the values generally remain unchanged during end-equipment operation.

To access data flash locations individually, the block containing the desired data flash location(s) must be transferred to the command register locations, where they can be read to the system or changed directly. This is accomplished by sending the set-up command *BlockDataControl()* (0x61) with data 0x00. Up to 32 bytes of data can be read directly from the *BlockData()* (0x40...0x5f), externally altered, then rewritten to the *BlockData()* command space. Alternatively, specific locations can be read, altered, and rewritten if their corresponding offsets are used to index into the *BlockData()* command space. Finally, the data residing in the command space is transferred to data flash, once the correct checksum for the whole block is written to *BlockDataChecksum()* (0x60).

Occasionally, a data flash CLASS will be larger than the 32-byte block size. In this case, the *DataFlashBlock()* command is used to designate which 32-byte block the desired locations reside in. The correct command address is then given by  $0x40 + \text{offset} \textit{ modulo } 32$ . For example, to access **Terminate Voltage** in the *Gas Gauging* class, *DataFlashClass()* is issued 80 (0x50) to set the class. Because the offset is 44, it must reside in the second 32-byte block. Hence, *DataFlashBlock()* is issued 0x01 to set the block offset, and the offset used to index into the *BlockData()* memory area is  $0x40 + 44 \textit{ modulo } 32 = 0x40 + 12 = 0x40 + 0x0C = 0x4C$ .

Reading and writing subclass data are block operations up to 32 bytes in length. If during a write the data length exceeds the maximum block size, then the data is ignored.

None of the data written to memory are bounded by the bq27620-G1 – the values are not rejected by the fuel gauge. Writing an incorrect value may result in hardware failure due to firmware program interpretation of the invalid data. The written data is persistent, so a power-on reset does resolve the fault.

### 4.3 MANUFACTURER INFORMATION BLOCK

The bq27620-G1 contains 32 bytes of user programmable data flash storage called the **Manufacturer Info Block**. The method for accessing these memory locations is slightly different, depending on whether the device is in UNSEALED or SEALED modes.

When in UNSEALED mode and when 0x00 has been written to *BlockDataControl()*, accessing the manufacturer information blocks is identical to accessing general data flash locations. First, a *DataFlashClass()* command is used to set the subclass, then a *DataFlashBlock()* command sets the offset for the first data flash address within the subclass. The *BlockData()* command codes contain the referenced data flash data. When writing the data flash, a checksum is expected to be received by *BlockDataChecksum()*. Only when the checksum is received and verified is the data actually written to data flash.

When in SEALED mode or when 0x01 *BlockDataControl()* does not contain 0x00, data flash is no longer available in the manner used in UNSEALED mode. Rather than issuing subclass information, a designated Manufacturer Information Block is selected with the *DataFlashBlock()* command. Issuing a 0x01 or 0x02 with this command causes the corresponding information block to be transferred to the command space 0x40...0x5f for editing or reading by the system. Upon successful writing of checksum information to *BlockDataChecksum()*, the modified block is returned to data flash. **Note: The Manufacturer Info Block** is read-only when in SEALED mode.

#### 4.4 ACCESS MODES

The bq27620-G1 provides three security modes (FULL ACCESS, UNSEALED, and SEALED) that control data flash access permissions, according to [Table 4-6](#). *Data Flash* refers to those data flash locations, specified in [Section 4.6](#), that are accessible to the user.

**Table 4-6. Data Flash Access**

Security Mode	Data Flash	Manufacture Info Block
FULL ACCESS	R/W	R/W
UNSEALED	R/W	R/W
SEALED	None	R

Although FULL ACCESS and UNSEALED modes appear identical, only FULL ACCESS allows the bq27620-G1 to write access-mode transition keys.

#### 4.5 SEALING/UNSEALING DATA FLASH

The bq27620-G1 implements a key-access scheme to transition between SEALED, UNSEALED, and FULL-ACCESS modes. Each transition requires that a unique set of two keys be sent to the bq27620-G1 via the *Control()* control command. The keys must be sent consecutively, with no other data being written to the *Control()* register in between. Note that to avoid conflict, the keys must be different from the codes presented in the *CNTL DATA* column of [Table 4-2](#) subcommands.

When in SEALED mode, the CONTROL\_STATUS [SS] bit is set, but when the UNSEAL keys are correctly received by the bq27620-G1, the [SS] bit is cleared. When the full-access keys are correctly received, then the CONTROL\_STATUS [FAS] bit is cleared.

Both the sets of keys for each level are 2 bytes each in length and are stored in data flash. The UNSEAL key (stored at **Unseal Key 0** and **Unseal Key 1**) and the FULL-ACCESS key (stored at **Full-Access Key 0** and **Full-Access Key 1**) can only be updated when in FULL-ACCESS mode. The order of the keys is **Key 1** followed by **Key 0**. The order of the bytes entered through the *Control()* command is the reverse of what is read from the part. For example, if the **Key 1** and **Key 0** of the **Unseal Keys** returns 0x1234 and 0x5678, then the *Control()* should supply 0x3412 and 0x7856 to unseal the part.

## 4.6 DATA FLASH SUMMARY

The following table summarizes the data flash locations available to the user, including their default, minimum, and maximum values.

**Table 4-7. Data Flash Summary**

Class	Subclass ID	Subclass	Offset	Name	Data Type	Min Value	Max Value	Default Value	Units (EVSW Units)*
Configuration	2	Safety	0	OT Chg	I2	0	1200	550	0.1°C
Configuration	2	Safety	2	OT Chg Time	U1	0	60	2	s
Configuration	2	Safety	3	OT Chg Recovery	I2	0	1200	500	0.1°C
Configuration	2	Safety	5	OT Dsg	I2	0	1200	600	0.1°C
Configuration	2	Safety	7	OT Dsg Time	U1	0	60	2	s
Configuration	2	Safety	8	OT Dsg Recovery	I2	0	1200	550	0.1°C
Configuration	32	Charge Inhibit Cfg	0	Chg Inhibit Temp Low	I2	-400	1200	0	0.1°C
Configuration	32	Charge Inhibit Cfg	2	Chg Inhibit Temp High	I2	-400	1200	450	0.1°C
Configuration	32	Charge Inhibit Cfg	4	Temp Hys	I2	0	100	50	0.1°C
Configuration	34	Charge	0	Charging Voltage	I2	0	4600	4200	mV
Configuration	34	Charge	2	Delta Temp	I2	0	500	50	0.1°C
Configuration	34	Charge	4	Suspend Low Temp	I2	-400	1200	-50	0.1°C
Configuration	34	Charge	6	Suspend High Temp	I2	-400	1200	550	0.1°C
Configuration	36	Charge Termination	0	Taper Current	I2	0	1000	100	mA
Configuration	36	Charge Termination	2	Min Taper Capacity	I2	0	1000	25	mAh
Configuration	36	Charge Termination	4	Taper Voltage	I2	0	1000	100	mV
Configuration	36	Charge Termination	6	Current Taper Window	U1	0	60	40	s
Configuration	36	Charge Termination	9	FC Set %	I1	-1	100	-1	%
Configuration	36	Charge Termination	10	FC Clear %	I1	-1	100	98	%
Configuration	36	Charge Termination	11	DODatEOC Delta T	I2	0	1000	50	0.1°C
Configuration	48	Data	0	Initial Standby	I1	-256	0	-10	mA
Configuration	48	Data	1	Initial MaxLoad	I2	-32767	0	-750	mA
Configuration	48	Data	3	CC Threshold	I2	100	32767	1050	mAh
Configuration	48	Data	6	Design Capacity	I2	0	32767	1140	mA
Configuration	48	Data	10	Design Voltage	I2	0	32767	3600	MilliVolt
Configuration	48	Data	12	SOH LoadI	I2	-32767	0	-400	mA
Configuration	48	Data	14	Default Temp	I2	0	3050	2982	°K
Configuration	48	Data	16	Data Flash Version	H2	0x0000	0xffff	0x0000	
Configuration	48	Data	18	Device Name	S8	x	x	bq27620	-
Configuration	49	Discharge	0	SOC1 Set Threshold	U1	0	255	150	mA
Configuration	49	Discharge	1	SOC1 Clear Threshold	U1	0	255	175	mA
Configuration	49	Discharge	5	SysDown Set Volt Threshold	I2	0	4200	3150	mV
Configuration	49	Discharge	7	SysDown Set Volt Time	U1	0	60	2	s
Configuration	49	Discharge	8	SysDown Clear Volt	I2	0000	4200	3400	mV
Configuration	49	Discharge	15	Def Cell 0 DOD at EOC	I2	0	16384	0	
Configuration	49	Discharge	17	Def Avg I Last Run	I2	-32768	32767	-50	mA
Configuration	49	Discharge	19	Def Avg P Last Run	I2	-32768	32767	-50	mWatt
Configuration	64	Registers	0	Op Config	H2	0x0000	0xffff	0x0853	
Configuration	64	Registers	2	SOC Delta	U1	0	25	1	%
Configuration	64	Registers	3	i2c Timeout	U1	0	7	4	%
Configuration	64	Registers	4	DF Wr Ind Wait	U2	0	65535	0	%
Configuration	64	Registers	6	OpConfig B	H1	0x00	0xff	0x4b	
Configuration	64	Registers	7	OpConfig C	H1	0x00	0xff	0x28	
Configuration	64	Registers	8	Clk Ctl Reg	H1	0x00	0x0f	0x09	Hex
Configuration	68	Power	0	Flash Update OK Voltage	I2	0	4200	2800	mV
Configuration	68	Power	4	Sleep Current	I2	0	100	10	mA
Configuration	68	Power	6	Sleep Time	U1	0	100	20	s

**Table 4-7. Data Flash Summary (continued)**

Class	Subclass ID	Subclass	Offset	Name	Data Type	Min Value	Max Value	Default Value	Units (EVSW Units)*
Configuration	68	Power	7	Hibernate I	U2	0	700	8	mA
Configuration	68	Power	9	Hibernate V	U2	2400	3000	2550	mV
System Data	57	Manufacturer Info	0-31	Block [0-31]	H1	0x00	0xff	[Table]	-
Gas Gauging	80	IT Cfg	0	Load Select	U1	0	255	1	
Gas Gauging	80	IT Cfg	1	Load Mode	U1	0	255	0	
Gas Gauging	80	IT Cfg	21	Max Res Factor	U1	0	255	15	
Gas Gauging	80	IT Cfg	22	Min Res Factor	U1	0	255	5	
Gas Gauging	80	IT Cfg	24	Ra Filter	U2	0	1000	800	
Gas Gauging	80	IT Cfg	44	Terminate Voltage	I2	-32768	32767	3200	mV
Gas Gauging	80	IT Cfg	46	Term V Delta	I2	0	4200	200	mV
Gas Gauging	80	IT Cfg	49	ResRelax Time	U2	0	65534	500	s
Gas Gauging	80	IT Cfg	53	User Rate-mA	I2	-2000	-100	0	mA
Gas Gauging	80	IT Cfg	55	User Rate-mW	I2	-7200	-350	0	cW
Gas Gauging	80	IT Cfg	57	Reserve Cap-mAh	I2	0	9000	0	mA
Gas Gauging	80	IT Cfg	59	Reserve Cap-mWh	I2	0	14000	0	10mW
Gas Gauging	80	IT Cfg	64	Min Delta Voltage	I2	-32000	32000	0	
Gas Gauging	80	IT Cfg	68	Ra Max Delta	U2	0	65535	44	mΩ
Gas Gauging	80	IT Cfg	70	DeltaV Max dV	U2	0	65535	10	mV
Gas Gauging	80	IT Cfg	72	Max Res Scale	U2	0	32767	5000	Num
Gas Gauging	80	IT Cfg	74	Min Res Scale	U2	0	32767	200	Num
Gas Gauging	80	IT Cfg	76	Fast Scale Start SOC	U1	0	100	10	%
Gas Gauging	80	IT Cfg	83	LC Dection Sensitivity	U1	0	100	80	%
Gas Gauging	81	Current Thresholds	6	Dsg Relax Time	U2	0	8191	60	s
Gas Gauging	81	Current Thresholds	8	Chg Relax Time	U1	0	255	60	s
Gas Gauging	81	Current Thresholds	9	Quit Relax Time	U1	0	63	1	s
Gas Gauging	81	Current Thresholds	10	Transient Factor Charge	U1	0	255	128	
Gas Gauging	81	Current Thresholds	11	Transient Factor Discharge	U1	0	255	128	
Gas Gauging	81	Current Thresholds	12	Max IR Correct	U2	0	1000	400	mV
Gas Gauging	82	State	0	Host Cfg	H1	0x01	0xff	0x00	
Gas Gauging	82	State	1	Qmax Cell 0	I2	0	32767	16384	rate
Gas Gauging	82	State	3	Cycle Count0	U2	0	65535	0	
Gas Gauging	82	State	5	Qmax Cell 1	I2	0	32767	16384	rate
Gas Gauging	82	State	7	Cycle Count 1	U2	0	65535	0	
Gas Gauging	82	State	9	Chg DoD0 C 0	U2	0	65535	0	
Gas Gauging	82	State	11	Chg DoD0 C 1	U2	0	65535	0	
Gas Gauging	82	State	15	DoDatEOC	U2	0	65535	0	
Gas Gauging	82	State	25	T Rise	U2	0	65535	20	Num
Gas Gauging	82	State	27	T Time Constant	U2	0	65535	1000	Num
OCV Table	83	OCVa Table	0	Chem ID	H2	0x0000	0xffff	0x1124	hex
Default Ra Tables	85	Def Ra	0	Cell0 R_a flag	H1	0x00	0x00	0x55	-
Default Ra Tables	85	Def Ra	1	Cell0 R_a 0	I2	1	32767	424	2 <sup>-10</sup> Ω
Default Ra Tables	85	Def Ra	3	Cell0 R_a 1	I2	1	32767	509	2 <sup>-10</sup> Ω
Default Ra Tables	85	Def Ra	5	Cell0 R_a 2	I2	1	32767	538	2 <sup>-10</sup> Ω
Default Ra Tables	85	Def Ra	7	Cell0 R_a 3	I2	1	32767	535	2 <sup>-10</sup> Ω
Default Ra Tables	85	Def Ra	9	Cell0 R_a 4	I2	1	32767	461	2 <sup>-10</sup> Ω
Default Ra Tables	85	Def Ra	11	Cell0 R_a 5	I2	1	32767	460	2 <sup>-10</sup> Ω
Default Ra Tables	85	Def Ra	13	Cell0 R_a 6	I2	1	32767	509	2 <sup>-10</sup> Ω

**Table 4-7. Data Flash Summary (continued)**

Class	Subclass ID	Subclass	Offset	Name	Data Type	Min Value	Max Value	Default Value	Units (EVSW Units)*
Default Ra Tables	85	Def Ra	15	Cell0 R_a 7	I2	1	32767	578	2 <sup>-10</sup> Ω
Default Ra Tables	85	Def Ra	17	Cell0 R_a 8	I2	1	32767	563	2 <sup>-10</sup> Ω
Default Ra Tables	85	Def Ra	19	Cell0 R_a 9	I2	1	32767	544	2 <sup>-10</sup> Ω
Default Ra Tables	85	Def Ra	21	Cell0 R_a 10	I2	1	32767	574	2 <sup>-10</sup> Ω
Default Ra Tables	85	Def Ra	23	Cell0 R_a 11	I2	1	32767	726	2 <sup>-10</sup> Ω
Default Ra Tables	85	Def Ra	25	Cell0 R_a 12	I2	1	32767	956	2 <sup>-10</sup> Ω
Default Ra Tables	85	Def Ra	27	Cell0 R_a 13	I2	1	32767	1222	2 <sup>-10</sup> Ω
Default Ra Tables	85	Def Ra	29	Cell0 R_a 14	I2	1	32767	8099	2 <sup>-10</sup> Ω
Ra Table	88	R_a0	0	Cell0 R_a flag	H1	0x00	0x255	0x55	-
Ra Table	88	R_a0	1	Cell0 R_a 0	I2	1	32767	424	2 <sup>-10</sup> Ω
Ra Table	88	R_a0	3	Cell0 R_a 1	I2	1	32767	509	2 <sup>-10</sup> Ω
Ra Table	88	R_a0	5	Cell0 R_a 2	I2	1	32767	538	2 <sup>-10</sup> Ω
Ra Table	88	R_a0	7	Cell0 R_a 3	I2	1	32767	535	2 <sup>-10</sup> Ω
Ra Table	88	R_a0	9	Cell0 R_a 4	I2	1	32767	461	2 <sup>-10</sup> Ω
Ra Table	88	R_a0	11	Cell0 R_a 5	I2	1	32767	460	2 <sup>-10</sup> Ω
Ra Table	88	R_a0	13	Cell0 R_a 6	I2	1	32767	509	2 <sup>-10</sup> Ω
Ra Table	88	R_a0	15	Cell0 R_a 7	I2	1	32767	578	2 <sup>-10</sup> Ω
Ra Table	88	R_a0	17	Cell0 R_a 8	I2	1	32767	563	2 <sup>-10</sup> Ω
Ra Table	88	R_a0	19	Cell0 R_a 9	I2	1	32767	544	2 <sup>-10</sup> Ω
Ra Table	88	R_a0	21	Cell0 R_a 10	I2	1	32767	574	2 <sup>-10</sup> Ω
Ra Table	88	R_a0	23	Cell0 R_a 11	I2	1	32767	726	2 <sup>-10</sup> Ω
Ra Table	88	R_a0	25	Cell0 R_a 12	I2	1	32767	956	2 <sup>-10</sup> Ω
Ra Table	88	R_a0	27	Cell0 R_a 13	I2	1	32767	1222	2 <sup>-10</sup> Ω
Ra Table	88	R_a0	29	Cell0 R_a 14	I2	1	32767	8099	2 <sup>-10</sup> Ω
Ra Table	89	R_a1	0	Cell1 R_a flag	H1	0x00	0x255	0x55	-
Ra Table	89	R_a1	1	Cell1 R_a 0	I2	1	32767	424	2 <sup>-10</sup> Ω
Ra Table	89	R_a1	3	Cell1 R_a 1	I2	1	32767	509	2 <sup>-10</sup> Ω
Ra Table	89	R_a1	5	Cell1 R_a 2	I2	1	32767	538	2 <sup>-10</sup> Ω
Ra Table	89	R_a1	7	Cell1 R_a 3	I2	1	32767	535	2 <sup>-10</sup> Ω
Ra Table	89	R_a1	9	Cell1 R_a 4	I2	1	32767	461	2 <sup>-10</sup> Ω
Ra Table	89	R_a1	11	Cell1 R_a 5	I2	1	32767	460	2 <sup>-10</sup> Ω
Ra Table	89	R_a1	13	Cell1 R_a 6	I2	1	32767	509	2 <sup>-10</sup> Ω
Ra Table	89	R_a1	15	Cell1 R_a 7	I2	1	32767	578	2 <sup>-10</sup> Ω
Ra Table	89	R_a1	17	Cell1 R_a 8	I2	1	32767	563	2 <sup>-10</sup> Ω
Ra Table	89	R_a1	19	Cell1 R_a 9	I2	1	32767	544	2 <sup>-10</sup> Ω
Ra Table	89	R_a1	21	Cell1 R_a 10	I2	1	32767	574	2 <sup>-10</sup> Ω
Ra Table	89	R_a1	23	Cell1 R_a 11	I2	1	32767	726	2 <sup>-10</sup> Ω
Ra Table	89	R_a1	25	Cell1 R_a 12	I2	1	32767	956	2 <sup>-10</sup> Ω
Ra Table	89	R_a1	27	Cell1 R_a 13	I2	1	32767	1222	2 <sup>-10</sup> Ω
Ra Table	89	R_a1	29	Cell1 R_a 14	I2	1	32767	8099	2 <sup>-10</sup> Ω
Ra Table	90	R_a0x	0	xCell0 R_a flag	H1	0x00	0x255	0x55	-
Ra Table	90	R_a0x	1	xCell0 R_a 0	I2	1	32767	424	2 <sup>-10</sup> Ω
Ra Table	90	R_a0x	3	xCell0 R_a 1	I2	1	32767	509	2 <sup>-10</sup> Ω

**Table 4-7. Data Flash Summary (continued)**

Class	Subclass ID	Subclass	Offset	Name	Data Type	Min Value	Max Value	Default Value	Units (EVSW Units)*
Ra Table	90	R_a0x	5	xCell0 R_a 2	I2	1	32767	538	2 <sup>-10</sup> Ω
Ra Table	90	R_a0x	7	xCell0 R_a 3	I2	1	32767	535	2 <sup>-10</sup> Ω
Ra Table	90	R_a0x	9	xCell0 R_a 4	I2	1	32767	461	2 <sup>-10</sup> Ω
Ra Table	90	R_a0x	11	xCell0 R_a 5	I2	1	32767	460	2 <sup>-10</sup> Ω
Ra Table	90	R_a0x	13	xCell0 R_a 6	I2	1	32767	509	2 <sup>-10</sup> Ω
Ra Table	90	R_a0x	15	xCell0 R_a 7	I2	1	32767	578	2 <sup>-10</sup> Ω
Ra Table	90	R_a0x	17	xCell0 R_a 8	I2	1	32767	563	2 <sup>-10</sup> Ω
Ra Table	90	R_a0x	19	xCell0 R_a 9	I2	1	32767	544	2 <sup>-10</sup> Ω
Ra Table	90	R_a0x	21	xCell0 R_a 10	I2	1	32767	574	2 <sup>-10</sup> Ω
Ra Table	90	R_a0x	23	xCell0 R_a 11	I2	1	32767	726	2 <sup>-10</sup> Ω
Ra Table	90	R_a0x	25	xCell0 R_a 12	I2	1	32767	956	2 <sup>-10</sup> Ω
Ra Table	90	R_a0x	27	xCell0 R_a 13	I2	1	32767	1222	2 <sup>-10</sup> Ω
Ra Table	90	R_a0x	29	xCell0 R_a 14	I2	1	32767	8099	2 <sup>-10</sup> Ω
Ra Table	91	R_a1x	0	xCell1 R_a flag	H1	0x00	0x255	0x55	-
Ra Table	91	R_a1x	1	xCell1 R_a 0	I2	1	32767	424	2 <sup>-10</sup> Ω
Ra Table	91	R_a1x	3	xCell1 R_a 1	I2	1	32767	509	2 <sup>-10</sup> Ω
Ra Table	91	R_a1x	5	xCell1 R_a 2	I2	1	32767	538	2 <sup>-10</sup> Ω
Ra Table	91	R_a1x	7	xCell1 R_a 3	I2	1	32767	535	2 <sup>-10</sup> Ω
Ra Table	91	R_a1x	9	xCell1 R_a 4	I2	1	32767	461	2 <sup>-10</sup> Ω
Ra Table	91	R_a1x	11	xCell1 R_a 5	I2	1	32767	460	2 <sup>-10</sup> Ω
Ra Table	91	R_a1x	13	xCell1 R_a 6	I2	1	32767	509	2 <sup>-10</sup> Ω
Ra Table	91	R_a1x	15	xCell1 R_a 7	I2	1	32767	578	2 <sup>-10</sup> Ω
Ra Table	91	R_a1x	17	xCell1 R_a 8	I2	1	32767	563	2 <sup>-10</sup> Ω
Ra Table	91	R_a1x	19	xCell1 R_a 9	I2	1	32767	544	2 <sup>-10</sup> Ω
Ra Table	91	R_a1x	21	xCell1 R_a 10	I2	1	32767	574	2 <sup>-10</sup> Ω
Ra Table	91	R_a1x	23	xCell1 R_a 11	I2	1	32767	726	2 <sup>-10</sup> Ω
Ra Table	91	R_a1x	25	xCell1 R_a 12	I2	1	32767	956	2 <sup>-10</sup> Ω
Ra Table	91	R_a1x	27	xCell1 R_a 13	I2	1	32767	1222	2 <sup>-10</sup> Ω
Ra Table	91	R_a1x	29	xCell1 R_a 14	I2	1	32767	8099	2 <sup>-10</sup> Ω
Calibration	104	Data	2	Int Temp Offset	I1	-128	127	0	
Calibration	104	Data	3	Ext Temp Offset	I1	-128	127	0	
Calibration	104	Data	4	Pack V Offset	I1	-128	127	0	
Security	112	Codes	0	Sealed to Unsealed	H4	0x00000000	0xffffffff	0x00000000	-
Security	112	Codes	4	Unsealed to Full	H4	0x00000000	0xffffffff	0x00000000	-
Security	112	Codes	8	FactRestore Key	H4	0x00000000	0xffffffff	0x00000000	-

## 5 FUNCTIONAL DESCRIPTION

### 5.1 FUEL GAUGING

The bq27620-G1 measures cell voltage and temperature to determine battery SOC. Current is not directly measured but is estimated by the Impedance Track™ with Dynamic Voltage Correlation (DVC) algorithm. When an application load is applied, the impedance of the cell is measured by comparing the OCV obtained from a predefined function for present SOC with the measured voltage under load. Measurements of OCV and battery impedance determine chemical state of charge. The bq27620-G1 acquires and updates the battery-impedance profile during normal battery usage to determine *FullChargeCapacity()* and *StateOfCharge()*, specifically for the present load and temperature. *FullChargeCapacity()* is reported as capacity available from a fully charged battery under the present load and temperature until *Voltage()* reaches the **Terminate Voltage**. *NominalAvailableCapacity()* and *FullAvailableCapacity()* are the uncompensated (no or light load) versions of *RemainingCapacity()* and *FullChargeCapacity()* respectively.

The bq27620-G1 has two flags accessed by the *Flags()* function that warns when the battery's SOC has fallen to critical levels. When *RemainingCapacity()* falls below the first capacity threshold, specified in **SOC1 Set Threshold**, the *[SOC1]* (*State of Charge Initial*) flag is set. The flag is cleared once *RemainingCapacity()* rises above SOC1 Set Threshold. All units are in mAh.

When *Voltage()* falls below the system shut down threshold voltage, **SysDown Set Volt Threshold**, the *[SYSDOWN]* flag is set, serving as a final warning to shut down the system. The SOC\_INT also signals. When *Voltage()* rises above **SysDown Clear Voltage** and the *[SYSDOWN]* flag has already been set, the *[SYSDOWN]* flag is cleared. The SOC\_INT also signals such change. All units are in mV.

## 5.2 IMPEDANCE TRACK™ VARIABLES

The bq27620-G1 has several data flash variables that permit the user to customize the Impedance Track™ algorithm for optimized performance. These variables are dependent upon the power characteristics of the application as well as the cell itself.

### 5.2.1 Load Mode

*Load Mode* is used to select either the constant-current or constant-power model for the Impedance Track™ algorithm as used in **Load Select** (see **Load Select**). When **Load Mode** is 0, the *Constant Current Model* is used (default). When 1, the *Constant Power Model* is used. The [LDMD] bit of CONTROL\_STATUS reflects the status of **Load Mode**.

### 5.2.2 Load Select

**Load Select** defines the type of power or current model to be used to compute load-compensated capacity in the Impedance Track™ algorithm. If **Load Mode** = 0 (*Constant-Current*) then the options presented in [Table 5-1](#) are available.

**Table 5-1. Constant-Current Model Used When Load Mode = 0**

LoadSelect Value	Current Model Used
0	Average discharge current from previous cycle: There is an internal register that records the average discharge current through each entire discharge cycle. The previous average is stored in this register.
1(default)	Present average discharge current: This is the average discharge current from the beginning of this discharge cycle until present time.
2	Average current: based on <b>EffectiveCurrent()</b>
3	Current: based off of a low-pass-filtered version of <b>EffectiveCurrent()</b> ( $\tau = 14$ s)
4	Design capacity / 5: C Rate based off of Design Capacity /5 or a C/5 rate in mA.
5	AtRate (mA): Use whatever current is in <b>AtRate()</b>
6	User_Rate-mA: Use the value in <i>User_Rate-mA</i> . This mode provides a completely user-configurable method.

If **Load Mode** = 1 (*Constant Power*) then the following options shown in [Table 5-2](#) are available

**Table 5-2. Constant-Power Model Used When Load Mode = 1**

LoadSelect Value	Power Model Used
0	Average discharge power from previous cycle: There is an internal register that records the average discharge power through each entire discharge cycle. The previous average is stored in this register.
1(default)	Present average discharge power: This is the average discharge power from the beginning of this discharge cycle until present time.
2	Average current x voltage: based off the <b>EffectiveCurrent()</b> and <b>Voltage()</b> .
3	Current x voltage: based off of a low-pass-filtered version of <b>EffectiveCurrent()</b> ( $\tau = 14$ s) and <b>Voltage()</b>
4	Design energy / 5: C Rate based off of Design Energy /5 or a C/5 rate in mA.
5	AtRate (10 mW): Use whatever value is in <b>AtRate()</b> .
6	User_Rate-10mW: Use the value in <i>User_Rate-10mW</i> . This mode provides a completely user-configurable method.

### 5.2.3 Reserve Cap-mAh

**Reserve Cap-mAh** determines how much actual remaining capacity exists after reaching 0 **RemainingCapacity()**, before **Terminate Voltage** is reached. A no-load rate of compensation is applied to this reserve.

### 5.2.4 Reserve Cap-mWh

**Reserve Cap-mWh** determines how much actual remaining capacity exists after reaching 0 **AvailableEnergy()**, before **Terminate Voltage** is reached. A no-load rate of compensation is applied to this reserve capacity.

### 5.2.5 *Dsg Current Threshold Rate*

This register is used as a threshold by many functions in the bq27620-G1 to determine if actual discharge current is flowing into or out of the cell. The default for this register is in [Section 4.6](#), which should be sufficient for most applications. This threshold should be set low enough to be below any normal application load current but high enough to prevent noise or drift from affecting the measurement.

### 5.2.6 *Chg Current Threshold Rate*

This register is used as a threshold by many functions in the bq27620-G1 to determine if actual charge current is flowing into or out of the cell. The default for this register is in [Section 4.6](#), which should be sufficient for most applications. This threshold should be set low enough to be below any normal charge current but high enough to prevent noise or drift from affecting the measurement.

### 5.2.7 *Quit Current, DSG Relax Time, CHG Relax Time, and Quit Relax Time*

The **Quit Current** is used as part of the Impedance Track™ algorithm to determine when the bq27620-G1 enters relaxation mode from a current-flowing mode in either the charge direction or the discharge direction. The value of *Quit Current* is set to a default value in [Section 4.6](#) and should be above the standby current of the system.

Either of the following criteria must be met to enter relaxation mode:

- $|EffectiveCurrent()| < |Quit\ Current|$  for **Dsg Relax Time**
- $|EffectiveCurrent()| < |Quit\ Current|$  for **Chg Relax Time**

After about 5 minutes in relaxation mode, the bq27620-G1 attempts to take accurate OCV readings. An additional requirement of  $dV/dt < 1\ \mu V/s$  is required for the bq27620-G1 to perform optimization cycle. These updates are used in the Impedance Track™ algorithms. It is critical that the battery voltage be relaxed during OCV readings to and that the current is not be higher than C/20 when attempting to go into relaxation mode.

**Quit Relax Time** specifies the minimum time required for *EffectiveCurrent()* to remain above the **QuitCurrent** threshold before exiting relaxation mode.

### 5.2.8 *Delta Voltage*

The bq27620-G1 stores the maximum difference of *Voltage()* during short load spikes and normal load, so the Impedance Track™ algorithm can calculate remaining capacity for pulsed loads. It is not recommended to change this value.

### 5.2.9 *Default Ra and Ra Tables*

These tables contain encoded data and, with the exception of the **Default Ra Tables**, are automatically updated during device operation. Arbitrations happen on pack insert and based on a Ra measurement. No user changes should be made except for reading/writing the values from a pre-learned pack (part of the process for creating golden image files).

## 5.3 DETAILED PIN DESCRIPTION

### 5.3.1 The Operation Configuration Register

Some bq27620-G1 pins are configured via the **Operation Configuration** data flash register, as indicated in [Table 5-3](#). This register is programmed/read via the methods described in [Section 4.2.1](#), Accessing the Data Flash. The register is located at subclass = 64, offset = 0.

**Table 5-3. Operation Configuration Bit Definition**

	bit7	bit6	bit5	bit4	bit3	bit2	bit1	bit0
<b>High Byte</b>	RESCAP	BATG_OVR	INT_BREM	PFC1	PFC2	–	–	–
<b>Default =</b>	0	0	0	0	1	0	0	0
<b>0x08</b>								
<b>Low Byte</b>	INT_FOCV	IDSELEN	LDODEOC	RMFCC	SOCPOL	BATGPOL	BATLPOL	TEMPS
<b>Default =</b>	0	1	1	1	0	0	1	1
<b>0x73</b>								

RESCAP = No-load rate of compensation is applied to the reserve capacity calculation. True when set.

BATG\_OVR = BAT\_GD override bit. If the gauge enters Hibernate only due to the cell voltage, the BAT\_GD pin will not negate. True when set.

INT\_BREM = Battery removal interrupt bit. The SOC\_INT pulses 1ms when the battery removal interrupt is enabled. True when set.

PFC1/PFC2 = Pin function code (PFC) mode selection: PFC 0, 1, or 2 selected by 0/0, 0/1, or 1/0, respectively.

INT\_FOCV = Indication of the measurement of the OCV during the initialization. The SOC\_INT will pulse during the first measurement if this bit is set. True when set.

IDSELEN = Enables cell profile selection feature. True when set.

LDODEOC = Learned DoD at EOC is the recording of DoD at EOC when set. If cleared the bq27620 records the the V\_charger voltage and uses it to dynamically compute DoD at EOC based on the current temperature. True when set.

RMFCC = RM is updated with the value from FCC, on valid charge termination. True when set.

SOCPOL = SOC interrupt polarity is active-low. True when cleared.

BATGPOL = BAT\_GD pin is active-low. True when cleared.

BATLPOL = BAT\_LOW pin is active-high. True when set.

TEMPS = Selects external thermistor for *Temperature()* measurements. True when set.

Some bq27620-G1 pins are configured via the **Operation Configuration B** data flash register, as indicated in [Table 5-4](#). This register is programmed/read via the methods described in Section 4.2.1: Accessing the Data Flash. The register is located at subclass = 64, offset = 9.

**Table 5-4. Operation Configuration B Bit Definition**

	bit7	bit6	bit5	bit4	bit3	bit2	bit1	bit0
<b>Byte</b>	WRTEMP	BIE	BL_INT	GNDSEL	FCE	DFWrIndBL	RFACTSTEP	INDFACRES
<b>Default=</b>	0	1	0	0	1	0	1	1
<b>0x4B</b>								

WRTEMP = Enables the temperature write. The temperature could be written by the host. True when set.

BIE = Battery insertion detection enable. When the battery insertion detection is disabled, the gauge relies on the host command to set the BAT\_DET bit. True when set.

BL\_INT = Battery low interrupt enable. True when set.

GNDSEL = The ADC ground select control. The Vss (Pin D1) is selected as ground reference when the bit is clear. Pin A1 is selected when the bit is set.

FCE = The Fast Convergence Enabled.

DFWrIndBL = DataFlash Write Indication. SOC\_INT is used for indication if the bit is clear. BAT\_LOW is used for indication if the bit is set.

RFACTSTEP = Enables Ra Step up/down to Min/Max Res Factor before disabling Ra updates.

INDFACRES = Although the default is '1', the function associated with this bit has been removed from firmware.

**Table 5-5. Operation Configuration C Bit Definition**

	bit7	bit6	bit5	bit4	bit3	bit2	bit1	bit0
<b>Byte</b>	BATGSPUEN	BATGWPUEN	BATLSPUEN	BATLWPUEN	VCCE	–	DeltaVOpt1	DeltaVOpt0
<b>Default =</b>	0	0	1	0	1	0	0	0
<b>0x28</b>								

BATGSPUEN = BAT\_GD pin strong pull-up enable.

BATGWPUEN = BAT\_GD pin weak pull-up enable.

BATLSPUEN = BAT\_LOW pin strong pull-up enable.

BATLWPUEN = BAT\_LOW pin weak pull-up enable.

VCCE = Voltage Consistency Check Enable.

DeltaVOpt[1:0] = Configures options for determination of **Delta Voltage** which is defined as the maximum difference in *Voltage( )* during normal load and short load spikes. **Delta Voltage** is used as a compensation factor for calculating for *RemainingCapacity( )* under pulsed loads.

0/0 = Standard DeltaV. Average variance from steady state voltage used to determine end of discharge voltage. (Default)

0/1 = No Averaging. The last instantaneous change in *Voltage( )* from steady state is used to determine the end of discharge voltage.

1/0 = Use the value in **Min Delta Voltage**.

1/1 = Not used.

### 5.3.2 Pin Function Code Descriptions

This fuel gauge has several pin-function configurations available for the end application. Each configuration is assigned a pin function code, or PFC, specified by **Op Config [PFC\_CFG1, PFC\_CFG0]**. (see [Table 5-6](#) below.) If the fuel gauge is configured to measure external temperature via **Op Config [TEMPS]**, a voltage bias of approximately 125 mSec will be applied periodically to the external thermistor network in order to make a temperature measurement.

**Table 5-6. Pin Function Code Summary**

PFC	PFC_CFG [1:0]	External Thermistor Bias Rate ( <i>TEMP</i> =1 only)			BAT_GD pin Usage for PFC	Pin Function Description
		Dis-charge	Charge	Sleep		
0	0/0	1 / sec	1 / sec	1 / 20 sec	N/A	A dedicated external thermistor is used for the fuel gauge to monitor battery temperature in all conditions. The BAT_GD pin is not used to interface with a charger IC.
1	0/1				Temperature-based Charge Inhibit.	A dedicated external thermistor is used for the fuel gauge to monitor battery temperature in all conditions. If battery charging temperature falls outside of the preset range defined in data flash, a charger can be disabled via the BAT_GD pin until cell temperature recovers. See <i>Charge Inhibit and Suspend</i> , for additional details.
2	1/0				None	A shared external thermistor is supported between the fuel gauge and a charger IC; however, the BAT_GD pin is not used to interface with the charger IC. The fuel gauge will bias the thermistor for battery temperature measurement and BAT_INSERT CHECK mode (If <i>OpConfig B [BIE]</i> = 1) under discharge and relaxation conditions only so the charger IC can separately bias the thermistor during charge mode.
3	1/1				1 / sec	Follows <i>Flags( ) [FC]</i> flags bit.

### 5.3.3 BAT\_LOW Pin

The BAT\_LOW pin provides a system processor with an electrical indicator of battery status. The signaling on the BAT\_LOW pin follows the status of the *[SOC1]* bit in the *Flags( )* register. Note that the polarity of the BAT\_LOW pin can be inverted via the *[BATL\_POL]* bit of **Operation Configuration**.

### 5.3.4 Power Path Control With the BAT\_GD Pin

The bq27620-G1 must operate in conjunction with other electronics in a system appliance, such as chargers or other ICs and application circuits that draw appreciable power. After a battery is inserted into the system, there should be no charging current or a discharging current higher than C/20, so that an accurate OCV can be read. The OCV is used for helping determine which battery profile to use, as it constitutes part of the battery impedance measurement.

When a battery is inserted into a system, the Impedance Track™ algorithm requires that no charging of the battery takes place and that any discharge is limited to less than C/20—these conditions are sufficient for the fuel gauge to take an accurate OCV reading. To disable these functions, the BAT\_GD pin is merely negated from the default setting. Once an OCV reading has been made, the BAT\_GD pin is asserted, thereby enabling battery charging and regular discharge of the battery. The **Operation Configuration [BATG\_POL]** bit can be used to set the polarity of the battery good signal, should the default configuration need to be changed.

[Figure 5-1](#) details how the BAT\_GD pin functions in the context of battery insertion and removal, as well as NORMAL vs. SLEEP modes.

In PFC 1, the BAT\_GD pin is also used to disable battery charging when the bq27620-G1 reads battery temperatures outside the range defined by **[Charge Inhibit Temp Low, Charge Inhibit Temp High]**. The BAT\_GD line is asserted once temperature falls within the range **[Charge Inhibit Temp Low + Temp Hys, Charge Inhibit Temp High – Temp Hys]**.

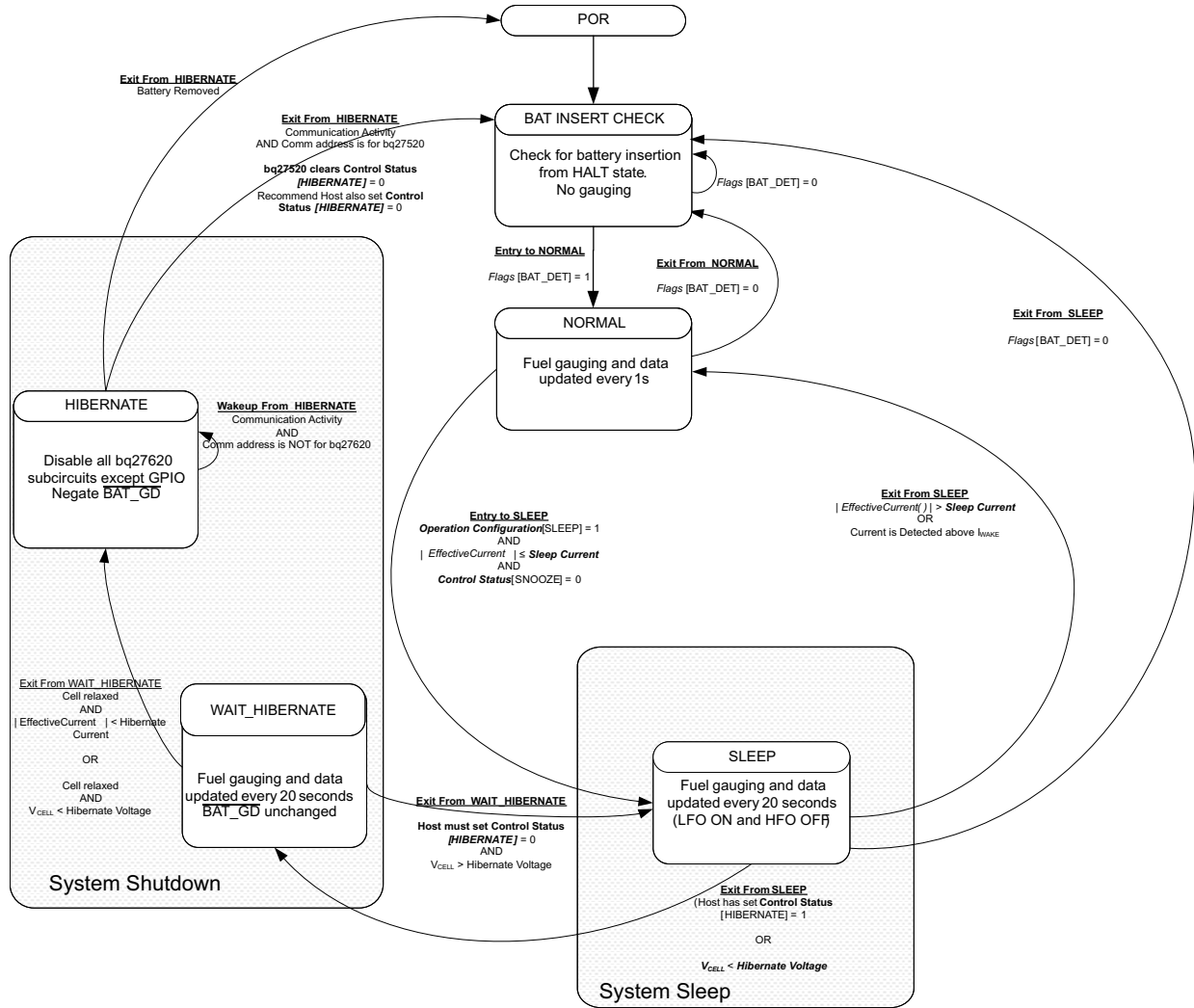

Figure 5-1. Power Mode Diagram

### 5.3.5 Battery Detection Using the BI/TOUT Pin

During power-up or hibernate activities, or any other activity where the bq27620-G1 needs to determine whether a battery is connected or not, the fuel gauge applies a test for battery presence. First, the BI/TOUT pin is put into high-Z status. The weak 1.8MΩ pull-up resistor will keep the pin high while no battery is present. When a battery is inserted (or is already inserted) into the system device, the BI/TOUT pin will be pulled low. This state is detected by the fuel gauge, which polls this pin every second when the gauge has power. A *battery-disconnected* status is assumed when the bq27620-G1 reads a thermistor voltage that is near 2.5V.

### 5.3.6 SOC\_INT pin

The SOC\_INT pin generates a pulse of different pulse widths under various conditions as indicated by the table below. After initialization only one SOC\_INT pulse will be generated within any given one second time slot and therefore, may indicate multiple event conditions.

**Table 5-7. SOC\_INT Pulse Condition and Width**

	Enable Condition	Pulse Width	Comment
SOC_Delta Point	SOC_Delta $\neq$ 0	1 ms	During charge, when the SOC is greater than ( $>$ ) the points, $100\% - n \times \text{SOC\_Delta}$ and $100\%$ ; During discharge, when the SOC reaches ( $\leq$ ) the points $100\% - n \times \text{SOC\_Delta}$ and $0\%$ ; where n is an integer starting from 0 to the number generating SOC no less than $0\%$
SOC1 Set	Always	1 ms	When RSOC reached the SOC1 Set or Clear threshold set in the Data Flash and BL_INT bit in <b>Operation Configuration B</b> is set.
SOC1 Clear	Always	1 ms	
SysDown Set	Always	1 ms	When the Battery Voltage reached the SysDown Set or Clear threshold set in the Data Flash
SysDown Clear	Always	1 ms	
State Change	SOC_Delta $\neq$ 0	1 ms	When there is a state change including charging, discharging and relaxation. This function is disabled when SOC_Delta is set to 0.
Battery Removal	INT_BREM bit is set in OpConfig AND BIE bit is set	1 ms	This function is disabled when BIE is cleared.
OCV Command	After Initialization	About 165ms. Same as the OCV command execution time period	SOC_INT pulses for the OCV command after the initialization.
OCV Command	INT_FOCV bit is set in OpConfig	About 165ms. Same as the OCV command execution time period	This command is to generate the SOC_INT pulse during the initialization.
Data Flash Write	After Initialization AND DFWrIndWaitTime $\neq$ 0	Programmable pulse width flash (see comment)	SOC_INT is used to indicate the data flash update. The gauge will wait <b>DFWrIndWaitTime</b> times $5\mu\text{s}$ after the SOC_INT signal to start the data flash update. This function is disabled if DFWrIndWaitTime is set to 0.
OTC or OTD Flags	Always	1 ms	Upon first assertion of Flags[OTC] or Flags[OTD] over temperature conditions.

## 5.4 TEMPERATURE MEASUREMENT

The bq27620-G1 measures battery temperature via its TS input, in order to supply battery temperature status information to the fuel gauging algorithm and charger-control sections of the gauge. Alternatively, it can also measure internal temperature via its on-chip temperature sensor, but only if the **[TEMPS]** bit of the **Operation Configuration** register is cleared. The **[GNDSEL]** bit of Operation Configuration B register selects the ground reference of the ADC converter for temperature measurement.

Regardless of which sensor is used for measurement, a system processor can request the current battery temperature by calling the *Temperature()* function (see [Section 4.1.1, Standard Data Commands](#), for specific information).

The thermistor circuit requires the use of an external NTC 103AT-type thermistor. Additional circuit information for connecting this thermistor to the bq27620-G1 is shown in [Section 8, Reference Schematic](#).

## 5.5 OVERTEMPERATURE INDICATION

### 5.5.1 Overtemperature: Charge

If during charging, *Temperature()* reaches the threshold of **OT Chg** for a period of **OT Chg Time** and *EffectiveCurrent()* > **Chg Current Threshold**, then the **[OTC]** bit of *Flags()* is set. When *Temperature()* falls to **OT Chg Recovery**, the **[OTC]** of *Flags()* is reset.

If **OT Chg Time** = 0, then the feature is completely disabled.

### 5.5.2 Overtemperature: Discharge

If during discharging, *Temperature()* reaches the threshold of **OT Dsg** for a period of **OT Dsg Time**, and *EffectiveCurrent()* ≤ **-Dsg Current Threshold**, then the **[OTD]** bit of *Flags()* is set. When *Temperature()* falls to **OT Dsg Recovery**, the **[OTD]** bit of *Flags()* is reset.

If **OT Dsg Time** = 0, then feature is completely disabled.

## 5.6 CHARGING AND CHARGE-TERMINATION INDICATION

### 5.6.1 Detecting Charge Termination

For proper bq27620-G1 operation, the cell charging voltage must be specified by the user. The default value for this variable is **Charging Voltage** [Section 4.6](#).

The bq27620-G1 detects charge termination when (1) during 2 consecutive periods of **Current Taper Window**, the *EffectiveCurrent()* is < **Taper Current**, (2) during the same periods, the accumulated change in capacity > Min Taper Charge / **Current Taper Window**, and (3) *Voltage()* > **Charging Voltage – Taper Voltage**. When this occurs, the **[CHG]** bit of *Flags()* is cleared. Also, if the **[RMFCC]** bit of **Operation Configuration** is set, then *RemainingCapacity()* is set equal to *FullChargeCapacity()*.

### 5.6.2 Charge Inhibit and Suspend

The bq27620-G1 can indicate when battery temperature has fallen below or risen above predefined thresholds **Charge Inhibit Temp Low** or **Charge Inhibit Temp High**, respectively. In this mode, the **[CHG\_INT]** bit is set and the  $\overline{\text{BAT\_GD}}$  pin is deserted to indicate this condition. The **[CHG\_INT]** bit is cleared and the  $\overline{\text{BAT\_GD}}$  pin is asserted once the battery temperature returns to the range **[Charge Inhibit Temp Low + Temp Hys, Charge Inhibit Temp High – Temp Hys]**.

When **PFC** = 1, the bq27620-G1 can indicate when battery temperature has fallen below or risen above predefined thresholds **Suspend Low Temp** or **Suspend High Temp**, respectively. In this mode, the **[XCHG]** bit is set to indicate this condition. The **[XCHG]** bit is cleared once the battery temperature returns to the range **[Charge Inhibit Temp Low + Temp Hys, Charge Inhibit Temp High – Temp Hys]**.

The charging should not start when the temperature is below the Charge Inhibit Temp Low or above the Charge Inhibit Temp High. The charging can continue if the charging starts inside the window [Charge Inhibit Temp Low, Charge Inhibit Temp High] until the temperature is either below Suspend Low Temp or above the Suspend Low Temp. Therefore, the window [Charge Inhibit Temp Low, Charge Inhibit Temp High] must be inside the window of [Suspend Low Temp, Suspend High Temp].

## 5.7 POWER MODES

The bq27620-G1 has different power modes: BAT INSERT CHECK, NORMAL and HIBERNATE. In NORMAL mode, the bq27620-G1 is fully powered and can execute any allowable task. In HIBERNATE mode, the fuel gauge is in a low power state, but can be woken up by communication or certain I/O activity. Finally, the BAT INSERT CHECK mode is a powered-up, but low-power halted, state, where the bq27620-G1 resides when no battery is inserted into the system.

The relationship between these modes is shown in [Figure 5-1](#).

### 5.7.1 BAT INSERT CHECK Mode

This mode is a halted-CPU state that occurs when an adapter, or other power source, is present to power the bq27620-G1 (and system), yet no battery has been detected. When battery insertion is detected, a series of initialization activities begin, which include: OCV measurement, setting the `BAT_GD` pin, and selecting the appropriate battery profiles.

Some commands, issued by a system processor, can be processed while the bq27620-G1 is halted in this mode. The gauge will wake up to process the command, then return to the halted state awaiting battery insertion.

### 5.7.2 NORMAL MODE

The fuel gauge is in NORMAL mode when not in any other power mode. During this mode, *EffectiveCurrent()*, *Voltage()* and *Temperature()* measurements are taken, and the interface data set is updated. Decisions to change states are also made. This mode is exited by activating a different power mode.

Because the gauge consumes the most power in NORMAL mode, the Impedance Track™ algorithm minimizes the time the fuel gauge remains in this mode.

### 5.7.3 HIBERNATE MODE

HIBERNATE mode should be used when the system equipment needs to enter a low-power state, and minimal gauge power consumption is required. This mode is ideal when a system equipment is set to its own HIBERNATE, SHUTDOWN, or OFF modes.

Before the fuel gauge can enter HIBERNATE mode, the system must set the `[HIBERNATE]` bit of the `CONTROL_STATUS` register. The gauge waits to enter HIBERNATE mode until it has taken a valid OCV measurement and the magnitude of the average cell current has fallen below **Hibernate Current**. The gauge can also enter HIBERNATE mode if the cell voltage falls below **Hibernate Voltage**. The gauge will remain in HIBERNATE mode until the system issues a direct I<sup>2</sup>C command to the gauge or a POR occurs. I<sup>2</sup>C Communication that is not directed to the gauge will not wake the gauge.

It is important that `BAT_GD` be de-asserted status (no battery charging/discharging). This prevents a charger application from inadvertently charging the battery before an OCV reading can be taken. It is the system's responsibility to wake the bq27620-G1 after it has gone into HIBERNATE mode. After waking, the gauge can proceed with the initialization of the battery information (OCV, profile selection, etc.)

## 6 APPLICATION-SPECIFIC INFORMATION

### 6.1 BATTERY PROFILE STORAGE AND SELECTION

#### 6.1.1 Common Profile Aspects

The bq27620-G1 maintains two chemistry profiles, PACK0 and PACK1. These profiles hold dynamic battery data, and keep track of the status for up to two of the most recent batteries used. When a battery pack is removed from host equipment, the bq27620-G1 selects the battery information when the battery is re-inserted. This way, Impedance Track™ algorithm has a means of recovering battery-status information, thereby maintaining good state-of-charge (SOC) estimates.

The bq27620-G1 can manage the information on two removable battery packs. In addition, the gauge has two default battery profiles available to store battery information. The profiles are used to provide the Impedance Track™ algorithm with the default information on two possible battery types expected to be used with the end-equipment. If a new pack is inserted that replaces an older worn out pack, the gauge automatically selects from one of the default profiles and writes that data into the oldest of the PACK0 or PACK1 profile.

#### 6.1.2 Activities Upon Pack Insertion

##### 6.1.2.1 First OCV and Impedance Measurement

At power-up the BAT\_GD pin is inactive, so that the system might not obtain power from the battery (this depends on actual implementation). In this state, the battery should be put in a condition with load current less than  $C/20$ . Next, the bq27620-G1 measures its first open-circuit voltage (OCV) via the BAT pin. The *[OCVCMDCOMP]* bit will set once the OCV measurement is completed. Depending on the load current, the *[OCVFAIL]* bit indicates whether the OCV reading is valid. From the OCV(SOC) table, the SOC of the inserted battery is found. Then the BAT\_GD pin is made active, and the impedance of the inserted battery is calculated from the measured voltage and the load current:  $Z(\text{SOC}) = (\text{OCV}(\text{SOC}) - V) / I$ . This impedance is compared with the impedance of the dynamic profiles, *Packn*, and the default profiles, *Defn*, for the same SOC (the letter *n* depicts either a **0** or **1**). The *[INITCOMP]* bit will be set afterwards and the OCV command could be issued

##### 6.1.3 Reading HostCfg

The *HostCfg* data flash location contains cell profile status information, and can be read using the *ApplicationStatus()* extended command (0x6a). The bit configuration of this function/location is shown in [Table 6-1](#).

**Table 6-1. HostCfg Bit Definitions.**

HostCfg	bit7	bit6	bit5	bit4	bit3	bit2	bit1	bit0
Byte	—	—	—	—	OPTCMP	—	—	LU_PROF

LU\_PROF = Last profile used by fuel gauge. *Cell0* last used when cleared. *Cell1* last used when set. Default is 0.

OPTCMP = OPTMIZ bit is set. Default is 0.

## 7 COMMUNICATIONS

### 7.1 I<sup>2</sup>C INTERFACE

The bq27620-G1 supports the standard I<sup>2</sup>C read, incremental read, quick read, one byte write, and incremental write functions. The 7 bit device address (ADDR) is the most significant 7 bits of the hex address and is fixed as 1010101. The first 8-bits of the I<sup>2</sup>C protocol will; therefore, be 0xAA or 0xAB for write or read, respectively.

 Host generated     Gauge generated

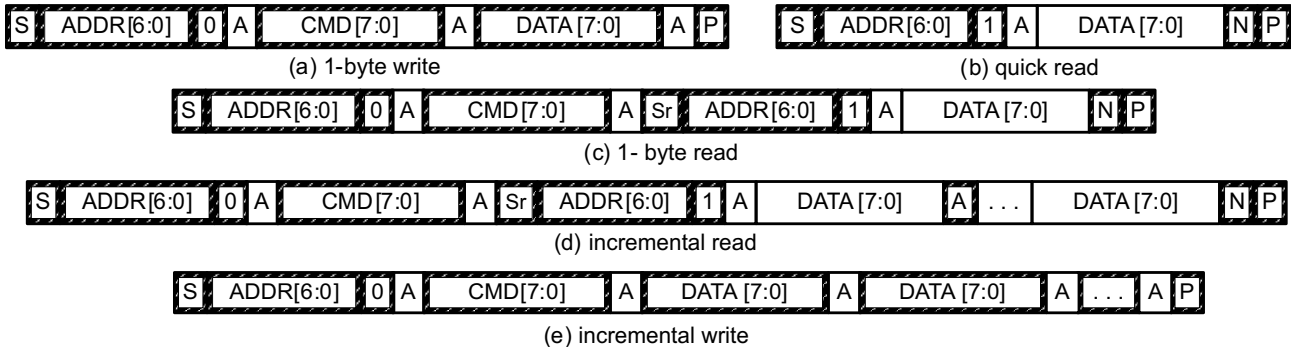

(S = Start, Sr = Repeated Start, A = Acknowledge, N = No Acknowledge, and P = Stop).

The “quick read” returns data at the address indicated by the address pointer. The address pointer, a register internal to the I<sup>2</sup>C communication engine, will increment whenever data is acknowledged by the bq27620-G1 or the I<sup>2</sup>C master. “Quick writes” function in the same manner and are a convenient means of sending multiple bytes to consecutive command locations (such as two-byte commands that require two bytes of data)

The following command sequences are not supported:

Attempt to write a read-only address (NACK after data sent by master):

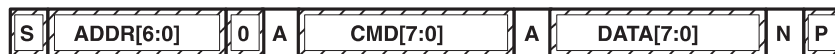

Attempt to read an address above 0x6B (NACK command):



### 7.2 I<sup>2</sup>C Time Out

The I<sup>2</sup>C engine will release both SDA and SCL if the I<sup>2</sup>C bus is held low for 2 seconds. If the bq27620-G1 was holding the lines, releasing them will free them for the master to drive the lines. If an external condition is holding either of the lines low, the I<sup>2</sup>C engine will enter the low power sleep mode.

### 7.3 I<sup>2</sup>C Command Waiting Time

To ensure proper operation at 400 kHz, a  $t_{(BUF)} \geq 66 \mu s$  bus free waiting time should be inserted between all packets addressed to the bq27620-G1 . In addition, if the SCL clock frequency ( $f_{SCL}$ ) is  $> 100 \text{ kHz}$ , use individual 1-byte write commands for proper data flow control. The following diagram shows the standard waiting time required between issuing the control subcommand the reading the status result. For read-write standard command, a minimum of 2 seconds is required to get the result updated. For read-only standard commands, there is no waiting time required, but the host should not issue all standard commands more than two times per second. Otherwise, the gauge could result in a reset issue due to the expiration of the watchdog timer.

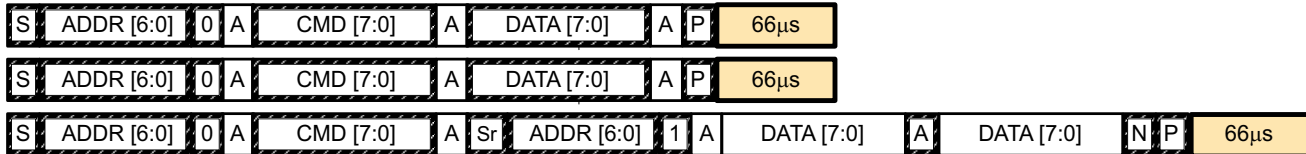

Waiting time inserted between two 1-byte write packets for a subcommand and reading results (required for  $100 \text{ kHz} < f_{SCL} \leq 400 \text{ kHz}$ )

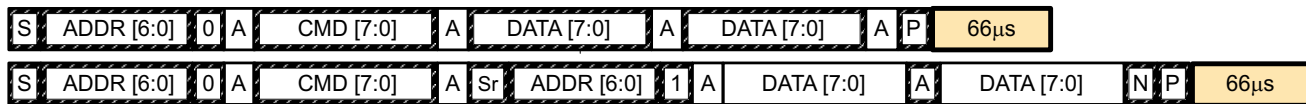

Waiting time inserted between incremental 2-byte write packet for a subcommand and reading results (acceptable for  $f_{SCL} \leq 100 \text{ kHz}$ )



Waiting time inserted after incremental read

### 7.4 I<sup>2</sup>C Clock Stretching

A clock stretch can occur during all modes of fuel gauge operation. In SLEEP and HIBERNATE modes, a short clock stretch will occur on all I<sup>2</sup>C traffic as the device must wake-up to process the packet. In the other modes ( BAT INSERT CHECK , NORMAL) clock stretching will only occur for packets addressed for the fuel gauge. The majority of clock stretch periods are small as the I<sup>2</sup>C interface performs normal data flow control. However, less frequent yet more significant clock stretch periods may occur as blocks of Data Flash are updated. The following table summarizes the approximate clock stretch duration for various fuel gauge operating conditions.

Gauging Mode	Operating Condition / Comment	Approximate Duration
SLEEP HIBERNATE	Clock stretch occurs at the beginning of all traffic as the device wakes up.	$\leq 4 \text{ ms}$
BAT INSERT CHECK NORMAL	Clock stretch occurs within the packet for flow control. (after a start bit, ACK or first data bit)	$\leq 4 \text{ ms}$
	Normal Ra table Data Flash updates.	24 ms
	Data Flash block writes.	72 ms
	Restored Data Flash block write after loss of power.	116 ms
	End of discharge Ra table Data Flash update.	144 ms

## 8 REFERENCE SCHEMATICS

### 8.1 SCHEMATIC

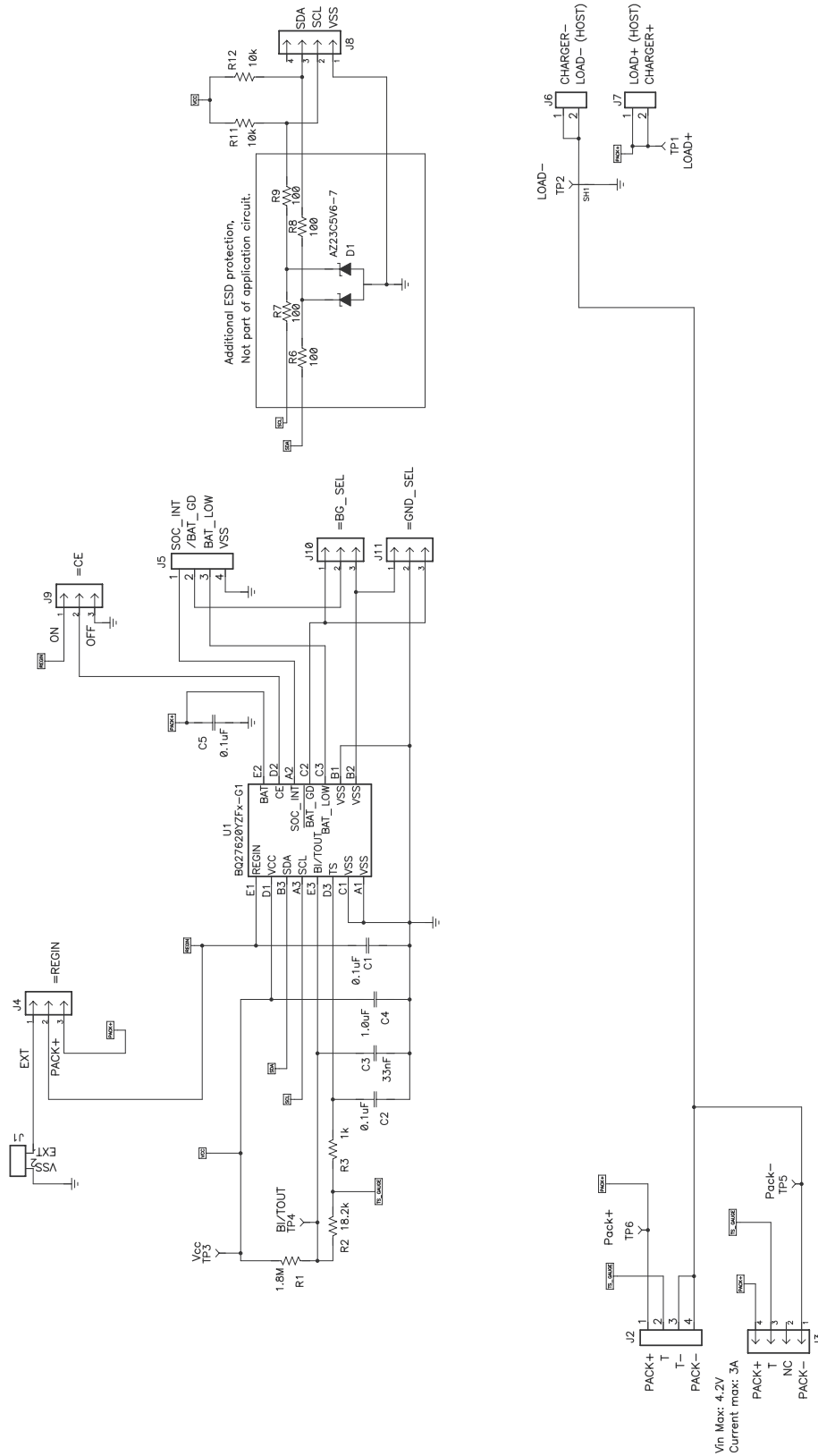

**PACKAGING INFORMATION**

Orderable Device	Status (1)	Package Type	Package Drawing	Pins	Package Qty	Eco Plan (2)	Lead/Ball Finish (6)	MSL Peak Temp (3)	Op Temp (°C)	Device Marking (4/5)	Samples
BQ27620YZFR-G1	NRND	DSBGA	YZF	15	3000	Green (RoHS & no Sb/Br)	SNAGCU	Level-1-260C-UNLIM	-40 to 85	BQ27620G	
BQ27620YZFT-G1	NRND	DSBGA	YZF	15	250	Green (RoHS & no Sb/Br)	SNAGCU	Level-1-260C-UNLIM	-40 to 85	BQ27620G	

(1) The marketing status values are defined as follows:

**ACTIVE:** Product device recommended for new designs.

**LIFEBUY:** TI has announced that the device will be discontinued, and a lifetime-buy period is in effect.

**NRND:** Not recommended for new designs. Device is in production to support existing customers, but TI does not recommend using this part in a new design.

**PREVIEW:** Device has been announced but is not in production. Samples may or may not be available.

**OBSELETE:** TI has discontinued the production of the device.

(2) Eco Plan - The planned eco-friendly classification: Pb-Free (RoHS), Pb-Free (RoHS Exempt), or Green (RoHS & no Sb/Br) - please check <http://www.ti.com/productcontent> for the latest availability information and additional product content details.

**TBD:** The Pb-Free/Green conversion plan has not been defined.

**Pb-Free (RoHS):** TI's terms "Lead-Free" or "Pb-Free" mean semiconductor products that are compatible with the current RoHS requirements for all 6 substances, including the requirement that lead not exceed 0.1% by weight in homogeneous materials. Where designed to be soldered at high temperatures, TI Pb-Free products are suitable for use in specified lead-free processes.

**Pb-Free (RoHS Exempt):** This component has a RoHS exemption for either 1) lead-based flip-chip solder bumps used between the die and package, or 2) lead-based die adhesive used between the die and leadframe. The component is otherwise considered Pb-Free (RoHS compatible) as defined above.

**Green (RoHS & no Sb/Br):** TI defines "Green" to mean Pb-Free (RoHS compatible), and free of Bromine (Br) and Antimony (Sb) based flame retardants (Br or Sb do not exceed 0.1% by weight in homogeneous material)

(3) MSL, Peak Temp. - The Moisture Sensitivity Level rating according to the JEDEC industry standard classifications, and peak solder temperature.

(4) There may be additional marking, which relates to the logo, the lot trace code information, or the environmental category on the device.

(5) Multiple Device Markings will be inside parentheses. Only one Device Marking contained in parentheses and separated by a "~" will appear on a device. If a line is indented then it is a continuation of the previous line and the two combined represent the entire Device Marking for that device.

(6) Lead/Ball Finish - Orderable Devices may have multiple material finish options. Finish options are separated by a vertical ruled line. Lead/Ball Finish values may wrap to two lines if the finish value exceeds the maximum column width.

**Important Information and Disclaimer:** The information provided on this page represents TI's knowledge and belief as of the date that it is provided. TI bases its knowledge and belief on information provided by third parties, and makes no representation or warranty as to the accuracy of such information. Efforts are underway to better integrate information from third parties. TI has taken and continues to take reasonable steps to provide representative and accurate information but may not have conducted destructive testing or chemical analysis on incoming materials and chemicals. TI and TI suppliers consider certain information to be proprietary, and thus CAS numbers and other limited information may not be available for release.

In no event shall TI's liability arising out of such information exceed the total purchase price of the TI part(s) at issue in this document sold by TI to Customer on an annual basis.

## TAPE AND REEL INFORMATION



### QUADRANT ASSIGNMENTS FOR PIN 1 ORIENTATION IN TAPE



\*All dimensions are nominal

Device	Package Type	Package Drawing	Pins	SPQ	Reel Diameter (mm)	Reel Width W1 (mm)	A0 (mm)	B0 (mm)	K0 (mm)	P1 (mm)	W (mm)	Pin1 Quadrant
BQ27620YZFT-G1	DSBGA	YZF	15	250	180.0	8.4	2.1	2.76	0.81	4.0	8.0	Q1

TAPE AND REEL BOX DIMENSIONS

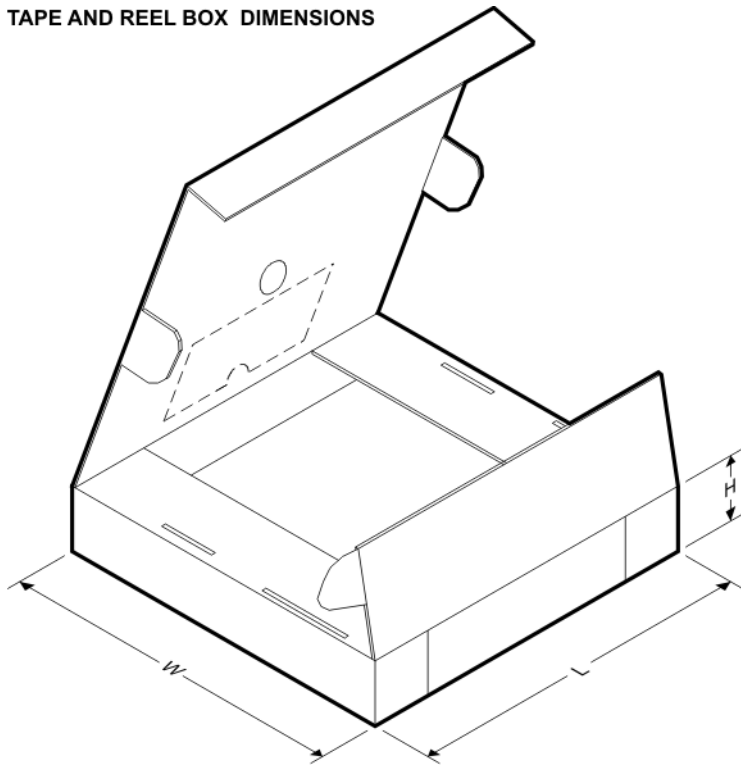

\*All dimensions are nominal

Device	Package Type	Package Drawing	Pins	SPQ	Length (mm)	Width (mm)	Height (mm)
BQ27620YZFT-G1	DSBGA	YZF	15	250	182.0	182.0	20.0

YZF0015

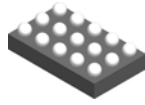

PACKAGE OUTLINE

DSBGA - 0.625 mm max height

DIE SIZE BALL GRID ARRAY

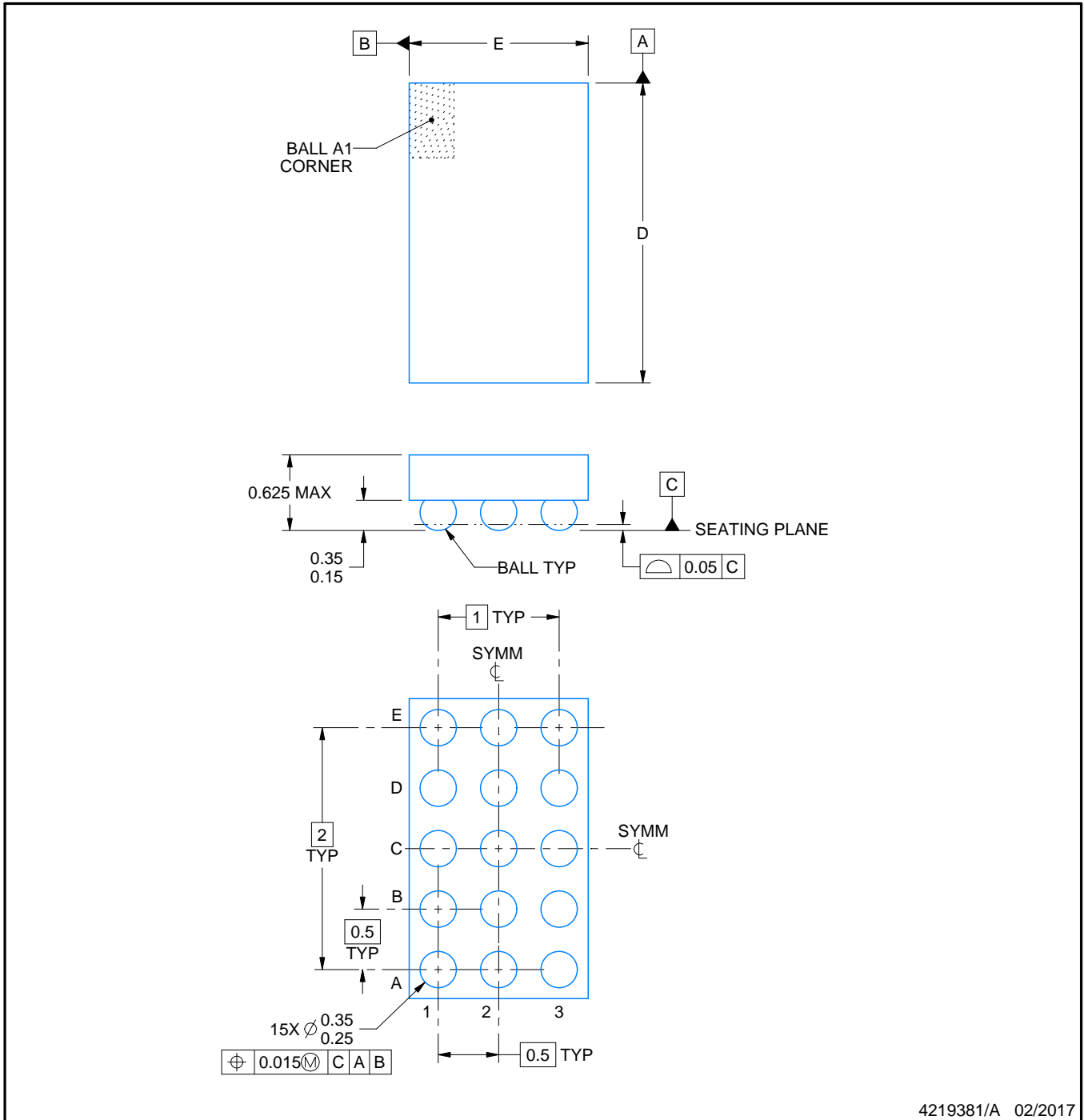

4219381/A 02/2017

NOTES:

NanoFree is a trademark of Texas Instruments.

1. All linear dimensions are in millimeters. Any dimensions in parenthesis are for reference only. Dimensioning and tolerancing per ASME Y14.5M.
2. This drawing is subject to change without notice.
3. NanoFree™ package configuration.

# EXAMPLE BOARD LAYOUT

YZF0015

DSBGA - 0.625 mm max height

DIE SIZE BALL GRID ARRAY

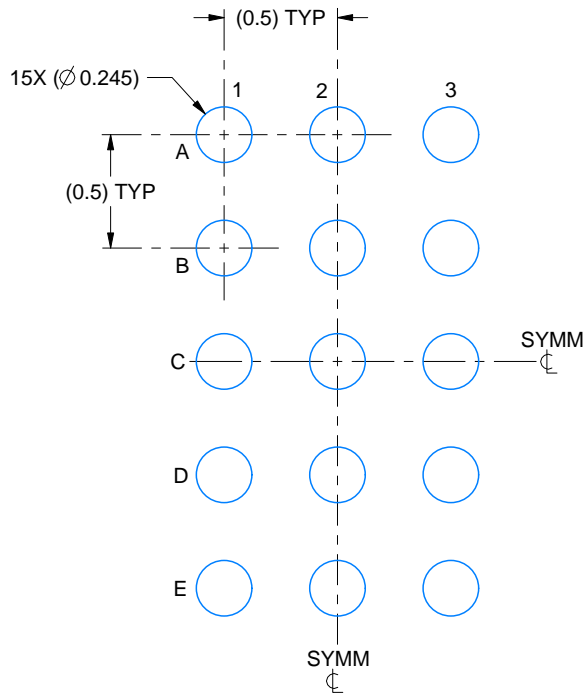

LAND PATTERN EXAMPLE  
EXPOSED METAL SHOWN  
SCALE:30X

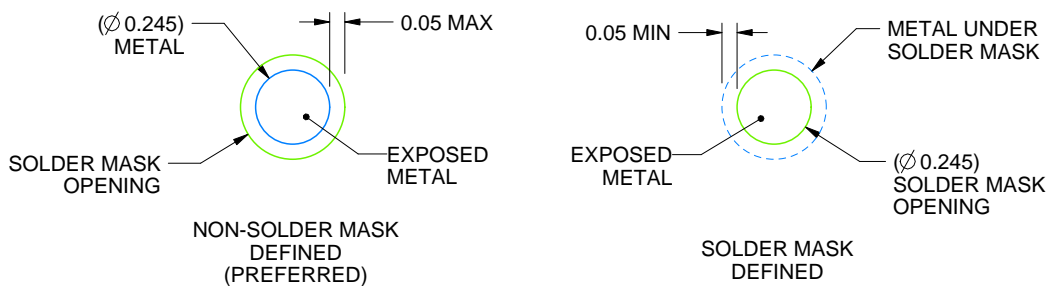

SOLDER MASK DETAILS  
NOT TO SCALE

4219381/A 02/2017

NOTES: (continued)

- Final dimensions may vary due to manufacturing tolerance considerations and also routing constraints. For more information, see Texas Instruments literature number SNVA009 ([www.ti.com/lit/snva009](http://www.ti.com/lit/snva009)).

# EXAMPLE STENCIL DESIGN

YZF0015

DSBGA - 0.625 mm max height

DIE SIZE BALL GRID ARRAY

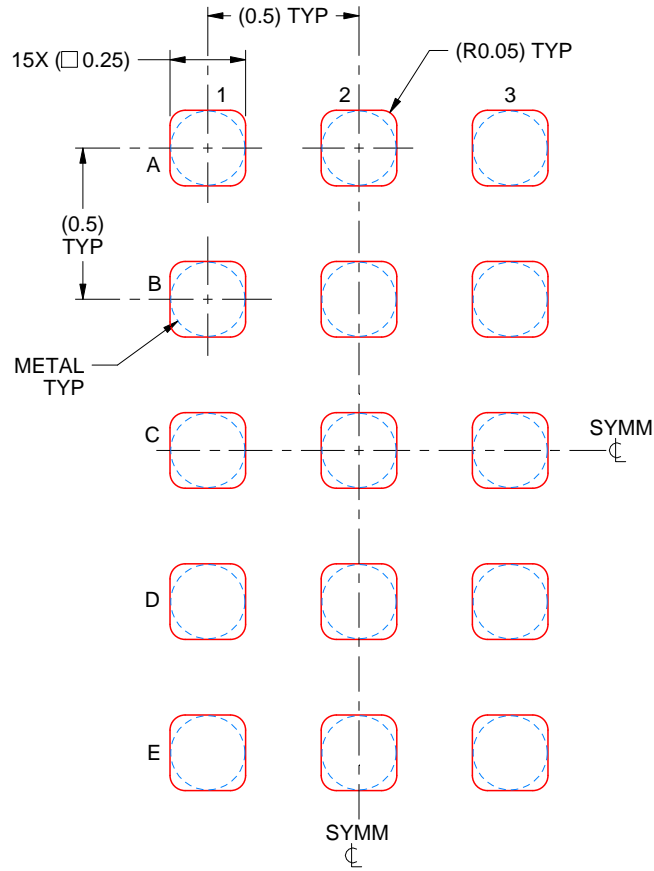

SOLDER PASTE EXAMPLE  
BASED ON 0.1 mm THICK STENCIL  
SCALE:40X

4219381/A 02/2017

NOTES: (continued)

5. Laser cutting apertures with trapezoidal walls and rounded corners may offer better paste release.

## IMPORTANT NOTICE

Texas Instruments Incorporated (TI) reserves the right to make corrections, enhancements, improvements and other changes to its semiconductor products and services per JESD46, latest issue, and to discontinue any product or service per JESD48, latest issue. Buyers should obtain the latest relevant information before placing orders and should verify that such information is current and complete.

TI's published terms of sale for semiconductor products (<http://www.ti.com/sc/docs/stdterms.htm>) apply to the sale of packaged integrated circuit products that TI has qualified and released to market. Additional terms may apply to the use or sale of other types of TI products and services.

Reproduction of significant portions of TI information in TI data sheets is permissible only if reproduction is without alteration and is accompanied by all associated warranties, conditions, limitations, and notices. TI is not responsible or liable for such reproduced documentation. Information of third parties may be subject to additional restrictions. Resale of TI products or services with statements different from or beyond the parameters stated by TI for that product or service voids all express and any implied warranties for the associated TI product or service and is an unfair and deceptive business practice. TI is not responsible or liable for any such statements.

Buyers and others who are developing systems that incorporate TI products (collectively, "Designers") understand and agree that Designers remain responsible for using their independent analysis, evaluation and judgment in designing their applications and that Designers have full and exclusive responsibility to assure the safety of Designers' applications and compliance of their applications (and of all TI products used in or for Designers' applications) with all applicable regulations, laws and other applicable requirements. Designer represents that, with respect to their applications, Designer has all the necessary expertise to create and implement safeguards that (1) anticipate dangerous consequences of failures, (2) monitor failures and their consequences, and (3) lessen the likelihood of failures that might cause harm and take appropriate actions. Designer agrees that prior to using or distributing any applications that include TI products, Designer will thoroughly test such applications and the functionality of such TI products as used in such applications.

TI's provision of technical, application or other design advice, quality characterization, reliability data or other services or information, including, but not limited to, reference designs and materials relating to evaluation modules, (collectively, "TI Resources") are intended to assist designers who are developing applications that incorporate TI products; by downloading, accessing or using TI Resources in any way, Designer (individually or, if Designer is acting on behalf of a company, Designer's company) agrees to use any particular TI Resource solely for this purpose and subject to the terms of this Notice.

TI's provision of TI Resources does not expand or otherwise alter TI's applicable published warranties or warranty disclaimers for TI products, and no additional obligations or liabilities arise from TI providing such TI Resources. TI reserves the right to make corrections, enhancements, improvements and other changes to its TI Resources. TI has not conducted any testing other than that specifically described in the published documentation for a particular TI Resource.

Designer is authorized to use, copy and modify any individual TI Resource only in connection with the development of applications that include the TI product(s) identified in such TI Resource. NO OTHER LICENSE, EXPRESS OR IMPLIED, BY ESTOPPEL OR OTHERWISE TO ANY OTHER TI INTELLECTUAL PROPERTY RIGHT, AND NO LICENSE TO ANY TECHNOLOGY OR INTELLECTUAL PROPERTY RIGHT OF TI OR ANY THIRD PARTY IS GRANTED HEREIN, including but not limited to any patent right, copyright, mask work right, or other intellectual property right relating to any combination, machine, or process in which TI products or services are used. Information regarding or referencing third-party products or services does not constitute a license to use such products or services, or a warranty or endorsement thereof. Use of TI Resources may require a license from a third party under the patents or other intellectual property of the third party, or a license from TI under the patents or other intellectual property of TI.

TI RESOURCES ARE PROVIDED "AS IS" AND WITH ALL FAULTS. TI DISCLAIMS ALL OTHER WARRANTIES OR REPRESENTATIONS, EXPRESS OR IMPLIED, REGARDING RESOURCES OR USE THEREOF, INCLUDING BUT NOT LIMITED TO ACCURACY OR COMPLETENESS, TITLE, ANY EPIDEMIC FAILURE WARRANTY AND ANY IMPLIED WARRANTIES OF MERCHANTABILITY, FITNESS FOR A PARTICULAR PURPOSE, AND NON-INFRINGEMENT OF ANY THIRD PARTY INTELLECTUAL PROPERTY RIGHTS. TI SHALL NOT BE LIABLE FOR AND SHALL NOT DEFEND OR INDEMNIFY DESIGNER AGAINST ANY CLAIM, INCLUDING BUT NOT LIMITED TO ANY INFRINGEMENT CLAIM THAT RELATES TO OR IS BASED ON ANY COMBINATION OF PRODUCTS EVEN IF DESCRIBED IN TI RESOURCES OR OTHERWISE. IN NO EVENT SHALL TI BE LIABLE FOR ANY ACTUAL, DIRECT, SPECIAL, COLLATERAL, INDIRECT, PUNITIVE, INCIDENTAL, CONSEQUENTIAL OR EXEMPLARY DAMAGES IN CONNECTION WITH OR ARISING OUT OF TI RESOURCES OR USE THEREOF, AND REGARDLESS OF WHETHER TI HAS BEEN ADVISED OF THE POSSIBILITY OF SUCH DAMAGES.

Unless TI has explicitly designated an individual product as meeting the requirements of a particular industry standard (e.g., ISO/TS 16949 and ISO 26262), TI is not responsible for any failure to meet such industry standard requirements.

Where TI specifically promotes products as facilitating functional safety or as compliant with industry functional safety standards, such products are intended to help enable customers to design and create their own applications that meet applicable functional safety standards and requirements. Using products in an application does not by itself establish any safety features in the application. Designers must ensure compliance with safety-related requirements and standards applicable to their applications. Designer may not use any TI products in life-critical medical equipment unless authorized officers of the parties have executed a special contract specifically governing such use. Life-critical medical equipment is medical equipment where failure of such equipment would cause serious bodily injury or death (e.g., life support, pacemakers, defibrillators, heart pumps, neurostimulators, and implantables). Such equipment includes, without limitation, all medical devices identified by the U.S. Food and Drug Administration as Class III devices and equivalent classifications outside the U.S.

TI may expressly designate certain products as completing a particular qualification (e.g., Q100, Military Grade, or Enhanced Product). Designers agree that it has the necessary expertise to select the product with the appropriate qualification designation for their applications and that proper product selection is at Designers' own risk. Designers are solely responsible for compliance with all legal and regulatory requirements in connection with such selection.

Designer will fully indemnify TI and its representatives against any damages, costs, losses, and/or liabilities arising out of Designer's non-compliance with the terms and provisions of this Notice.

## Looking for pricing, stock, or lifecycle information?

Click below to explore more details on WIN SOURCE:

 [View BQ27620YZFT-G1](#) on WIN SOURCE

 [Texas Instruments](#) Information

## Optimize Your Supply Chain with WIN SOURCE Solutions

-  Global Sourcing Solution
-  Obsolete Management
-  Cost Control Management
-  Shortage Management
-  Alternative Solution
-  Excess Inventory Management