



**THE DATASHEET OF
BQ27426YZFT**



Table of Contents

1 Features	1	6.13 Typical Characteristics	8
2 Applications	1	7 Detailed Description	9
3 Description	1	7.1 Overview	9
4 Revision History	2	7.2 Functional Block Diagram	9
5 Pin Configuration and Functions	3	7.3 Feature Description	9
6 Specifications	4	7.4 Device Functional Modes	11
6.1 Absolute Maximum Ratings	4	8 Application and Implementation	12
6.2 ESD Ratings	4	8.1 Application Information	12
6.3 Recommended Operating Conditions	5	8.2 Typical Applications	12
6.4 Thermal Information	5	9 Power Supply Recommendation	16
6.5 Supply Current	5	9.1 Power Supply Decoupling	16
6.6 Digital Input and Output DC Characteristics	5	10 Layout	16
6.7 LDO Regulator, Wake-up, and Auto-Shutdown DC Characteristics	6	10.1 Layout Guidelines	16
6.8 LDO Regulator, Wake-up, and Auto-Shutdown AC Characteristics	6	10.2 Layout Example	17
6.9 ADC (Temperature and Cell Measurement) Characteristics	6	11 Device and Documentation Support	18
6.10 Integrating ADC (Coulomb Counter) Characteristics	6	11.1 Documentation Support	18
6.11 I ² C-Compatible Interface Communication Timing Characteristics	6	11.2 Community Resources	18
6.12 SHUTDOWN and WAKE-UP Timing	8	11.3 Trademarks	18
		11.4 Electrostatic Discharge Caution	18
		11.5 Glossary	18
		12 Mechanical, Packaging, and Orderable Information	18

4 Revision History

Changes from Revision D (May 2016) to Revision E	Page
• Added the reference to low-side current sensing	4
• Added the low-side current sense resistor	12
• Added Figure 11	13

Changes from Revision C (February 2016) to Revision D	Page
• Changed Application and Implementation	12
• Changed Design Requirements	13

Changes from Revision B (February 2016) to Revision C	Page
• Changed the Simplified Schematic	1
• Changed the Functional Block Diagram	9

5 Pin Configuration and Functions

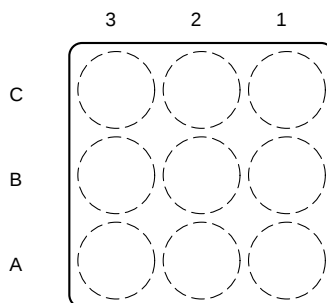
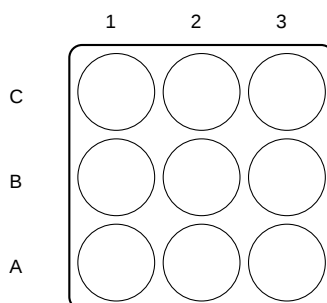
Top View

Bottom View

Pin Functions

PIN		TYPE ⁽¹⁾	DESCRIPTION
NAME	NUMBER		
BAT	C3	PI, AI	LDO regulator input and battery voltage measurement input. Kelvin sense connect to positive battery terminal (PACKP). Connect a capacitor (1 μ F) between BAT and V_{SS} . Place the capacitor close to the gauge.
BIN	B1	DI	Battery insertion detection input. If <i>OpConfig</i> [<i>BI_PU_EN</i>] = 1 (default), a logic low on the pin is detected as battery insertion. For a removable pack, the BIN pin can be connected to V_{SS} through a pull-down resistor on the pack, typically the 10-k Ω thermistor; the system board should use a 1.8-M Ω pull-up resistor to V_{DD} to ensure the BIN pin is high when a battery is removed. If the battery is embedded in the system, it is recommended to leave [<i>BI_PU_EN</i>] = 1 and use a 10-k Ω pull-down resistor from BIN to V_{SS} . If [<i>BI_PU_EN</i>] = 0, then the host must inform the gauge of battery insertion and removal with the <i>BAT_INSERT</i> and <i>BAT_REMOVE</i> subcommands. A 10-k Ω pull-down resistor should be placed between BIN and V_{SS} , even if this pin is unused. NOTE: The BIN pin must not be shorted directly to V_{CC} or V_{SS} and any pullup resistor on the BIN pin must be connected only to V_{DD} and not an external voltage rail. If an external thermistor is used for temperature input, the thermistor should be connected between this pin and V_{SS} .

(1) IO = Digital input-output, AI = Analog input, P = Power connection

Pin Functions (continued)

PIN		TYPE ⁽¹⁾	DESCRIPTION
NAME	NUMBER		
GPOUT	A1	DO	This open-drain output can be configured to indicate BAT_LOW when the <i>OpConfig</i> [BATLOWEN] bit is set. By default [BATLOWEN] is cleared and this pin performs an interrupt function (SOC_INT) by pulsing for specific events, such as a change in state-of-charge. Signal polarity for these functions is controlled by the [GPIOPOL] configuration bit. This pin should not be left floating, even if unused; therefore, a 10-kΩ pullup resistor is recommended. If the device is in SHUTDOWN mode, toggling GPOUT will make the gauge exit SHUTDOWN. It is recommended to connect GPOUT to a GPIO of the host MCU so that in case of any inadvertent shutdown condition, the gauge can be commanded to come out of SHUTDOWN.
SCL	A3	DIO	Slave I ² C serial bus for communication with system (Master). Open-drain pins. Use with external 10-kΩ pullup resistors (typical) for each pin. If the external pullup resistors will be disconnected from these pins during normal operation, recommend using external 1-MΩ pulldown resistors to V _{SS} at each pin to avoid floating inputs.
SDA	A2	DIO	
SRN	C2	AI	Coulomb counter differential inputs expecting an external 10 mΩ, 1% sense resistor in the high-side current path. Kelvin sense connect SRP to the positive battery terminal (PACKP) side of the external sense resistor. Kelvin sense connect SRN to the other side of the external sense resistor, the positive connection to the system (VSYS). No calibration is required. The fuel gauge is precalibrated for a standard 10 mΩ, 1% sense resistor. Low-side current sensing can be enabled. For more information, see Typical Applications .
SRP	C1	AI	
V _{DD}	B3	PO	1.8-V regulator output. Decouple with 2.2-μF ceramic capacitor to V _{SS} . This pin is not intended to provide power for other devices in the system.
V _{SS}	B2	PI	Ground pin

6 Specifications

6.1 Absolute Maximum Ratings

Over operating free-air temperature range (unless otherwise noted)⁽¹⁾

		MIN	MAX	UNIT
V _{BAT}	BAT pin input voltage range	-0.3	6	V
V _{SR}	SRP and SRN pins input voltage range	-0.3	V _{BAT} + 0.3	V
	Differential voltage across SRP and SRN. ABS(SRP – SRN)		2	V
V _{DD}	V _{DD} pin supply voltage range (LDO output)	-0.3	2	V
V _{IOD}	Open-drain IO pins (SDA, SCL)	-0.3	6	V
V _{IOPP}	Push-pull IO pins (BIN)	-0.3	V _{DD} + 0.3	V
T _A	Operating free-air temperature range	-40	85	°C
	Storage temperature, T _{stg}	-65	150	°C

(1) Stresses beyond those listed under "absolute maximum ratings" may cause permanent damage to the device. These are stress ratings only, and functional operation of the device at these or any other conditions beyond those indicated under "recommended operating conditions" is not implied. Exposure to absolute-maximum-rated conditions for extended periods may affect device reliability.

6.2 ESD Ratings

			VALUE	UNIT
V _(ESD)	Electrostatic discharge	Human body model (HBM), per ANSI/ESDA/JEDEC JS-001 ⁽¹⁾	±1500	V
		Charged-device model (CDM), per JEDEC specification JESD22-C101 ⁽²⁾	±250	

(1) JEDEC document JEP155 states that 500-V HBM allows safe manufacturing with a standard ESD control process.

(2) JEDEC document JEP157 states that 250-V CDM allows safe manufacturing with a standard ESD control process.

6.3 Recommended Operating Conditions

 $T_A = 30^\circ\text{C}$ and $V_{\text{REGIN}} = V_{\text{BAT}} = 3.6\text{ V}$ (unless otherwise noted)

			MIN	NOM	MAX	UNIT
$C_{\text{BAT}}^{(1)}$	External input capacitor for internal LDO between BAT and V_{SS}	Nominal capacitor values specified. Recommend a 5% ceramic X5R-type capacitor located close to the device.		0.1		μF
$C_{\text{LDO18}}^{(1)}$	External output capacitor for internal LDO between V_{DD} and V_{SS}			2.2		μF
$V_{\text{PU}}^{(1)}$	External pullup voltage for open-drain pins (SDA, SCL, GPOUT)		1.62		3.6	V

(1) Specified by design. Not production tested.

6.4 Thermal Information

THERMAL METRIC ⁽¹⁾	BQ27426		UNIT
	YZF (DSBGA)		
	9 PINS		
$R_{\theta\text{JA}}$	Junction-to-ambient thermal resistance	64.1	$^\circ\text{C/W}$
$R_{\theta\text{Jctop}}$	Junction-to-case (top) thermal resistance	59.8	$^\circ\text{C/W}$
$R_{\theta\text{JB}}$	Junction-to-board thermal resistance	52.7	$^\circ\text{C/W}$
Ψ_{JT}	Junction-to-top characterization parameter	0.3	$^\circ\text{C/W}$
Ψ_{JB}	Junction-to-board characterization parameter	28.3	$^\circ\text{C/W}$
$R_{\theta\text{Jcbot}}$	Junction-to-case (bottom) thermal resistance	2.4	$^\circ\text{C/W}$

(1) For more information about traditional and new thermal metrics, see the *IC Package Thermal Metrics* application report, [SPRA953](#).

6.5 Supply Current

 $T_A = 30^\circ\text{C}$ and $V_{\text{REGIN}} = V_{\text{BAT}} = 3.6\text{ V}$ (unless otherwise noted)

PARAMETER	TEST CONDITIONS	MIN	TYP	MAX	UNIT
$I_{\text{CC}}^{(1)}$	NORMAL mode current		50		μA
$I_{\text{SLP}}^{(1)}$	SLEEP mode current		9		μA
$I_{\text{SD}}^{(1)}$	SHUTDOWN mode current		0.6		μA

(1) Specified by design. Not production tested.

(2) Wake Comparator Disabled.

6.6 Digital Input and Output DC Characteristics

 $T_A = -40^\circ\text{C}$ to 85°C , typical values at $T_A = 30^\circ\text{C}$ and $V_{\text{REGIN}} = 3.6\text{ V}$ (unless otherwise noted)

PARAMETER	TEST CONDITIONS	MIN	TYP	MAX	UNIT
$V_{\text{IH(OD)}}$	Input voltage, high ⁽²⁾	External pullup resistor to V_{PU}			V
$V_{\text{IH(PP)}}$	Input voltage, high ⁽³⁾			1.4	V
V_{IL}	Input voltage, low ^{(2) (3)}			0.6	V
V_{OL}	Output voltage, low ⁽²⁾			0.6	V
I_{OH}	Output source current, high ⁽²⁾			0.5	mA
$I_{\text{OL(OD)}}$	Output sink current, low ⁽²⁾			-3	mA
$C_{\text{IN}}^{(1)}$	Input capacitance ⁽²⁾⁽³⁾			5	pF
I_{Ikg}	Input Leakage Current (SCL, SDA, BIN, GPOUT)			1	μA

(1) Specified by design. Not production tested.

(2) Open Drain pins: (SCL, SDA, GPOUT)

(3) Push-Pull pin: (BIN)

6.7 LDO Regulator, Wake-up, and Auto-Shutdown DC Characteristics

 $T_A = -40^{\circ}\text{C}$ to 85°C , typical values at $T_A = 30^{\circ}\text{C}$ and $V_{\text{REGIN}} = 3.6\text{ V}$ (unless otherwise noted)

PARAMETER		TEST CONDITIONS	MIN	TYP	MAX	UNIT
V_{BAT}	BAT pin regulator input		2.45		4.5	V
V_{DD}	Regulator output voltage			1.85		V
$\text{UVLO}_{\text{IT+}}$	V_{BAT} undervoltage lock-out LDO wake-up rising threshold			2		V
$\text{UVLO}_{\text{IT-}}$	V_{BAT} undervoltage lock-out LDO auto-shutdown falling threshold			1.95		V
$V_{\text{WU+}}^{(1)}$	GPOUT (input) LDO Wake-up rising edge threshold ⁽²⁾	LDO Wake-up from SHUTDOWN mode	1.2			V

(1) Specified by design. Not production tested.

(2) If the device is commanded to SHUTDOWN via I²C with $V_{\text{BAT}} > \text{UVLO}_{\text{IT+}}$, a wake-up rising edge trigger is required on GPOUT.

6.8 LDO Regulator, Wake-up, and Auto-Shutdown AC Characteristics

 $T_A = -40^{\circ}\text{C}$ to 85°C , typical values at $T_A = 30^{\circ}\text{C}$ and $V_{\text{REGIN}} = 3.6\text{ V}$ (unless otherwise noted)

PARAMETER		TEST CONDITIONS	MIN	TYP	MAX	UNIT
$t_{\text{SHDN}}^{(1)}$	SHUTDOWN entry time	Time delay from SHUTDOWN command to LDO output disable.			250	ms
$t_{\text{SHUP}}^{(1)}$	SHUTDOWN GPOUT low time	Minimum low time of GPOUT (input) in SHUTDOWN before WAKEUP	10			μs
$t_{\text{VDD}}^{(1)}$	Initial V_{DD} output delay			13		ms
$t_{\text{WUVDD}}^{(1)}$	Wake-up V_{DD} output delay	Time delay from rising edge of GPOUT (input) to nominal V_{DD} output		8		ms
t_{PUCD}	Power-up communication delay	Time delay from rising edge of REGIN to the Active state. Includes firmware initialization time		250		ms

(1) Specified by design. Not production tested.

6.9 ADC (Temperature and Cell Measurement) Characteristics

 $T_A = -40^{\circ}\text{C}$ to 85°C ; typical values at $T_A = 30^{\circ}\text{C}$ and $V_{\text{REGIN}} = 3.6\text{ V}$ (unless otherwise noted)

PARAMETER		TEST CONDITIONS	MIN	TYP	MAX	UNIT
$V_{\text{IN(BAT)}}$	BAT pin voltage measurement range	Voltage divider enabled	2.45		4.5	V
$t_{\text{ADC_CONV}}$	Conversion time			125		ms
	Effective resolution			15		bits

(1) Specified by design. Not tested in production.

6.10 Integrating ADC (Coulomb Counter) Characteristics

 $T_A = -40^{\circ}\text{C}$ to 85°C ; typical values at $T_A = 30^{\circ}\text{C}$ and $V_{\text{REGIN}} = 3.6\text{ V}$ (unless otherwise noted)

PARAMETER		TEST CONDITIONS	MIN	TYP	MAX	UNIT
V_{SR}	Input voltage range from BAT to SRP/SRN pins			$\text{BAT} \pm 25$		mV
$t_{\text{SR_CONV}}$	Conversion time	Single conversion		1		s
	Effective Resolution	Single conversion		16		bits

(1) Specified by design. Not tested in production.

6.11 I²C-Compatible Interface Communication Timing Characteristics

 $T_A = -40^{\circ}\text{C}$ to 85°C ; typical values at $T_A = 30^{\circ}\text{C}$ and $V_{\text{REGIN}} = 3.6\text{ V}$ (unless otherwise noted)

		MIN	NOM	MAX	UNIT
Standard Mode (100 kHz)					

(1) Specified by design. Not production tested.

I²C-Compatible Interface Communication Timing Characteristics (continued)

T_A = -40°C to 85°C; typical values at T_A = 30°C and V_{REGIN} = 3.6 V (unless otherwise noted)

		MIN	NOM	MAX	UNIT
t _{d(STA)}	Start to first falling edge of SCL	4			μs
t _{w(L)}	SCL pulse duration (low)	4.7			μs
t _{w(H)}	SCL pulse duration (high)	4			μs
t _{su(STA)}	Setup for repeated start	4.7			μs
t _{su(DAT)}	Data setup time	Host drives SDA	250		ns
t _{h(DAT)}	Data hold time	Host drives SDA	0		ns
t _{su(STOP)}	Setup time for stop	4			μs
t _(BUF)	Bus free time between stop and start	Includes Command Waiting Time	66		μs
t _f	SCL or SDA fall time ⁽¹⁾			300	ns
t _r	SCL or SDA rise time ⁽¹⁾			300	ns
f _{SCL}	Clock frequency ⁽²⁾			100	kHz
Fast Mode (400 kHz)					
t _{d(STA)}	Start to first falling edge of SCL	600			ns
t _{w(L)}	SCL pulse duration (low)	1300			ns
t _{w(H)}	SCL pulse duration (high)	600			ns
t _{su(STA)}	Setup for repeated start	600			ns
t _{su(DAT)}	Data setup time	Host drives SDA	100		ns
t _{h(DAT)}	Data hold time	Host drives SDA	0		ns
t _{su(STOP)}	Setup time for stop	600			ns
t _(BUF)	Bus free time between stop and start	Includes Command Waiting Time	66		μs
t _f	SCL or SDA fall time ⁽¹⁾			300	ns
t _r	SCL or SDA rise time ⁽¹⁾			300	ns
f _{SCL}	Clock frequency ⁽²⁾			400	kHz

(2) If the clock frequency (f_{SCL}) is > 100 kHz, use 1-byte write commands for proper operation. All other transactions types are supported at 400 kHz. (See [I²C Interface](#) and [I²C Command Waiting Time](#).)

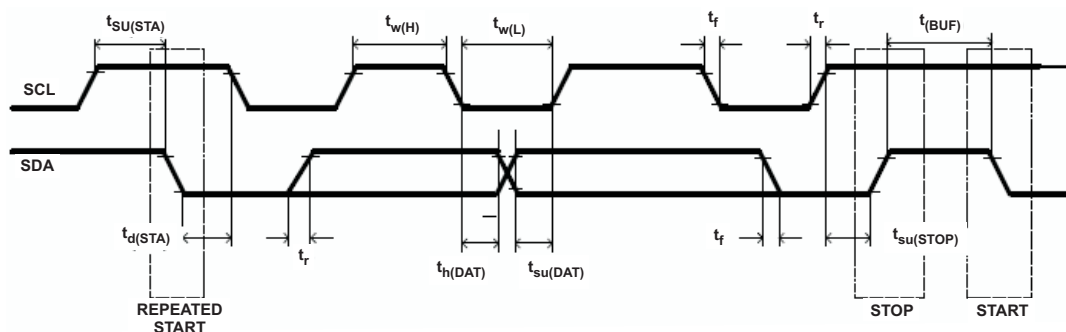
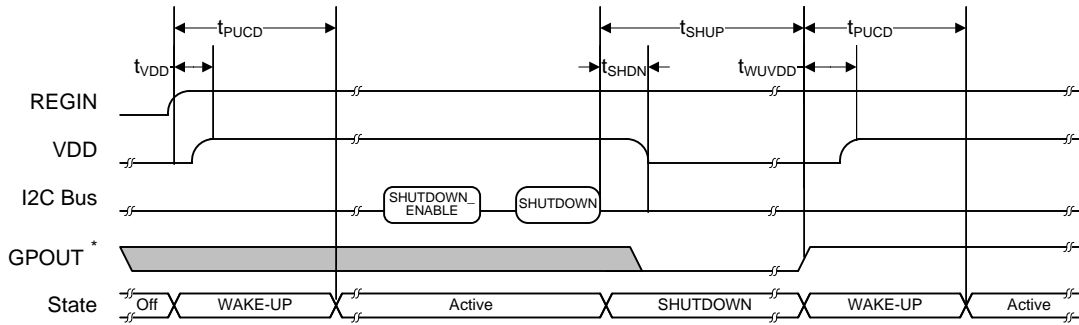

Figure 1. I²C-Compatible Interface Timing Diagrams

6.12 SHUTDOWN and WAKE-UP Timing



* GPOUT is configured as an input for wake-up signaling.

Figure 2. SHUTDOWN and WAKE-UP Timing Diagram

6.13 Typical Characteristics

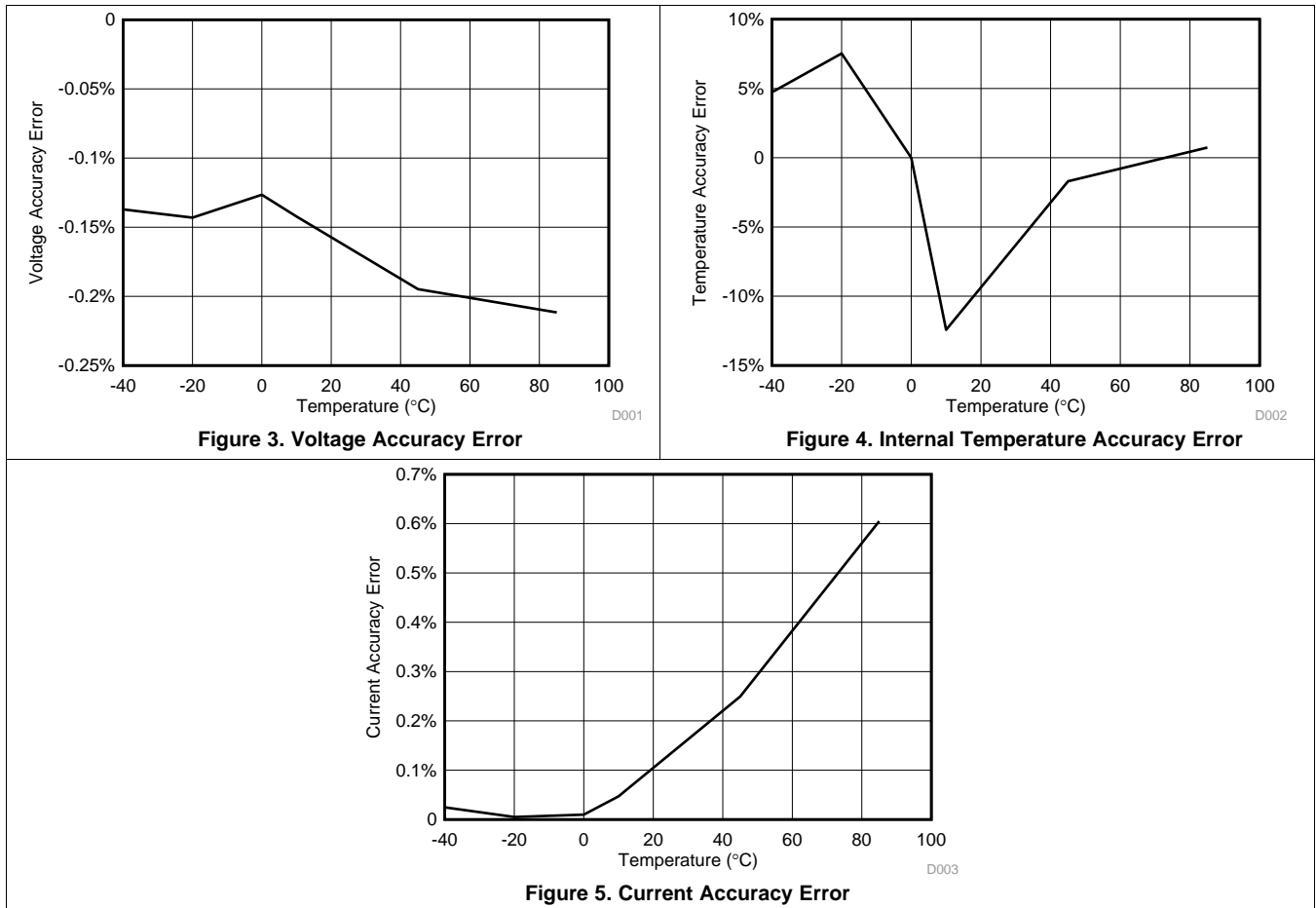

7 Detailed Description

7.1 Overview

The BQ27426 fuel gauge accurately predicts the battery capacity and other operational characteristics of a single Li-based rechargeable cell. It can be interrogated by a system processor to provide cell information, such as state-of-charge (SOC).

NOTE

The following formatting conventions are used in this document:

Commands: *italics* with parentheses() and no breaking spaces, for example, *Control()*.

Data flash: *italics*, **bold**, and breaking spaces, for example, ***Design Capacity***.

Register bits and flags: *italics* with brackets [], for example, *[TDA]*

Data flash bits: *italics*, **bold**, and brackets [], for example, ***[LED1]***

Modes and states: ALL CAPITALS, for example, UNSEALED mode

7.2 Functional Block Diagram

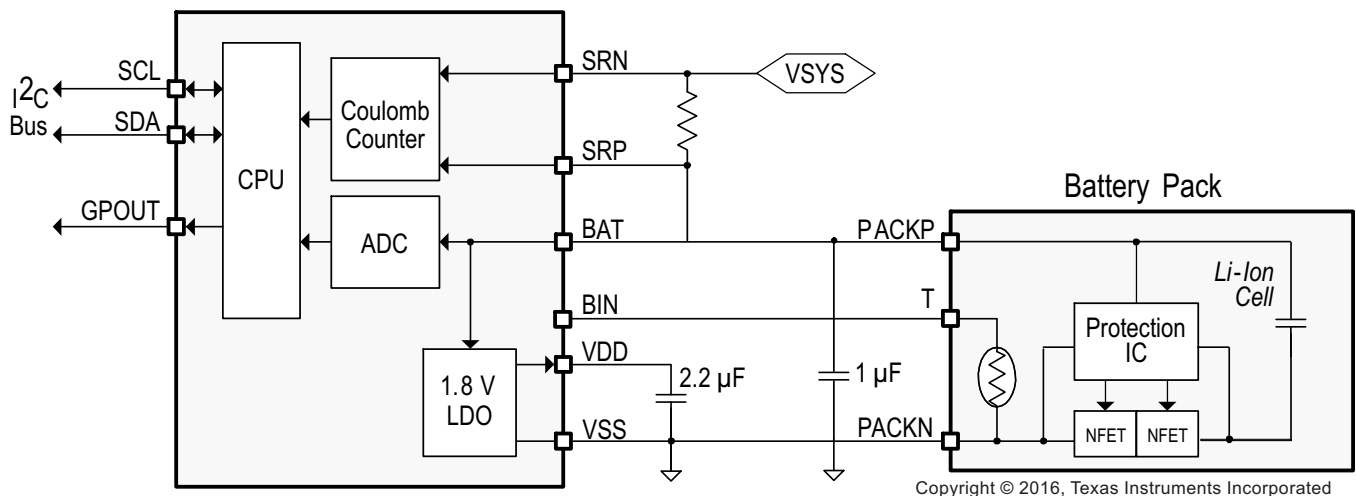

7.3 Feature Description

Information is accessed through a series of commands, called *Standard Commands*. Further capabilities are provided by the additional *Extended Commands* set. Both sets of commands, indicated by the general format *Command*, are used to read and write information contained within the control and status registers, as well as its data locations. Commands are sent from system to gauge using the I²C serial communications engine, and can be executed during application development, system manufacture, or end-equipment operation.

The key to the high-accuracy gas gauging prediction is Texas Instruments proprietary Impedance Track™ algorithm. This algorithm uses cell measurements, characteristics, and properties to create state-of-charge predictions that can achieve high accuracy across a wide variety of operating conditions and over the lifetime of the battery.

The fuel gauge measures the charging and discharging of the battery by monitoring the voltage across a small-value sense resistor. When a cell is attached to the fuel gauge, cell impedance is computed based on cell current, cell open-circuit voltage (OCV), and cell voltage under loading conditions.

The fuel gauge uses an integrated temperature sensor for estimating cell temperature. Alternatively, the host processor can provide temperature data for the fuel gauge.

For more details, see the *BQ27426 Technical Reference Manual (SLUUBB0)*.

Feature Description (continued)

7.3.1 Communications

7.3.1.1 I²C Interface

The fuel gauge supports the standard I²C read, incremental read, quick read, one-byte write, and incremental write functions. The 7-bit device address (ADDR) is the most significant 7 bits of the hex address and is fixed as 1010101. The first 8 bits of the I²C protocol are, therefore, 0xAA or 0xAB for write or read, respectively.

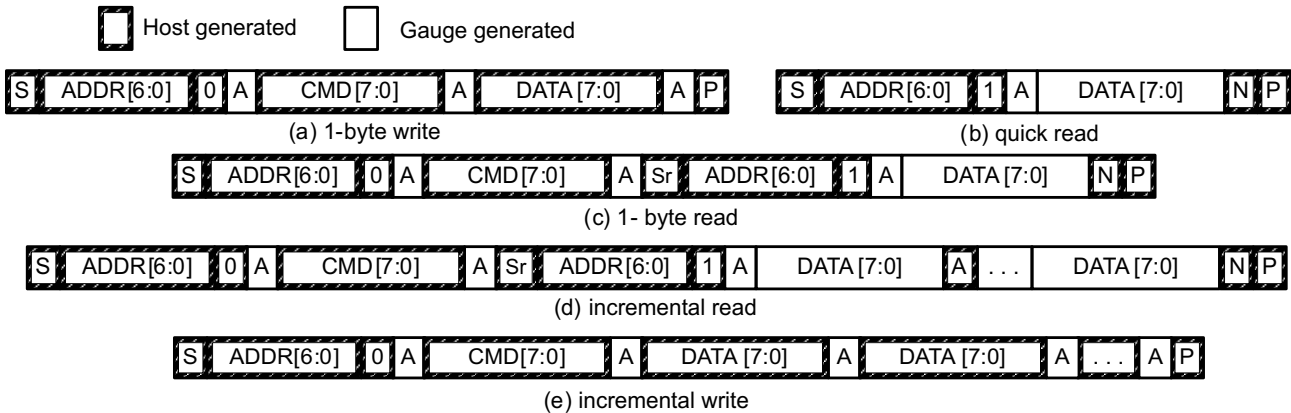

(S = Start, Sr = Repeated Start, A = Acknowledge, N = No Acknowledge, and P = Stop).

Figure 6. I²C Interface

The quick read returns data at the address indicated by the address pointer. The address pointer, a register internal to the I²C communication engine, increments whenever data is acknowledged by the fuel gauge or the I²C master. “Quick writes” function in the same manner and are a convenient means of sending multiple bytes to consecutive command locations (such as two-byte commands that require two bytes of data).

The following command sequences are not supported:

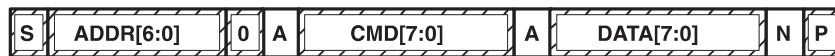

Figure 7. Attempt To Write a Read-only Address (NACK After Data Sent By Master)



Figure 8. Attempt To Read an Address Above 0x6B (NACK Command)

7.3.1.2 I²C Time Out

The I²C engine releases both SDA and SCL if the I²C bus is held low for 2 seconds. If the fuel gauge is holding the lines, releasing them frees them for the master to drive the lines. If an external condition is holding either of the lines low, the I²C engine enters the low-power SLEEP mode.

Feature Description (continued)

7.3.1.3 I²C Command Waiting Time

To ensure proper operation at 400 kHz, a $t_{(BUF)} \geq 66 \mu s$ bus-free waiting time must be inserted between all packets addressed to the fuel gauge. In addition, if the SCL clock frequency (f_{SCL}) is > 100 kHz, use individual 1-byte write commands for proper data flow control. The following diagram shows the standard waiting time required between issuing the control subcommand the reading the status result. For read-write standard command, a minimum of 2 seconds is required to get the result updated. For read-only standard commands, there is no waiting time required, but the host must not issue any standard command more than two times per second. Otherwise, the gauge could result in a reset issue due to the expiration of the watchdog timer.

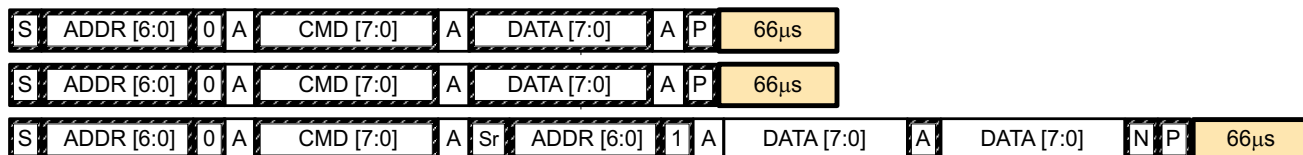

Waiting time inserted between two 1-byte write packets for a subcommand and reading results
(required for $100 \text{ kHz} < f_{SCL} \leq 400 \text{ kHz}$)

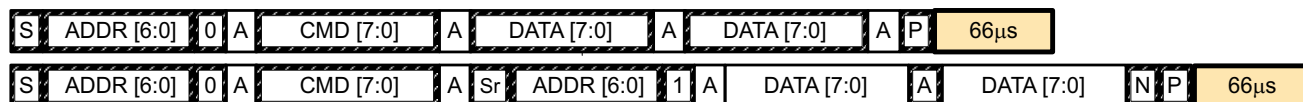

Waiting time inserted between incremental 2-byte write packet for a subcommand and reading results
(acceptable for $f_{SCL} \leq 100 \text{ kHz}$)

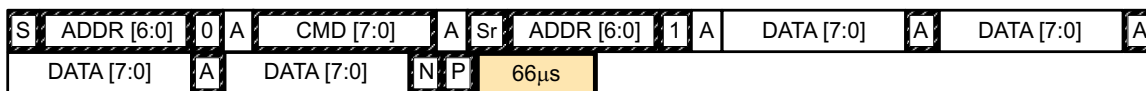

Waiting time inserted after incremental read

Figure 9. I²C Command Waiting Time

7.3.1.4 I²C Clock Stretching

A clock stretch can occur during all modes of fuel gauge operation. In SLEEP mode, a short $\leq 100\text{-}\mu s$ clock stretch occurs on all I²C traffic as the device must wake-up to process the packet. In the other modes (INITIALIZATION, NORMAL), a $\leq 4\text{-ms}$ clock stretching period may occur within packets addressed for the fuel gauge as the I²C interface performs normal data flow control.

7.4 Device Functional Modes

To minimize power consumption, the fuel gauge has several power modes: INITIALIZATION, NORMAL, SLEEP, and SHUTDOWN. The fuel gauge passes automatically between these modes, depending upon the occurrence of specific events, though a system processor can initiate some of these modes directly. For more details, see the *BQ27426 Technical Reference Manual (SLUUBB0)*.

8 Application and Implementation

NOTE

Information in the following application section is not part of the TI component specification, and TI does not warrant its accuracy or completeness. TI's customers are responsible for determining suitability of components for their purposes. Customers should validate and test their design implementation to confirm system functionality.

8.1 Application Information

The BQ27426 fuel gauge is a microcontroller peripheral that provides system-side fuel gauging for single-cell Li-Ion batteries. Battery fuel gauging with the fuel gauge requires connections only to PACK+ and PACK– for a removable battery pack or embedded battery circuit. To allow for optimal performance in the end application, special considerations must be taken to ensure minimization of measurement error through proper printed circuit board (PCB) board layout. Such requirements are detailed in [Design Requirements](#).

8.2 Typical Applications

The BQ27426 device can be used with a high-side current sense resistor (as shown in [Figure 10](#)) or a low-side current sense resistor (as shown in [Figure 11](#)).

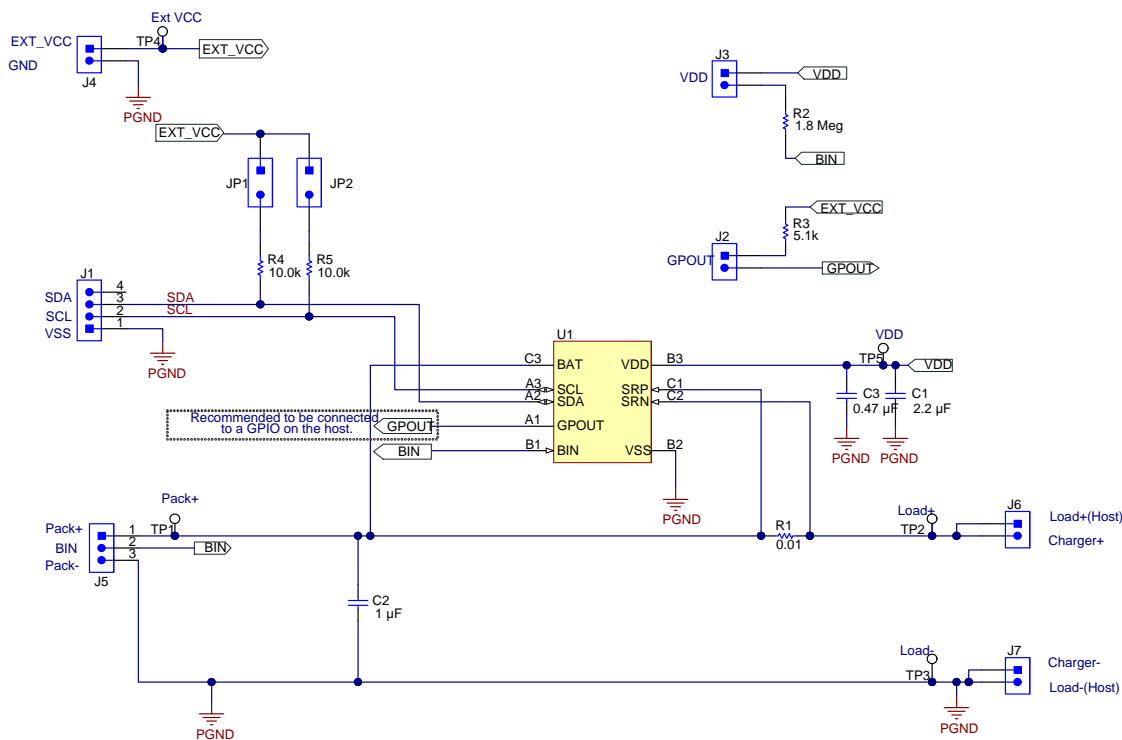

Figure 10. Typical Application with High-Side Current Sense Resistor

Typical Applications (continued)

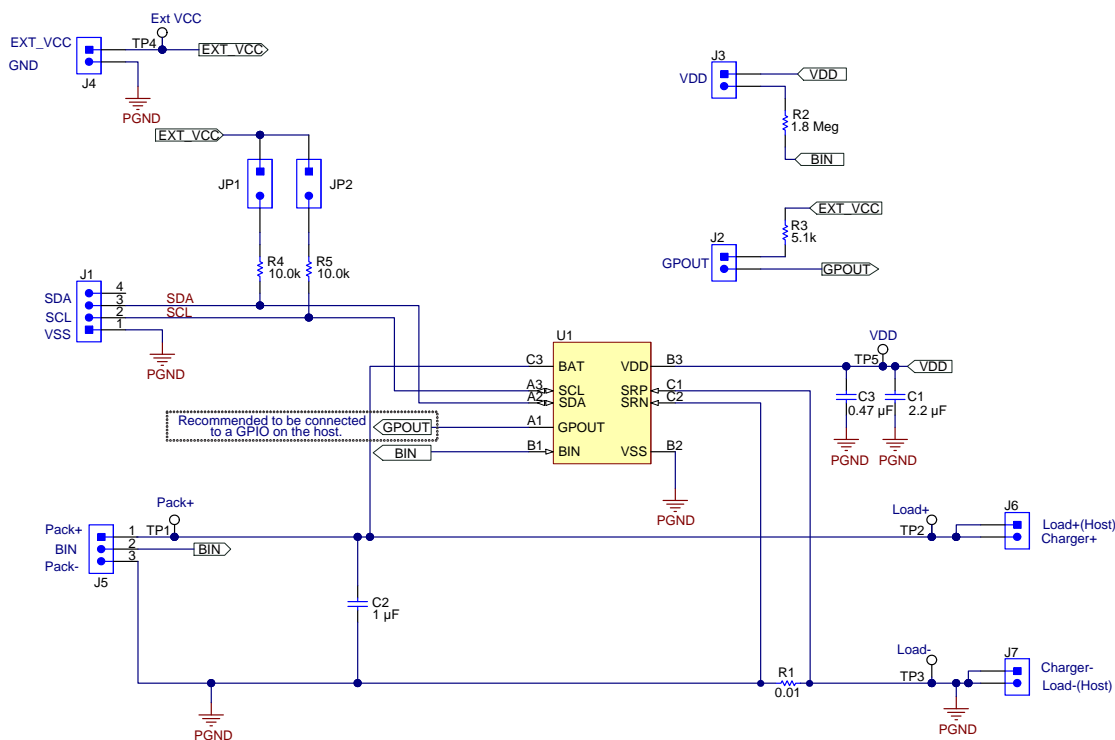

Figure 11. Typical Application with Low-Side Current Sense Resistor

8.2.1 Design Requirements

As shipped from the Texas Instruments factory, the BQ27426 fuel gauge comes with three preprogrammed chemistry profiles and gauging parameters in ROM. Upon device reset, the contents of ROM are copied to associated volatile RAM-based data memory blocks. For proper operation, all parameters in RAM-based data memory require initialization. This can be done by updating data memory parameters in a lab/evaluation situation or by downloading the parameters from a host. The *BQ27426 Technical Reference Manual (SLUUBB0)* shows the default and typically expected values appropriate for most applications.

8.2.2 Detailed Design Procedure

8.2.2.1 BAT Voltage Sense Input

A ceramic capacitor at the input to the BAT pin is used to bypass AC voltage ripple to ground, greatly reducing its influence on battery voltage measurements. It proves most effective in applications with load profiles that exhibit high-frequency current pulses (that is, cell phones) but is recommended for use in all applications to reduce noise on this sensitive high-impedance measurement node.

8.2.2.2 Integrated LDO Capacitor

The fuel gauge has an integrated LDO with an output on the V_{DD} pin of approximately 1.8 V. A capacitor of value at least 2.2 μF should be connected between the V_{DD} pin and V_{SS}. The capacitor must be placed close to the gauge IC and have short traces to both the V_{DD} pin and V_{SS}. This regulator must not be used to provide power for other devices in the system.

Typical Applications (continued)

8.2.2.3 Sense Resistor Selection

Any variation encountered in the resistance present between the SRP and SRN pins of the fuel gauge will affect the resulting differential voltage, and derived current, it senses. As such, it is recommended to select a sense resistor with minimal tolerance and temperature coefficient of resistance (TCR) characteristics. The standard recommendation based on best compromise between performance and price is a 1% tolerance, 50 ppm drift sense resistor with a 1-W power rating.

8.2.3 External Thermistor Support

The fuel gauge temperature sensing circuitry is designed to work with a negative temperature coefficient-type (NTC) thermistor with a characteristic 10-k Ω resistance at room temperature (25°C). The default curve-fitting coefficients configured in the fuel gauge specifically assume a Semitec 103AT type thermistor profile and so that is the default recommendation for thermistor selection purposes. Moving to a separate thermistor resistance profile (for example, JT-2 or others) requires an update to the default thermistor coefficients which can be modified in RAM to ensure highest accuracy temperature measurement performance.

Typical Applications (continued)

8.2.4 Application Curves

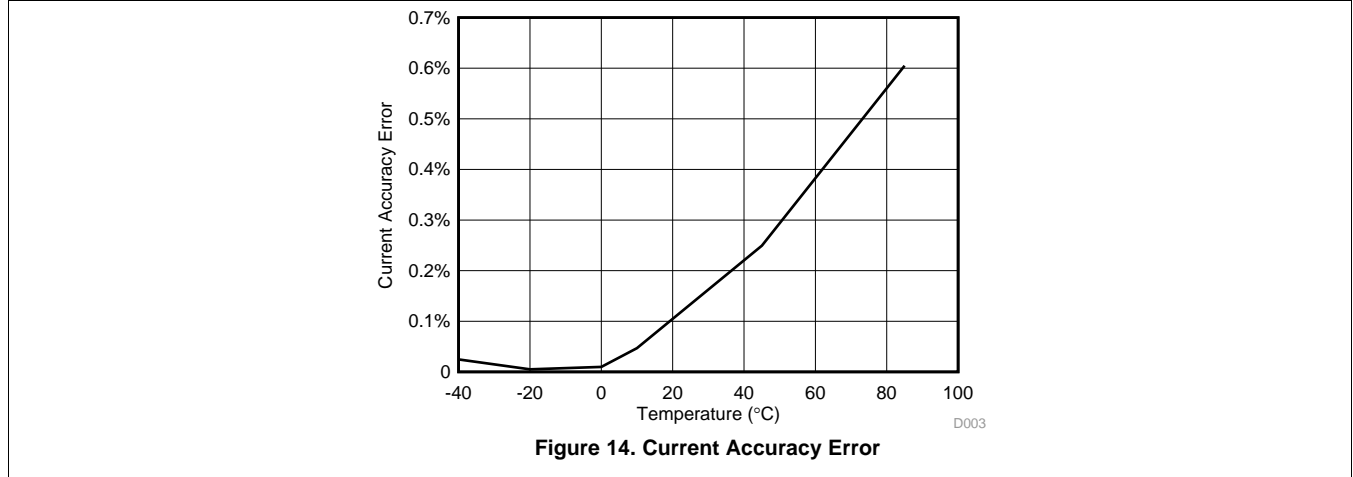
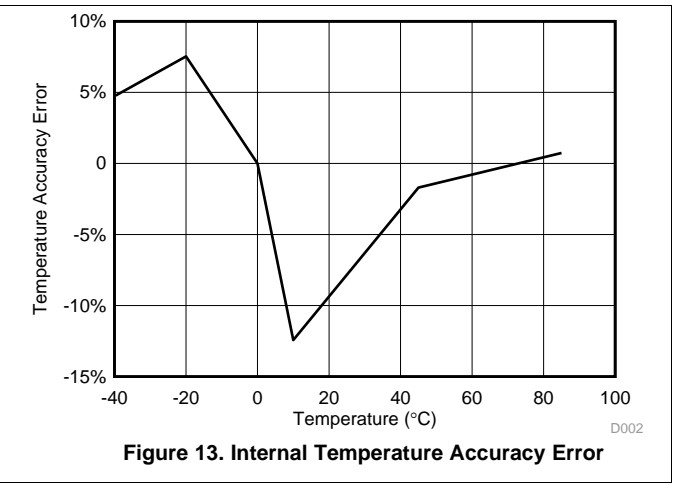
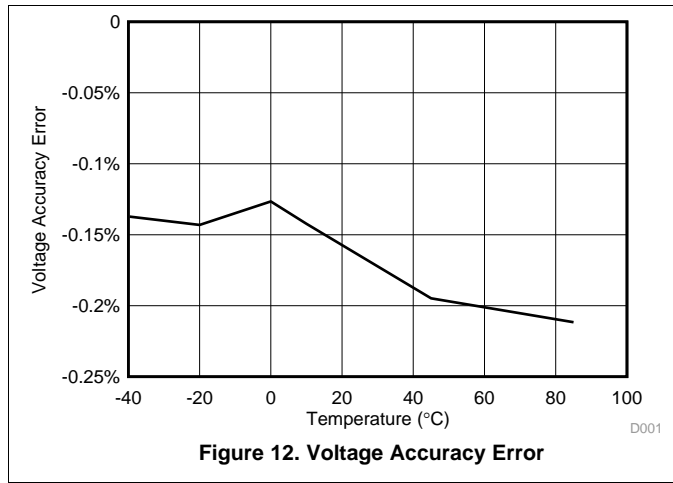

9 Power Supply Recommendation

9.1 Power Supply Decoupling

The battery connection on the BAT pin is used for two purposes:

- To supply power to the fuel gauge
- To provide an input for voltage measurement of the battery.

A capacitor of value of at least 1 μF should be connected between BAT and V_{SS} . The capacitor should be placed close to the gauge IC and have short traces to both the BAT pin and V_{SS} .

The fuel gauge has an integrated LDO with an output on the V_{DD} pin of approximately 1.8 V. A capacitor of value at least 2.2 μF should be connected between the V_{DD} pin and V_{SS} . The capacitor should be placed close to the gauge IC and have short traces to both the V_{DD} pin and V_{SS} . This regulator must not be used to provide power for other devices in the system.

10 Layout

10.1 Layout Guidelines

- A capacitor of a value of at least 2.2 μF is connected between the V_{DD} pin and V_{SS} . The capacitor should be placed close to the gauge IC and have short traces to both the V_{DD} pin and V_{SS} . This regulator must not be used to provide power for other devices in the system.
- It is required to have a capacitor of at least 1.0 μF connect between the BAT pin and V_{SS} if the connection between the battery pack and the gauge BAT pin has the potential to pick up noise. The capacitor should be placed close to the gauge IC and have short traces to both the V_{DD} pin and V_{SS} .
- If the external pullup resistors on the SCL and SDA lines will be disconnected from the host during low-power operation, it is recommended to use external 1-M Ω pulldown resistors to V_{SS} to avoid floating inputs to the I²C engine.
- The value of the SCL and SDA pullup resistors should take into consideration the pullup voltage and the bus capacitance. Some recommended values, assuming a bus capacitance of 10 pF, can be seen in [Table 1](#).

Table 1. Recommended Values for SCL and SDA Pullup Resistors

VPU	1.8 V		3.3 V	
	Range	Typical	Range	Typical
R_{PU}	$400 \Omega \leq R_{\text{PU}} \leq 37.6 \text{ k}\Omega$	10 k Ω	$900 \Omega \leq R_{\text{PU}} \leq 29.2 \text{ k}\Omega$	5.1 k Ω

- If the host is not using the GPOUT functionality, then it is recommended that GPOUT be connected to a GPIO of the host so that in cases where the device is in SHUTDOWN, toggling GPOUT can wake the gauge up from the SHUTDOWN state.
- If the battery pack thermistor is not connected to the BIN pin, the BIN pin should be pulled down to V_{SS} with a 10-k Ω resistor.
- The BIN pin should not be shorted directly to V_{DD} or V_{SS} .
- The actual device ground is pin 3 (V_{SS}).
- The SRP and SRN pins should be Kelvin connected to the R_{SENSE} terminals. SRP to the battery pack side of R_{SENSE} and SRN to the system side of the R_{SENSE} .
- Kelvin connects the BAT pin to the battery PACKP terminal.

10.2 Layout Example

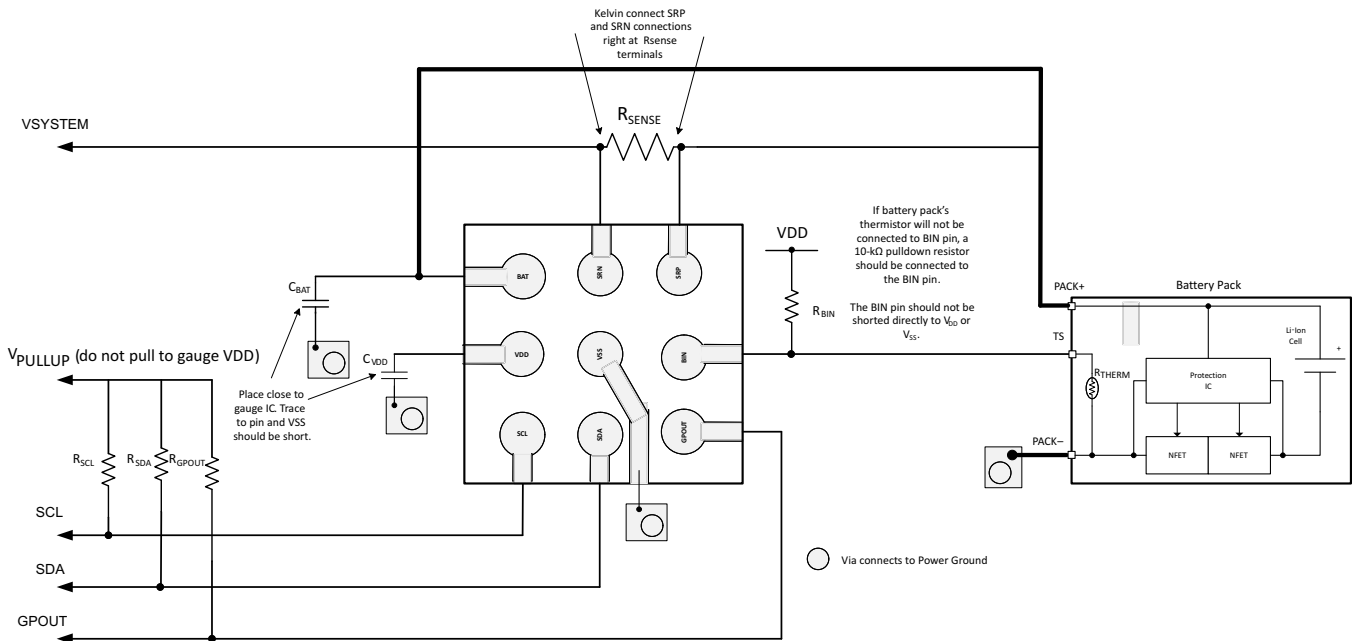

Figure 15. BQ27426 Board Layout

11 Device and Documentation Support

11.1 Documentation Support

11.1.1 Related Documentation

- *BQ27426 Technical Reference Manual* ([SLUUBB0](#))
- *Single Cell Gas Gauge Circuit Design* ([SLUA456](#))
- *Single Cell Impedance Track Printed-Circuit Board Layout Guide* ([SLUA457](#))
- *ESD and RF Mitigation in Handheld Battery Electronics* ([SLUA460](#))

11.2 Community Resources

The following links connect to TI community resources. Linked contents are provided "AS IS" by the respective contributors. They do not constitute TI specifications and do not necessarily reflect TI's views; see TI's [Terms of Use](#).

TI E2E™ Online Community *TI's Engineer-to-Engineer (E2E) Community*. Created to foster collaboration among engineers. At [e2e.ti.com](#), you can ask questions, share knowledge, explore ideas and help solve problems with fellow engineers.

Design Support *TI's Design Support* Quickly find helpful E2E forums along with design support tools and contact information for technical support.

11.3 Trademarks

Impedance Track, NanoFree, E2E are trademarks of Texas Instruments. All other trademarks are the property of their respective owners.

11.4 Electrostatic Discharge Caution



This integrated circuit can be damaged by ESD. Texas Instruments recommends that all integrated circuits be handled with appropriate precautions. Failure to observe proper handling and installation procedures can cause damage.

ESD damage can range from subtle performance degradation to complete device failure. Precision integrated circuits may be more susceptible to damage because very small parametric changes could cause the device not to meet its published specifications.

11.5 Glossary

[SLYZ022](#) — *TI Glossary*.

This glossary lists and explains terms, acronyms, and definitions.

12 Mechanical, Packaging, and Orderable Information

The following pages include mechanical, packaging, and orderable information. This information is the most current data available for the designated devices. This data is subject to change without notice and revision of this document. For browser-based versions of this data sheet, refer to the left-hand navigation.

PACKAGING INFORMATION

Orderable Device	Status (1)	Package Type	Package Drawing	Pins	Package Qty	Eco Plan (2)	Lead/Ball Finish (6)	MSL Peak Temp (3)	Op Temp (°C)	Device Marking (4/5)	Samples
BQ27426YZFR	ACTIVE	DSBGA	YZF	9	3000	Green (RoHS & no Sb/Br)	SNAGCU	Level-1-260C-UNLIM	-40 to 85	BQ27426	Samples
BQ27426YZFT	ACTIVE	DSBGA	YZF	9	250	Green (RoHS & no Sb/Br)	SNAGCU	Level-1-260C-UNLIM	-40 to 85	BQ27426	Samples

(1) The marketing status values are defined as follows:

ACTIVE: Product device recommended for new designs.

LIFEBUY: TI has announced that the device will be discontinued, and a lifetime-buy period is in effect.

NRND: Not recommended for new designs. Device is in production to support existing customers, but TI does not recommend using this part in a new design.

PREVIEW: Device has been announced but is not in production. Samples may or may not be available.

OBsolete: TI has discontinued the production of the device.

(2) **RoHS:** TI defines "RoHS" to mean semiconductor products that are compliant with the current EU RoHS requirements for all 10 RoHS substances, including the requirement that RoHS substance do not exceed 0.1% by weight in homogeneous materials. Where designed to be soldered at high temperatures, "RoHS" products are suitable for use in specified lead-free processes. TI may reference these types of products as "Pb-Free".

RoHS Exempt: TI defines "RoHS Exempt" to mean products that contain lead but are compliant with EU RoHS pursuant to a specific EU RoHS exemption.

Green: TI defines "Green" to mean the content of Chlorine (Cl) and Bromine (Br) based flame retardants meet JS709B low halogen requirements of <=1000ppm threshold. Antimony trioxide based flame retardants must also meet the <=1000ppm threshold requirement.

(3) MSL, Peak Temp. - The Moisture Sensitivity Level rating according to the JEDEC industry standard classifications, and peak solder temperature.

(4) There may be additional marking, which relates to the logo, the lot trace code information, or the environmental category on the device.

(5) Multiple Device Markings will be inside parentheses. Only one Device Marking contained in parentheses and separated by a "~" will appear on a device. If a line is indented then it is a continuation of the previous line and the two combined represent the entire Device Marking for that device.

(6) Lead/Ball Finish - Orderable Devices may have multiple material finish options. Finish options are separated by a vertical ruled line. Lead/Ball Finish values may wrap to two lines if the finish value exceeds the maximum column width.

Important Information and Disclaimer:The information provided on this page represents TI's knowledge and belief as of the date that it is provided. TI bases its knowledge and belief on information provided by third parties, and makes no representation or warranty as to the accuracy of such information. Efforts are underway to better integrate information from third parties. TI has taken and continues to take reasonable steps to provide representative and accurate information but may not have conducted destructive testing or chemical analysis on incoming materials and chemicals. TI and TI suppliers consider certain information to be proprietary, and thus CAS numbers and other limited information may not be available for release.

In no event shall TI's liability arising out of such information exceed the total purchase price of the TI part(s) at issue in this document sold by TI to Customer on an annual basis.

TAPE AND REEL INFORMATION



QUADRANT ASSIGNMENTS FOR PIN 1 ORIENTATION IN TAPE



*All dimensions are nominal

Device	Package Type	Package Drawing	Pins	SPQ	Reel Diameter (mm)	Reel Width W1 (mm)	A0 (mm)	B0 (mm)	K0 (mm)	P1 (mm)	W (mm)	Pin1 Quadrant
BQ27426YZFR	DSBGA	YZF	9	3000	180.0	8.4	1.78	1.78	0.69	4.0	8.0	Q1
BQ27426YZFT	DSBGA	YZF	9	250	180.0	8.4	1.78	1.78	0.69	4.0	8.0	Q1

TAPE AND REEL BOX DIMENSIONS

*All dimensions are nominal

Device	Package Type	Package Drawing	Pins	SPQ	Length (mm)	Width (mm)	Height (mm)
BQ27426YZFR	DSBGA	YZF	9	3000	182.0	182.0	20.0
BQ27426YZFT	DSBGA	YZF	9	250	182.0	182.0	20.0

EXAMPLE BOARD LAYOUT

YZF0009

DSBGA - 0.625 mm max height

DIE SIZE BALL GRID ARRAY

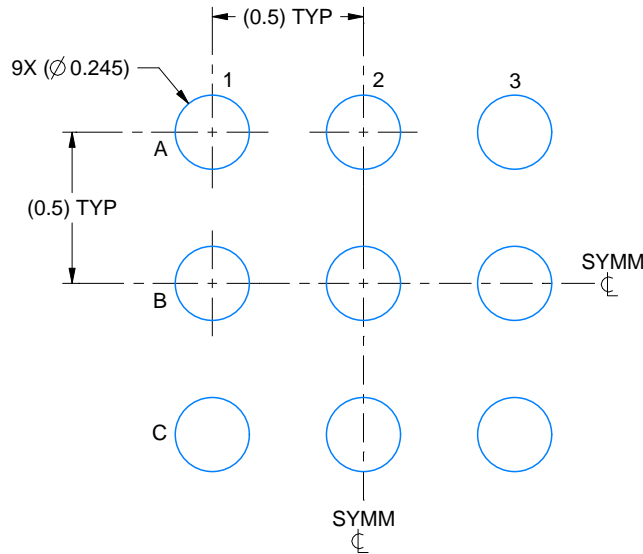

LAND PATTERN EXAMPLE
EXPOSED METAL SHOWN
SCALE: 40X

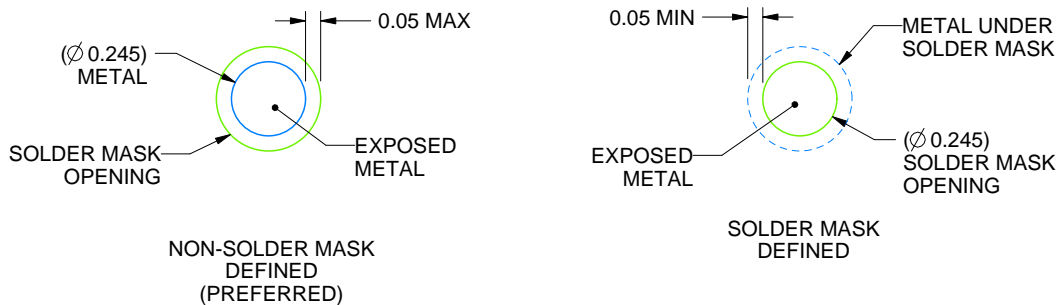

SOLDER MASK DETAILS
NOT TO SCALE

4219558/A 10/2018

NOTES: (continued)

- 3. Final dimensions may vary due to manufacturing tolerance considerations and also routing constraints. See Texas Instruments Literature No. SNVA009 (www.ti.com/lit/snva009).

EXAMPLE STENCIL DESIGN

YZF0009

DSBGA - 0.625 mm max height

DIE SIZE BALL GRID ARRAY

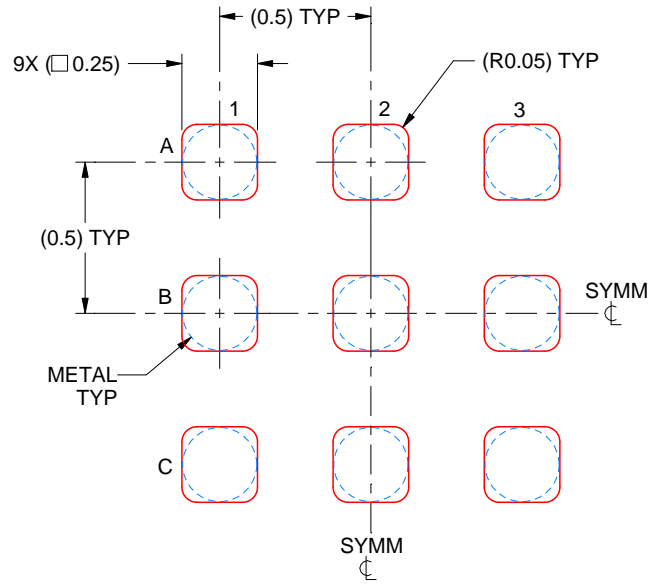

SOLDER PASTE EXAMPLE
BASED ON 0.1 mm THICK STENCIL
SCALE: 40X

4219558/A 10/2018

NOTES: (continued)

4. Laser cutting apertures with trapezoidal walls and rounded corners may offer better paste release.

IMPORTANT NOTICE AND DISCLAIMER

TI PROVIDES TECHNICAL AND RELIABILITY DATA (INCLUDING DATASHEETS), DESIGN RESOURCES (INCLUDING REFERENCE DESIGNS), APPLICATION OR OTHER DESIGN ADVICE, WEB TOOLS, SAFETY INFORMATION, AND OTHER RESOURCES "AS IS" AND WITH ALL FAULTS, AND DISCLAIMS ALL WARRANTIES, EXPRESS AND IMPLIED, INCLUDING WITHOUT LIMITATION ANY IMPLIED WARRANTIES OF MERCHANTABILITY, FITNESS FOR A PARTICULAR PURPOSE OR NON-INFRINGEMENT OF THIRD PARTY INTELLECTUAL PROPERTY RIGHTS.

These resources are intended for skilled developers designing with TI products. You are solely responsible for (1) selecting the appropriate TI products for your application, (2) designing, validating and testing your application, and (3) ensuring your application meets applicable standards, and any other safety, security, or other requirements. These resources are subject to change without notice. TI grants you permission to use these resources only for development of an application that uses the TI products described in the resource. Other reproduction and display of these resources is prohibited. No license is granted to any other TI intellectual property right or to any third party intellectual property right. TI disclaims responsibility for, and you will fully indemnify TI and its representatives against, any claims, damages, costs, losses, and liabilities arising out of your use of these resources.

TI's products are provided subject to TI's Terms of Sale (www.ti.com/legal/termsofsale.html) or other applicable terms available either on ti.com or provided in conjunction with such TI products. TI's provision of these resources does not expand or otherwise alter TI's applicable warranties or warranty disclaimers for TI products.

Mailing Address: Texas Instruments, Post Office Box 655303, Dallas, Texas 75265
Copyright © 2019, Texas Instruments Incorporated

Looking for pricing, stock, or lifecycle information?

Click below to explore more details on WIN SOURCE:

 [View BQ27426YZFT](#) on WIN SOURCE

 [Texas Instruments](#) Information

Optimize Your Supply Chain with WIN SOURCE Solutions

-  Global Sourcing Solution
-  Obsolete Management
-  Cost Control Management
-  Shortage Management
-  Alternative Solution
-  Excess Inventory Management