



**THE DATASHEET OF
BQ24620RVAT**



bq24620 Stand-Alone Synchronous Switched-Mode Lithium Phosphate Battery Charger With Low I_q

1 Features

- 300-kHz NMOS-NMOS Synchronous Buck Converter
- Stand-Alone Charger Designed Specifically for Lithium Phosphate
- 5-V to 28-V VCC Operating Range, Supports 1 to 7 Battery Cells
- High-Accuracy Voltage and Current Regulation
 - $\pm 0.5\%$ Charge Voltage Accuracy
 - $\pm 3\%$ Charge Current Accuracy
- Integration
 - Internal Loop Compensation
 - Internal Soft Start
- Safety
 - Input Overvoltage Protection
 - Battery Thermistor Sense Suspend Charge at Hot/Cold Charge Suspend and Automatically $I_{CHARGE}/8$ at WARM/COOL
 - Battery Detection
 - Built-In Safety Timer
 - Charge Overcurrent Protection
 - Battery Short Protection
 - Battery Overvoltage Protection
 - Thermal Shutdown
- Status Outputs
 - Adapter Present
 - Charger Operation Status
- Charge Enable Pin
- 6-V Gate Drive for Synchronous Buck Converter
- 30-ns Driver Dead Time and 99.95% Maximum Effective Duty Cycle
- 16-Pin 3.5-mm x 3.5-mm QFN Package
- Energy Star Low I_q
 - $< 15\text{-}\mu\text{A}$ Off-State Battery Discharge Current
 - $< 1.5\text{-mA}$ Off-State Input Quiescent Current

2 Applications

- Power Tools and Portable Equipment
- Personal Digital Assistants
- Handheld Terminals
- Industrial and Medical Equipment
- Netbooks, Mobile Internet Devices, and Ultramobile PCs

3 Description

The bq24620 device is a highly integrated lithium phosphate switched-mode battery charge controller. The device offers a constant-frequency synchronous switching PWM controller with high-accuracy charge current and voltage regulation, charge preconditioning, termination, and charge status monitoring.

The bq24620 charges the battery in three phases: preconditioning, constant current, and constant voltage.

Device Information⁽¹⁾

| PART NUMBER | PACKAGE | BODY SIZE (NOM) |
|-------------|-----------|-------------------|
| bq24620 | VQFN (16) | 3.50 mm x 3.50 mm |

(1) For all available packages, see the orderable addendum at the end of the data sheet.

Simplified Schematic

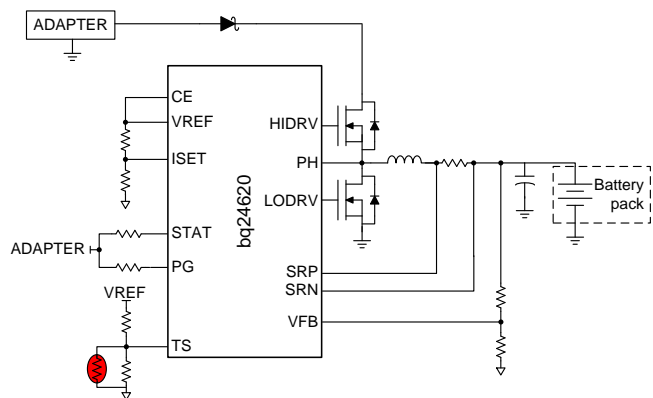

Table of Contents

| | | | |
|--|-----------|--|-----------|
| 1 Features | 1 | 8.4 Device Functional Modes..... | 22 |
| 2 Applications | 1 | 9 Application and Implementation | 23 |
| 3 Description | 1 | 9.1 Application Information..... | 23 |
| 4 Revision History | 2 | 9.2 Typical Application | 23 |
| 5 Device Comparison Table | 3 | 10 Power Supply Recommendations | 29 |
| 6 Pin Configuration and Functions | 3 | 11 Layout | 29 |
| 7 Specifications | 4 | 11.1 Layout Guidelines | 29 |
| 7.1 Absolute Maximum Ratings | 4 | 11.2 Layout Example | 30 |
| 7.2 ESD Ratings..... | 5 | 12 Device and Documentation Support | 31 |
| 7.3 Recommended Operating Conditions..... | 5 | 12.1 Device Support..... | 31 |
| 7.4 Thermal Information | 5 | 12.2 Documentation Support | 31 |
| 7.5 Electrical Characteristics..... | 5 | 12.3 Community Resources..... | 31 |
| 7.6 Typical Characteristics..... | 9 | 12.4 Trademarks | 31 |
| 8 Detailed Description | 11 | 12.5 Electrostatic Discharge Caution..... | 31 |
| 8.1 Overview | 11 | 12.6 Glossary | 31 |
| 8.2 Functional Block Diagram | 12 | 13 Mechanical, Packaging, and Orderable | 31 |
| 8.3 Feature Description..... | 13 | Information | 31 |

4 Revision History

Changes from Revision A (October 2011) to Revision B

Page

- Added *ESD Ratings* table, *Feature Description* section, *Device Functional Modes*, *Application and Implementation* section, *Power Supply Recommendations* section, *Layout* section, *Device and Documentation Support* section, and *Mechanical, Packaging, and Orderable Information* section

1

Changes from Original (March 2010) to Revision A

Page

- Changed description for PH and BTST pins
- Replaced Thermal Information table
- Corrected [Equation 11](#)

4
5
24

5 Device Comparison Table

| | bq24620 | bq24630 |
|--|-------------------|---------------------|
| Cell chemistry | Lithium phosphate | Lithium phosphate |
| Number of cells in series (minimum to maximum, 4.2 V/cell) | 1 to 7 | 1 to 7 |
| Charge voltage (minimum to maximum) (V) | 1.8 to 26 | 1.8 to 26 |
| Input voltage range (minimum to maximum) (V) | 5 to 28 | 5 to 28 |
| Input overvoltage (V) | 32 | 32 |
| Maximum battery charging current (A) | 10 | 10 |
| Switching frequency (kHz) | 300 | 300 |
| JEITA charging temperature profile | No | No |
| DPM | No | I _{IN} DPM |

6 Pin Configuration and Functions

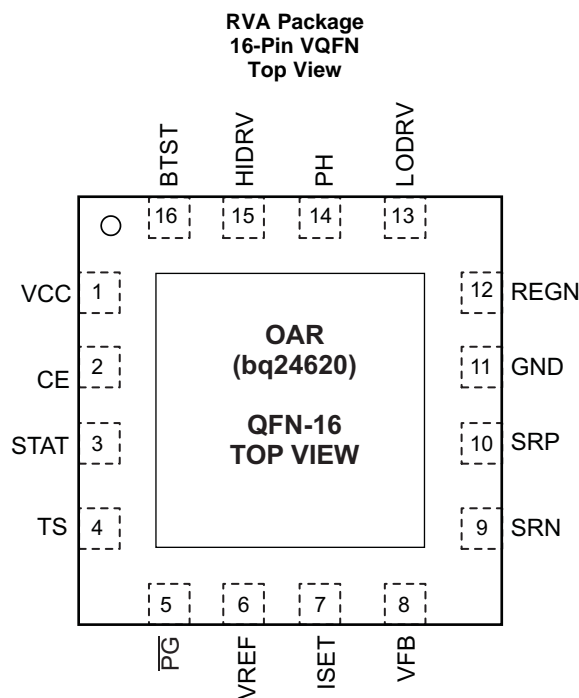

Pin Functions

| PIN | | DESCRIPTION |
|-------|-----|---|
| NAME | NO. | |
| BTST | 16 | PWM high-side driver negative supply. Connect the 0.1- μ F bootstrap capacitor from PH to BTST, and a bootstrap Schottky diode from REGN to BTST. |
| CE | 2 | Charge enable active-HIGH logic input. HI enables charge. LO disables charge. The CE pin has an internal 1-M Ω pulldown resistor. |
| GND | 11 | Low-current sensitive analog/digital ground. On PCB layout, connect with thermal pad underneath the IC. |
| HIDRV | 15 | PWM high-side driver output. Connect to the gate of the high-side power MOSFET with a short trace. |
| ISET | 7 | Charge current set input. The voltage of ISET pin programs the charge current regulation, precharge current and termination current set-point. |
| LODRV | 13 | PWM low-side driver output. Connect to the gate of the low-side power MOSFET with a short trace. |

Pin Functions (continued)

| PIN | | DESCRIPTION |
|------------------------|-----|--|
| NAME | NO. | |
| $\overline{\text{PG}}$ | 5 | Open-drain power good status output. The transistor turns on when a valid VCC is detected. The transistor is turned off in the sleep mode. $\overline{\text{PG}}$ can be used to drive an LED or communicate with a host processor. The $\overline{\text{PG}}$ pin can be used to drive ACFET and BATFET. |
| PH | 14 | PWM high-side driver negative supply. Connect to the phase-switching node (junction of the low-side power MOSFET drain, high-side power MOSFET source, and output inductor). |
| REGN | 12 | PWM low-side driver positive 6-V supply output. Connect a 1- μF ceramic capacitor from REGN to the PGND pin, close to the IC. Use for low-side driver and high-side driver bootstrap voltage by connecting a small-signal Schottky diode from REGN to BTST. |
| SRN | 9 | Charge current sense resistor, negative input. A 0.1- μF ceramic capacitor is placed from SRN to SRP to provide differential-mode filtering. An optional 0.1- μF ceramic capacitor is placed from the SRN pin to GND for common-mode filtering. |
| SRP | 10 | Charge current sense resistor, positive input. A 0.1- μF ceramic capacitor is placed from SRN to SRP to provide differential-mode filtering. A 0.1- μF ceramic capacitor is placed from SRP pin to GND for common-mode filtering. |
| STAT | 3 | Open-drain charge status pin to indicate various charger operations (See Table 2) |
| Thermal pad | — | Exposed pad beneath the IC. Always solder the thermal pad to the board, and have vias on the thermal-pad plane star-connecting to GND and ground plane for high-current power converter. It also serves as a thermal pad to dissipate the heat. |
| TS | 4 | Temperature qualification voltage input for battery pack negative-temperature-coefficient thermistor. Program the hot and cold temperature window with a resistor divider from VREF to TS to GND. |
| VCC | 1 | IC power positive supply. Connect through a 10- Ω resistor to the common-source (diode-OR) point: source of high-side P-channel MOSFET and source of reverse-blocking power P-channel MOSFET. Or connect through a 10- Ω resistor to the cathode of the input diode. Place a 1- μF ceramic capacitor from VCC to GND pin close to the IC. |
| VFB | 8 | Output voltage analog feedback adjustment. Connect the output of a resistive voltage divider from the battery terminals to this node to adjust the output battery regulation voltage. |
| VREF | 6 | 3.3-V regulated voltage output. Place a 1- μF ceramic capacitor from VREF to the GND pin close to the IC. This voltage could be used for programming of voltage and current regulation and for programming the TS threshold. |

7 Specifications

7.1 Absolute Maximum Ratings⁽¹⁾⁽²⁾⁽³⁾

over operating free-air temperature range (unless otherwise noted)

| | | MIN | MAX | UNIT |
|--------------------------------|---|------|-----|------|
| Voltage | VCC, SRP, SRN, CE, STAT, $\overline{\text{PG}}$ | -0.3 | 33 | V |
| | PH | -2 | 36 | |
| | VFB | -0.3 | 16 | |
| | REGN, LODRV, TS | -0.3 | 7 | |
| | BTST, HIDRV with respect to GND | -0.3 | 39 | |
| | VREF, ISET | -0.3 | 3.6 | |
| Maximum difference voltage | SRP-SRN | -0.5 | 0.5 | V |
| Junction temperature, T_J | | -40 | 155 | °C |
| Storage temperature, T_{stg} | | -55 | 155 | °C |

- (1) Stresses beyond those listed under *Absolute Maximum Ratings* may cause permanent damage to the device. These are stress ratings only, and functional operation of the device at these or any other conditions beyond those indicated under *Recommended Operating Conditions* is not implied. Exposure to absolute-maximum-rated conditions for extended periods may affect device reliability.
- (2) All voltages are with respect to GND if not specified. Currents are positive into, negative out of the specified terminal. Consult the packaging section of the data book for thermal limitations and considerations of packages.
- (3) Must have a series resistor between battery pack to VFB if battery pack voltage is expected to be greater than 16 V. Usually the resistor-divider top resistor takes care of this.

7.2 ESD Ratings

| | | VALUE | UNIT |
|-------------------------------------|--|-------|------|
| $V_{(ESD)}$ Electrostatic discharge | Human body model (HBM), per ANSI/ESDA/JEDEC JS-001 ⁽¹⁾ | ±2000 | V |
| | Charged device model (CDM), per JEDEC specification JESD22-C101 ⁽²⁾ | ±500 | |

(1) JEDEC document JEP155 states that 500-V HBM allows safe manufacturing with a standard ESD control process.

(2) JEDEC document JEP157 states that 250-V CDM allows safe manufacturing with a standard ESD control process.

7.3 Recommended Operating Conditions

| | | MIN | NOM | MAX | UNIT |
|-------------------------------|--|------|-----|-----|------|
| Voltage | VCC, SRP, SRN, CE, STAT, \overline{PG} | -0.3 | | 28 | V |
| | PH | -2 | | 30 | |
| | VFB | -0.3 | | 14 | |
| | REGN, LODRV, TS | -0.3 | | 6.5 | |
| | BTST, HIDRV with respect to GND | -0.3 | | 34 | |
| | ISET | -0.3 | | 3.3 | |
| | VREF | | | 3.3 | |
| Maximum difference voltage | SRP–SRN | -0.2 | | 0.2 | V |
| T_J Junction temperature | | 0 | | 125 | °C |
| T_{stg} Storage temperature | | -55 | | 155 | °C |

7.4 Thermal Information

| THERMAL METRIC ⁽¹⁾ | | bq24620 | | UNIT |
|-------------------------------|--|------------|--|------|
| | | RVA [VQFN] | | |
| | | 16 PINS | | |
| $R_{\theta JA}$ | Junction-to-ambient thermal resistance | 43.8 | | °C/W |
| $R_{\theta JC(top)}$ | Junction-to-case (top) thermal resistance | 81 | | °C/W |
| $R_{\theta JB}$ | Junction-to-board thermal resistance | 16 | | °C/W |
| Ψ_{JT} | Junction-to-top characterization parameter | 0.6 | | °C/W |
| Ψ_{JB} | Junction-to-board characterization parameter | 15.77 | | °C/W |
| $R_{\theta JC(bot)}$ | Junction-to-case (bottom) thermal resistance | 4 | | °C/W |

(1) For more information about traditional and new thermal metrics, see the *Semiconductor and IC Package Thermal Metrics* application report, [SPRA953](#).

7.5 Electrical Characteristics

5 V ≤ V_{VCC} ≤ 28 V, 0°C < T_J < 125°C, typical values are at T_A = 25°C, with respect to GND unless otherwise noted

| PARAMETER | TEST CONDITIONS | MIN | TYP | MAX | UNIT |
|----------------------------------|--|--|-----|-----|------|
| OPERATING CONDITIONS | | | | | |
| V_{VCC_OP} | VCC input voltage operating range | 5 | | 28 | V |
| QUIESCENT CURRENTS | | | | | |
| I_{BAT} | Total battery discharge current (sum of currents into VCC, BTST, PH, SRP, SRN, VFB), VFB ≤ 2.1 V | $V_{VCC} < V_{SRN}$, $V_{VCC} > V_{UVLO}$ (SLEEP) | | 15 | µA |
| I_{AC} | Adapter supply current (current into VCC pin) | $V_{VCC} > V_{SRN}$, $V_{VCC} > V_{UVLO}$ CE = LOW (IC quiescent current) | | 1 | 1.5 |
| | | $V_{VCC} > V_{SRN}$, $V_{VCC} > V_{VCCLOW}$, CE = HIGH, charge done | | 2 | 5 |
| | | $V_{VCC} > V_{SRN}$, $V_{VCC} > V_{VCCLOW}$, CE = HIGH, Charging, $Q_{g_total} = 20$ nC, $V_{VCC} = 20$ V | | 12 | |
| CHARGE VOLTAGE REGULATION | | | | | |
| V_{FB} | Feedback regulation voltage | | 1.8 | | V |

Electrical Characteristics (continued)

5 V ≤ V_{VCC} ≤ 28 V, 0°C < T_J < 125°C, typical values are at T_A = 25°C, with respect to GND unless otherwise noted

| PARAMETER | TEST CONDITIONS | MIN | TYP | MAX | UNIT |
|--|--|---|-------------------------|-------|------|
| Charge voltage regulation accuracy | T _J = 0°C to 85°C | -0.5% | | 0.5% | |
| | T _J = -40°C to 125°C | -0.7% | | 0.7% | |
| I _{VFB} | Input leakage current into VFB pin VFB = 1.8 V | | | 100 | nA |
| CURRENT REGULATION – FAST CHARGE | | | | | |
| V _{ISET} | ISET voltage range | 0 | | 2 | V |
| V _{IREG_CHG} | SRP–SRN current-sense voltage range V _{IREG_CHG} = V _{SRP} – V _{SRN} | 0 | | 100 | mV |
| K _{ISET} | Charger current-set factor; amps of charge current per volt on ISET pin) | R _{SENSE} = 10 mΩ | | 5 | A/V |
| | | V _{IREG_CHG} = 40 mV | | -3% | 3% |
| | | V _{IREG_CHG} = 20 mV | | -4% | 4% |
| | | V _{IREG_CHG} = 5 mV | | -25% | 25% |
| | | V _{IREG_CHG} = 1.5 mV (V _{SRN} > 3.1 V) | | -40% | 40% |
| I _{ISET} | Leakage current in to ISET Pin V _{ISET} = 2 V | | | 100 | nA |
| CURRENT REGULATION – PRECHARGE | | | | | |
| | Precharge current R _{SENSE} = 10 mΩ, VFB < V _{LOWV} | 50 | 125 | 200 | mA |
| CHARGE TERMINATION | | | | | |
| | Termination current range R _{SENSE} = 10 mΩ | | I _{CHARGE} /10 | | A |
| K _{TERM} | Termination current-set factor; amps of termination current per volt on ISET pin | | | 0.5 | A/V |
| | | V _{ITERM} = 10 mV | | -10% | 10% |
| | | V _{ITERM} = 5 mV | | -25% | 25% |
| Termination current accuracy | V _{ITERM} = 1.5 mV | | -45% | 45% | |
| | Deglitch time for termination (both edge) | | 100 | | ms |
| t _{QUAL} | Termination qualification time V _{BAT} > V _{RECH} and I _{CHARGE} < I _{TERM} | | 250 | | ms |
| I _{QUAL} | Termination qualification time Discharge current once termination is detected | | 2 | | mA |
| INPUT UNDERVOLTAGE LOCKOUT COMPARATOR (UVLO) | | | | | |
| V _{UVLO} | AC undervoltage rising threshold Measure on VCC | 3.65 | 3.85 | 4 | V |
| V _{UVLO_HYS} | AC undervoltage hysteresis, falling | | 350 | | mV |
| VCC LOWV COMPARATOR | | | | | |
| | Falling threshold, disable charge Measure on VCC | | 4.1 | | V |
| | Rising threshold, resume charge | | 4.35 | 4.5 | V |
| SLEEP COMPARATOR (REVERSE DISCHARGING PROTECTION) | | | | | |
| V _{SLEEP_FALL} | SLEEP falling threshold V _{VCC} – V _{SRN} to enter SLEEP | 40 | 100 | 150 | mV |
| V _{SLEEP_HYS} | SLEEP hysteresis | | 500 | | mV |
| | SLEEP rising delay VCC falling below SRN, delay to pull up \overline{PG} | | 1 | | μs |
| | SLEEP falling delay VCC rising above SRN, delay to pull down \overline{PG} | | 30 | | ms |
| | SLEEP rising shutdown deglitch VCC falling below SRN, Delay to enter SLEEP mode | | 100 | | ms |
| | SLEEP falling powerup deglitch VCC rising above SRN, Delay to come out of SLEEP mode | | 30 | | ms |
| BAT LOWV COMPARATOR | | | | | |
| V _{LOWV} | LOWV rising threshold (precharge to fast charge) Measured on VFB pin | 0.333 | 0.35 | 0.367 | V |
| V _{LOWV_HYS} | LOWV hysteresis | | 100 | | mV |
| | LOWV rising deglitch VFB falling below V _{LOWV} | | 25 | | ms |
| | LOWV falling deglitch VFB rising above V _{LOWV} + V _{LOWV_HYS} | | 25 | | ms |
| RECHARGE COMPARATOR | | | | | |
| V _{RECHG} | Recharge threshold (with respect to V _{REG}) Measured on VFB pin | 110 | 125 | 140 | mV |
| | Recharge rising deglitch VFB decreasing below V _{RECHG} | | 10 | | ms |
| | Recharge falling deglitch VFB increasing above V _{RECHG} | | 10 | | ms |

Electrical Characteristics (continued)

5 V ≤ V_{VCC} ≤ 28 V, 0°C < T_J < 125°C, typical values are at T_A = 25°C, with respect to GND unless otherwise noted

| PARAMETER | | TEST CONDITIONS | MIN | TYP | MAX | UNIT |
|--|---|--|------------------------|------------------------|-------|------|
| BAT OVERVOLTAGE COMPARATOR | | | | | | |
| V _{OV_RISE} | Overvoltage rising threshold | As percentage of V _{FB} | | 108% | | |
| V _{OV_FALL} | Overvoltage falling threshold | As percentage of V _{FB} | | 105% | | |
| INPUT OVERVOLTAGE COMPARATOR (ACOV) | | | | | | |
| V _{ACOV} | AC overvoltage rising threshold on VCC | | 31.04 | 32 | 32.96 | V |
| V _{ACOV_HYS} | AC overvoltage falling hysteresis | | | 1000 | | mV |
| | AC overvoltage rising deglitch | Delay to changing the STAT pins | | 1 | | ms |
| | AC overvoltage falling deglitch | Delay to changing the STAT pins | | 1 | | ms |
| THERMAL SHUTDOWN COMPARATOR | | | | | | |
| T _{SHUT} | Thermal shutdown rising temperature | Temperature increasing | | 145 | | °C |
| T _{SHUT_HYS} | Thermal shutdown hysteresis | | | 15 | | °C |
| | Thermal shutdown rising deglitch | | Temperature increasing | 100 | | μs |
| | Thermal shutdown falling deglitch | | Temperature decreasing | 10 | | ms |
| THERMISTOR COMPARATOR | | | | | | |
| V _{LTF} | Cold temperature rising threshold | Charger suspended below this temperature | 72.5% | 73.5% | 74.5% | |
| V _{LTF_HYS} | Cold temperature hysteresis | | 0.2% | 0.4% | 0.6% | |
| V _{COOL} | Cool temperature rising threshold | Charger enabled, cuts back to I _{CHARGE} /8 below this temperature | 70.2% | 70.7% | 71.2% | |
| V _{COOL_HYS} | Cool temperature hysteresis | | 0.2% | 0.6% | 1.0% | |
| V _{WARM} | Warm temperature rising threshold | Charger cuts back to I _{CHARGE} /8 above this temperature | 47.5% | 48% | 48.5% | |
| V _{WARM_HYS} | Warm temperature hysteresis | | 1.0% | 1.2% | 1.4% | |
| V _{HTF} | Hot temperature rising threshold | Charger suspended above this temperature before initiating charge | 36.2% | 37% | 37.8% | |
| V _{TCO} | Cutoff temperature rising threshold | Charger suspended above this temperature during initiating charge | 33.7% | 34.4% | 35.1% | |
| | Deglitch time for temperature out-of-range detection | V _{TS} > V _{LTF} , or V _{TS} < V _{TCO} , or V _{TS} < V _{HTF} | | 400 | | ms |
| | Deglitch time for temperature in-invalid-range detection | V _{TS} < V _{LTF} - V _{LTF_HYS} or V _{TS} > V _{TCO} , or V _{TS} > V _{HTF} | | 20 | | ms |
| | Deglitch time for current reduction to I _{CHARGE} /8 due to warm or cool temperature | V _{TS} > V _{COOL} , or V _{TS} < V _{WARM} | | 25 | | ms |
| | Deglitch time to charge at I _{CHARGE} from I _{CHARGE} /8 when resuming from warm or cool temperatures | V _{TS} < V _{COOL} - V _{COOL_HYS} , or V _{TS} > V _{WARM} - V _{WARM_HYS} | | 25 | | ms |
| | Charge current due to warm or cool temperatures | V _{COOL} < V _{TS} < V _{LTF} , or V _{WARM} < V _{TS} < V _{HTF} , or V _{WARM} < V _{TS} < V _{TCO} | | I _{CHARGE} /8 | | |
| CHARGE OVERCURRENT COMPARATOR (CYCLE-BY-CYCLE) | | | | | | |
| V _{OC} | Charge overcurrent, falling threshold | Current rising, in nonsynchronous mode, measure on V _(SRP-SRN) , V _{SRP} < 2 V | | 45.5 | | mV |
| | | Current rising, as percentage of V _(IREG_CHG) , in synchronous mode, V _{SRP} > 2.2 V | | 160% | | |
| | Charge overcurrent, threshold floor | Minimum OCP threshold in synchronous mode, measure on V _(SRP-SRN) , V _{SRP} > 2.2 V | | 50 | | mV |
| | Charge overcurrent, threshold ceiling | Maximum OCP threshold in synchronous mode, measure on V _(SRP-SRN) , V _{SRP} > 2.2 V | | 180 | | mV |
| CHARGE UNDERCURRENT COMPARATOR (CYCLE-BY-CYCLE) | | | | | | |
| V _{ISYNSET} | Charge undercurrent, falling threshold | Switch from STNCH to NON-SYNCH, V _{SSP} > 2.2 V | 1 | 5 | 9 | mV |
| BATTERY SHORTED COMPARATOR (BATSHORT) | | | | | | |
| V _{BATSH} | BAT short falling threshold, forced non-syn mode | V _{SRP} falling | | 2 | | V |
| V _{BATSH_HYS} | BAT short rising hysteresis | | | 200 | | mV |
| V _{BATSH_DEG} | Deglitch on both edges | | | 1 | | μs |

Electrical Characteristics (continued)

5 V ≤ V_{VCC} ≤ 28 V, 0°C < T_J < 125°C, typical values are at T_A = 25°C, with respect to GND unless otherwise noted

| PARAMETER | | TEST CONDITIONS | MIN | TYP | MAX | UNIT |
|---|---|--|-------|------|-------|------|
| LOW CHARGE CURRENT COMPARATOR | | | | | | |
| V _{LC} | Average low charge current, falling threshold | Measure on V _(SRP-SRN) , forced into nonsynchronous mode | | 1.25 | | mV |
| V _{LC_HYS} | Low charge current, rising hysteresis | | | 1.25 | | mV |
| V _{LC_DEG} | Deglintch on both edges | | | 1 | | μs |
| VREF REGULATOR | | | | | | |
| V _{VREF_REG} | VREF regulator voltage | V _{VCC} > V _{UVLO} (0 – 35 mA Load) | 3.267 | 3.3 | 3.333 | V |
| I _{VREF_LIM} | VREF current limit | V _{VREF} = 0 V, V _{VCC} > V _{UVLO} | 35 | | | mA |
| REGN REGULATOR | | | | | | |
| V _{REGN_REG} | REGN regulator voltage | V _{VCC} > 10 V, CE = HIGH (0 – 40 mA Load) | 5.7 | 6 | 6.3 | V |
| I _{REGN_LIM} | REGN current limit | V _{REGN} = 0 V, V _{VCC} > V _{UVLO} | 40 | | | mA |
| SAFETY TIMER | | | | | | |
| T _{PRECHG} | Precharge safety timer range ⁽¹⁾ | Precharge time before fault occurs | 1440 | 1800 | 2160 | s |
| T _{CHARGE} | Internal fast-charge safety timer ⁽¹⁾ | | 4.25 | 5 | 5.75 | Hr |
| BATTERY DETECTION | | | | | | |
| t _{WAKE} | Wake timer | Max time charge is enabled | | 500 | | ms |
| I _{WAKE} | Wake current | R _{SENSE} = 10 mΩ | 50 | 125 | 200 | mA |
| t _{DISCHARGE} | Discharge timer | Max time discharge current is applied | | 1 | | s |
| I _{DISCHARGE} | Discharge current | | | 8 | | mA |
| I _{FAULT} | Fault current after a time-out fault | | | 2 | | mA |
| V _{WAKE} | Wake threshold (relative to V _{REG}) | Voltage on VFB to detect battery absent during wake | | 125 | | mV |
| V _{DISCH} | Discharge threshold | Voltage on VFB to detect battery absent during discharge | | 0.35 | | V |
| PWM HIGH-SIDE DRIVER (HIDRV) | | | | | | |
| R _{DS_HI_ON} | High-side driver (HSD) turnon resistance | V _{BTST} – V _{PH} = 5.5 V | | 3.3 | 6 | Ω |
| R _{DS_HI_OFF} | High-side driver turnoff resistance | V _{BTST} – V _{PH} = 5.5 V | | 1 | 1.3 | Ω |
| V _{BTST_REFRESH} | Bootstrap refresh comparator threshold voltage | V _{BTST} – V _{PH} when low-side refresh pulse is requested | 4 | 4.2 | | V |
| PWM LOW-SIDE DRIVER (LODRV) | | | | | | |
| R _{DS_LO_ON} | Low-side driver (LSD) turnon resistance | | | 4.1 | 7 | Ω |
| R _{DS_LO_OFF} | Low-side driver turnoff resistance | | | 1 | 1.4 | Ω |
| PWM DRIVERS TIMING | | | | | | |
| | Driver dead time | Dead time when switching between LSD and HSD, no load at LSD and HSD | | 30 | | ns |
| PWM OSCILLATOR | | | | | | |
| V _{RAMP_HEIGHT} | PWM ramp height | As percentage of VCC | | 7% | | |
| | PWM switching frequency ⁽¹⁾ | | 255 | 300 | 345 | kHz |
| INTERNAL SOFT START (Eight Steps to Regulation Current I_{CHARGE}) | | | | | | |
| | Soft-start steps | | | 8 | | step |
| | Soft-start step time | | | 1.6 | | ms |
| CHARGER SECTION POWER-UP SEQUENCING | | | | | | |
| | Charge-enable delay after power up | Delay from when CE = 1 to when the charger is allowed to turn on | | 1.5 | | s |
| LOGIC I/O PIN CHARACTERISTICS | | | | | | |
| V _{IN_LO} | CE input-low threshold voltage | | | | 0.8 | V |
| V _{IN_HI} | CE input-high threshold voltage | | 2.1 | | | V |
| V _{BIAS_CE} | CE input bias current | V = 3.3 V (CE has internal 1-MΩ pulldown resistor) | | | 6 | μA |
| V _{OUT_LO} | STAT, \overline{PG} output-low saturation voltage | Sink current = 5 mA | | | 0.5 | V |
| I _{OUT_HI} | Leakage current | V = 32 V | | | 1.2 | μA |

(1) Verified by design.

7.6 Typical Characteristics

Table 1. Table Of Graphs

| | FIGURE |
|---|----------|
| REF, REGN, and $\overline{\text{PG}}$ Power Up (CE = 1) | Figure 1 |
| Charge Enable | Figure 2 |
| Current Soft Start (CE = 1) | Figure 3 |
| Charge Disable | Figure 4 |
| Continuous Conduction Mode Switching Waveforms | Figure 5 |
| Cycle-by-Cycle Synchronous to Nonsynchronous | Figure 6 |
| Battery Insertion | Figure 7 |
| Battery-to-Ground Short Protection | Figure 8 |
| Efficiency vs Output Current | Figure 9 |

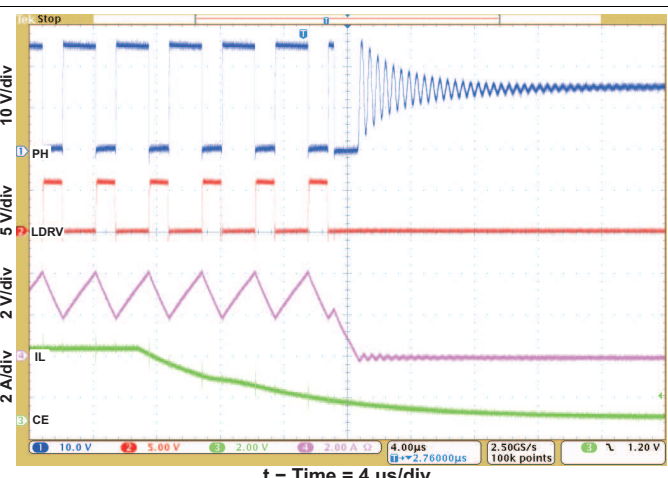
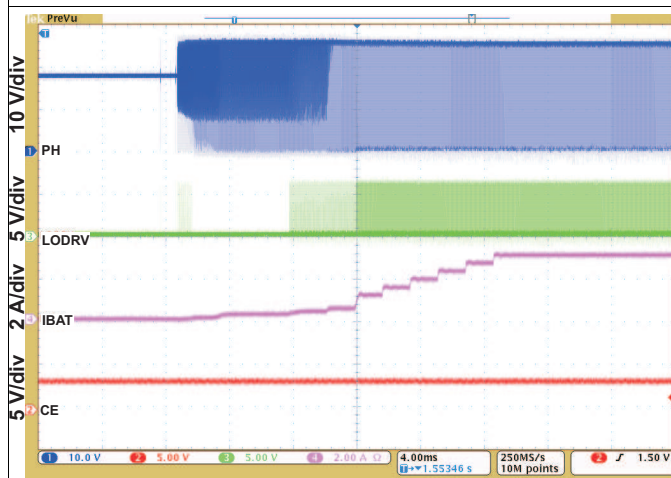
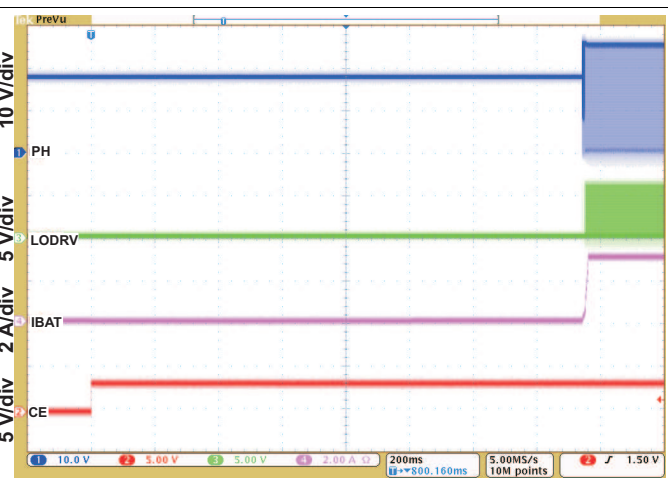
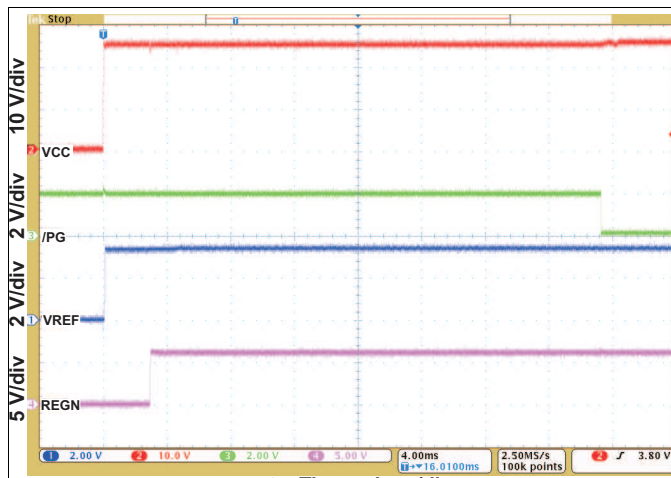

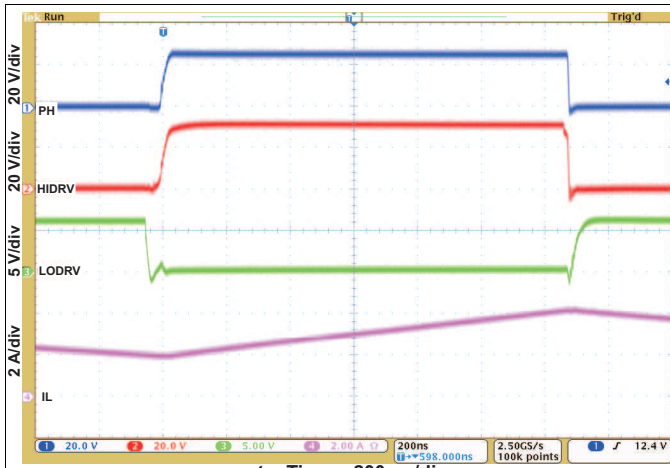

Figure 5. Continuous Conduction Mode Switching Waveform

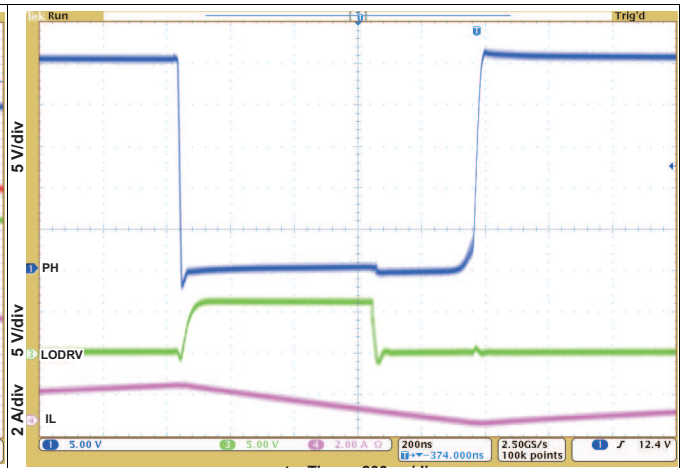

Figure 6. Cycle-by-Cycle Synchronous to Nonsynchronous

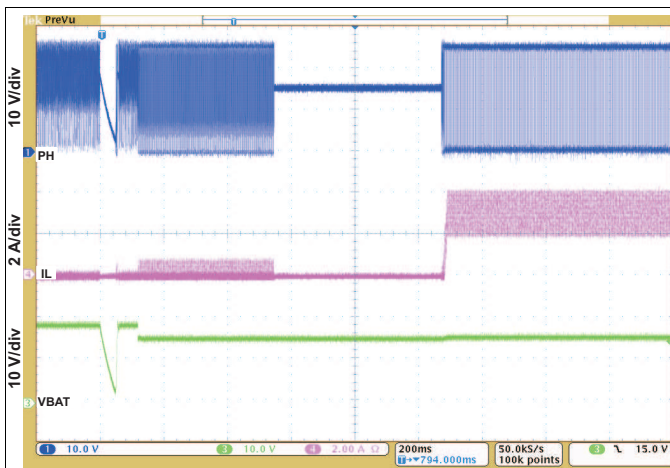

Figure 7. Battery Insertion

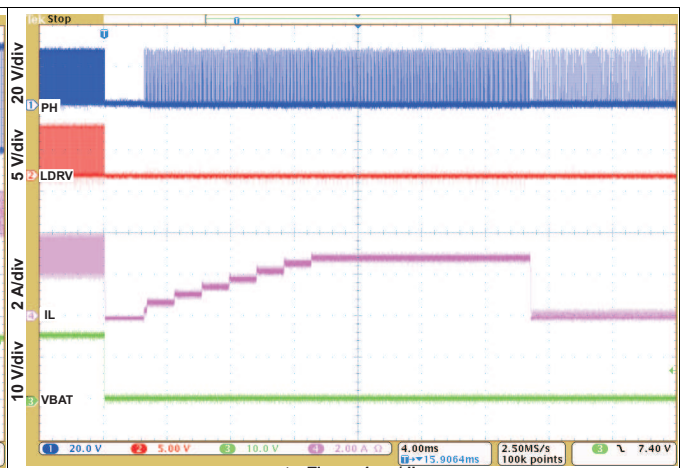

Figure 8. Battery-to-GND Short Protection

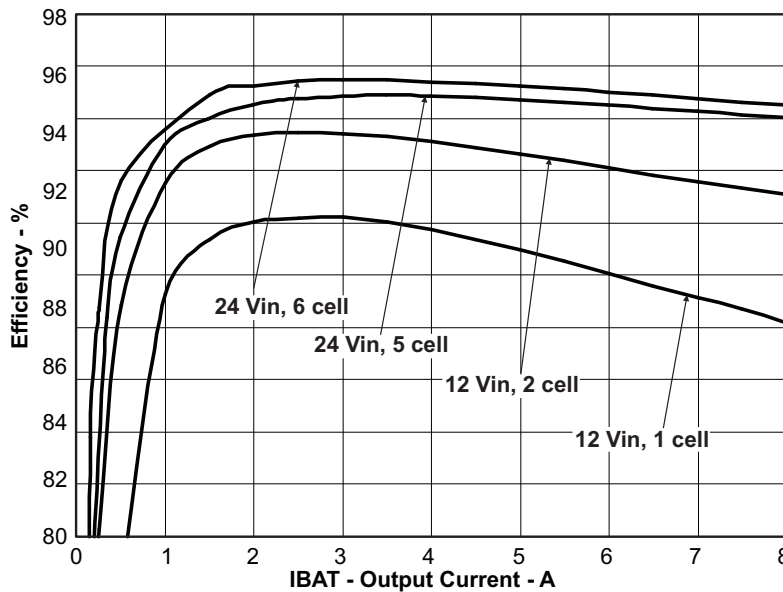

Figure 9. Efficiency vs Output Current

8 Detailed Description

8.1 Overview

The bq24620 device is a stand-alone, integrated lithium phosphate battery charger. The device employs a switched-mode synchronous buck PWM controller with constant switching frequency.

The bq24620 has a battery detect scheme that allows it to automatically detect the presence and absence of a battery. When the battery is detected, charging begins in one of three phases (depending upon battery voltage): precharge, constant current (fast-charge current regulation), and constant voltage (fast-charge voltage regulation). The device will terminate charging when the termination current threshold has been reached and will begin a recharge cycle when the battery voltage has dropped below the recharge threshold (V_{RECHG}). Constant (fastcharge) current and termination current can be configured through the ISET pin, allowing for flexibility in battery charging profile. During charging, the integrated fault monitors of the device, such as battery overvoltage protection, battery short detection (V_{BATSHD}), thermal shutdown (internal T_{SHUT} and TS pin), and input voltage protection (V_{ACOV} and V_{UVLO}), ensure battery safety.

The bq24620 has two status pins (STAT and \overline{PG}) to indicate the charging status and input voltage (AC adapter) status. These pins can be used to drive LEDs or communicate with a host processor. Additionally, the \overline{PG} pin can be used to drive external ACFET and BATFET.

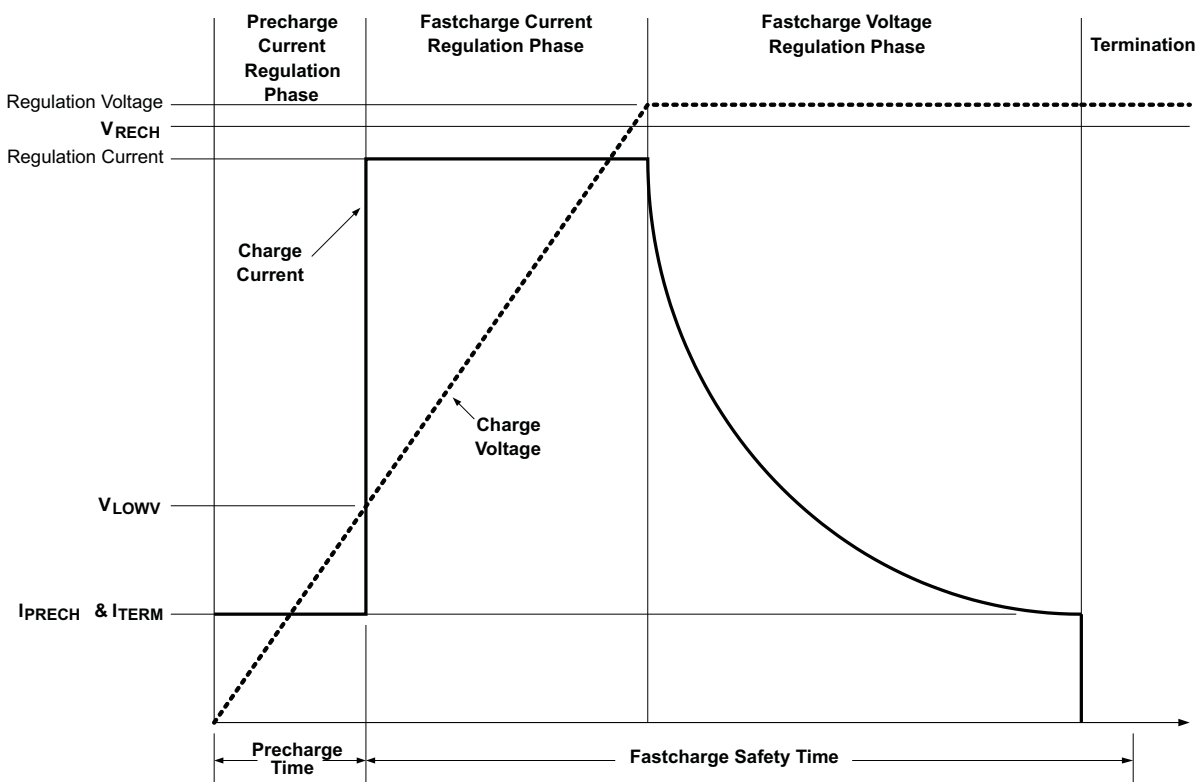
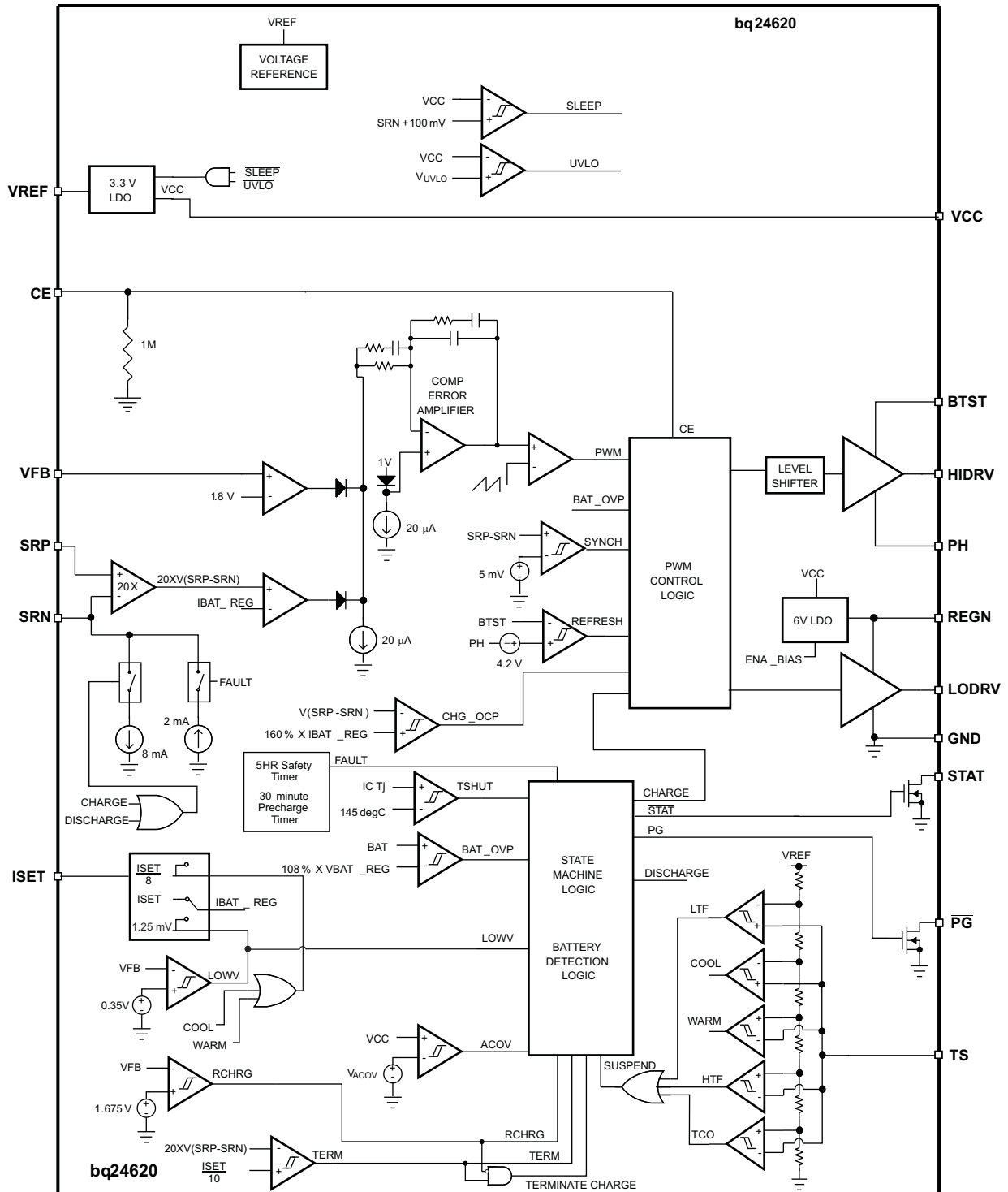

Figure 10. Typical Charging Profile

8.2 Functional Block Diagram



8.3 Feature Description

8.3.1 Battery Voltage Regulation

The bq24620 uses a high-accuracy voltage band gap and regulator for the charging voltage. The charge voltage is programmed through a resistor-divider from the battery to ground, with the midpoint tied to the VFB pin. The voltage at the VFB pin is regulated to 1.8 V, giving [Equation 1](#) for the regulation voltage:

$$V_{\text{BAT}} = 1.8 \text{ V} \times \left[1 + \frac{R2}{R1} \right]$$

where

- where R2 is connected from VFB to the battery and R1 is connected from VFB to GND. (1)

8.3.2 Battery Current Regulation

The ISET1 input sets the maximum charging current. Battery current is sensed by resistor R_{SR} connected between SRP and SRN. The full-scale differential voltage between SRP and SRN is 100 mV. Thus, for a 10-m Ω sense resistor, the maximum charging current is 10 A. [Equation 2](#) is for charge current:

$$I_{\text{CHARGE}} = \frac{V_{\text{ISET}}}{20 \times R_{\text{SR}}} \quad (2)$$

V_{ISET} , the input voltage range of ISET, is from 0 to 2 V. The SRP and SRN pins are used to sense voltage across R_{SR} with default value of 10 m Ω . However, resistors of other values can also be used. A larger sense resistor gives a larger sense voltage and a higher regulation accuracy, but at the expense of higher conduction loss.

8.3.3 Precharge

On power up, if the battery voltage is below the V_{LOWV} threshold, the bq24620 applies 125 mA to the battery. (1) The precharge feature is intended to revive deeply discharged cells. If the V_{LOWV} threshold is not reached within 30 minutes of initiating precharge, the charger turns off and a FAULT is indicated on the status pins.

8.3.4 Charge Termination, Recharge, and Safety Timer

The bq24620 monitors the charging current during the voltage regulation phase. Termination is detected while the voltage on the VFB pin is higher than the V_{RECH} threshold AND the charge current is less than the I_{TERM} threshold, which is 1/10th of programmed charge current, as calculated in [Equation 3](#):

$$I_{\text{TERM}} = \frac{V_{\text{ISET}}}{200 \times R_{\text{SR}}} \quad (3)$$

As a safety backup, the bq24620 also provides an internal 5-hour charge timer for fast charge.

A new charge cycle is initiated when one of the following conditions occurs:

- The battery voltage falls below the recharge threshold.
- A power-on reset (POR) event occurs.
- CE is toggled.

8.3.5 Power Up

The bq24620 uses a SLEEP comparator to determine the source of power on the VCC pin, because VCC can be supplied either from the battery or the adapter. If the VCC voltage is greater than the SRN voltage, the bq24620 enables ACFET and disables BATFET. If all other conditions are met for charging, the bq24620 then attempts to charge the battery (see [Enable and Disable Charging](#)). If the SRN voltage is greater than VCC, indicating that the battery is the power source, bq24620 enters a low-quiescent-current (<15 μA) SLEEP mode to minimize current drain from the battery.

If VCC is below the UVLO threshold, the device is disabled.

(1) 125 mA (assuming a 10-m Ω sense resistor. 1.25 mV is regulated across SRP-SRN, regardless of the value of the sense resistor.)

Feature Description (continued)

8.3.6 Enable and Disable Charging

The following conditions must be valid before charge is enabled:

- CE is HIGH.
- The device is not in VCCLOWV mode.
- The device is not in SLEEP mode (that is, $VCC > SRN$).
- The VCC voltage is lower than the ac overvoltage threshold ($VCC < V_{ACOV}$).
- 30-ms delay is complete after initial power up.
- The REGN LDO and VREF LDO voltages are at the correct levels.
- Thermal shutdown (TSHUT) is not valid.
- TS fault is not detected.

Any of the following conditions stops ongoing charging:

- CE is LOW.
- Adapter is removed, causing the device to enter VCCLOWV or SLEEP mode.
- Adapter voltage is less than 100 mV above battery.
- Adapter is over voltage.
- The REGN or VREF LDOs are overloaded.
- TSHUT IC temperature threshold is reached (145°C on rising edge with 15°C hysteresis).
- TS voltage goes out of range, indicating the battery temperature is too hot or too cold.
- Safety timer times out.

8.3.7 Automatic Internal Soft-Start Charger Current

The charger automatically soft-starts the charger regulation current every time the charger goes into fast-charge to ensure there is no overshoot or stress on the output capacitors or the power converter. The soft-start consists of stepping up the charge regulation current into eight evenly divided steps up to the programmed charge current. Each step lasts around 1.6 ms, for a typical rise time of 12.8 ms. No external components are needed for this function.

8.3.8 Converter Operation

The synchronous buck PWM converter uses a fixed-frequency voltage mode with a feed-forward control scheme. A type-III compensation network allows using ceramic capacitors at the output of the converter. The compensation input stage is connected internally between the feedback output (FBO) and the error amplifier input (EAI). The feedback compensation stage is connected between the error amplifier input (EAI) and error amplifier output (EAO). The LC output filter is selected to give a resonant frequency of 10 kHz to 15 kHz for bq24620, where the resonant frequency, f_o , is given by:

$$f_o = \frac{1}{2\pi\sqrt{L_o C_o}} \quad (4)$$

An internal sawtooth ramp is compared to the internal EAO error control signal to vary the duty cycle of the converter. The ramp height is 7% of the input adapter voltage, making it always directly proportional to the input adapter voltage. This cancels out any loop gain variation due to a change in input voltage, and simplifies the loop compensation. The ramp is offset by 300 mV in order to allow zero-percent duty cycle when the EAO signal is below the ramp. The EAO signal is also allowed to exceed the sawtooth ramp signal in order to get a 100% duty-cycle PWM request. Internal gate-drive logic allows achieving 99.95% duty cycle while ensuring the N-channel upper device always has enough voltage to stay fully on. If the BTST pin to PH pin voltage falls below 4.2 V for more than three cycles, then the high-side N-channel power MOSFET is turned off and the low-side N-channel power MOSFET is turned on to pull the PH node down and recharge the BTST capacitor. Then the high-side driver returns to 100% duty-cycle operation until the (BTST–PH) voltage is detected to fall low again due to leakage current discharging the BTST capacitor below 4.2 V, and the reset pulse is reissued.

The fixed-frequency oscillator keeps tight control of the switching frequency under all conditions of input voltage, battery voltage, charge current, and temperature, simplifying output filter design and keeping it out of the audible noise region. Also see [Application and Implementation](#) for how to select the inductor, capacitor, and MOSFET.

Feature Description (continued)

8.3.9 Synchronous and Nonsynchronous Operation

The charger operates in synchronous mode when the SRP-SRN voltage is above 5 mV (0.5-A inductor current for a 10-m Ω sense resistor). During synchronous mode, the internal gate-drive logic ensures there is break-before-make complementary switching to prevent shoot-through currents. During the 30-ns dead time where both FETs are off, the body diode of the low-side power MOSFET conducts the inductor current. Having the low-side FET turn on keeps the power dissipation low, and allows safely charging at high currents. During synchronous mode, the inductor current is always flowing and the converter operates in continuous conduction mode (CCM), creating a fixed two-pole system.

The charger operates in nonsynchronous mode when the SRP-SRN voltage is below 5 mV (0.5-A inductor current for a 10-m Ω sense resistor). The charger is forced into nonsynchronous mode when the battery voltage is lower than 2 V or when the average SRP-SRN voltage is lower than 1.25 mV.

During nonsynchronous operation, the body diode of the low-side MOSFET can conduct the positive inductor current after the high-side N-channel power MOSFET turns off. When the load current decreases and the inductor current drops to zero, the body diode is naturally turned off and the inductor current becomes discontinuous. This mode is called discontinuous conduction mode (DCM). During DCM, the low-side N-channel power MOSFET turns on for around 80 ns when the bootstrap capacitor voltage drops below 4.2 V; then the low-side power MOSFET turns off and stays off until the beginning of the next cycle, where the high-side power MOSFET is turned on again. The 80-ns low-side MOSFET on-time is required to ensure the bootstrap capacitor is always recharged and able to keep the high-side power MOSFET on during the next cycle. This is important for battery chargers, where unlike regular DC-DC converters, there is a battery load that maintains a voltage and can both source and sink current. The 80-ns low-side pulse pulls the PH node (connection between high- and low-side MOSFETs) down, allowing the bootstrap capacitor to recharge up to the REGN LDO value. After the 80 ns, the low-side MOSFET is kept off to prevent negative inductor current from occurring.

At very low currents during nonsynchronous operation, there may be a small amount of negative inductor current during the 80-ns recharge pulse. The charge must be low enough to be absorbed by the input capacitance. Whenever the converter goes into zero-percent duty cycle, the high-side MOSFET does not turn on, and the low-side MOSFET does not turn on (only 80-ns recharge pulse) either, and there is almost no discharge from the battery.

During the DCM mode, the loop response automatically changes and has a single-pole system at which the pole is proportional to the load current, because the converter does not sink current, and only the load provides a current sink. This means at very low currents the loop response is slower, as there is less sinking current available to discharge the output voltage.

8.3.10 Cycle-by-Cycle Charge Undercurrent

If the SRP-SRN voltage decreases below 5 mV (the charger is also forced into nonsynchronous mode when the average SRP-SRN voltage is lower than 1.25 mV), the low-side FET is turned off for the remainder of the switching cycle to prevent negative inductor current. During DCM, the low-side FET only turns on for around 80 ns when the bootstrap capacitor voltage drops below 4.2 V to provide refresh charge for the bootstrap capacitor. This is important to prevent negative inductor current from causing a boost effect in which the input voltage increases as power is transferred from the battery to the input capacitors, which leads to an overvoltage stress on the VCC node and potentially causes damage to the system.

8.3.11 Input Overvoltage Protection (ACOV)

ACOV provides protection to prevent system damage due to high input voltage. Once the adapter voltage reaches the ACOV threshold, charge is disabled and the battery is switched to the system instead of the adapter.

8.3.12 Input Undervoltage Lockout (UVLO)

The system must have a minimum VCC voltage to allow proper operation. This VCC voltage could come from either input the adapter or the battery, if a conduction path exists from the battery to VCC through the high-side NMOS body diode. When VCC is below the UVLO threshold, all circuits in the IC are disabled.

Feature Description (continued)

8.3.13 Battery Overvoltage Protection

The converter does not allow the high-side FET to turn on until the BAT voltage goes below 105% of the regulation voltage. This allows one-cycle response to an overvoltage condition, such as occurs when the load is removed or the battery is disconnected. An 8-mA current sink from SRP/SRN to PGND is on only during charge and allows discharging the stored output inductor energy that is transferred to the output capacitors. BATOVP also suspends the safety timer.

8.3.14 Cycle-by-Cycle Charge Overcurrent Protection

The charger has a secondary cycle-to-cycle overcurrent protection. The charger monitors the charge current, and prevents the current from exceeding 160% of the programmed charge current. The high-side gate drive turns off when the overcurrent is detected, and automatically resumes when the current falls below the overcurrent threshold.

8.3.15 Thermal Shutdown Protection

The QFN package has low thermal impedance, which provides good thermal conduction from the silicon to the ambient, to keep junction temperatures low. As an added level of protection, the charger converter turns off and self-protects whenever the junction temperature exceeds the TSHUT threshold of 145°C. The charger stays off until the junction temperature falls below 130°C. Then the charger soft-starts again if all other enable-charge conditions are valid. Thermal shutdown also suspends the safety timer.

8.3.16 Temperature Qualification

The controller continuously monitors battery temperature by measuring the voltage between the TS pin and GND. A negative temperature coefficient thermistor (NTC) and an external voltage divider typically develop this voltage. The controller compares this voltage against its internal thresholds to determine if charging is allowed. To initiate a charge cycle, the battery temperature must be within the V_{LTF} to V_{HTF} thresholds. If battery temperature is outside of this range, the controller suspends charge and the safety timer and waits until the battery temperature is within the V_{LTF} to V_{HTF} range. During the charge cycle, the battery temperature must be within the V_{LTF} to V_{TCO} thresholds. If the battery temperature is outside of this range, the controller suspends charge and the safety timer and waits until the battery temperature is within the V_{LTF} to V_{HTF} range. If the battery temperature is between the V_{LTF} and V_{COOL} thresholds or between the V_{HTF} and V_{WARM} thresholds, charge is automatically reduced to $I_{CHARGE}/8$. To avoid early termination during COOL/WARM condition, set $I_{TERM} \leq I_{CHARGE}/10$. The controller suspends charge by turning off the PWM charge FETs. [Figure 11](#) and [Figure 12](#) summarize the operation.

Feature Description (continued)

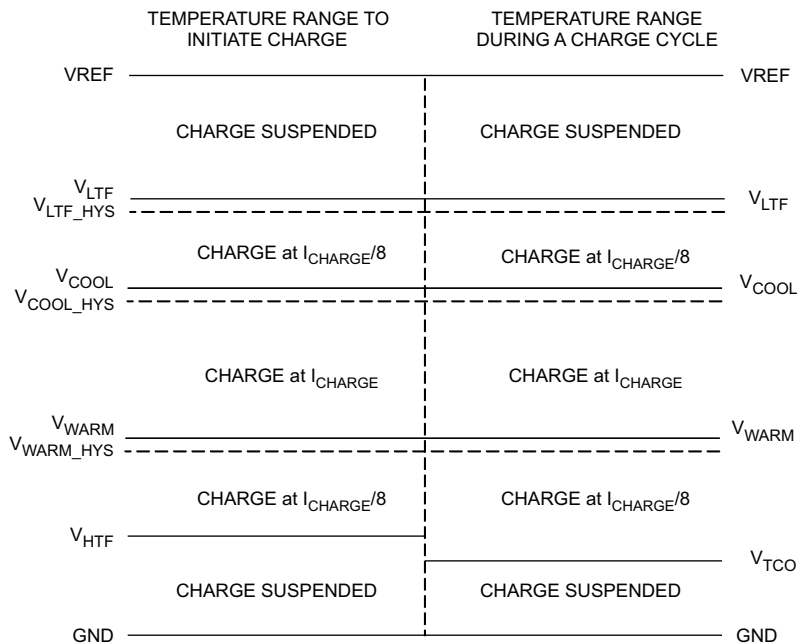

Figure 11. TS, Thermistor Sense Thresholds

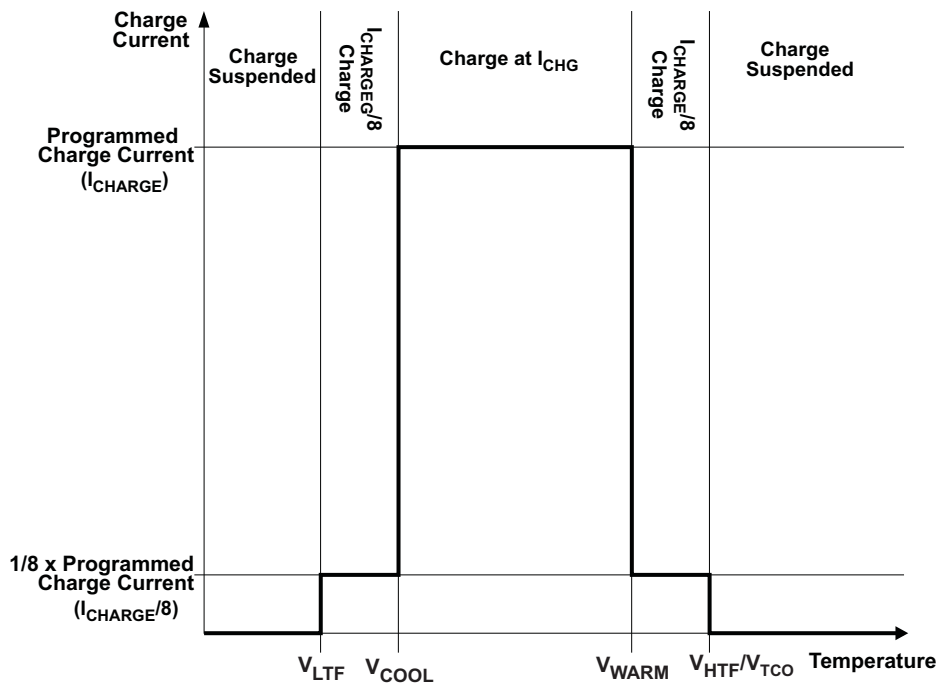

Figure 12. Typical Charge Current vs Temperature Profile

Assuming a 103AT NTC thermistor on the battery pack as shown in Figure 17, the values of RT1 and RT2 can be determined by using Equation 5 and Equation 6:

Feature Description (continued)

$$RT2 = \frac{V_{VREF} \times R_{TH_{COOL}} \times R_{TH_{WARM}} \times \left(\frac{1}{V_{COOL}} - \frac{1}{V_{WARM}} \right)}{R_{TH_{WARM}} \times \left(\frac{V_{VREF}}{V_{WARM}} - 1 \right) - R_{TH_{COOL}} \times \left(\frac{V_{VREF}}{V_{COOL}} - 1 \right)} \quad (5)$$

$$RT1 = \frac{\frac{V_{VREF}}{V_{COOL}} - 1}{\frac{1}{RT2} + \frac{1}{R_{TH_{COOL}}}} \quad (6)$$

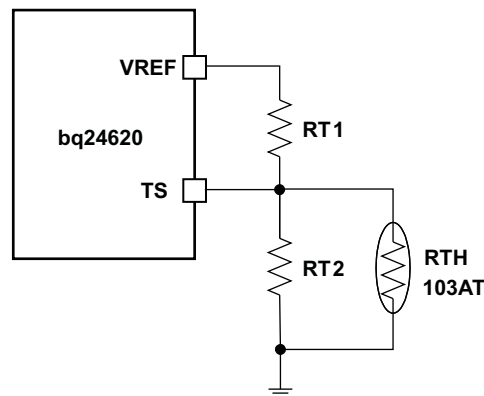
Figure 13. TS Resistor Network

For example, a 103AT NTC thermistor is used to monitor the battery pack temperature. Select $T_{COOL} = 0^{\circ}\text{C}$, $T_{WARM} = 60^{\circ}\text{C}$. From the calculation and selecting a standard 5% resistor value, we can get $RT1 = 2.2\text{ k}\Omega$, $RT2 = 6.8\text{ k}\Omega$, and T_{COLD} is -17°C (target -20°C); T_{HOT} is 77°C (target 75°C), and $T_{CUT-OFF}$ is 86°C (target 80°C). A small RC filter is suggested to protect the TS pin from system-level ESD.

8.3.17 Timer Fault Recovery

The bq24620 provides a recovery method to deal with timer fault conditions. The following summarizes this method:

Condition 1: The battery voltage is above the recharge threshold and a time-out fault occurs.

Recovery Method: The timer fault clears when the battery voltage falls below the recharge threshold, and battery detection begins. Taking CE low, or a POR condition, also clears the fault.

Condition 2: The battery voltage is below the RECHARGE threshold and a time-out fault occurs.

Recovery Method: Under this scenario, the bq24620 applies the IFAULT current to the battery. This small current is used to detect a battery removal condition and remains on as long as the battery voltage stays below the recharge threshold. If the battery voltage goes above the recharge threshold, the bq24620 disables the fault current and executes the recovery method described in Condition 1. Taking CE low, or a POR condition, also clears the fault.

8.3.18 $\overline{\text{PG}}$ Output

The open-drain $\overline{\text{PG}}$ (power good) indicates whether the VCC voltage is valid or not. The open-drain FET turns on whenever the bq24620 has a valid VCC input (not in UVLO or ACOV or SLEEP mode). The PG pin can be used to drive an LED or communicate with the host processor.

Feature Description (continued)

8.3.19 CE (Charge Enable)

The CE digital input is used to disable or enable the charge process. A high-level signal on this pin enables charge, provided all the other conditions for charge are met (see [Enable and Disable Charging](#)). A high-to-low transition on this pin also resets all timers and fault conditions. There is an internal 1-M Ω pulldown resistor on the CE pin, so if CE is floated, the charge does not turn on.

8.3.20 Charge Status Outputs

The open-drain STAT outputs indicate various charger operations as shown in [Table 2](#). These status pins can be used to drive LEDs or communicate with the host processor. OFF indicates that the open-drain transistor is turned off.

Table 2. Stat Pin Definition For Bq24620

| CHARGE STATE | STAT |
|---|----------------|
| Charge in progress | ON |
| Charge complete ($\overline{\text{PG}} = \text{LOW}$) | OFF |
| Sleep mode ($\overline{\text{PG}} = \text{HIGH}$) | OFF |
| Charge suspend, timer fault, ACOV, battery absent | BLINK (0.5 Hz) |

8.3.21 Battery Detection

For applications with removable battery packs, the bq24620 provides a battery-absent detection scheme to reliably detect insertion or removal of battery packs. CE must be HIGH to enable battery detection function.

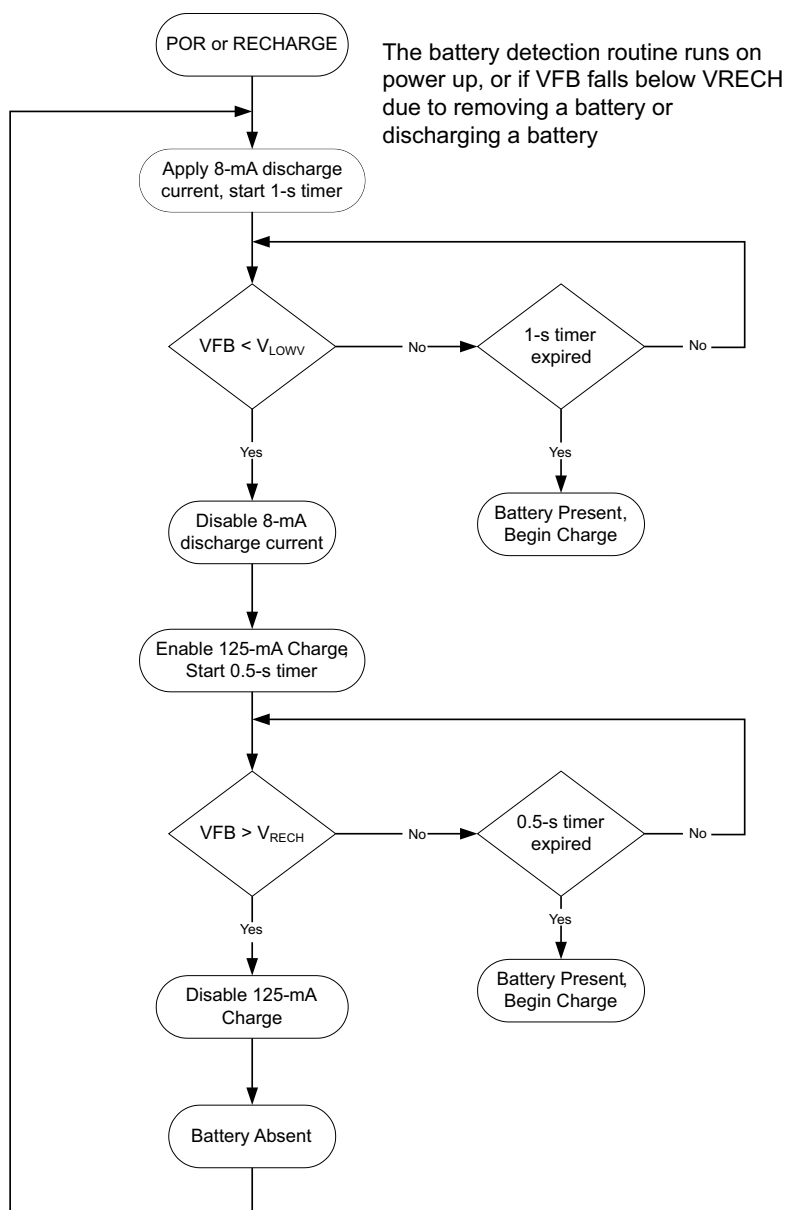

Figure 14. Battery Detection Flow Chart

Once the device has powered up, an 8-mA discharge current is applied to the SRN terminal. If the battery voltage falls below the LOWV threshold within 1 second, the discharge source is turned off, and the charger is turned on at low charge current (125 mA). If the battery voltage rises above the recharge threshold within 500 ms, no battery is present and the cycle restarts. If either the 500-ms or 1-second timer times out before the respective thresholds are hit, a battery is detected and a charge cycle is initiated. See [Maximum Output Capacitance](#) for more information.

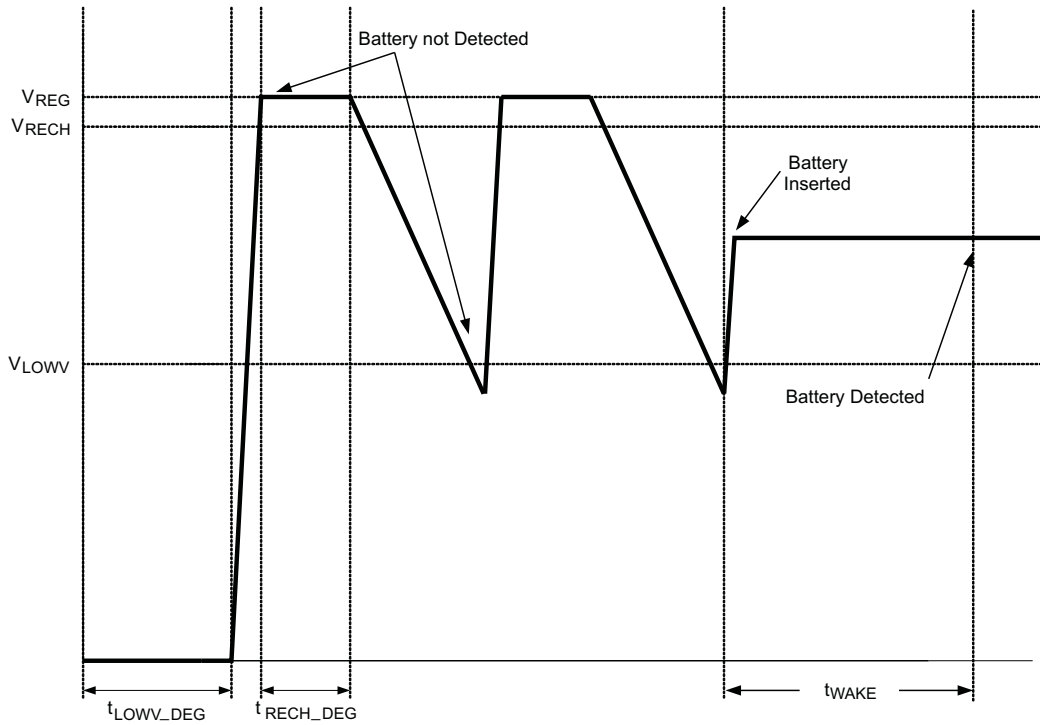

Figure 15. Battery-Detect Timing Diagram

8.4 Device Functional Modes

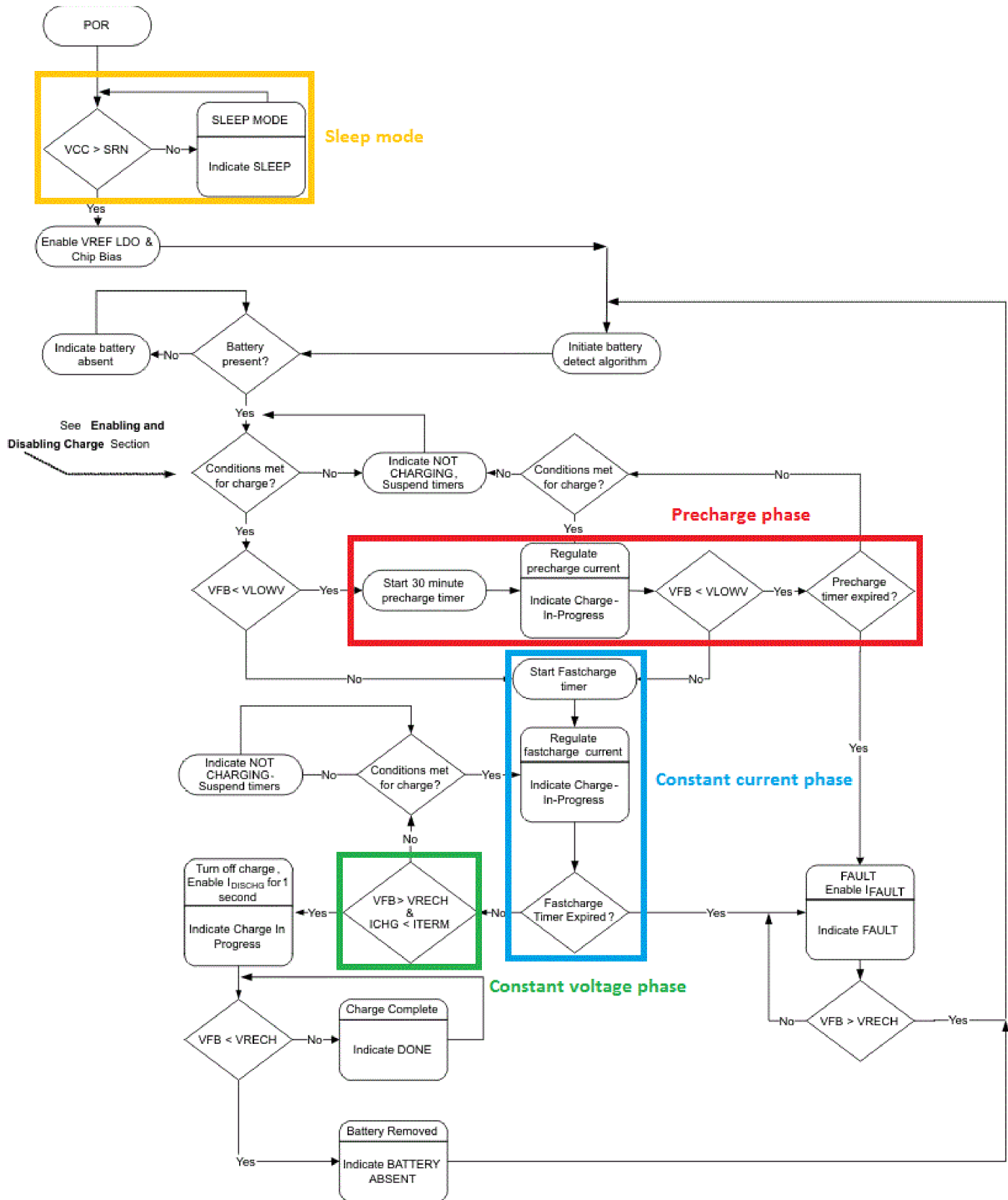

Figure 16. Device Operational Flow Chart

9 Application and Implementation

NOTE

Information in the following applications sections is not part of the TI component specification, and TI does not warrant its accuracy or completeness. TI's customers are responsible for determining suitability of components for their purposes. Customers should validate and test their design implementation to confirm system functionality.

9.1 Application Information

The bq24620 battery charger is ideal for high current charging (up to 10 A) and can charge battery packs consisting of single cells or multiple cells in series. The bq24620EVM evaluation module is a complete charge module for evaluating the bq24620. The application curves were taken using the bq24620EVM. Refer to the EVM user's guide (SLUU410) for EVM information.

9.2 Typical Application

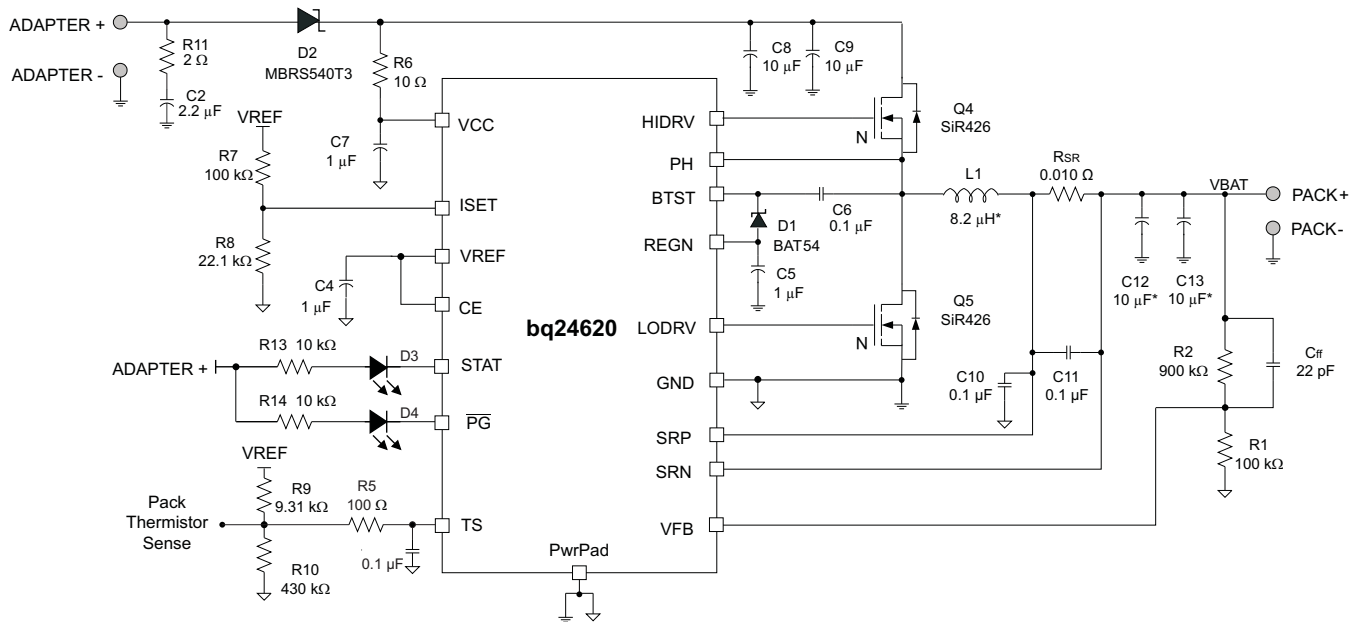

NOTE: VIN = 28 V, BAT = 5-cell Li-Phosphate, I_{charge} = 3 A, I_{precharge} = 0.125 A, I_{term} = 0.3 A

Figure 17. Typical System Schematic

9.2.1 Design Requirements

For this design example, use the parameters listed in Table 3 as the input parameters.

Table 3. Design Parameters

| DESIGN PARAMETER | EXAMPLE VALUE |
|--|----------------|
| AC adapter voltage (VIN) | 28 V |
| Battery charge voltage (number of cells in series) | 18 V (5 cells) |
| Battery charge current (during constant current phase) | 3 A |
| Precharge current | 0.125 A |
| Termination current | 0.3 A |

9.2.2 Detailed Design Procedure

9.2.2.1 Inductor Selection

The bq24620 has a 300-kHz switching frequency to allow the use of small inductor and capacitor values. Inductor saturation current must be higher than the charging current (I_{CHARGE}) plus half the ripple current (I_{RIPPLE}):

$$I_{\text{SAT}} \geq I_{\text{CHG}} + (1/2) I_{\text{RIPPLE}} \quad (7)$$

The inductor ripple current depends on input voltage (V_{IN}), duty cycle ($D = V_{\text{OUT}}/V_{\text{IN}}$), switching frequency (f_{S}) and inductance (L):

$$I_{\text{RIPPLE}} = \frac{V_{\text{IN}} \times D \times (1 - D)}{f_{\text{S}} \times L} \quad (8)$$

The maximum inductor ripple current happens with $D = 0.5$. For example, the battery-charging voltage range is from 2.8 V to 14.4 V for a four-cell battery pack. For 20-V adapter voltage, 10-V battery voltage gives the maximum inductor ripple current.

Usually, inductor ripple is designed in the range of 20%–40% of maximum charging current as a trade-off between inductor size and efficiency for a practical design.

The bq24620 has cycle-by-cycle charge undercurrent protection (UCP) by monitoring the charging-current sensing resistor to prevent negative inductor current. The typical UCP threshold is 5 mV falling edge, corresponding to 0.5-A falling edge for a 10-m Ω charging-current-sensing resistor.

9.2.2.2 Input Capacitor

The input capacitor must have enough ripple current rating to absorb input switching-ripple current. The worst-case RMS ripple current is half of the charging current when duty cycle is 0.5. If the converter does not operate at 50% duty cycle, then the worst-case capacitor RMS current I_{CIN} occurs where the duty cycle is closest to 50% and can be estimated by the following equation:

$$I_{\text{CIN}} = I_{\text{CHG}} \times \sqrt{D \times (1-D)} \quad (9)$$

A low-ESR ceramic capacitor such as X7R or X5R is preferred for the input-decoupling capacitor and must be placed as close as possible to the drain of the high-side MOSFET and source of the low-side MOSFET. The voltage rating of the capacitor must be higher than the normal input voltage level. A 25-V rating or higher capacitor is preferred for 20-V input voltage. A 20- μF capacitor is suggested for typical of 3-A to 4-A charging current.

9.2.2.3 Output Capacitor

The output capacitor also must have enough ripple current rating to absorb the output switching-ripple current. The output capacitor RMS current I_{COUT} is given:

$$I_{\text{COUT}} = \frac{I_{\text{RIPPLE}}}{2 \times \sqrt{3}} \approx 0.29 \times I_{\text{RIPPLE}} \quad (10)$$

The output capacitor voltage ripple can be calculated as follows:

$$\Delta V_{\text{O}} = \frac{1}{8LCf_{\text{S}}^2} \left(V_{\text{BAT}} - \frac{V_{\text{BAT}}^2}{V_{\text{IN}}} \right) \quad (11)$$

At certain input and output voltage and switching frequency, the voltage ripple can be reduced by increasing the output filter LC.

The bq24620 has an internal loop compensator. To get good loop stability, the resonant frequency of the output inductor and output capacitor must be designed from 10 kHz to 15 kHz. The preferred ceramic capacitor is 25 V, X7R, or X5R for 4-cell applications.

9.2.2.4 Power MOSFET Selection

Two external N-channel MOSFETs are used for a synchronous switching battery charger. The gate drivers are internally integrated into the IC with 6 V of gate drive voltage. 30-V or higher voltage rating MOSFETs are preferred for 20-V input voltage, and 40-V MOSFETs are preferred for 20-V to 28-V input voltage.

Figure-of-merit (FOM) is usually used for selecting the proper MOSFET, based on a tradeoff between the conduction loss and switching loss. For the top-side MOSFET, FOM is defined as the product of the MOSFET ON-resistance, $r_{DS(on)}$, and the gate-to-drain charge, Q_{GD} . For the bottom-side MOSFET, FOM is defined as the product of the MOSFET ON-resistance, $r_{DS(on)}$, and the total gate charge, Q_G .

$$FOM_{top} = R_{DS(on)} \times Q_{GD} \quad FOM_{bottom} = R_{DS(on)} \times Q_G \quad (12)$$

The lower the FOM value, the lower the total power loss. Usually lower $r_{DS(on)}$ has higher cost with the same package size.

The top-side MOSFET loss includes conduction loss and switching loss. It is a function of duty cycle ($D = V_{OUT}/V_{IN}$), charging current (I_{CHARGE}), MOSFET ON-resistance $r_{DS(on)}$, input voltage (V_{IN}), switching frequency (f_s), turnon time (t_{on}), and turnoff time (t_{off}):

$$P_{top} = D \times I_{CHG}^2 \times R_{DS(on)} + \frac{1}{2} \times V_{IN} \times I_{CHG} \times (t_{on} + t_{off}) \times f_s \quad (13)$$

The first item represents the conduction loss. Usually MOSFET $r_{DS(on)}$ increases by 50% with 100°C junction temperature rise. The second term represents the switching loss. The MOSFET turnon and turnoff times are given by:

$$t_{on} = \frac{Q_{SW}}{I_{on}}, \quad t_{off} = \frac{Q_{SW}}{I_{off}} \quad (14)$$

where Q_{SW} is the switching charge, I_{on} is the turnon gate-driving current, and I_{off} is the turnoff gate-driving current. If the switching charge is not given in the MOSFET data sheet, it can be estimated by gate-to-drain charge (Q_{GD}) and gate-to-source charge (Q_{GS}):

$$Q_{SW} = Q_{GD} + \frac{1}{2} \times Q_{GS} \quad (15)$$

Total gate-driving current can be estimated by the REGN voltage (V_{REGN}), MOSFET plateau voltage (V_{plt}), total turnon gate resistance (R_{on}), and turnoff gate resistance R_{off} of the gate driver:

$$I_{on} = \frac{V_{REGN} - V_{plt}}{R_{on}}, \quad I_{off} = \frac{V_{plt}}{R_{off}} \quad (16)$$

The conduction loss of the bottom-side MOSFET is calculated with the following equation when it operates in synchronous continuous conduction mode:

$$P_{bottom} = (1 - D) \times I_{CHG}^2 \times R_{DS(on)} \quad (17)$$

If the SRP–SRN voltage decreases below 5 mV (the charger is also forced into nonsynchronous mode when the average SRP–SRN voltage is lower than 1.25 mV), the low-side FET is turned off for the remainder of the switching cycle to prevent negative inductor current.

As a result, all the freewheeling current goes through the body diode of the bottom-side MOSFET. The maximum charging current in nonsynchronous mode can be up to 0.9 A (0.5 A typical) for a 10-mΩ charging-current-sensing resistor, considering IC tolerance. Choose the bottom-side MOSFET with either an internal Schottky or body diode capable of carrying the maximum nonsynchronous mode charging current.

MOSFET gate-driver power loss contributes to the dominant losses on controller IC when the buck converter is switching. Choosing a MOSFET with a small Q_{g_total} reduces the IC power loss to avoid thermal shutdown.

$$P_{ICLoss_driver} = V_{IN} \cdot Q_{g_total} \cdot f_s$$

where

- Q_{g_total} is the total gate charge for both upper and lower MOSFETs at 6-V V_{REGN} (18)

The VREF load current is another component of the VCC input current (do not overload VREF), where total IC loss can be described by following equations:

$$P_{VREF} = (V_{IN} - V_{VREF}) \cdot I_{VREF}$$

$$P_{ICLOSS} = P_{ICLOSS_driver} + P_{VREF} + P_{Quiescent} \quad (19)$$

9.2.2.5 Input Filter Design

During adapter hot plug-in, the parasitic inductance and input capacitor from the adapter cable form a second-order system. The voltage spike at the VCC pin may be beyond the IC maximum voltage rating and damage the IC. The input filter must be carefully designed and tested to prevent an overvoltage event on VCC pin.

There are several methods to damping or limiting the overvoltage spike during adapter hot plug-in. An electrolytic capacitor with high ESR as an input capacitor can damp the overvoltage spike well below the IC maximum pin-voltage rating. A high-current-capability TVS Zener diode can also limit the overvoltage level to an IC-safe level. However, these two solutions may not have low cost or small size.

A cost-effective and small-size solution is shown in [Figure 18](#). R1 and C1 comprise a damping RC network to damp the hot plug-in oscillation. As a result, the overvoltage spike is limited to a safe level. D1 is used for reverse voltage protection for the VCC pin (it can be the input Schottky diode or the body diode of the input ACFET). C2 is a VCC pin-decoupling capacitor, and it must be placed as close as possible to the VCC pin. R2 and C2 form a damping RC network to further protect the IC from high-dv/dt and high-voltage spikes. The C2 value must be less than the C1 value so R1 can be dominant over the ESR of C1 to get enough damping effect for hot plug-in. R1 and R2 packages must be sized to handle the inrush-current power loss according to the resistor manufacturer's data sheet. The filter component values always must be verified with the real application, and minor adjustments may be needed to fit in the real application circuit.

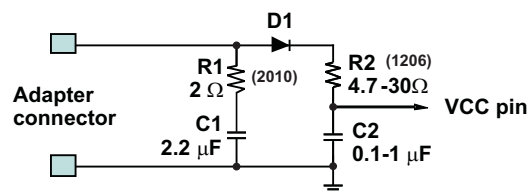

Figure 18. Input Filter

9.2.2.6 Inductor, Capacitor, and Sense Resistor Selection Guidelines

The bq24620 provides internal loop compensation. With this scheme, best stability occurs when the LC resonant frequency, f_o , is approximately 10 kHz to 15 kHz per [Equation 20](#):

$$f_o = \frac{1}{2\pi\sqrt{L_o C_o}} \quad (20)$$

[Table 4](#) provides a summary of typical LC components for various charge currents

Table 4. Typical Inductor, Capacitor, and Sense Resistor Values as a Function of Charge Current

| CHARGE CURRENT | 2 A | 4 A | 6 A | 8 A | 10 A |
|------------------------|---------------|---------------|---------------|---------------|---------------|
| Output inductor L_o | 8.2 μ H | 8.2 μ H | 5.6 μ H | 4.7 μ H | 4.7 μ H |
| Output capacitor C_o | 20 μ F | 20 μ F | 20 μ F | 40 μ F | 40 μ F |
| Sense resistor | 10 m Ω | 10 m Ω | 10 m Ω | 10 m Ω | 10 m Ω |

Table 5. Component List for Typical System Circuit of Figure 17

| PART DESIGNATOR | QTY | DESCRIPTION |
|------------------|-----|---|
| Q4, Q5 | 2 | N-channel MOSFET, 40 V, 30 A, PowerPAK SO-8, Vishay-Siliconix, SiR426DN |
| D1 | 1 | Diode, dual Schottky, 30 V, 200 mA, SOT23, Fairchild, BAT54C |
| D2 | 1 | Schottky diode, 40 V, 5 A, SMC, ON Semiconductor, MBR540T3 |
| R _{SR} | 2 | Sense resistor, 10 mΩ, 1%, 1 W, 2010, Vishay-Dale, WSL2010R0100F |
| L1 | 1 | Inductor, 6.8 μH, 5.5 A, Vishay-Dale, IHLP2525CZ |
| C8, C9, C12, C13 | 4 | Capacitor, ceramic, 10 μF, 35 V, 10%, X7R |
| C2 | 1 | Capacitor, ceramic, 2.2 μF, 50 V, 10%, X7R |
| C4, C5 | 2 | Capacitor, ceramic, 1 μF, 16 V, 10%, X7R |
| C7 | 1 | Capacitor, ceramic, 1 μF, 50 V, 10%, X7R |
| C1, C6, C11 | 4 | Capacitor, ceramic, 0.1 μF, 16 V, 10%, X7R |
| C _{ff} | 1 | Capacitor, ceramic, 22 pF, 35 V, 10%, X7R |
| C10 | 1 | Capacitor, ceramic, 0.1 μF, 50 V, 10% |
| R1, R7 | 2 | Resistor, chip, 100 kΩ, 1/16 W, 0.5% |
| R2 | 1 | Resistor, chip, 900 kΩ, 1/16 W, 0.5% |
| R8 | 1 | Resistor, chip, 22.1 kΩ, 1/16 W, 0.5% |
| R9 | 1 | Resistor, chip, 9.31 kΩ, 1/16 W, 1% |
| R10 | 1 | Resistor, chip, 430 kΩ, 1/16 W, 1% |
| R11 | 1 | Resistor, chip, 2 Ω, 1 W, 5% |
| R13, R14 | 2 | Resistor, chip, 10 kΩ, 1/16 W, 5% |
| R5 | 1 | Resistor, chip, 100 Ω, 1/16 W, 0.5% |
| R6 | 1 | Resistor, chip, 10 Ω, 1 W, 5% |
| D3, D4 | 2 | LED diode, green, 2.1 V, 10 mΩ, Vishay-Dale, WSL2010R0100F |

9.2.2.7 Maximum Output Capacitance

Care must be taken that the total output capacitance at the battery node is not so large that the discharge current source cannot pull the voltage below the LOWV threshold during the 1-second discharge time. The maximum output capacitance can be calculated as seen in Equation 21:

$$C_{MAX} = \frac{I_{DISCH} \times t_{DISCH}}{1.425 \times \left[1 + \frac{R_2}{R_1} \right]}$$

where

- C_{MAX} is the maximum output capacitance.
- I_{DISCH} is the discharge current.
- t_{DISCH} is the discharge time.
- R₂ and R₁ are the voltage feedback resistors from the battery to the VFB pin. (21)

The 1.425 factor is the difference between the RECHARGE and the LOWV thresholds at the VFB pin.

EXAMPLE

For a 3-cell Li+ charger, with R₂ = 500 kΩ, R₁ = 100 kΩ (giving 10.8 V for voltage regulation), I_{DISCH} = 8 mA, t_{DISCH} = 1 second,

$$C_{MAX} = \frac{8\text{mA} \times 1\text{sec}}{1.425 \times \left[1 + \frac{500\text{k}}{100\text{k}} \right]} = 930 \mu\text{F} \quad (22)$$

Based on these calculations, no more than 930 μF should be allowed on the battery node for proper operation of the battery detection circuit.

9.2.3 Application Curves

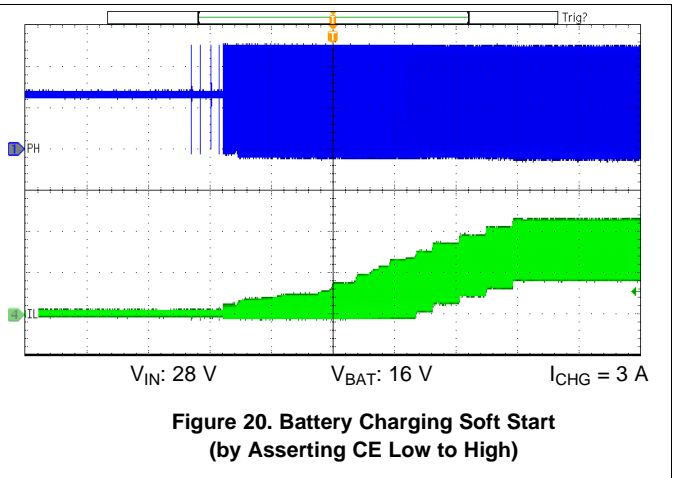
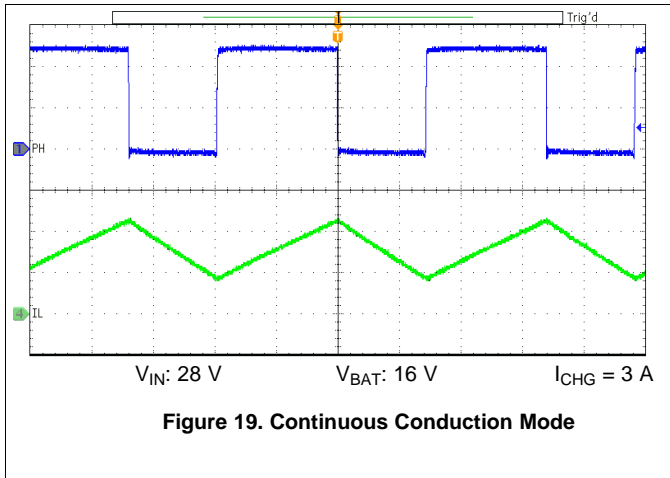

10 Power Supply Recommendations

For proper operation of bq24620, VCC must be from 5 V to 28 V. To begin charging, VCC must be higher than SRN by at least 500 mV (otherwise, the device will be in sleep mode). TI recommends an input voltage of at least 1.5 V to 2 V higher than the battery voltage, taking into consideration the DC losses in the high-side FET (R_{dson}), inductor (DCR), the input diode drop, and battery sense resistor (between SRP and SRN). Power limit for the input supply must be greater than the maximum power required for battery charging.

11 Layout

11.1 Layout Guidelines

The switching node rise and fall times must be minimized for minimum switching loss. Proper layout of the components to minimize the high-frequency current-path loop (see [Figure 21](#)) is important to prevent electrical and magnetic field radiation and high-frequency resonant problems. The following is a PCB layout priority list for proper layout. Layout of the PCB according to this specific order is essential.

1. Place the input capacitor as close as possible to the switching MOSFET supply and ground connections, and use the shortest possible copper trace connection. These parts should be placed on the same layer of the PCB instead of on different layers, using vias to make this connection.
2. The IC must be placed close to the switching MOSFET gate terminals, keeping the gate-drive signal traces short for a clean MOSFET drive. The IC can be placed on the other side of the PCB from the switching MOSFETs.
3. Place the inductor input terminal as close as possible to switching MOSFET output terminal. Minimize the copper area of this trace to lower electrical and magnetic field radiation, but make the trace wide enough to carry the charging current. Do not use multiple layers in parallel for this connection. Minimize parasitic capacitance from this area to any other trace or plane.
4. The charging-current-sensing resistor must be placed right next to the inductor output. Route the sense leads connected across the sensing resistor back to the IC in same layer, close to each other (minimize loop area), and do not route the sense leads through a high-current path (see [Figure 22](#) for Kelvin connection for best current accuracy). Place the decoupling capacitor on these traces next to the IC.
5. Place the output capacitor next to the sensing-resistor output and ground.
6. The output capacitor ground connections must be tied to the same copper that connects to the input capacitor ground before connecting to system ground.
7. Route the analog ground separately from the power ground and use a single ground connection to tie the charger power ground to the charger analog ground. Just beneath the IC, use the copper pour for analog ground, but avoid power pins to reduce inductive and capacitive noise coupling. Connect analog ground to GND. Connect the analog ground and power ground together using the thermal pad as the single ground connection point, or use a 0- Ω resistor to tie analog ground to power ground (the thermal pad should tie to analog ground in this case). A star-connection under the thermal pad is highly recommended.
8. It is critical to solder the exposed thermal pad on the back of the IC package to the PCB ground. Ensure that there are sufficient thermal vias directly under the IC, connecting to the ground plane on the other layers.
9. Place decoupling capacitors next to the IC pins to make trace connections as short as possible.
10. All via sizes and numbers must be enough for a given current path.

See the EVM design ([SLUU410](#)) for the recommended component placement with trace and via locations.

For QFN information, see [SCBA017](#) and [SLUA271](#).

11.2 Layout Example

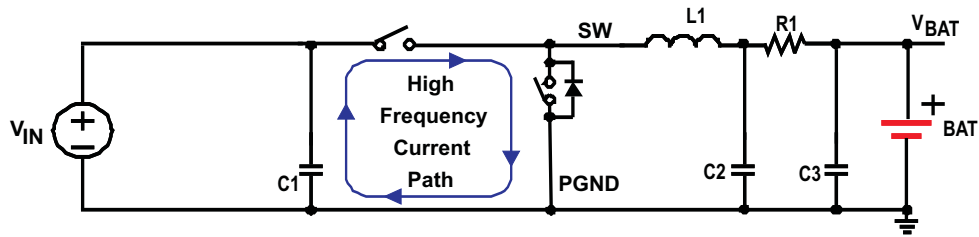

Figure 21. High-Frequency Current Path

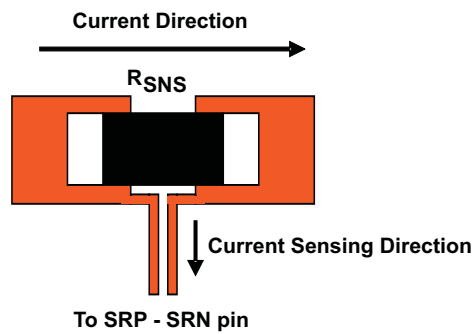

Figure 22. Sensing Resistor PCB Layout

12 Device and Documentation Support

12.1 Device Support

12.1.1 Third-Party Products Disclaimer

TI'S PUBLICATION OF INFORMATION REGARDING THIRD-PARTY PRODUCTS OR SERVICES DOES NOT CONSTITUTE AN ENDORSEMENT REGARDING THE SUITABILITY OF SUCH PRODUCTS OR SERVICES OR A WARRANTY, REPRESENTATION OR ENDORSEMENT OF SUCH PRODUCTS OR SERVICES, EITHER ALONE OR IN COMBINATION WITH ANY TI PRODUCT OR SERVICE.

12.2 Documentation Support

12.2.1 Related Documentation

For related documentation, see the following:

- *bq24600/20/40 EVM (HPA421) Multi Cell Synchronous Switch-Mode Charger*, [SLUU410](#)
- *Quad Flatpack No-Lead Logic Packages*, [SCBA017](#)
- *QFN/SON PCB Attachment*, [SLUA271](#)

12.3 Community Resources

The following links connect to TI community resources. Linked contents are provided "AS IS" by the respective contributors. They do not constitute TI specifications and do not necessarily reflect TI's views; see TI's [Terms of Use](#).

TI E2E™ Online Community *TI's Engineer-to-Engineer (E2E) Community*. Created to foster collaboration among engineers. At [e2e.ti.com](#), you can ask questions, share knowledge, explore ideas and help solve problems with fellow engineers.

Design Support *TI's Design Support* Quickly find helpful E2E forums along with design support tools and contact information for technical support.

12.4 Trademarks

E2E is a trademark of Texas Instruments.
All other trademarks are the property of their respective owners.

12.5 Electrostatic Discharge Caution



These devices have limited built-in ESD protection. The leads should be shorted together or the device placed in conductive foam during storage or handling to prevent electrostatic damage to the MOS gates.

12.6 Glossary

[SLYZ022](#) — *TI Glossary*.

This glossary lists and explains terms, acronyms, and definitions.

13 Mechanical, Packaging, and Orderable Information

The following pages include mechanical, packaging, and orderable information. This information is the most current data available for the designated devices. This data is subject to change without notice and revision of this document. For browser-based versions of this data sheet, refer to the left-hand navigation.

PACKAGING INFORMATION

| Orderable Device | Status (1) | Package Type | Package Drawing | Pins | Package Qty | Eco Plan (2) | Lead/Ball Finish (6) | MSL Peak Temp (3) | Op Temp (°C) | Device Marking (4/5) | Samples |
|------------------|---------------|--------------|-----------------|------|-------------|-------------------------|-------------------------|----------------------|--------------|-------------------------|-------------------------|
| BQ24620RVAR | ACTIVE | VQFN | RVA | 16 | 3000 | Green (RoHS & no Sb/Br) | CU NIPDAU | Level-2-260C-1 YEAR | -40 to 85 | OAR | Samples |
| BQ24620RVAT | ACTIVE | VQFN | RVA | 16 | 250 | Green (RoHS & no Sb/Br) | CU NIPDAU | Level-2-260C-1 YEAR | -40 to 85 | OAR | Samples |

(1) The marketing status values are defined as follows:

ACTIVE: Product device recommended for new designs.

LIFEBUY: TI has announced that the device will be discontinued, and a lifetime-buy period is in effect.

NRND: Not recommended for new designs. Device is in production to support existing customers, but TI does not recommend using this part in a new design.

PREVIEW: Device has been announced but is not in production. Samples may or may not be available.

OBSOLETE: TI has discontinued the production of the device.

(2) Eco Plan - The planned eco-friendly classification: Pb-Free (RoHS), Pb-Free (RoHS Exempt), or Green (RoHS & no Sb/Br) - please check <http://www.ti.com/productcontent> for the latest availability information and additional product content details.

TBD: The Pb-Free/Green conversion plan has not been defined.

Pb-Free (RoHS): TI's terms "Lead-Free" or "Pb-Free" mean semiconductor products that are compatible with the current RoHS requirements for all 6 substances, including the requirement that lead not exceed 0.1% by weight in homogeneous materials. Where designed to be soldered at high temperatures, TI Pb-Free products are suitable for use in specified lead-free processes.

Pb-Free (RoHS Exempt): This component has a RoHS exemption for either 1) lead-based flip-chip solder bumps used between the die and package, or 2) lead-based die adhesive used between the die and leadframe. The component is otherwise considered Pb-Free (RoHS compatible) as defined above.

Green (RoHS & no Sb/Br): TI defines "Green" to mean Pb-Free (RoHS compatible), and free of Bromine (Br) and Antimony (Sb) based flame retardants (Br or Sb do not exceed 0.1% by weight in homogeneous material)

(3) MSL, Peak Temp. - The Moisture Sensitivity Level rating according to the JEDEC industry standard classifications, and peak solder temperature.

(4) There may be additional marking, which relates to the logo, the lot trace code information, or the environmental category on the device.

(5) Multiple Device Markings will be inside parentheses. Only one Device Marking contained in parentheses and separated by a "~" will appear on a device. If a line is indented then it is a continuation of the previous line and the two combined represent the entire Device Marking for that device.

(6) Lead/Ball Finish - Orderable Devices may have multiple material finish options. Finish options are separated by a vertical ruled line. Lead/Ball Finish values may wrap to two lines if the finish value exceeds the maximum column width.

Important Information and Disclaimer: The information provided on this page represents TI's knowledge and belief as of the date that it is provided. TI bases its knowledge and belief on information provided by third parties, and makes no representation or warranty as to the accuracy of such information. Efforts are underway to better integrate information from third parties. TI has taken and continues to take reasonable steps to provide representative and accurate information but may not have conducted destructive testing or chemical analysis on incoming materials and chemicals. TI and TI suppliers consider certain information to be proprietary, and thus CAS numbers and other limited information may not be available for release.

In no event shall TI's liability arising out of such information exceed the total purchase price of the TI part(s) at issue in this document sold by TI to Customer on an annual basis.

TAPE AND REEL INFORMATION



QUADRANT ASSIGNMENTS FOR PIN 1 ORIENTATION IN TAPE



*All dimensions are nominal

| Device | Package Type | Package Drawing | Pins | SPQ | Reel Diameter (mm) | Reel Width W1 (mm) | A0 (mm) | B0 (mm) | K0 (mm) | P1 (mm) | W (mm) | Pin1 Quadrant |
|-------------|--------------|-----------------|------|------|--------------------|--------------------|---------|---------|---------|---------|--------|---------------|
| BQ24620RVAR | VQFN | RVA | 16 | 3000 | 330.0 | 12.4 | 3.75 | 3.75 | 1.15 | 8.0 | 12.0 | Q1 |
| BQ24620RVAT | VQFN | RVA | 16 | 250 | 180.0 | 12.4 | 3.75 | 3.75 | 1.15 | 8.0 | 12.0 | Q1 |

TAPE AND REEL BOX DIMENSIONS

*All dimensions are nominal

| Device | Package Type | Package Drawing | Pins | SPQ | Length (mm) | Width (mm) | Height (mm) |
|-------------|--------------|-----------------|------|------|-------------|------------|-------------|
| BQ24620RVAR | VQFN | RVA | 16 | 3000 | 367.0 | 367.0 | 35.0 |
| BQ24620RVAT | VQFN | RVA | 16 | 250 | 210.0 | 185.0 | 35.0 |

RVA (S-PVQFN-N16)

PLASTIC QUAD FLATPACK NO-LEAD

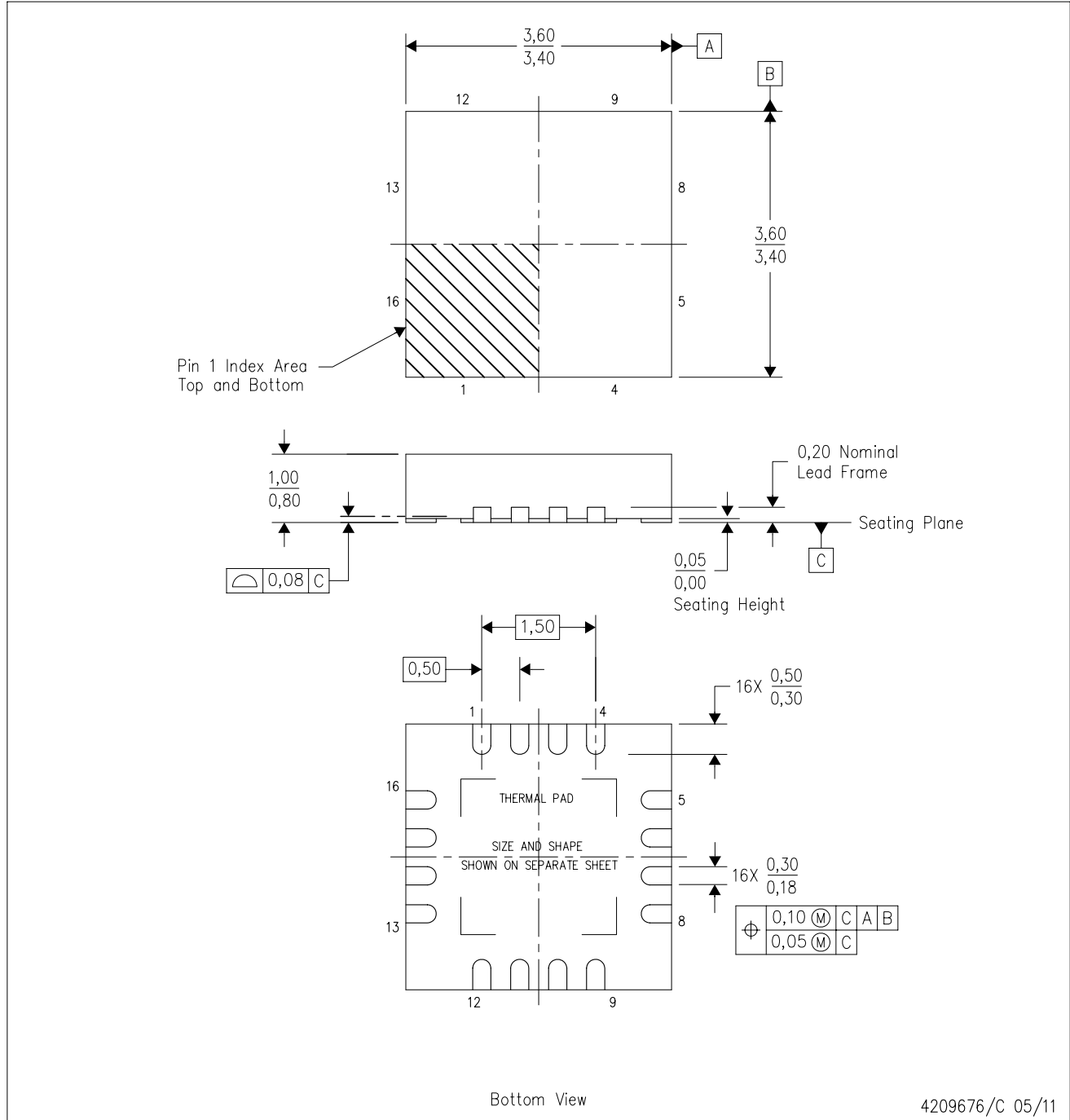

4209676/C 05/11

- NOTES:
- All linear dimensions are in millimeters. Dimensioning and tolerancing per ASME Y14.5M-1994.
 - This drawing is subject to change without notice.
 - QFN (Quad Flatpack No-Lead) package configuration.
 - The package thermal pad must be soldered to the board for thermal and mechanical performance.
 - See the additional figure in the Product Data Sheet for details regarding the exposed thermal pad features and dimensions.

THERMAL PAD MECHANICAL DATA

RVA (S-PVQFN-N16)

PLASTIC QUAD FLATPACK NO-LEAD

THERMAL INFORMATION

This package incorporates an exposed thermal pad that is designed to be attached directly to an external heatsink. The thermal pad must be soldered directly to the printed circuit board (PCB). After soldering, the PCB can be used as a heatsink. In addition, through the use of thermal vias, the thermal pad can be attached directly to the appropriate copper plane shown in the electrical schematic for the device, or alternatively, can be attached to a special heatsink structure designed into the PCB. This design optimizes the heat transfer from the integrated circuit (IC).

For information on the Quad Flatpack No-Lead (QFN) package and its advantages, refer to Application Report, QFN/SON PCB Attachment, Texas Instruments Literature No. SLUA271. This document is available at www.ti.com.

The exposed thermal pad dimensions for this package are shown in the following illustration.

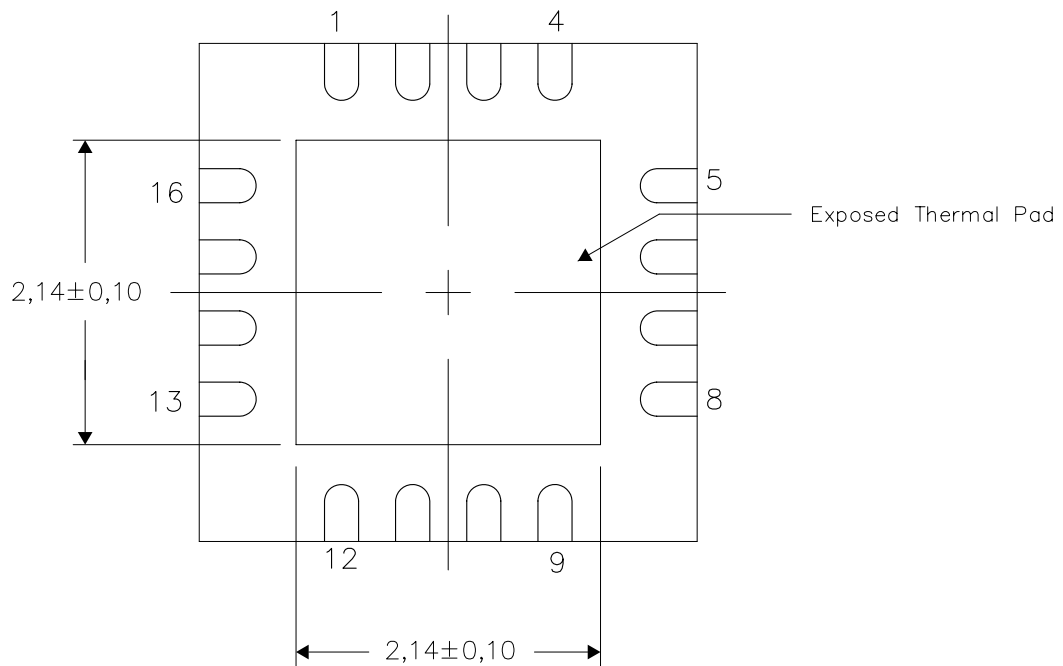

4209715/B 05/11

NOTE: All linear dimensions are in millimeters

RVA (S-PVQFN-N16)

PLASTIC QUAD FLATPACK NO-LEAD

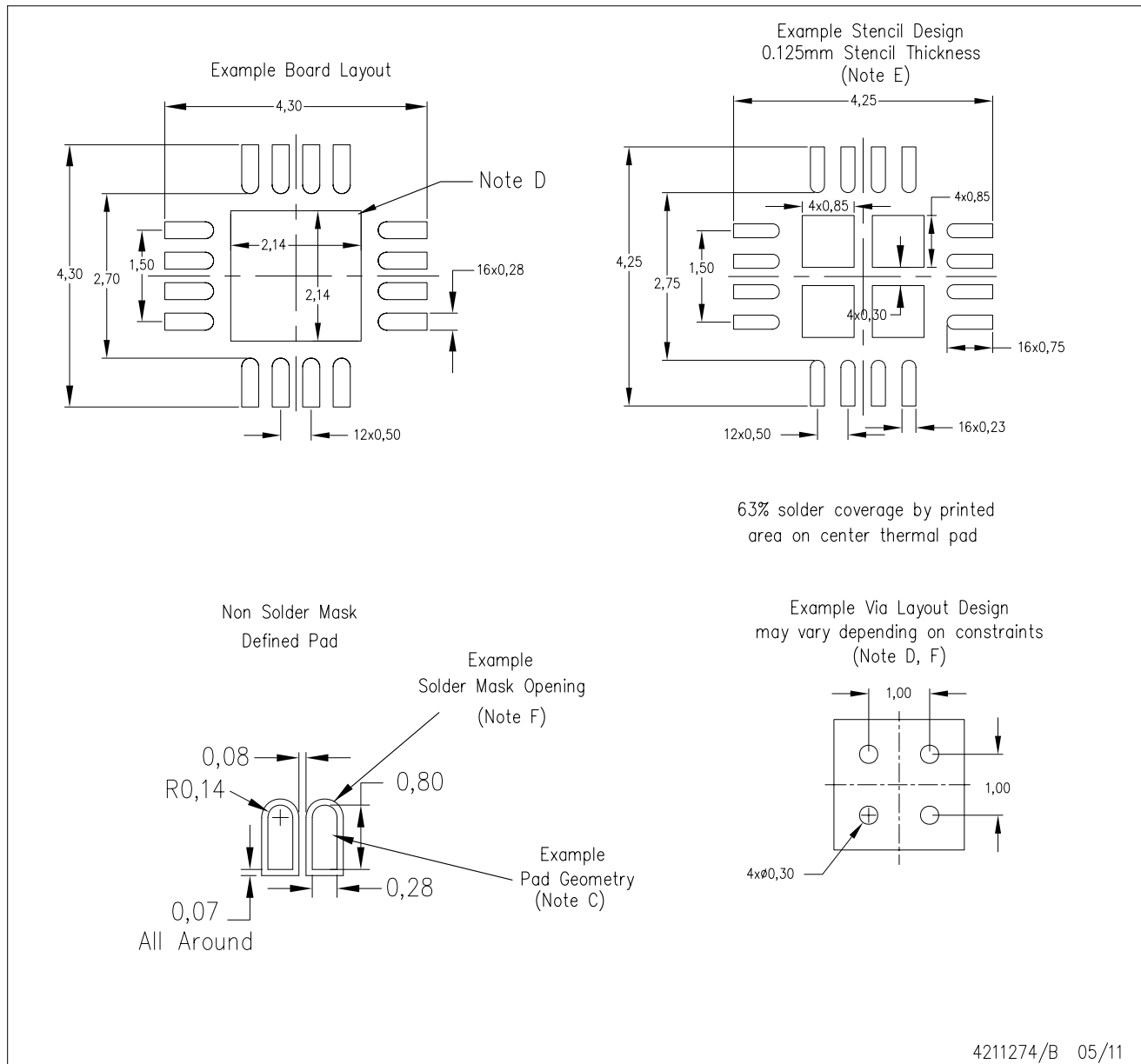

- NOTES:
- All linear dimensions are in millimeters.
 - This drawing is subject to change without notice.
 - Publication IPC-7351 is recommended for alternate designs.
 - This package is designed to be soldered to a thermal pad on the board. Refer to Application Note, Quad Flat-Pack QFN/SON PCB Attachment, Texas Instruments Literature No. SLUA271, and also the Product Data Sheets for specific thermal information, via requirements, and recommended board layout. These documents are available at www.ti.com <<http://www.ti.com>>.
 - Laser cutting apertures with trapezoidal walls and also rounding corners will offer better paste release. Customers should contact their board assembly site for stencil design recommendations. Refer to IPC 7525 for stencil design considerations.
 - Customers should contact their board fabrication site for minimum solder mask web tolerances between signal pads.

IMPORTANT NOTICE

Texas Instruments Incorporated and its subsidiaries (TI) reserve the right to make corrections, enhancements, improvements and other changes to its semiconductor products and services per JESD46, latest issue, and to discontinue any product or service per JESD48, latest issue. Buyers should obtain the latest relevant information before placing orders and should verify that such information is current and complete. All semiconductor products (also referred to herein as "components") are sold subject to TI's terms and conditions of sale supplied at the time of order acknowledgment.

TI warrants performance of its components to the specifications applicable at the time of sale, in accordance with the warranty in TI's terms and conditions of sale of semiconductor products. Testing and other quality control techniques are used to the extent TI deems necessary to support this warranty. Except where mandated by applicable law, testing of all parameters of each component is not necessarily performed.

TI assumes no liability for applications assistance or the design of Buyers' products. Buyers are responsible for their products and applications using TI components. To minimize the risks associated with Buyers' products and applications, Buyers should provide adequate design and operating safeguards.

TI does not warrant or represent that any license, either express or implied, is granted under any patent right, copyright, mask work right, or other intellectual property right relating to any combination, machine, or process in which TI components or services are used. Information published by TI regarding third-party products or services does not constitute a license to use such products or services or a warranty or endorsement thereof. Use of such information may require a license from a third party under the patents or other intellectual property of the third party, or a license from TI under the patents or other intellectual property of TI.

Reproduction of significant portions of TI information in TI data books or data sheets is permissible only if reproduction is without alteration and is accompanied by all associated warranties, conditions, limitations, and notices. TI is not responsible or liable for such altered documentation. Information of third parties may be subject to additional restrictions.

Resale of TI components or services with statements different from or beyond the parameters stated by TI for that component or service voids all express and any implied warranties for the associated TI component or service and is an unfair and deceptive business practice. TI is not responsible or liable for any such statements.

Buyer acknowledges and agrees that it is solely responsible for compliance with all legal, regulatory and safety-related requirements concerning its products, and any use of TI components in its applications, notwithstanding any applications-related information or support that may be provided by TI. Buyer represents and agrees that it has all the necessary expertise to create and implement safeguards which anticipate dangerous consequences of failures, monitor failures and their consequences, lessen the likelihood of failures that might cause harm and take appropriate remedial actions. Buyer will fully indemnify TI and its representatives against any damages arising out of the use of any TI components in safety-critical applications.

In some cases, TI components may be promoted specifically to facilitate safety-related applications. With such components, TI's goal is to help enable customers to design and create their own end-product solutions that meet applicable functional safety standards and requirements. Nonetheless, such components are subject to these terms.

No TI components are authorized for use in FDA Class III (or similar life-critical medical equipment) unless authorized officers of the parties have executed a special agreement specifically governing such use.

Only those TI components which TI has specifically designated as military grade or "enhanced plastic" are designed and intended for use in military/aerospace applications or environments. Buyer acknowledges and agrees that any military or aerospace use of TI components which have **not** been so designated is solely at the Buyer's risk, and that Buyer is solely responsible for compliance with all legal and regulatory requirements in connection with such use.

TI has specifically designated certain components as meeting ISO/TS16949 requirements, mainly for automotive use. In any case of use of non-designated products, TI will not be responsible for any failure to meet ISO/TS16949.

Products

| | |
|------------------------------|--|
| Audio | www.ti.com/audio |
| Amplifiers | amplifier.ti.com |
| Data Converters | dataconverter.ti.com |
| DLP® Products | www.dlp.com |
| DSP | dsp.ti.com |
| Clocks and Timers | www.ti.com/clocks |
| Interface | interface.ti.com |
| Logic | logic.ti.com |
| Power Mgmt | power.ti.com |
| Microcontrollers | microcontroller.ti.com |
| RFID | www.ti-rfid.com |
| OMAP Applications Processors | www.ti.com/omap |
| Wireless Connectivity | www.ti.com/wirelessconnectivity |

Applications

| | |
|-------------------------------|--|
| Automotive and Transportation | www.ti.com/automotive |
| Communications and Telecom | www.ti.com/communications |
| Computers and Peripherals | www.ti.com/computers |
| Consumer Electronics | www.ti.com/consumer-apps |
| Energy and Lighting | www.ti.com/energy |
| Industrial | www.ti.com/industrial |
| Medical | www.ti.com/medical |
| Security | www.ti.com/security |
| Space, Avionics and Defense | www.ti.com/space-avionics-defense |
| Video and Imaging | www.ti.com/video |

TI E2E Community

e2e.ti.com

Looking for pricing, stock, or lifecycle information?

Click below to explore more details on WIN SOURCE:

 [View BQ24620RVAT](#) on WIN SOURCE

 [Texas Instruments](#) Information

Optimize Your Supply Chain with WIN SOURCE Solutions

-  Global Sourcing Solution
-  Obsolete Management
-  Cost Control Management
-  Shortage Management
-  Alternative Solution
-  Excess Inventory Management