



**THE DATASHEET OF
BQ24153YFFT**



Fully Integrated Switch-Mode One-Cell Li-Ion Charger With Full USB Compliance and USB-OTG Support

Check for Samples: [bq24153](#), [bq24156](#), [bq24158](#)

FEATURES

- Charge Faster than Linear Chargers
- High-Accuracy Voltage and Current Regulation
 - Input Current Regulation Accuracy: $\pm 5\%$ (100 mA and 500 mA)
 - Charge Voltage Regulation Accuracy: $\pm 0.5\%$ (25°C), $\pm 1\%$ (0°C to 125°C)
 - Charge Current Regulation Accuracy: $\pm 5\%$
- Input Voltage Based Dynamic Power Management (VIN DPM)
- Bad adaptor detection and rejection
- Safety limit register for maximum charge voltage and current limiting
- High-Efficiency Mini-USB/AC Battery Charger for Single-Cell Li-Ion and Li-Polymer Battery Packs
- 20-V Absolute Maximum Input Voltage Rating
- 9.0-V Maximum Operating Input Voltage-bq24156
- 6-V Maximum Operating Input Voltage-bq24153/8
- Built-In Input Current Sensing and Limiting
- Integrated Power FETs for Up To 1.5-A Charge Rate-bq24156, 1.25A-bq24153/8
- Programmable Charge Parameters through I²C™ Compatible Interface (up to 3.4 Mbps):
 - Input Current Limit
 - VIN DPM Threshold
 - Fast-Charge/Termination Current
 - Charge Regulation Voltage (3.5 V to 4.44 V)
 - Low Charge Current Mode Enable/Disable
 - Safety Timer with Reset Control
 - Termination Enable/Disable
- Synchronous Fixed-Frequency PWM Controller Operating at 3 MHz With 0% to 99.5% Duty Cycle
- Automatic High Impedance Mode for Low Power Consumption
- Robust Protection

- Reverse Leakage Protection Prevents Battery Drainage
- Thermal Regulation and Protection
- Input/Output Overvoltage Protection
- Status Output for Charging and Faults
- USB Friendly Boot-Up Sequence
- Automatic Charging
- Power Up System without Battery bq24158
- Boost Mode Operation for USB OTG: (bq24153/8 only)
 - Input Voltage Range (from Battery): 2.5 V to 4.5 V
 - Output for V_{BUS}: 5.05 V/ 200 mA
- 2.1 mm x 2 mm 20-Pin WCSP Package

APPLICATIONS

- Mobile and Smart Phones
- MP3 Players
- Handheld Devices

Typical Application Circuit

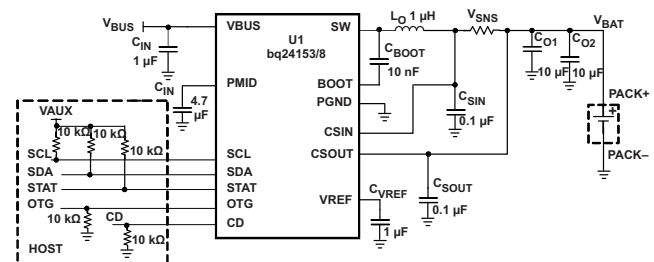

DESCRIPTION

The bq24153/6/8 is a compact, flexible, high-efficiency, USB-friendly switch-mode charge management device for single-cell Li-ion and Li-polymer batteries used in a wide range of portable applications. The charge parameters can be programmed through an I²C interface. The IC integrates a synchronous PWM controller, power MOSFETs, input current sensing, high-accuracy current and voltage regulation, and charge termination, into a small WCSP package.



Please be aware that an important notice concerning availability, standard warranty, and use in critical applications of Texas Instruments semiconductor products and disclaimers thereto appears at the end of this data sheet.

I²C is a trademark of Philips Electronics.

The IC charges the battery in three phases: conditioning, constant current and constant voltage. The input current is automatically limited to the value set by the host. Charge is terminated based on battery voltage and user-selectable minimum current level. A safety timer with reset control provides a safety backup for I²C interface. During normal operation, The IC automatically restarts the charge cycle if the battery voltage falls below an internal threshold and automatically enters sleep mode or high impedance mode when the input supply is removed. The charge status can be reported to the host using the I²C interface. During the charging process, the IC monitors its junction temperature (T_J) and reduces the charge current once T_J increases to about 125°C. To support USB OTG device, bq24153/8 can provide V_{BUS} (5.05V) by boosting the battery voltage. The IC is available in 20-pin WCSP package.

DEVICE SPINS AND COMPARISONS

PART NUMBER	bq24153	bq24156	bq24158
VOVP (V)	6.5	9.8	6.5
D4 Pin Definition	OTG	SLRST	OTG
Maximum Charge Current (A)	1.25	1.55	1.25
Boost Function	Yes	No	Yes
Input Current Limit in 15Min Mode	100mA (OTG=LOW); 500mA (OTG=High)	500mA	100mA (OTG=LOW); 500mA (OTG=High)
Battery Detection at Power Up	Yes	Yes	No
I2C Address	6BH	6AH	6AH
PN1 (bit4 of 03H)	1	0	1
PN0 (bit3 of 03H)	0	0	0

PIN LAYOUT (20-Bump YFF Package)

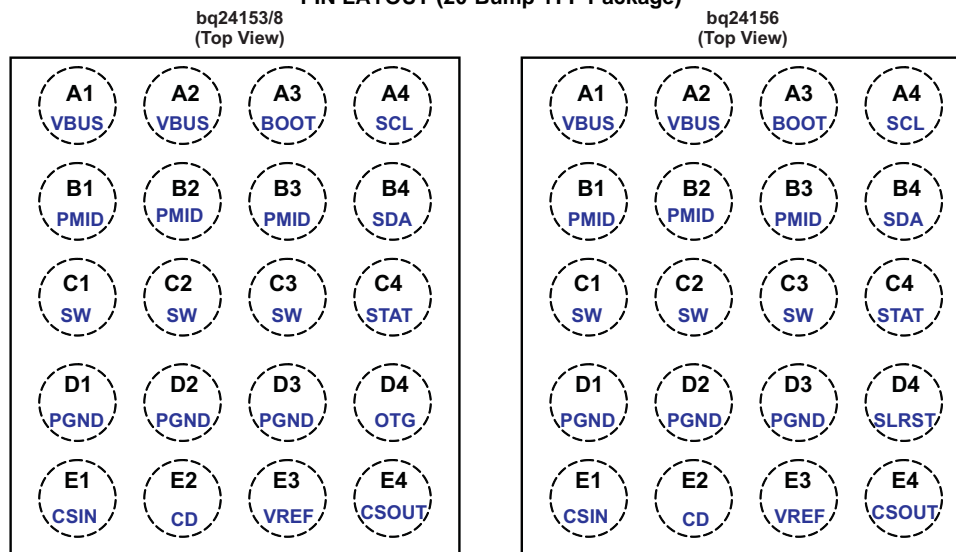

PIN FUNCTIONS

PIN		I/O	DESCRIPTION
NAME	NO.		
CSOUT	E4	I	Battery voltage and current sense input. Bypass it with a ceramic capacitor (minimum 0.1 μF) to PGND if there are long inductive leads to battery.
VBUS	A1, A2	I/O	Charger input voltage. Bypass it with a 1-μF ceramic capacitor from VBUS to PGND. It also provides power to the load during boost mode (bq24153/8 only) .
PMID	B1, B2, B3	I/O	Connection point between reverse blocking FET and high-side switching FET. Bypass it with a minimum of 3.3-μF capacitor from PMID to PGND.
SW	C1, C2, C3	O	Internal switch to output inductor connection.
BOOT	A3	I/O	Bootstrap capacitor connection for the high-side FET gate driver. Connect a 10-nF ceramic capacitor (voltage rating ≥ 10 V) from BOOT pin to SW pin.
PGND	D1, D2, D3		Power ground
CSIN	E1	I	Charge current-sense input. Battery current is sensed across an external sense resistor. A 0.1-μF ceramic capacitor to PGND is required.
SCL	A4	I	I ² C interface clock. Connect a 10-kΩ pullup resistor to 1.8V rail (V _{AUX} =V _{CC_HOST})
SDA	B4	I/O	I ² C interface data. Connect a 10-kΩ pullup resistor to 1.8V rail (V _{AUX} =V _{CC_HOST})

PIN FUNCTIONS (continued)

PIN		I/O	DESCRIPTION
NAME	NO.		
STAT	C4	O	Charge status pin. Pull low when charge in progress. Open drain for other conditions. During faults, a 128- μ s pulse is sent out. STAT pin can be disabled by the EN_STAT bit in control register. STAT can be used to drive a LED or communicate with a host processor.
VREF	E3	O	Internal bias regulator voltage. Connect a 1 μ F ceramic capacitor from this output to PGND. External load on VREF is not recommended.
CD	E2	I	Charge disable control pin. CD=0, charge is enabled. CD=1, charge is disabled and VBUS pin is high impedance to GND. In 15min mode, Setting CD=1 resets the 15min timer; while in 32s mode, Setting CD=1 will NOT reset the 32-second timer.
OTG (bq24153/8 only)	D4	I	Boost mode enable control or input current limiting selection pin. When OTG is in active status, bq24153/8 is forced to operate in boost mode. It has higher priority over I ² C control and can be disabled using the control register. At POR, the OTG pin is default to be used as the input current limiting selection pin. When OTG=High, I _{IN_LIMIT} =500mA and when OTG=Low, I _{IN_LIMIT} =100mA, refer to Control Register for detail.
SLRST (bq24156 only)	D4	I	Safety limit register reset control. When SLRST=0, bq24156 resets all the safety limits (06H) to default values, regardless of the write actions to safety limits registers (06H). When SLRST=1, bq24156 can program the safety limit register until any write action to other registers locks the programmed safety limits.

ORDERING INFORMATION⁽¹⁾

PART NUMBER	MARKING	MEDIUM	QUANTITY
bq24153YFFR	bq24153	Tape and Reel	3000
bq24153YFFT	bq24153	Tape and Reel	250
bq24156YFFR	bq24156	Tape and Reel	3000
bq24156YFFT	bq24156	Tape and Reel	250
bq24158YFFR	bq24158	Tape and Reel	3000
bq24158YFFT	bq24158	Tape and Reel	250

(1) For the most current package and ordering information, see the Package Option Addendum at the end of this document, or see the TI website at www.ti.com.

PACKAGE DISSIPATION RATINGS⁽¹⁾

PACKAGE	R _{θJA}	R _{θJC}	T _A ≤ 25°C POWER RATING	DERATING FACTOR T _A > 25°C
WSCP-20 ⁽¹⁾	76°C/W ⁽²⁾	1.57°C/W	1.32 W	0.0132 W/°C

(1) Maximum power dissipation is a function of T_{J(max)}, R_{θJA} and T_A. The maximum allowable power dissipation at any allowable ambient temperature is P_D = [T_{J(max)} - T_A] / R_{θJA}.

(2) Using JEDEC 4-layer High-K board.

ABSOLUTE MAXIMUM RATINGS^{(1) (2)}

over operating free-air temperature range (unless otherwise noted)

		bq24153/6/8	UNIT
Supply voltage range (with respect to PGND ⁽³⁾)	VBUS; $V_{PMID} \geq V_{BUS} - 0.3$ V	-2 to 20	V
Input voltage range (with respect to PGND ⁽³⁾)	SCL, SDA, OTG, SLRST, CSIN, CSOUT, CD	-0.3 to 7	V
Output voltage range (with respect to PGND ⁽³⁾)	PMID, STAT	-0.3 to 20	V
	VREF	7	V
	SW, BOOT	-0.7 to 20	V
Voltage difference between CSIN and CSOUT inputs ($V_{(CSIN)} - V_{(CSOUT)}$)		± 7	V
Voltage difference between BOOT and SW inputs ($V_{(BOOT)} - V_{(SW)}$)		-0.3 to 7	V
Voltage difference between VBUS and PMID inputs ($V_{(VBUS)} - V_{(PMID)}$)		-7 to 0.7	V
Voltage difference between PMID and SW inputs ($V_{(PMID)} - V_{(SW)}$)		-0.7 to 20	V
Output sink	STAT	10	mA
Output Current (average)	SW	1.55 ⁽²⁾	A
T_A	Operating free-air temperature range	-30 to 85	°C
T_J	Junction temperature	-40 to 125	°C
T_{stg}	Storage temperature	-45 to 150	°C

- (1) Stresses beyond those listed under *absolute maximum ratings* may cause permanent damage to the device. These are stress ratings only, and functional operation of the device at these or any other conditions beyond those indicated under *recommended operating conditions* is not implied. Exposure to absolute-maximum-rated conditions for extended periods may affect device reliability. All voltage values are with respect to the network ground terminal unless otherwise noted.
- (2) Duty cycle for output current should be less than 50% for 10- year life time when output current is above 1.25A.
- (3) All voltages are with respect to PGND if not specified. Currents are positive into, negative out of the specified terminal, if not specified. Consult Packaging Section of the data sheet for thermal limitations and considerations of packages.

RECOMMENDED OPERATING CONDITIONS

		MIN	NOM	MAX	UNIT
V_{BUS}	Supply voltage, bq24153/8	4.0		6 ⁽¹⁾	V
V_{BUS}	Supply voltage, bq24156	4.0		9 ⁽¹⁾	V
T_J	Operating junction temperature range	-40		+125	°C

- (1) The inherent switching noise voltage spikes should not exceed the absolute maximum rating on either the BOOST or SW pins. A *tight* layout minimizes switching noise.

ELECTRICAL CHARACTERISTICS

Circuit of [Figure 1](#), V_{BUS} = 5 V, HZ_MODE = 0, OPA_MODE = 0 (CD = 0), T_J = –40°C to 125°C, T_J = 25°C for typical values (unless otherwise noted)

PARAMETER		TEST CONDITIONS	MIN	TYP	MAX	UNIT
INPUT CURRENTS						
I _(VBUS)	V _{BUS} supply current control	V _{BUS} > V _{BUS(min)} , PWM switching		10		mA
		V _{BUS} > V _{BUS(min)} , PWM NOT switching			5	
		0°C < T _J < 85°C, CD=1 or HZ_MODE=1		15		23
I _(vbus_leak)	Leakage current from battery to VBUS pin	0°C < T _J < 85°C, V _(CSOUT) = 4.2 V, High Impedance mode, V _{BUS} =0 V			5	μA
	Battery discharge current in High Impedance mode, (CSIN, CSOUT, SW pins)	0°C < T _J < 85°C, V _(CSOUT) = 4.2 V, High Impedance mode, V _(BUS) = 0 V, SCL, SDA, OTG = 0 V or 1.8 V			23	μA
VOLTAGE REGULATION						
V _(OREG)	Output regulation voltage programmable range	Operating in voltage regulation, programmable	3.5		4.44	V
	Voltage regulation accuracy	T _A = 25°C	–0.5%		0.5%	
			–1%		1%	
CURRENT REGULATION (FAST CHARGE)						
I _{O(CHARGE)}	Output charge current programmable range	bq24153, V _(LOWV) ≤ V _(CSOUT) < V _(OREG) , V _{BUS} > V _(SLP) , R _(SNS) = 68 mΩ, LOW_CHG=0, Programmable	550		1250	mA
		bq24156, V _(LOWV) ≤ V _(CSOUT) < V _(OREG) , V _{BUS} > V _(SLP) , R _(SNS) = 68 mΩ, LOW_CHG=0, Programmable	550		1550	
	Low charge current	V _(LOWV) ≤ V _(CSOUT) < V _(OREG) , V _{BUS} > V _(SLP) , R _(SNS) = 68 mΩ, LOW_CHG=1		325		350
	Regulation accuracy of the voltage across R _(SNS) (for charge current regulation) V _(IREG) = I _{O(CHARGE)} × R _(SNS)	37.4 mV ≤ V _(IREG) < 44.2 mV	–3.5%		3.5%	
		44.2 mV ≤ V _(IREG)	–3%		3%	
WEAK BATTERY DETECTION						
V _(LOWV)	Weak battery voltage threshold programmable range	Adjustable using I ² C control	3.4		3.7	V
	Weak battery voltage accuracy		–5%		5%	
	Hysteresis for V _(LOWV)	Battery voltage falling		100		mV
	Deglintch time for weak battery threshold	Rising voltage, 2-mV over drive, t _{RISE} = 100 ns		30		ms
CD, OTG and SLRST PIN LOGIC LEVEL						
V _{IL}	Input low threshold level				0.4	V
V _{IH}	Input high threshold level			1.3		V
I _(bias)	Input bias current	Voltage on control pin is 5 V			1.0	μA
CHARGE TERMINATION DETECTION						
I _(TERM)	Termination charge current programmable range	V _(CSOUT) > V _(OREG) – V _(RCH) , V _{BUS} > V _(SLP) , R _(SNS) = 68 mΩ, Programmable	50		400	mA
	Deglintch time for charge termination	Both rising and falling, 2-mV overdrive, t _{RISE} , t _{FALL} = 100 ns		30		ms
	Regulation accuracy for termination current across R _(SNS) V _(IREG_TERM) = I _{O(TERM)} × R _(SNS)	3.4 mV ≤ V _(IREG_TERM) ≤ 6.8 mV	–15%		15%	
		6.8 mV < V _(IREG_TERM) ≤ 17 mV	–10%		10%	
		17 mV < V _(IREG_TERM) ≤ 27.2 mV	–5.5%		5.5%	

ELECTRICAL CHARACTERISTICS (continued)

Circuit of Figure 1, VBUS = 5 V, HZ_MODE = 0, OPA_MODE = 0 (CD = 0), T_J = -40°C to 125°C, T_J = 25°C for typical values (unless otherwise noted)

PARAMETER		TEST CONDITIONS	MIN	TYP	MAX	UNIT	
BAD ADAPTOR DETECTION							
V _{IN(min)}	Input voltage lower limit	BAD ADAPTOR DETECTION	3.6	3.8	4.0	V	
	Deglintch time for VBUS rising above V _{IN(min)}	Rising voltage, 2-mV overdrive, t _{RISE} = 100 ns		30		ms	
	Hysteresis for V _{IN(min)}	Input voltage rising	100		200	mV	
I _{SHORT}	Current source to GND	During bad adaptor detection	20	30	40	mA	
t _{INT}	Detection Interval	Input power source detection		2		S	
INPUT BASED DYNAMIC POWER MANAGEMENT							
V _{IN_DPM}	Input Voltage DPM threshold programmable range		4.2		4.76	V	
	VIN DPM threshold accuracy		-3%		1%		
INPUT CURRENT LIMITING							
I _{IN_LIMIT}	Input current limiting threshold	I _{IN} = 100 mA	T _J = 0°C – 125°C	88	93	98	mA
			T _J = -40°C – 125°C	86	93	98	
		I _{IN} = 500 mA	T _J = 0°C – 125°C	450	475	500	mA
			T _J = -40°C – 125°C	440	475	500	
VREF BIAS REGULATOR							
V _{REF}	Internal bias regulator voltage	VBUS > V _{IN(min)} or V _(CSOUT) > V _(BATMIN) , I _(VREF) = 1 mA, C _(VREF) = 1 μF	2		6.5	V	
	V _{REF} output short current limit			30		mA	
BATTERY RECHARGE THRESHOLD							
V _(RCH)	Recharge threshold voltage	Below V _(OREG)	100	120	150	mV	
	Deglintch time	V _(SCOUT) decreasing below threshold, t _{FALL} = 100 ns, 10-mV overdrive		130		ms	
STAT OUTPUTS							
V _{OL(STAT)}	Low-level output saturation voltage, STAT pin	I _O = 10 mA, sink current			0.55	V	
	High-level leakage current for STAT	Voltage on STAT pin is 5 V			1	μA	
I²C BUS LOGIC LEVELS AND TIMING CHARACTERISTICS							
V _{OL}	Output low threshold level	I _O = 10 mA, sink current			0.4	V	
V _{IL}	Input low threshold level	V _(pull-up) = 1.8 V, SDA and SCL			0.4	V	
V _{IH}	Input high threshold level	V _(pull-up) = 1.8 V, SDA and SCL	1.2			V	
I _(BIAS)	Input bias current	V _(pull-up) = 1.8 V, SDA and SCL			1	μA	
f _(SCL)	SCL clock frequency				3.4	MHz	
BATTERY DETECTION							
I _(DETECT)	Battery detection current before charge done (sink current) ⁽¹⁾	Begins after termination detected, V _{CSOUT} ≤ V _(OREG)		-0.5		mA	
t _{DETECT}	Battery detection time			262		ms	
SLEEP COMPARATOR							
V _(SLP)	Sleep-mode entry threshold, V _{BUS} - V _{CSOUT}	2.3 V ≤ V _(CSOUT) ≤ V _(OREG) , V _{BUS} falling	0	40	100	mV	
V _(SLP_EXIT)	Sleep-mode exit hysteresis	2.3 V ≤ V _(CSOUT) ≤ V _(OREG)	140	200	260	mV	
	Deglintch time for VBUS rising above V _(SLP) + V _(SLP_EXIT)	Rising voltage, 2-mV overdrive, t _{RISE} = 100 ns		30		ms	
UNDERVOLTAGE LOCKOUT (UVLO)							
V _{UVLO}	IC active threshold voltage	V _{BUS} rising - Exits UVLO	3.05	3.3	3.55	V	
V _{UVLO(HYS)}	IC active hysteresis	V _{BUS} falling below V _{UVLO} - Enters UVLO	120	150		mV	

(1) Bottom N-channel FET always turns on for ~30 ns and then turns off if current is too low.

ELECTRICAL CHARACTERISTICS (continued)

Circuit of Figure 1, V_{BUS} = 5 V, HZ_MODE = 0, OPA_MODE = 0 (CD = 0), T_J = –40°C to 125°C, T_J = 25°C for typical values (unless otherwise noted)

PARAMETER		TEST CONDITIONS	MIN	TYP	MAX	UNIT
PWM						
	Voltage from BOOT pin to SW pin	During charge or boost operation			6.5	V
	Internal top reverse blocking MOSFET on-resistance	I _{IN(LIMIT)} = 500 mA, Measured from V _{BUS} to PMID		180	250	mΩ
	Internal top N-channel Switching MOSFET on-resistance	Measured from PMID to SW, V _{BOOT} – V _{SW} = 4V		120	250	
	Internal bottom N-channel MOSFET on-resistance	Measured from SW to PGND		110	210	
f _(OSC)	Oscillator frequency			3.0		MHz
	Frequency accuracy		–10%		10%	
D _(MAX)	Maximum duty cycle			99.5%		
D _(MIN)	Minimum duty cycle		0			
	Synchronous mode to non-synchronous mode transition current threshold ⁽²⁾	Low-side MOSFET cycle-by-cycle current sensing		100		mA
CHARGE MODE PROTECTION						
V _{OVP_IN_USB}	Input VBUS OVP threshold voltage (bq24153/8)	V _{BUS} threshold to turn off converter during charge	6.3	6.5	6.7	V
	V _(OVP_IN_USB) hysteresis (bq24153/8)	V _{BUS} falling from above V _(OVP_IN_USB)		170		mV
V _{OVP_IN_DYN}	Input VBUS OVP threshold voltage (bq24156)	Threshold over V _{BUS} to turn off converter during charge	9.57	9.8	10	
	V _(OVP_IN_DYN) hysteresis (bq24156)	V _{BUS} falling from above V _(OVP_IN_DYN)		140		
V _{OVP}	Output OVP threshold voltage	V _(CSOUT) threshold over V _(OREG) to turn off charger during charge	110	117	121	%V _{OREG}
	V _(OVP) hysteresis	Lower limit for V _(CSOUT) falling from above V _(OVP)		11		
I _{LIMIT}	Cycle-by-cycle current limit for charge	Charge mode operation	1.8	2.4	3.0	A
V _{SHORT}	Trickle to fast charge threshold	V _(CSOUT) rising	2.0	2.1	2.2	V
	V _{SHORT} hysteresis	V _(CSOUT) falling below V _{SHORT}		100		mV
I _{SHORT}	Trickle charge charging current	V _{(CSOUT) ≤ V_{SHORT}}	20	30	40	mA
BOOST MODE OPERATION FOR V_{BUS} (OPA_MODE = 1, HZ_MODE = 0, bq24153/8 only)						
V _{BUS_B}	Boost output voltage (to VBUS pin)	2.5V < V _(CSOUT) < 4.5 V		5.05		V
	Boost output voltage accuracy	Including line and load regulation	–3%		3%	
I _{BO}	Maximum output current for boost	V _{BUS_B} = 5.05 V, 2.5 V < V _(CSOUT) < 4.5 V	200			mA
I _{BLIMIT}	Cycle by cycle current limit for boost	V _{BUS_B} = 5.05 V, 2.5 V < V _(CSOUT) < 4.5 V		1.0		A
V _{BUSOVP}	Overvoltage protection threshold for boost (VBUS pin)	Threshold over VBUS to turn off converter during boost	5.8	6.0	6.2	V
	V _{BUSOVP} hysteresis	V _{BUS} falling from above V _{BUSOVP}		162		mV
V _{BATMAX}	Maximum battery voltage for boost (CSOUT pin)	V _(CSOUT) rising edge during boost	4.75	4.9	5.05	V
	V _{BATMAX} hysteresis	V _(CSOUT) falling from above V _{BATMAX}		200		mV
V _{BATMIN}	Minimum battery voltage for boost (CSOUT pin)	During boosting		2.5		V
		Before boost starts		2.9	3.05	V
	Boost output resistance at high-impedance mode (From VBUS to PGND)	CD = 1 or HZ_MODE = 1	217			kΩ
PROTECTION						
T _{SHTDWN)}	Thermal trip			165		°C
	Thermal hysteresis			10		
T _{CF}	Thermal regulation threshold	Charge current begins to reduce		120		
T _{32S}	32 second timer	32 Second mode	15	32		s
T _{15M}	15 minute timer	15 Minute mode	12		15	m

(2) Bottom N-channel FET always turns on for ~30 ns and then turns off if current is too low.

TYPICAL APPLICATION CIRCUITS

$V_{BUS} = 5\text{ V}$, $I_{CHARGE} = 1250\text{ mA}$, $V_{BAT} = 3.5\text{ V to } 4.44\text{ V}$ (Adjustable).

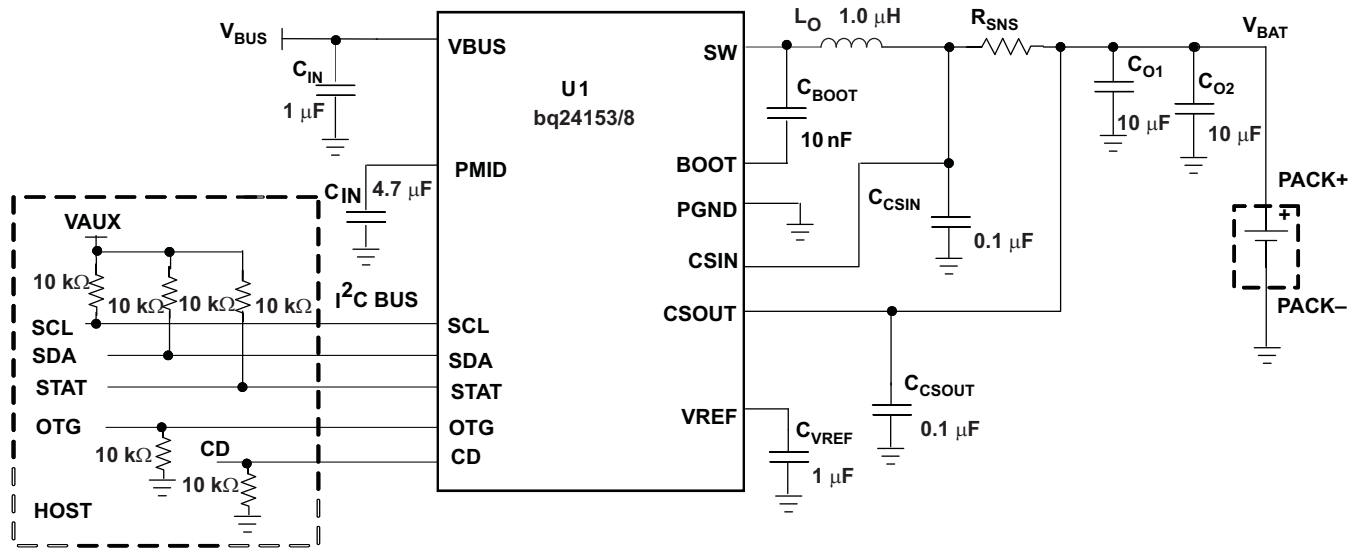

Figure 1. I²C Controlled 1-Cell USB Charger Application Circuit with USB OTG Support.

$V_{BUS} = 5\text{ V}$, $I_{CHARGE} = 1550\text{ mA}$, $V_{bat} = 3.5\text{ V to } 4.44\text{ V}$ (adjustable).

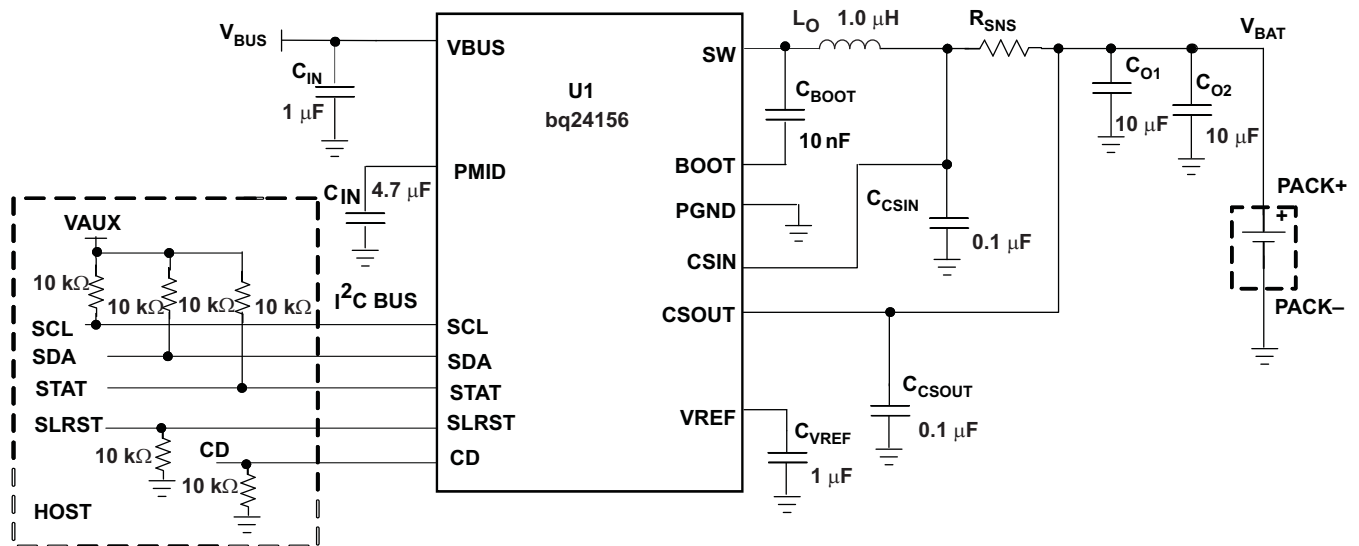

Figure 2. I²C Controlled 1-Cell Charger Application Circuit with External Safety Limit Register Control.

TYPICAL PERFORMANCE CHARACTERISTICS

Using circuit shown in [Figure 1](#), $T_A = 25^\circ\text{C}$, unless otherwise specified.

ADAPTER INSERTION

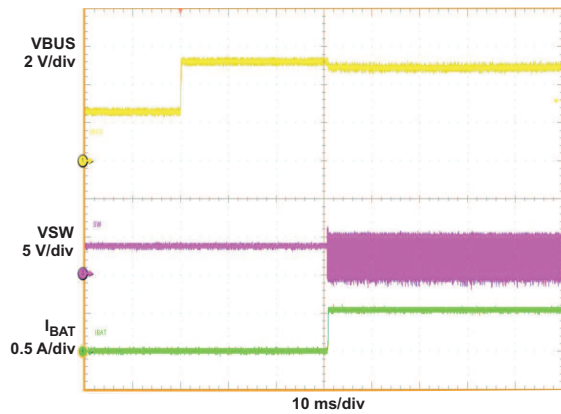

Figure 3. VBUS = 0-5V, lin_limit = 500mA, Voreg = 4.2V
VBAT = 3.5V, Ichg = 550mA, 32S mode

CYCLE BY CYCLE CURRENT LIMITING IN CHARGE MODE

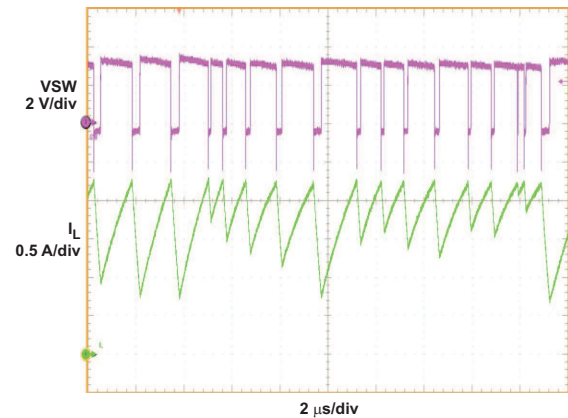

Figure 4. VBUS = 5V, VBAT = 3.5V
Charge Mode Overload Operation

BATTERY INSERTION/REMOVAL

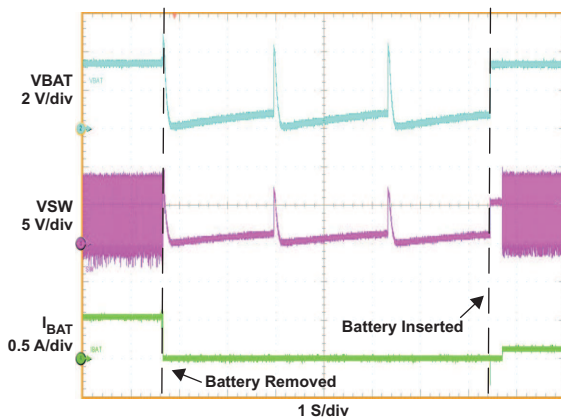

Figure 5. VBUS = 5 V, VBAT = 3.4V, lin_limit = 500 mA (32s Mode)

PWM CHARGING WAVEFORMS

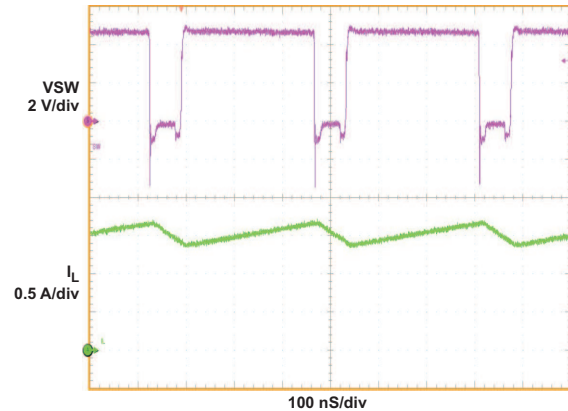

Figure 6. VBUS = 5 V, VBAT = 2.6 V, Voreg = 4.2 V, Ichg = 1550 mA

BATTERY DETECTION AT POWER UP (bq24153/6)

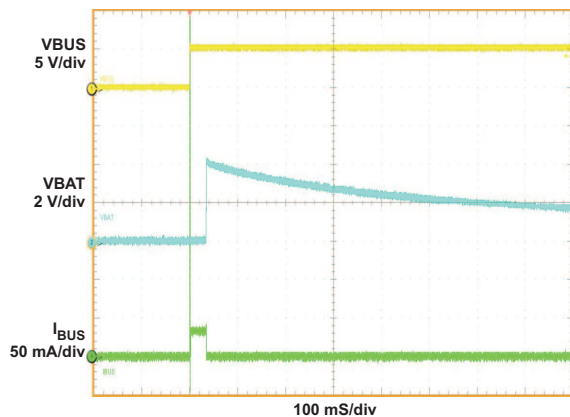

Figure 7. VBUS=5V, No battery connected

BATTERY DETECTION AT POWER UP (bq24158)

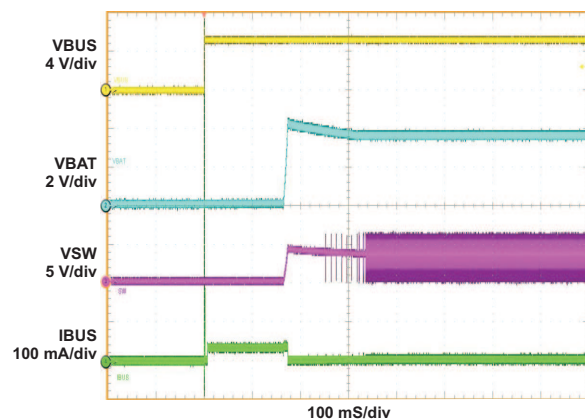

Figure 8. VBUS=5V, No battery connected

TYPICAL PERFORMANCE CHARACTERISTICS (continued)

POOR SOURCE DETECTION

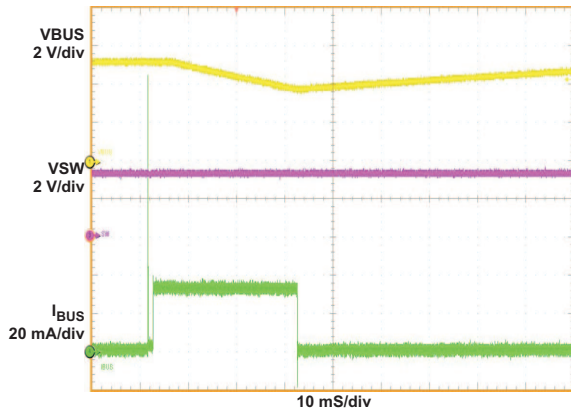

Figure 9. VBUS = 5 V @ 8 mA, VBAT = 3.2V, lin_limit = 100 mA, Ichg = 550 mA

CHARGE CURRENT RAMP UP

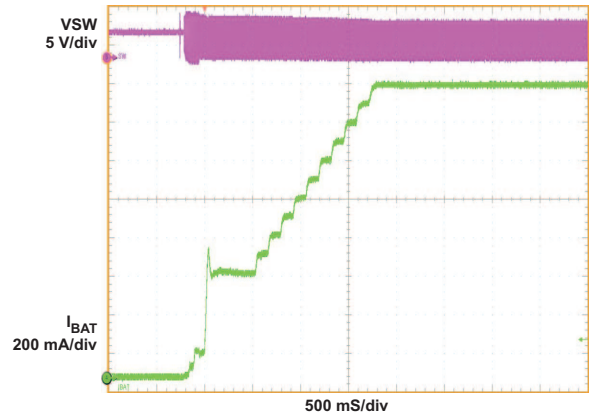

Figure 10. Vin = 5 V, Vbat = 3. 2V, No input current limit, ICHG=1550mA

INPUT CURRENT CONTROL (bq24153/8)

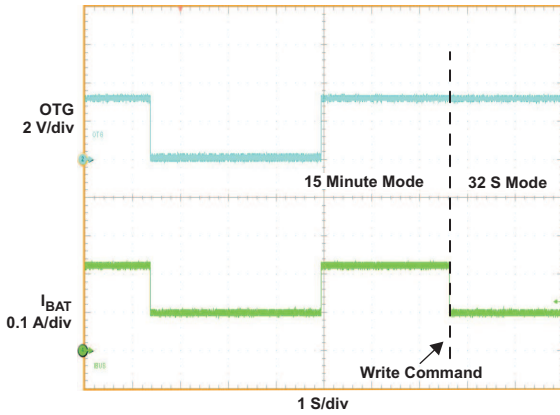

Figure 11. VBUS = 5 V, VBAT = 3.1V, lin_limit = 100/500 mA, (OTG control, 15 minute mode), lin_limit = 100 mA (I²C control, 32 second Mode)

VIN BASED DPM

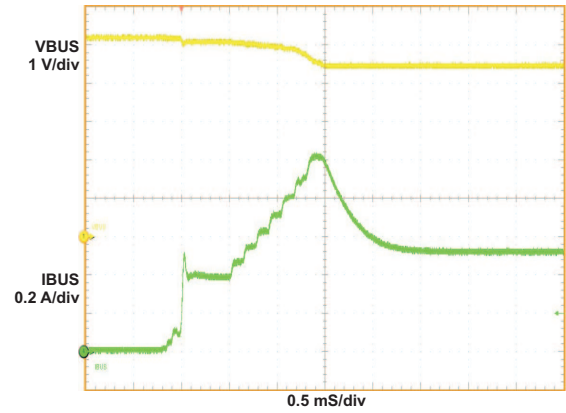

Figure 12. VBUS = 5 V @ 500 mA, VBAT = 3.5V, ICHG = 1550 mA, VIN_DPM = 4.52 V

CHARGER EFFICIENCY

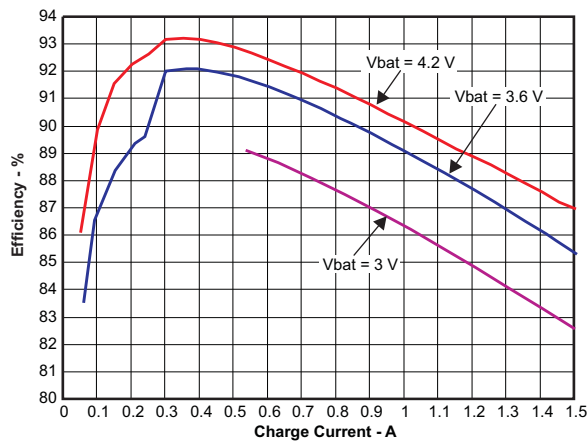

Figure 13.

BOOST WAVEFORM (PWM MODE)

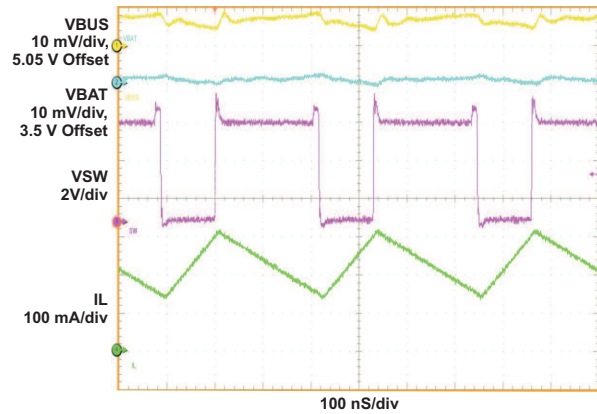

Figure 14. VBUS = 5.05 V, VBAT = 3.5V, IBUS = 217 mA

TYPICAL PERFORMANCE CHARACTERISTICS (continued)

BOOST WAVEFORM (PFM MODE)

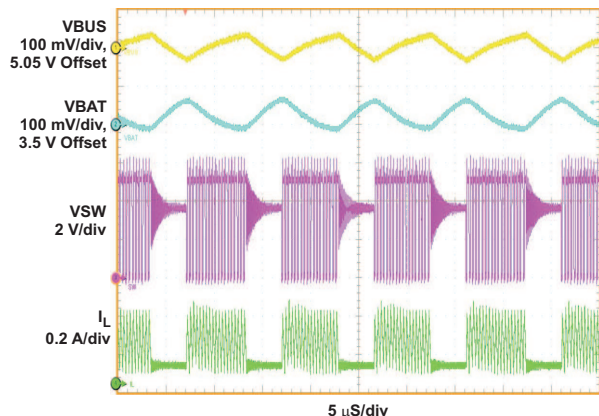

Figure 15. VBUS = 5.05 V, VBAT = 3.5V, I_{BUS} = 42 mA

VBUS OVERLOAD WAVEFORMS (BOOST MODE)

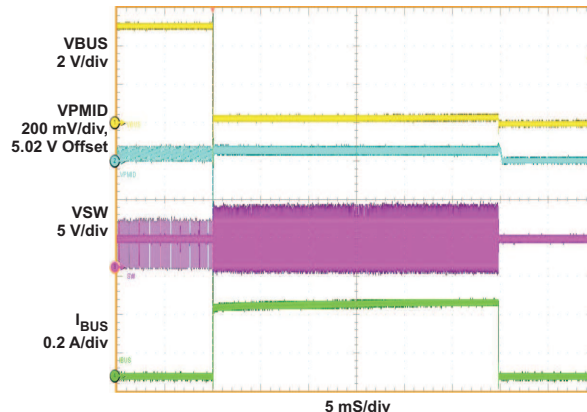

Figure 16. VBUS = 5.05 V, VBAT = 3.5V, R_{LOAD} (at VBUS)= 1KΩ to 0.5Ω

LOAD STEP UP RESPONSE (BOOST MODE)

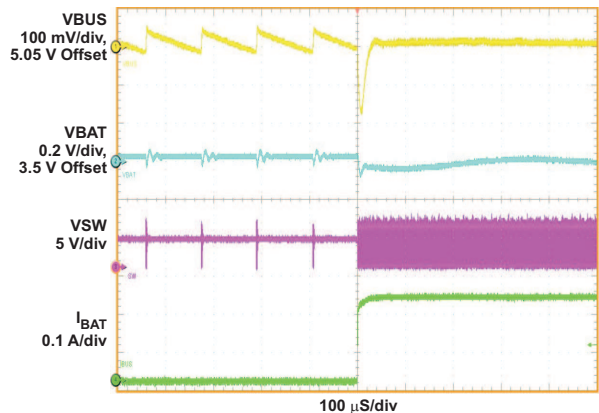

Figure 17. VBUS = 5.05 V, VBAT = 3.5V, I_{BUS} = 0-217 mA

LOAD STEP DOWN RESPONSE (BOOST MODE)

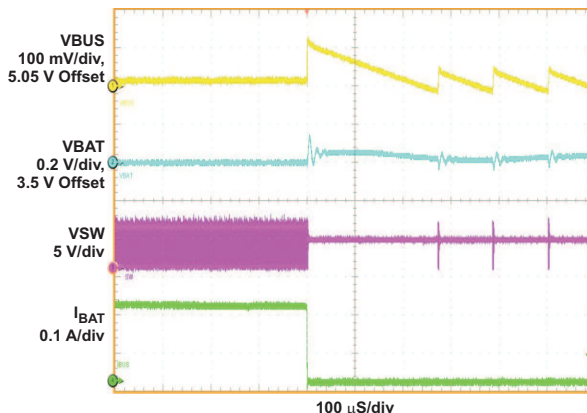

Figure 18. VBUS = 5.05 V, VBAT = 3.5V, I_{BUS} = 217 mA

BOOST TO CHARGE MODE TRANSITION (OTG CONTROL)

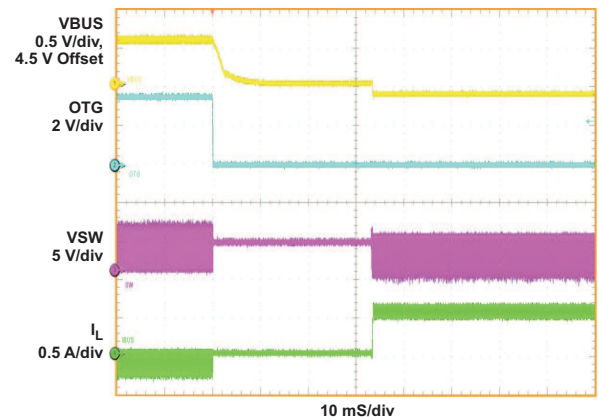

Figure 19. VBUS = 4.5 V (Charge Mode) / 5.1 V (Boost Mode), VBAT = 3.5V, I_{IN_LIM} = 500 mA, (32S mode)

BOOST EFFICIENCY

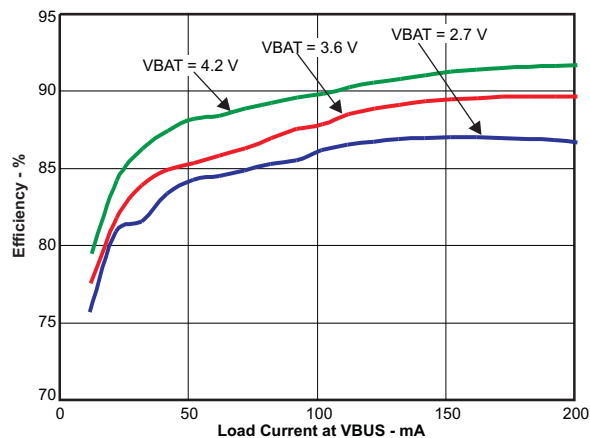

Figure 20.

TYPICAL PERFORMANCE CHARACTERISTICS (continued)

LINE REGULATION FOR BOOST

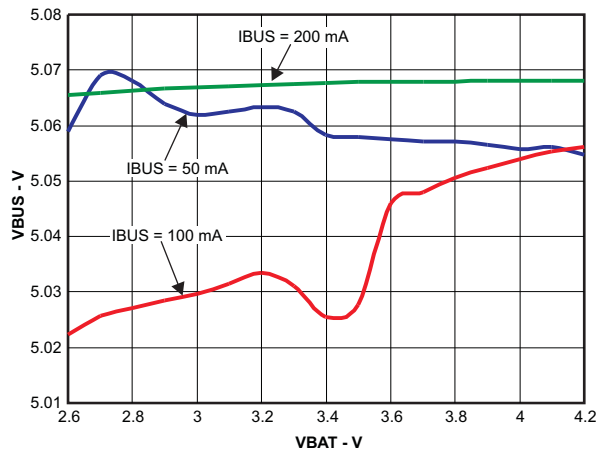

Figure 21.

LOAD REGULATION FOR BOOST

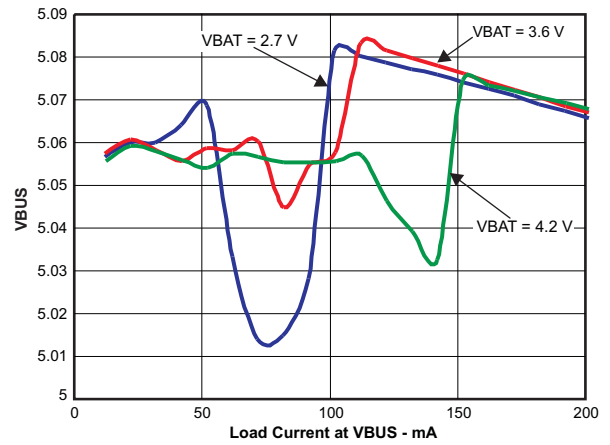

Figure 22.

FUNCTIONAL BLOCK DIAGRAM (Charge Mode)

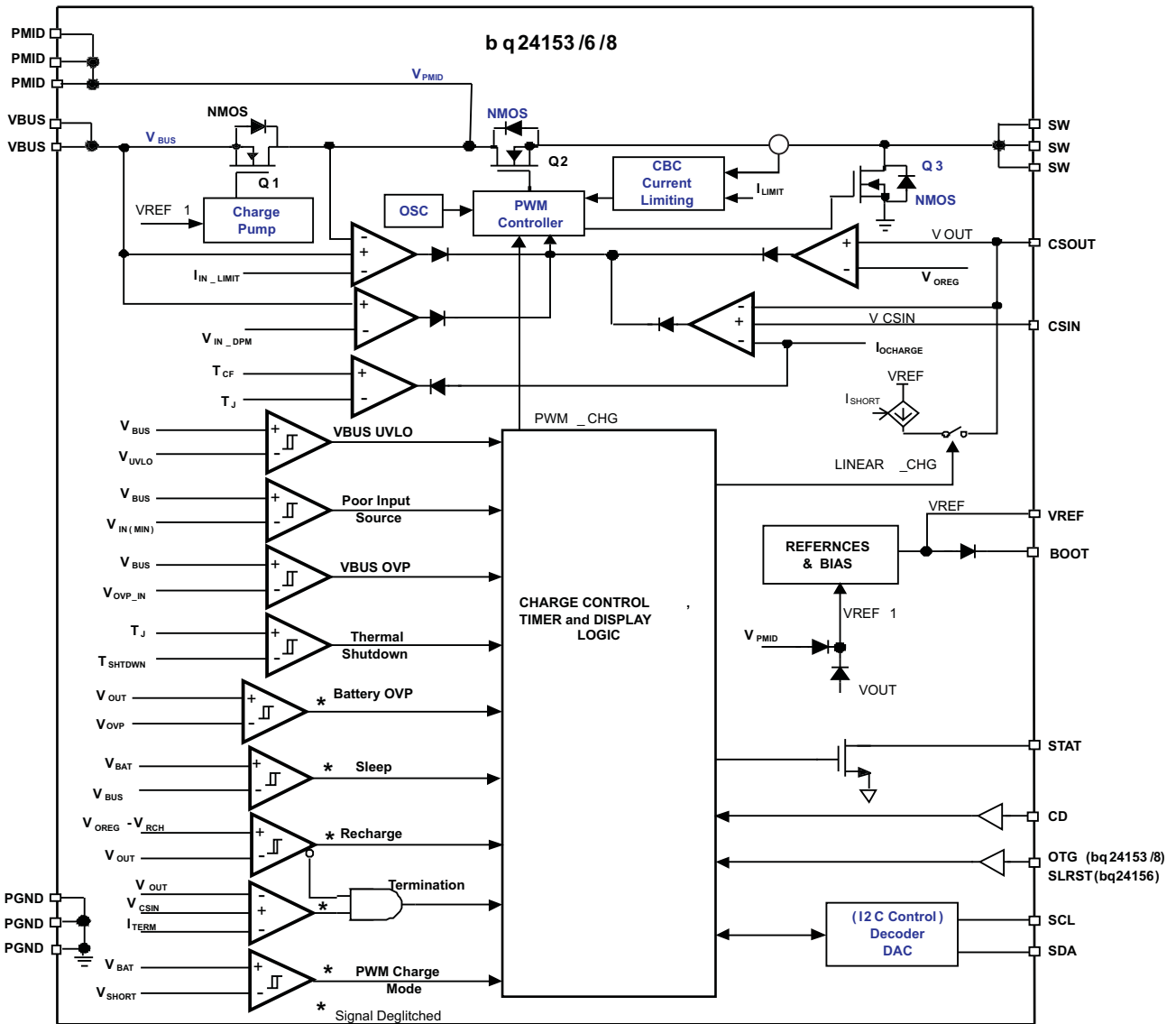

Figure 23. Function Block Diagram of bq2415x in Charge Mode

FUNCTIONAL BLOCK DIAGRAM (Boost Mode)

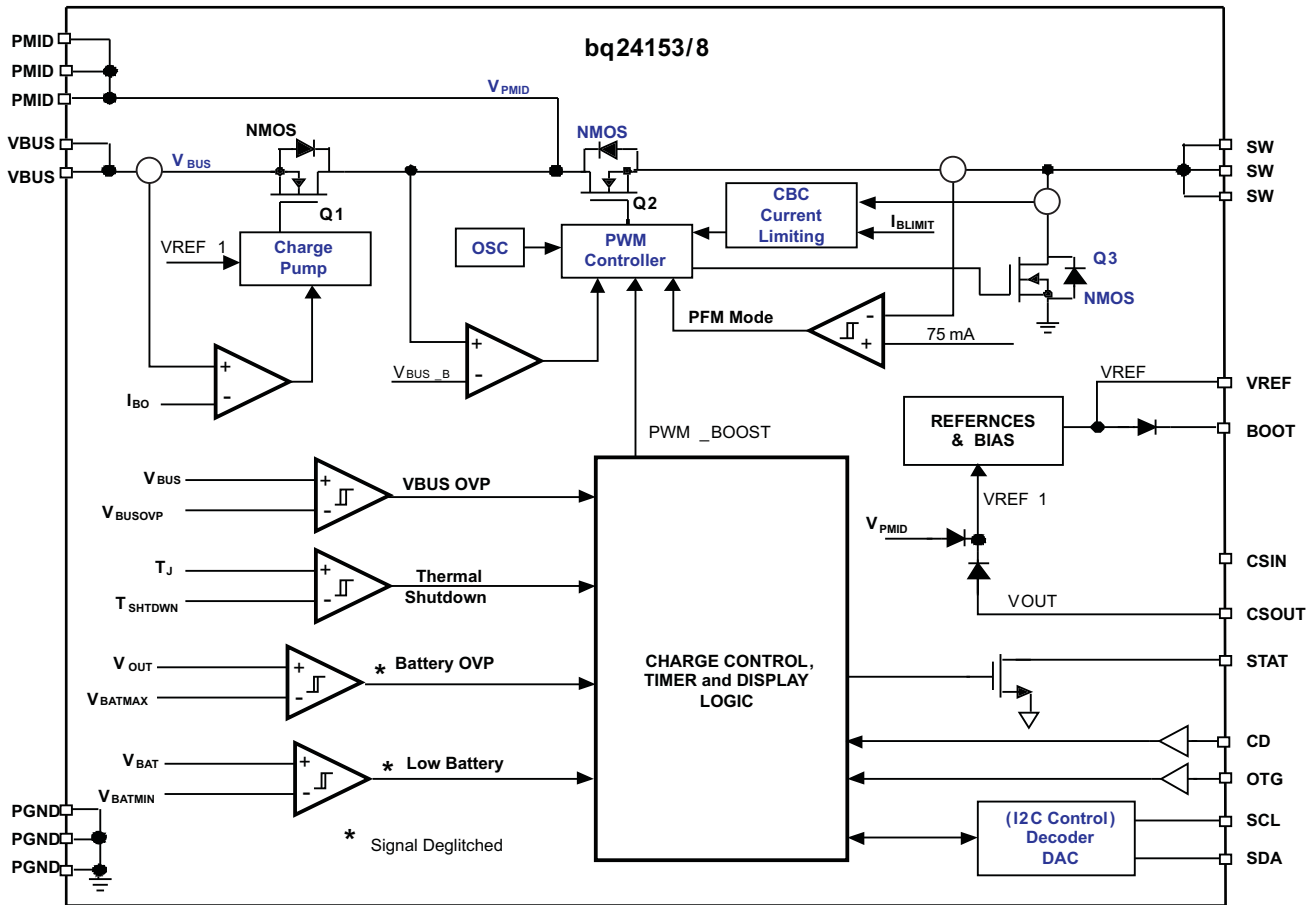

Figure 24. Function Block Diagram of bq2415x in Boost Mode

OPERATIONAL FLOW CHART

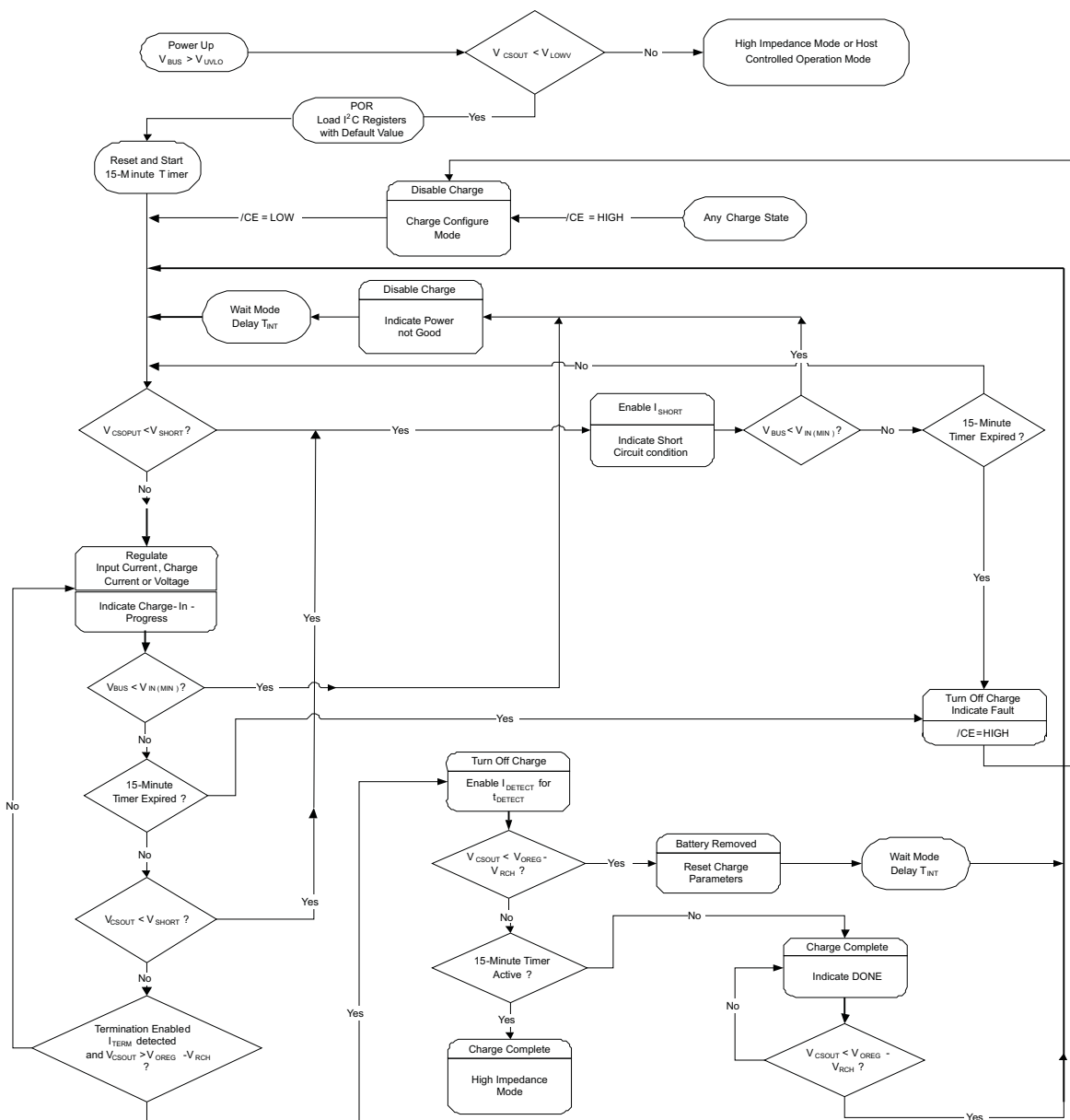

Figure 25. Operational Flow Chart of bq2415x in Charge Mode

DETAILED FUNCTIONAL DESCRIPTION

For a current restricted power source, such as a USB host or hub, a high efficiency converter is critical to fully use the input power capacity for quickly charging the battery. Due to the high efficiency for a wide range of input voltages and battery voltages, the switch mode charger is a good choice for high speed charging with less power loss and better thermal management than a linear charger.

The bq24153/6/8 are highly integrated synchronous switch-mode chargers, featuring integrated FETs and small external components, targeted at extremely space-limited portable applications powered by 1-cell Li-Ion or Li-polymer battery pack. Furthermore, bq24153/8 also has bi-directional operation to achieve boost function for USB OTG support.

The bq24153/8 have three operation modes: charge mode, boost mode, and high impedance mode, while bq24156 only has charge mode and high impedance mode. In charge mode, the IC supports a precision Li-ion or Li-polymer charging system for single-cell applications. In boost mode, the IC boosts the battery voltage to VBUS for powering attached OTG devices. In high impedance mode, the IC stops charging or boosting and operates in a mode with very low current from VBUS or battery, to effectively reduce the power consumption when the portable device is in standby mode. Through the proper control, the IC achieves the smooth transition among the different operation modes.

CHARGE MODE OPERATION

Charge Profile

In charge mode, the IC has five control loops to regulate input voltage, input current, charge current, charge voltage and device junction temperature. During the charging process, all five loops are enabled and the one that is dominant takes control. The IC supports a precision Li-ion or Li-polymer charging system for single-cell applications. [Figure 26 \(a\)](#) indicates a typical charge profile without input current regulation loop. It is the traditional CC/CV charge curve, while [Figure 26\(b\)](#) shows a typical charge profile when input current limiting loop is dominant during the constant current mode. In this case, the charge current is higher than the input current so the charge process is faster than the linear chargers. For bq24153/6/8, the input voltage threshold for DPM loop, input current limits, the charge current, termination current, and charge voltage are all programmable using I²C interface.

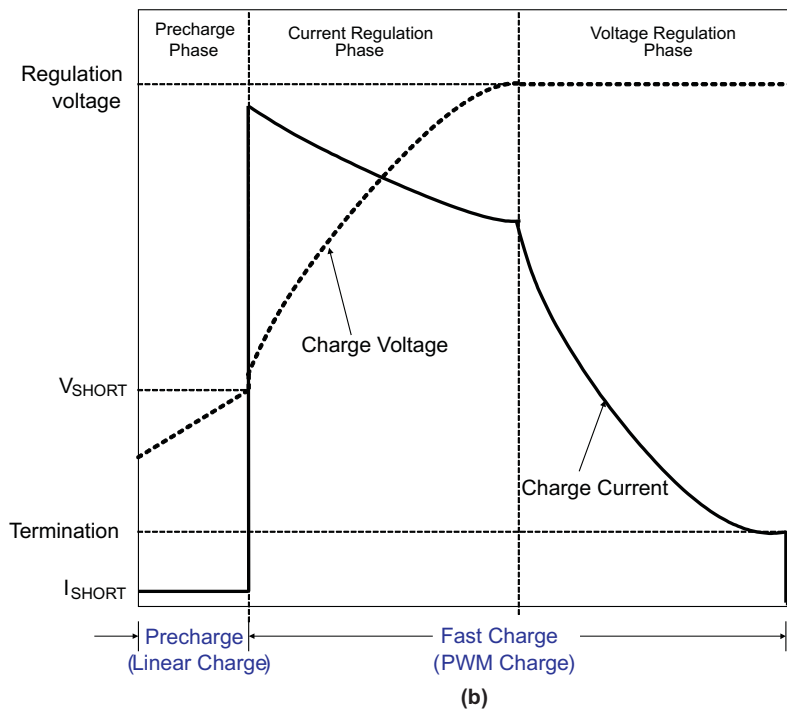
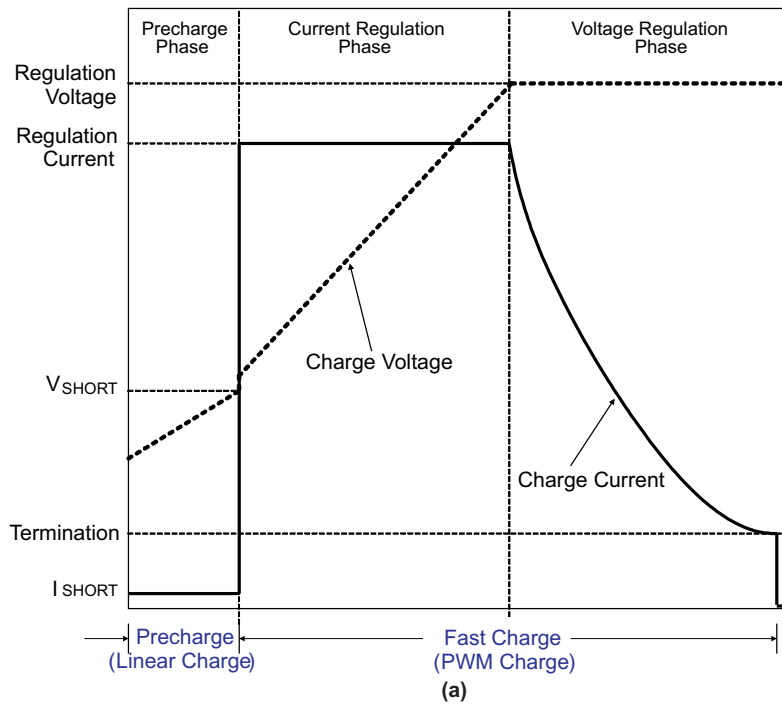

Figure 26. Typical Charging Profile of bq24153/6/8 for (a) without Input Current Limit, and (b) with Input Current Limit

PWM Controller in Charge Mode

The IC provides an integrated, fixed 3 MHz frequency voltage-mode controller to regulate charge current or voltage. This type of controller is used to improve line transient response, thereby, simplifying the compensation network used for both continuous and discontinuous current conduction operation. The voltage and current loops are internally compensated using a Type-III compensation scheme that provides enough phase margin for stable operation, allowing the use of small ceramic capacitors with very low ESR. The device operates between 0% to 99.5% duty cycles.

The IC has back to back common-drain N-channel FETs at the high side and one N-channel FET at low side. The input N-FET (Q1) prevents battery discharge when V_{BUS} is lower than V_{CSOUT}. The second high-side N-FET (Q2) is the switching control switch. A charge pump circuit is used to provide gate drive for Q1, while a bootstrap circuit with an external bootstrap capacitor is used to supply the gate drive voltage for Q2.

Cycle-by-cycle current limit is sensed through the FETs Q2 and Q3. The threshold for Q2 is set to a nominal 2.4-A peak current. The low-side FET (Q3) also has a current limit that decides if the PWM Controller will operate in synchronous or non-synchronous mode. This threshold is set to 100mA and it turns off the low-side N-channel FET (Q3) before the current reverses, preventing the battery from discharging. Synchronous operation is used when the current of the low-side FET is greater than 100mA to minimize power losses.

Battery Charging Process

At the beginning of precharge, while battery voltage is below the V_(SHORT) threshold, the IC applies a short-circuit current, I_(SHORT), to the battery.

When the battery voltage is above V_{SHORT} and below V_{OREG}, the charge current ramps up to fast charge current, I_{OCHARGE}, or a charge current that corresponds to the input current of I_{IN_LIMIT}. The slew rate for fast charge current is controlled to minimize the current and voltage over-shoot during transient. Both the input current limit, I_{IN_LIMIT}, and fast charge current, I_{OCHARGE}, can be set by the host. Once the battery voltage reaches the regulation voltage, V_{OREG}, the charge current is tapered down as shown in [Figure 26](#). The voltage regulation feedback occurs by monitoring the battery-pack voltage between the CSOUT and PGND pins. The regulation voltage is adjustable (3.5V to 4.44V) and is programmed through I²C interface.

The IC monitors the charging current during the voltage regulation phase. When the termination is enabled, once the termination threshold, I_{TERM}, is detected and the battery voltage is above the recharge threshold, the IC terminates charge. The termination current level is programmable. To disable the charge current termination, the host can set the charge termination bit (I_{Term}) of charge control register to 0, refer to I²C section for detail.

A new charge cycle is initiated when one of the following conditions is detected:

- The battery voltage falls below the V_(OREG) – V_(RCH) threshold.
- V_{BUS} Power-on reset (POR), if battery voltage is below the V_(LOWV) threshold.
- \overline{CE} bit toggle or RESET bit is set (Host controlled)

Safety Timer in Charge Mode

At the beginning of charging process, the IC starts a 15-minute timer (T15min) that can be disabled by any write-action performed by host through I²C interface. Once the 15-minute timer is disabled, a 32-second timer (T32sec) is automatically started. The 32-second timer can be reset by host using I²C interface. Writing “1” to reset bit of TMR_RST in control register will reset the 32-second timer and TMR_RST is automatically set to “0” after the 32-second timer is reset. If the 32-second timer expires, the charge is terminated and charge parameters are reset to default values. Then the 15-minute timer starts and the charge resumes.

During normal charging process, the IC is usually in 32-second mode with host control and 15-minute mode without host control using I²C interface. The above process repeats until the battery is fully charged. If the 15-minute timer expires, the IC turns off the charge, enunciates FAULT on the STATx bits of status register, and sends the 128μs interrupt pulse. This function prevents battery over charge if the host fails to reset the safety timer. The 15-minute charge, with default parameters, allows time for a discharged battery to charge sufficiently to be able to power the host and start communication. The safety timer flow chart is shown in [Figure 27](#). Fault condition is cleared by POR and fault status bits can only be updated after the status bits are read by the host.

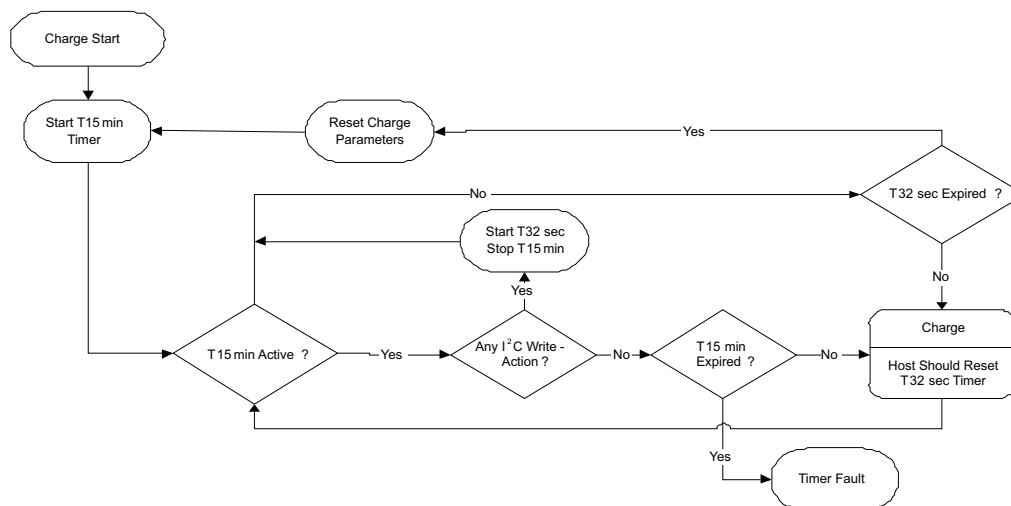

Figure 27. Timer Flow Chart for bq24153/6/8

USB Friendly Boot-Up Sequence

Prior to power up if the host continues to write the TMR_RST bit to 1, to stay in 32 second mode, on power up the charger enters normal charge mode (using the desired control bits). If not in 32 second mode at power up, the charge will operate with default bit values, in 15 minute mode, until the host updates the control registers.

If the battery voltage is above the V_{LOWV} threshold while in 15 minute mode, the charger will be in the high impedance state. The default control bits set the charging current and regulation voltage low as a safety feature to avoid violating USB spec and over-charging any of the Li-Ion chemistries, while the host has lost communication. The input current limiting is described below.

Input Current Limiting

The input current sensing circuit and control loop are integrated into the IC. When operating in 15 minute mode, for bq24153/8, the OTG pin sets the input current limit to 100mA for a logic low and 500mA for a logic high, whereas the bq24156 defaults to 500mA. In 32 second mode, the input current limit is set by the programmed control bits in register 01H.

Thermal Regulation and Protection

To prevent overheat of the chip during the charging process, the IC monitors the junction temperature, T_J , of the die and begins to taper down the charge current once T_J reaches the thermal regulation threshold, T_{CF} . The charge current is reduced to zero when the junction temperature increases approximately 10°C above T_{CF} . In any state, if T_J exceeds T_{SHTDWN} , the IC suspends charging. In thermal shutdown mode, PWM is turned off and all timers are frozen. Charging resumes when T_J falls below T_{SHTDWN} by approximately 10°C .

Input Voltage Protection in Charge Mode

Sleep Mode

The IC enters the low-power sleep mode if the voltage on V_{BUS} pin falls below sleep-mode entry threshold, $V_{CSOUT}+V_{SLP}$, and V_{BUS} is higher than the bad adaptor detection threshold, $V_{IN(MIN)}$. This feature prevents draining the battery during the absence of V_{BUS} . During sleep mode, both the reverse blocking switch Q1 and PWM are turned off.

Bad Adaptor Detection/Rejection

At the POR of VBUS, the IC performs the bad adaptor detection by applying a current sink to VBUS. If the VBUS is higher than $V_{IN(MIN)}$ for 30ms, the adaptor is good and the charge process begins. Otherwise, if the VBUS drops below $V_{IN(MIN)}$, the bad adaptor is detected. Then, the IC disables the current sink, sends a send fault pulse in FAULT pin and sets the bad adaptor flag (B2-B0=011 for Register 00H). After a delay of T_{INT} , the IC repeats the adaptor detection process, as shown in Figure 28 and Figure 29.

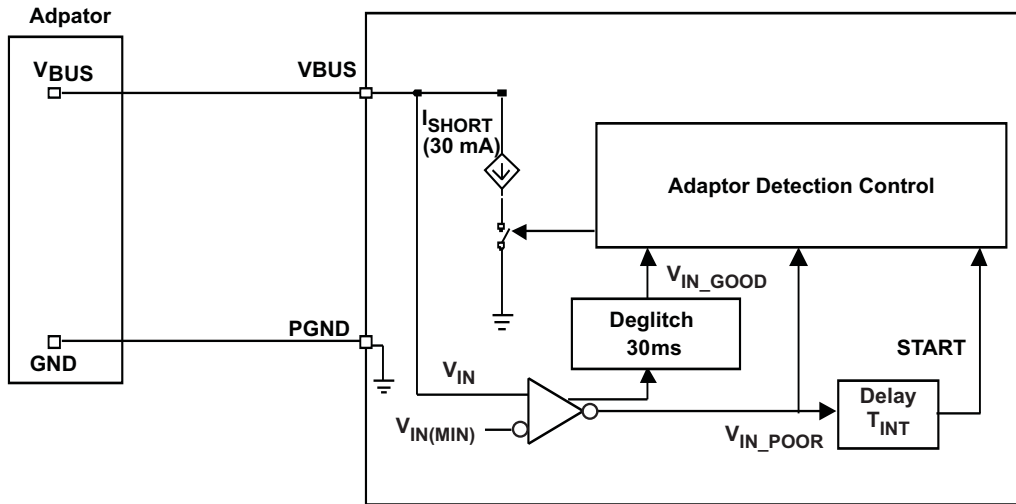

Figure 28. Bad Adaptor Detection Circuit

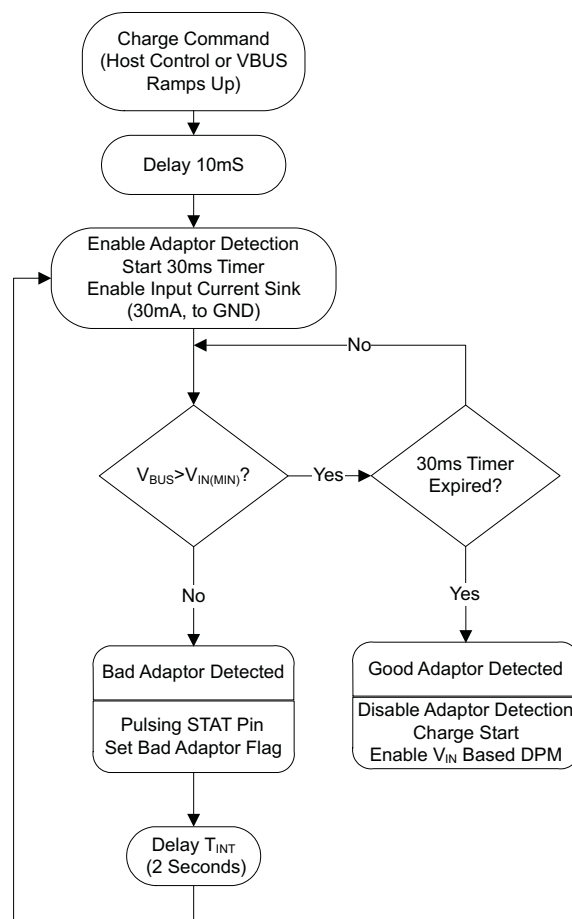

Figure 29. Bad Adaptor Detection Scheme FLOW Chart

Input Voltage Based DPM (Special charger identification)

During the charging process, if the input power source is not able to support the programmed or default charging current, VBUS voltage will decrease. Once the VBUS drops to V_{IN_DPM} (default 4.52V), the charge current begins to taper down to prevent the further drop of VBUS. When the IC enters this mode, the charge current is lower than the set value and the special charger bit is set (B4 in Register 05H). This feature will make the IC compatible with adapters with different current capabilities.

Input Over-Voltage Protection

The IC provides a built-in input over-voltage protection to protect the device and other components against damage if the input voltage (Voltage from V_{BUS} to PGND) goes too high. When an input over-voltage condition is detected, the IC turns off the PWM converter, sets fault status bits, and sends out a fault pulse from the STAT pin. Once V_{BUS} drops below the input over-voltage exit threshold, the fault is cleared and charge process resumes.

Battery Protection in Charge Mode

Output Over-Voltage Protection

The IC provides a built-in over-voltage protection to protect the device and other components against damage if the battery voltage goes too high, as when the battery is suddenly removed. When an over-voltage condition is detected, the IC turns off the PWM converter, sets fault status bits, and sends out a fault pulse from the STAT pin. Once V_{CSOUT} drops to the battery over-voltage exit threshold, the fault is cleared and charge process resumes.

Battery Detection During Normal Charging

For applications with removable battery packs, the IC provides a battery absent detection scheme to reliably detect insertion or removal of battery packs.

During normal charging process with host control, once the voltage at the CSOUT pin is above the battery recharge threshold, $V_{OREG} - V_{RCH}$, and the termination charge current is detected, the IC turns off the PWM charge and enables a discharge current, I_{DETECT} , for a period of t_{DETECT} , then checks the battery voltage. If the battery voltage is still above recharge threshold, the battery is present and the charge done is detected. On the other hand, if the battery voltage is below battery recharge threshold, the battery is absent. Under this condition, the charge parameters (such as input current limit) are reset to the default values and charge resumes after a delay of T_{INT} . This function ensures that the charge parameters are reset whenever the battery is replaced.

Battery Detection at Power Up

bq24153/6 also has a unique battery detection scheme during the start up of the charger. At VBUS power up, if the timer is in 15-minute mode, bq24153/6 will start a 32ms timer when exiting from short circuit mode to PWM charge mode. If the battery voltage is charged to recharge threshold ($V_{OREG} - V_{RCH}$) and the 32ms timer is not expired yet, or battery voltage is above output OVP threshold during short-circuit mode, bq24153/6 will consider that the battery is not present; then stop charging and go to high impedance mode immediately. However, if the 32ms timer is expired before the recharge threshold is reached, the charging process will continue as normal battery charging process. For bq24158, the 32ms timer for battery detection at power up is disabled. Therefore, bq24158 can power up the system without a battery.

Battery Short Protection

During the normal charging process, if the battery voltage is lower than the short-circuit threshold, V_{SHORT} , the charger operates in short circuit mode with a lower charge rate of I_{SHORT} .

Charge Status Output, STAT Pin

The STAT pin is used to indicate operation conditions for bq24153/6/8. STAT is pulled low during charging when EN_STAT bit in control register (00H) is set to “1”. Under other conditions, STAT pin behaves as a high impedance (open-drain) output. Under fault conditions, a 128- μ s pulse will be sent out to notify the host. The status of STAT pin at different operation conditions is summarized in [Table 1](#). The STAT pin can be used to drive an LED or communicate to the host processor.

Table 1. STAT Pin Summary

CHARGE STATE	STAT
Charge in progress and EN_STAT=1	Low
Other normal conditions	Open-drain
Charge mode faults: Timer fault, sleep mode, VBUS or battery overvoltage, poor input source, VBUS UVLO, no battery, thermal shutdown	128- μ s pulse, then open-drain
Boost mode faults (bq24153/8 only): Timer fault, over load, VBUS or battery overvoltage, low battery voltage, thermal shutdown	128- μ s pulse, then open-drain

Control Bits in Charge Mode

\overline{CE} Bit (Charge Mode)

The \overline{CE} bit in the control register is used to disable or enable the charge process. A low logic level (0) on this bit enables the charge and a high logic level (1) disables the charge.

RESET Bit

The RESET bit in the control register is used to reset all the charge parameters. Write ‘1’ to RESET bit will reset all the charge parameters to default values except safety limit register, and RESET bit is automatically cleared to zero once the charge parameters get reset. It is designed for charge parameter reset before charge starts and it is not recommended to set RESET bit when charging or boosting in progress.

OPA_Mode Bit

OPA_MODE is the operation mode control bit. When OPA_MODE = 0, the IC operates as a charger if HZ_MODE is set to "0", refer to [Table 2](#) for detail. When OPA_MODE=1 and HZ_MODE=0, the IC operates in boost mode.

Table 2. Operation Mode Summary

OPA_MODE	HZ_MODE	OPERATION MODE
0	0	Charge (no fault) Charge configure (fault, $V_{bus} > V_{UVLO}$) High impedance ($V_{bus} < V_{UVLO}$)
1(bq24153/8 only)	0	Boost (no faults) Any fault go to charge configure mode
X	1	High impedance

Control Pins in Charge Mode

CD Pin (Charge Disable)

The CD pin is used to disabled the charging process. When CD=0, charge is enabled. When CD=1, charge is disabled and VBUS pin is high impedance to GND. In 15-minute mode, setting CD=1 resets the 15-minute timer; while in 32s mode, setting CD=1 does NOT reset the 32-second timer.

SLRST Pin (Safety Limit Register 06H Reset, bq24156 only)

When SLRST=0, bq24156 will reset all the safety limits to default values, regardless of the write actions to safety limits registers (06H). When SLRST=1, bq24156 can program the safety limit register until any write action to other registers locks the programmed safety limits.

Boost Mode Operation (bq24153/8 only)

In 32 second mode, when OTG pin is in active status or the bit of operation mode (OPA_MODE) at control register is set to 1, bq24153/8 operates in boost mode and delivers the power to VBUS from the battery. In normal boost mode, bq24153/8 converts the battery voltage to V_{BUS-B} (about 5.05V) and delivers a current as much as I_{B0} (about 200mA) to support other USB OTG devices connected to the USB connector.

PWM Controller in Boost Mode

Similar to charge mode operation, in boost mode, the IC provides an integrated, fixed 3 MHz frequency voltage-mode controller to regulate output voltage at PMID pin (V_{PMID}). The voltage control loop is internally compensated using a Type-III compensation scheme that provides enough phase margin for stable operation with a wide load range and battery voltage range.

In boost mode, the input N-FET (Q1) prevents battery discharge when VBUS pin is over loaded. Cycle-by-cycle current limit is sensed through the internal sense FET for Q3. The cycle-by-cycle current limit threshold for Q3 is set to a nominal 1.0-A peak current. Synchronous operation is used in PWM mode to minimize power losses.

Boost Start Up

To prevent the inductor saturation and limit the inrush current, a soft-start control is applied during the boost start up.

PFM Mode at Light Load

In boost mode, the IC operates in pulse skipping mode (PFM mode) to reduce the power loss and improve the converter efficiency at light load condition. During boosting, the PWM converter is turned off once the inductor current is less than 75mA; and the PWM is turned back on only when the voltage at PMID pin drops to about 99.5% of the rated output voltage. A unique pre-set circuit is used to make the smooth transition between PWM and PFM mode.

Safety Timer in Boost Mode

At the beginning of boost operation, the IC starts a 32-second timer that is reset by the host using the I²C interface. Writing “1” to reset bit of TMR_RST in control register will reset the 32-second timer and TMR_RST is automatically set to “0” after the 32-second timer is reset. Once the 32-second timer expires, the IC turns off boost converter, enunciates the fault pulse from the STAT pin and sets fault status bits in the status register. The fault condition is cleared by POR or host control.

Protection in Boost Mode

Output Overvoltage Protection

The IC provides a built-in over-voltage protection to protect the device and other components against damage if the VBUS voltage goes too high. When an over-voltage condition is detected, the IC turns off the PWM converter, resets OPA_MODE bit to 0, sets fault status bits, and sends out a fault pulse from the STAT pin. Once VBUS drops to the normal level, the boost starts after host sets OPA_MODE to “1” or OTG pin stays in active status.

Output Overload Protection

The IC provides a built-in over-load protection to prevent the device and battery from damage when VBUS is over loaded. Once over load condition is detected, Q1 will operate in linear mode to limit the output current while VPMID keeps in voltage regulation. If the over load condition lasts for more than 30ms, the over-load fault is detected. When an over-load condition is detected, the IC turns off the PWM converter, resets OPA_MODE bit to 0, sets fault status bits and sends out fault pulse in STAT pin. The boost will not start until the host clears the fault register.

Battery Overvoltage Protection

During boosting, when battery voltage is above the battery over voltage threshold, V_{BATMAX} , or below the minimum battery voltage threshold, V_{BATMIN} , the IC will turn off the PWM converter, resets OPA_MODE bit to 0, sets fault status bits and sends out fault pulse in STAT pin. Once the battery voltage goes above V_{BATMIN} , the boost will start after the host sets OPA_MODE to “1” or OTG pin stays in active status.

STAT Pin Boost Mode

During normal boosting process, the STAT pin behaves as a high impedance (open-drain) output. Under fault conditions, a 128- μ s pulse is sent out to notify the host.

High Impedance Mode

When control bit of HZ-MODE is set to “1” and OTG pin is not in active status, the IC operates in high impedance mode, with the input impedance of the VBUS pin to be higher than 217k Ω . In high impedance mode, a low power 32-second timer will be enabled when the battery voltage is below V_{LOWV} to monitor if the host control is available or not. If the low power 32 second timer expires, the IC operates in 15 minute mode and the low power 32 second timer is disabled. In 15 minute mode, when VBUS is below V_{UVLO} , the IC operates in high impedance mode regardless of the setting of the HZ_MODE bit.

SERIAL INTERFACE DESCRIPTION

I²C is a 2-wire serial interface developed by Philips Semiconductor (see I²C-Bus Specification, Version 2.1, January 2000). The bus consists of a data line (SDA) and a clock line (SCL) with pull-up structures. When the bus is idle, both SDA and SCL lines are pulled high. All the I²C compatible devices connect to the I²C bus through open drain I/O pins, SDA and SCL. A master device, usually a microcontroller or a digital signal processor, controls the bus. The master is responsible for generating the SCL signal and device addresses. The master also generates specific conditions that indicate the START and STOP of data transfer. A slave device receives and/or transmits data on the bus under control of the master device.

The IC works as a slave and is compatible with the following data transfer modes, as defined in the I²C-Bus Specification: standard mode (100 kbps), fast mode (400 kbps), and high-speed mode (up to 3.4 Mbps in write

mode). The interface adds flexibility to the battery charge solution, enabling most functions to be programmed to new values depending on the instantaneous application requirements. Register contents remain intact as long as supply voltage remains above 2.2 V (typical). I²C is asynchronous, which means that it runs off of SCL. The device has no noise or glitch filtering on SCL, so SCL input needs to be clean. Therefore, it is recommended that SDA changes while SCL is LOW.

The data transfer protocol for standard and fast modes is exactly the same, therefore, they are referred to as F/S-mode in this document. The protocol for high-speed mode is different from the F/S-mode, and it is referred to as HS-mode. The bq24150/1 device supports 7-bit addressing only. The device 7-bit address is defined as '1101011' (6BH) for bq24153, and '1101010' (6AH) for bq24156/8.

F/S Mode Protocol

The master initiates data transfer by generating a start condition. The start condition is when a high-to-low transition occurs on the SDA line while SCL is high, as shown in Figure 30. All I²C-compatible devices should recognize a start condition.

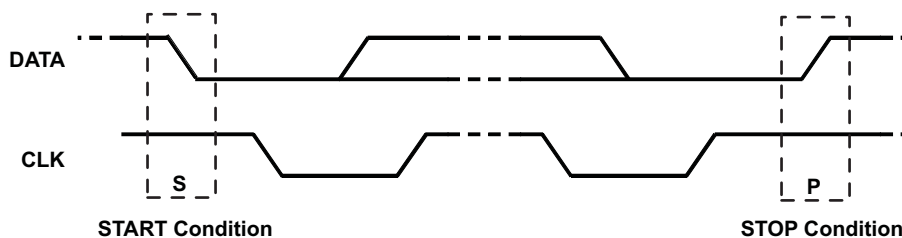

Figure 30. START and STOP Condition

The master then generates the SCL pulses, and transmits the 8-bit address and the read/write direction bit R/W on the SDA line. During all transmissions, the master ensures that data is valid. A valid data condition requires the SDA line to be stable during the entire high period of the clock pulse (see Figure 31). All devices recognize the address sent by the master and compare it to their internal fixed addresses. Only the slave device with a matching address generates an acknowledge (see Figure 31) by pulling the SDA line low during the entire high period of the ninth SCL cycle. Upon detecting this acknowledge, the master knows that communication link with a slave has been established.

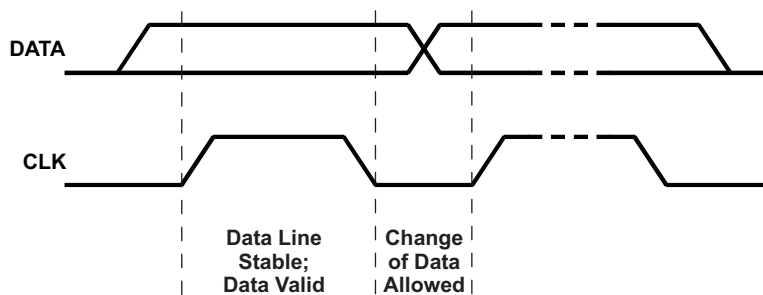

Figure 31. Bit Transfer on the Serial Interface

The master generates further SCL cycles to either transmit data to the slave (R/W bit 1) or receive data from the slave (R/W bit 0). In either case, the receiver needs to acknowledge the data sent by the transmitter. So an acknowledge signal can either be generated by the master or by the slave, depending on which one is the receiver. The 9-bit valid data sequences consisting of 8-bit data and 1-bit acknowledge can continue as long as necessary. To signal the end of the data transfer, the master generates a stop condition by pulling the SDA line from low to high while the SCL line is high (see Figure 33). This releases the bus and stops the communication link with the addressed slave. All I²C compatible devices must recognize the stop condition. Upon the receipt of a stop condition, all devices know that the bus is released, and they wait for a start condition followed by a matching address. If a transaction is terminated prematurely, the master needs to send a STOP condition to prevent the slave I²C logic from getting stuck in a bad state. Attempting to read data from register addresses not listed in this section will result in FFh being read out.

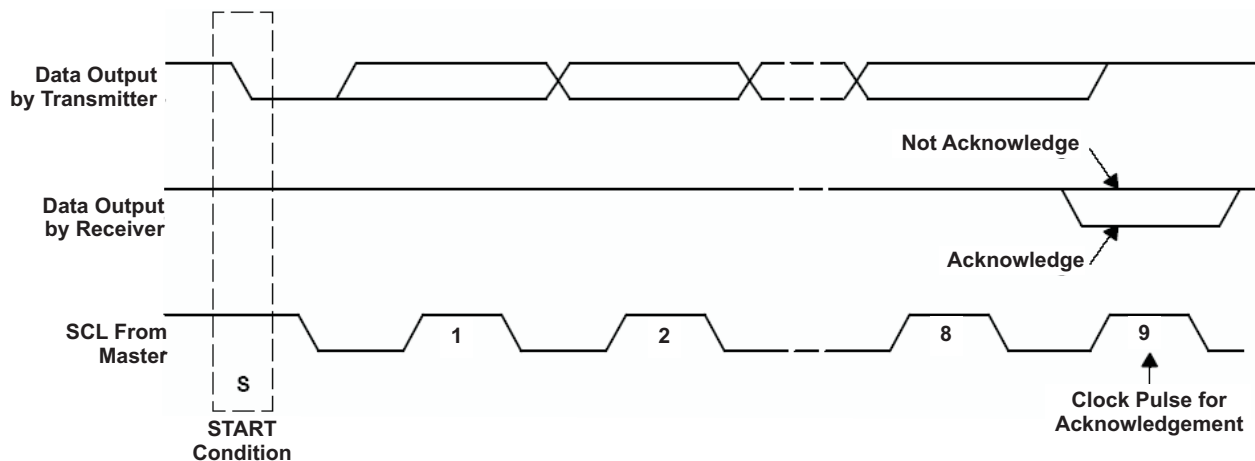

Figure 32. Acknowledge on the I²C Bus™

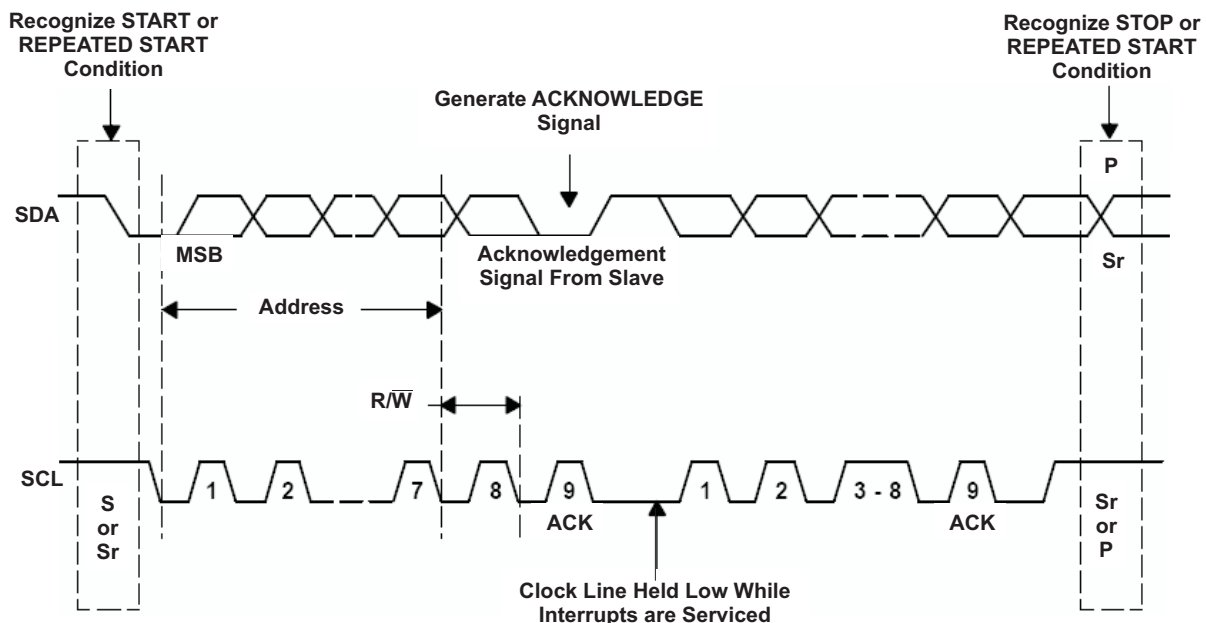

Figure 33. Bus Protocol

H/S Mode Protocol

When the bus is idle, both SDA and SCL lines are pulled high by the pull-up devices.

The master generates a start condition followed by a valid serial byte containing HS master code 00001XXX. This transmission is made in F/S-mode at no more than 400 Kbps. No device is allowed to acknowledge the HS master code, but all devices must recognize it and switch their internal setting to support 3.4-Mbps operation.

The master then generates a repeated start condition (a repeated start condition has the same timing as the start condition). After this repeated start condition, the protocol is the same as F/S-mode, except that transmission speeds up to 3.4 Mbps are allowed. A stop condition ends the HS-mode and switches all the internal settings of the slave devices to support the F/S-mode. Instead of using a stop condition, repeated start conditions should be used to secure the bus in HS-mode. If a transaction is terminated prematurely, the master needs sending a STOP condition to prevent the slave I2C logic from getting stuck in a bad state.

Attempting to read data from register addresses not listed in this section results in FFh being read out.

I²C Update Sequence

The IC requires a start condition, a valid I²C address, a register address byte, and a data byte for a single update. After the receipt of each byte, the IC acknowledges by pulling the SDA line low during the high period of a single clock pulse. A valid I²C address selects the IC. The IC performs an update on the falling edge of the acknowledge signal that follows the LSB byte.

For the first update, the IC requires a start condition, a valid I²C address, a register address byte, a data byte. For all consecutive updates, The IC needs a register address byte, and a data byte. Once a stop condition is received, the IC releases the I²C bus, and awaits a new start conditions.

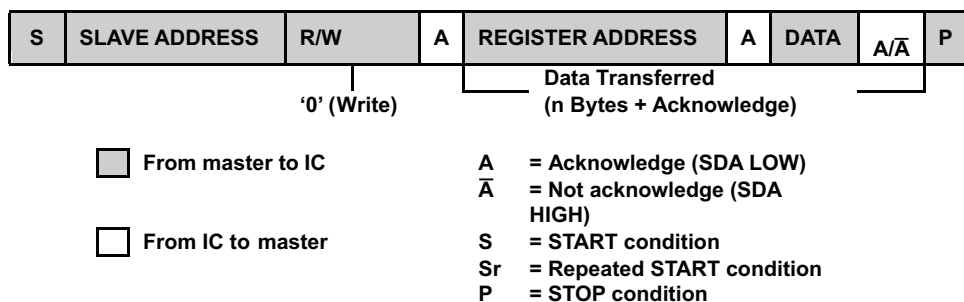

(a) F/S-Mode

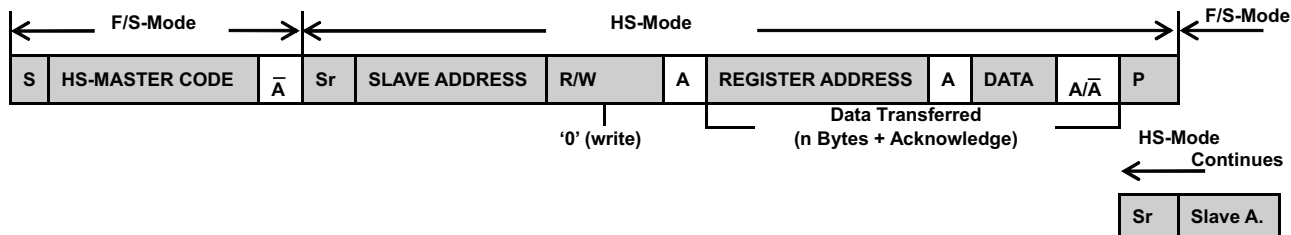

(b) HS-Mode

Figure 34. Data Transfer Format in F/S Mode and H/S Mode

Slave Address Byte

MSB							LSB
X	1	1	0	1	0	1	1

The slave address byte is the first byte received following the START condition from the master device.

Register Address Byte

MSB							LSB
0	0	0	0	0	D2	D1	D0

Following the successful acknowledgment of the slave address, the bus master will send a byte to the IC, which contains the address of the register to be accessed. The IC contains five 8-bit registers accessible via a bidirectional I²C-bus interface. Among them, four internal registers have read and write access; and one has only read access.

REGISTER DESCRIPTION

Table 3. Status/Control Register (Read/Write)
Memory Location: 00, Reset State: x1xx 0xxx

BIT	NAME	READ/WRITE	FUNCTION
B7 (MSB)	TMR_RST/OTG	Read/Write	Write: TMR_RST function, write "1" to reset the safety timer (auto clear) Read: OTG pin status, (for bq24153/8 only) 0-OTG pin at Low level, 1-OTG pin at High level SLRST pin status (for bq2156 only), 0-SLRST pin at LOW level, 1-SLRST pin at HIGH level.
B6	EN_STAT	Read/Write	0-Disable STAT pin function, 1-Enable STAT pin function (default 1)
B5	STAT2	Read Only	00-Ready, 01-Charge in progress, 10-Charge done, 11-Fault
B4	STAT1	Read Only	
B3	BOOST	Read Only	1-Boost mode, 0-Not in boost mode, for bq24153/8/9 only; NA—for bq24156.
B2	FAULT_3	Read Only	Charge mode: 000-Normal, 001-VBUS OVP, 010-Sleep mode, 011-Bad Adaptor or $V_{BUS} < V_{UVLO}$, 100-Output OVP, 101-Thermal shutdown, 110-Timer fault, 111-No battery
B1	FAULT_2	Read Only	
B0 (LSB)	FAULT_1	Read Only	Boost mode (for bq24153/8 only): 000-Normal, 001-VBUS OVP, 010-Over load, 011-Battery voltage is too low, 100-Battery OVP, 101-Thermal shutdown, 110-Timer fault, 111-NA

Table 4. Control Register (Read/Write)
Memory Location: 01, Reset State: 0011 0000

BIT	NAME	READ/WRITE	FUNCTION
B7 (MSB)	lin_Limit_2	Read/Write	00-USB host with 100-mA current limit, 01-USB host with 500-mA current limit, 10-USB host/charger with 800-mA current limit, 11-No input current limit (default 00 for bq24153/8, default 01 for bq24156)
B6	lin_Limit_1	Read/Write	
B5	$V_{(LOWV_2)}$ ⁽¹⁾	Read/Write	Weak battery voltage threshold: 200mV step (default 1)
B4	$V_{(LOWV_1)}$ ⁽¹⁾	Read/Write	Weak battery voltage threshold: 100mV step (default 1)
B3	TE	Read/Write	1-Enable charge current termination, 0-Disable charge current termination (default 0)
B2	\overline{CE}	Read/Write	1-Charger is disabled, 0-Charger enabled (default 0)
B1	HZ_MODE	Read/Write	1-High impedance mode, 0-Not high impedance mode (default 0)
B0 (LSB)	OPA_MODE	Read/Write	1-Boost mode, 0-Charger mode (default 0), for bq24153/8 only; NA—for bq24156.

(1) The range of the weak battery voltage threshold ($V_{(LOWV)}$) is 3.4 V to 3.7 V with an offset of 3.4 V and steps of 100 mV (default 3.7 V, using bits B4-B5).

Table 5. Control/Battery Voltage Register (Read/Write)
Memory Location: 02, Reset State: 0000 1010

BIT	NAME	READ/WRITE	FUNCTION
B7 (MSB)	$V_{O(REG5)}$	Read/Write	Battery Regulation Voltage: 640 mV step (default 0)
B6	$V_{O(REG4)}$	Read/Write	Battery Regulation Voltage: 320 mV step (default 0)
B5	$V_{O(REG3)}$	Read/Write	Battery Regulation Voltage: 160 mV step (default 0)
B4	$V_{O(REG2)}$	Read/Write	Battery Regulation Voltage: 80 mV step (default 0)
B3	$V_{O(REG1)}$	Read/Write	Battery Regulation Voltage: 40 mV step (default 1)
B2	$V_{O(REG0)}$	Read/Write	Battery Regulation Voltage: 20 mV step (default 0)
B1	OTG_PL	Read/Write	1-Active at High level, 0-Active at Low level (default 1), for bq24153/8 only; NA—for bq24156.
B0 (LSB)	OTG_EN	Read/Write	1-Enable OTG Pin, 0-Disable OTG pin (default 0), for bq24153/8 only; NA—for bq24156.

- Charge voltage range is 3.5 V to 4.44 V with the offset of 3.5 V and steps of 20 mV (default 3.54 V), using bits B2-B7.

Table 6. Vender/Part/Revision Register (Read only)
Memory Location: 03, Reset State: 0101 000x

BIT	NAME	READ/WRITE	FUNCTION
B7 (MSB)	Vender2	Read Only	Vender Code: bit 2 (default 0)
B6	Vender1	Read Only	Vender Code: bit 1 (default 1)
B5	Vender0	Read Only	Vender Code: bit 0 (default 0)
B4	PN1	Read Only	For I2C Address 6BH: 00--bq24151, 01--bq24150; 10--bq24153; 11--NA. For I2C Address 6AH: 00--bq24156, 01--NA, 10--bq24158, 11--NA.
B3	PN0	Read Only	
B2	Revision2	Read Only	011: Revision 1.0; 001: Revision 1.1; 100-111: Future Revisions
B1	Revision1	Read Only	
B0 (LSB)	Revision0	Read Only	

Table 7. Battery Termination/Fast Charge Current Register (Read/Write)
Memory Location: 04, Reset State: 0000 0001

BIT	NAME	READ/WRITE	FUNCTION
B7 (MSB)	Reset	Read/Write	Write: 1-Charger in reset mode, 0-No effect, Read: always get "0"
B6	$V_{I(CHRG3)}^{(1)}$	Read/Write	Charge current sense voltage: 27.2 mV step – for bq24153/8; 54.4mV step – for bq24156 (default 0)
B5	$V_{I(CHRG2)}^{(1)}$	Read/Write	Charge current sense voltage: 13.6 mV step – for bq24153/8; 27.2mV step – for bq24156 (default 0)
B4	$V_{I(CHRG1)}^{(1)}$	Read/Write	Charge current sense voltage: 6.8 mV step – for bq24153/8; 13.6mV step – for bq24156 (default 0)
B3	$V_{I(CHRG0)}^{(1)}$	Read/Write	NA – for bq24153/8; 6.8mV step – for bq24156 (default 0)
B2	$V_{I(TERM2)}^{(2)}$	Read/Write	Termination current sense voltage: 13.6 mV step (default 0)
B1	$V_{I(TERM1)}^{(2)}$	Read/Write	Termination current sense voltage: 6.8 mV step (default 0)
B0 (LSB)	$V_{I(TERM0)}^{(2)}$	Read/Write	Termination current sense voltage: 3.4 mV step (default 1)

(1) Refer to [Table 11](#)

(2) Refer to [Table 10](#)

- For bq24153/8, charge current sense voltage offset is 37.4mV and default charge current is 550mA, if 68-mΩ sensing resistor is used and LOW_CHG=0.
- For bq24156, the maximum charge current is 1.55A. If a higher value is programmed, the 1.55A or maximum safety limit charge current is selected.

Table 8. Special Charger Voltage/Enable Pin Status Register
Memory location: 05, Reset state: 001X X100

BIT	NAME	READ/WRITE	FUNCTION
B7 (MSB)	NA	Read/Write	NA
B6	NA	Read/Write	NA
B5	LOW_CHG	Read/Write	0 – Normal charge current sense voltage at 04H, 1 – Low charge current sense voltage of 22.1mV (default 1)
B4	DPM_STATUS	Read Only	0 – DPM mode is not active, 1 – DPM mode is active
B3	CD_STATUS	Read Only	0 – CD pin at LOW level, 1 – CD pin at HIGH level
B2	VSREG2	Read/Write	Special charger voltage: 320mV step (default 1)
B1	VSREG1	Read/Write	Special charger voltage: 160mV step (default 0)
B0 (LSB)	VSREG0	Read/Write	Special charger voltage: 80mV step (default 0)

- Special charger voltage offset is 4.2V and default special charger voltage is 4.52V.
- Default charge current will be 325mA, if 68-mΩ sensing resistor is used, since default LOW_CHG=1.

**Table 9. Safety Limit Register (READ/WRITE, Write only once after reset!)
Memory location: 06, Reset state: 01000000**

BIT	NAME	READ/WRITE	FUNCTION
B7 (MSB)	V _{MCHRG3} ⁽¹⁾	Read/Write	Maximum charge current sense voltage: 54.4 mV step (default 0) ⁽²⁾
B6	V _{MCHRG2} ⁽¹⁾	Read/Write	Maximum charge current sense voltage: 27.2 mV step (default 1)
B5	V _{MCHRG1} ⁽¹⁾	Read/Write	Maximum charge current sense voltage: 13.6 mV step (default 0)
B4	V _{MCHRG0} ⁽¹⁾	Read/Write	Maximum charge current sense voltage: 6.8 mV step (default 0)
B3	V _{MREG3}	Read/Write	Maximum battery regulation voltage: 160 mV step (default 0)
B2	V _{MREG2}	Read/Write	Maximum battery regulation voltage: 80 mV step (default 0)
B1	V _{MREG1}	Read/Write	Maximum battery regulation voltage: 40 mV step (default 0)
B0 (LSB)	V _{MREG0}	Read/Write	Maximum battery regulation voltage: 20 mV step (default 0)

(1) Refer to [Table 11](#)

- Maximum charge current sense voltage offset is 37.4 mV (550mA), default at 64.6mV (950mA) and the maximum charge current option is 1.55A (105.4mV), if 68-mΩ sensing resistor is used.
- Maximum battery regulation voltage offset is 4.2V (default at 4.2V) and maximum battery regulation voltage option is 4.44V.
- Memory location 06H resets only when V_{CSOUT} drops below V_{SHORT} threshold (typ. 2.05V) or SLRST (pin D4, for bq24156 only) goes to logic '0'. After reset, the maximum values for battery regulation voltage and charge current can be programmed until any writing to other register locks the safety limits. Programmed values exclude higher values from memory locations 02 (battery regulation voltage), and from memory location 04 (Fast charge current).
- If host accesses (write command) to some other register before Safety limit register, the safety default values hold!

APPLICATION SECTION

Charge Current Sensing Resistor Selection Guidelines

Both the termination current range and charge current range depend on the sensing resistor (R_{SNS}). The termination current step (I_{O(TERM_STEP)}) can be calculated using [Equation 1](#):

$$I_{O(TERM_STEP)} = \frac{V_{I(TERM0)}}{R_{(SNS)}} \quad (1)$$

[Table 10](#) shows the termination current settings for two sensing resistors.

Table 10. Termination Current Settings for 68-mΩ and 100-mΩ Sense Resistors

BIT	V _{I(TERM)} (mV)	I _(TERM) (mA) R _(SNS) = 68mΩ	I _(TERM) (mA) R _(SNS) = 100mΩ
V _{I(TERM2)}	13.6	200	136
V _{I(TERM1)}	6.8	100	68
V _{I(TERM0)}	3.4	50	34
Offset	3.4	50	34

The charge current step (I_{O(CHARGE_STEP)}) is calculated using [Equation 2](#):

$$I_{O(CHARGE_STEP)} = \frac{V_{I(CHRG0)}}{R_{(SNS)}} \quad (2)$$

[Table 11](#) shows the charge current settings for two sensing resistors.

Table 11. Charge Current Settings for 68-mΩ and 100-mΩ Sense Resistors

BIT	V _{I(REG)} (mV)	I _{O(CHARGE)} (mA) R _(SNS) = 68mΩ	I _{O(CHARGE)} (mA) R _(SNS) = 100mΩ
V _{I(CHRG3)}	54.4	800	544
V _{I(CHRG2)}	27.2	400	272
V _{I(CHRG1)}	13.6	200	136
V _{I(CHRG0)}	6.8	100	68
Offset	37.4	550	374

Output Inductor and Capacitance Selection Guidelines

The IC provides internal loop compensation. With this scheme, best stability occurs when LC resonant frequency, f_o , is approximately 40 kHz (20 kHz to 80 kHz). Equation 3 can be used to calculate the value of the output inductor, L_{OUT}, and output capacitor, C_{OUT}.

$$f_o = \frac{1}{2\pi \times \sqrt{L_{OUT} \times C_{OUT}}} \quad (3)$$

To reduce the output voltage ripple, a ceramic capacitor with the capacitance between 4.7 μF and 47 μF is recommended for C_{OUT}, see the application section for components selection.

POWER TOPOLOGIES

System Load After Sensing Resistor

One of the simpler high-efficiency topologies connects the system load directly across the battery pack, as shown in Figure 35. The input voltage has been converted to a usable system voltage with good efficiency from the input. When the input power is on, it supplies the system load and charges the battery pack at the same time. When the input power is off, the battery pack powers the system directly.

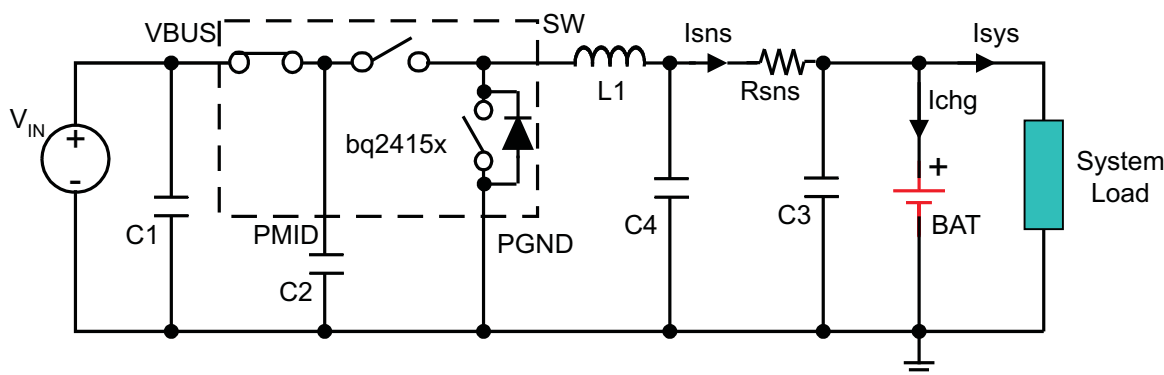

Figure 35. System Load After Sensing Resistor

The advantages:

1. When the AC adapter is disconnected, the battery pack powers the system load with minimum power dissipations. Consequently, the time that the system runs on the battery pack can be maximized.
2. It saves the external path selection components and offers a low-cost solution.
3. Dynamic power management (DPM) can be achieved. The total of the charge current and the system current can be limited to a desired value by setting charge current value. When the system current increases, the charge current drops by the same amount. As a result, no potential over-current or over-heating issues are caused by excessive system load demand.
4. The total of the input current can be limited to a desired value by setting input current limit value. So USB specifications can be met easily.
5. The supply voltage variation range for the system can be minimized.

6. The input current soft-start can be achieved by the generic soft-start feature of the IC.

Design considerations and potential issues:

1. If the system always demands a high current (but lower than the regulation current), the charging never terminates. Thus, the battery is always charged, and the lifetime may be reduced.
2. Because the total current regulation threshold is fixed and the system always demands some current, the battery may not be charged with a full-charge rate and thus may lead to a longer charge time.
3. If the system load current is large after the charger has been terminated, the IR drop across the battery impedance may cause the battery voltage to drop below the refresh threshold and start a new charge cycle. The charger would then terminate due to low charge current. Therefore, the charger would cycle between charging and terminating. If the load is smaller, the battery has to discharge down to the refresh threshold, resulting in a much slower cycling.
4. In a charger system, the charge current is typically limited to about 30mA, if the sensed battery voltage is below 2V short circuit protection threshold. This results in low power availability at the system bus. If an external supply is connected and the battery is deeply discharged, below the short circuit protection threshold, the charge current is clamped to the short circuit current limit. This then is the current available to the system during the power-up phase. Most systems cannot function with such limited supply current, and the battery supplements the additional power required by the system. Note that the battery pack is already at the depleted condition, and it discharges further until the battery protector opens, resulting in a system shutdown.
5. If the battery is below the short circuit threshold and the system requires a bias current budget lower than the short circuit current limit, the end-equipment will be operational, but the charging process can be affected depending on the current left to charge the battery pack. Under extreme conditions, the system current is close to the short circuit current levels and the battery may not reach the fast-charge region in a timely manner. As a result, the safety timers flag the battery pack as defective, terminating the charging process. Because the safety timer cannot be disabled, the inserted battery pack must not be depleted to make the application possible.
6. For instance, if the battery pack voltage is too low, highly depleted, totally dead or even shorted, the system voltage is clamped by the battery and it cannot operate even if the input power is on.

System Load Before Sensing Resistor

The second circuit is very similar to first one; the difference is that the system load is connected before the sense resistor, as shown in [Figure 36](#).

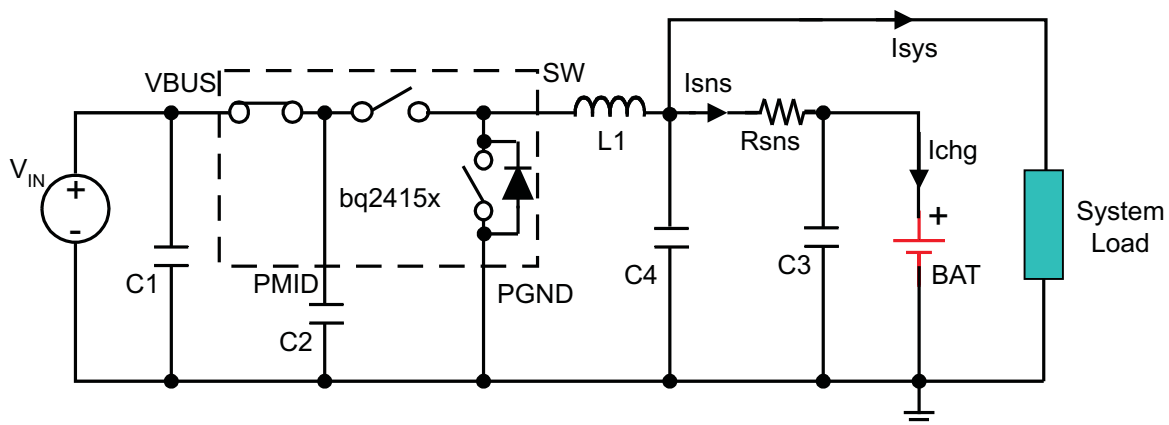

Figure 36. System Load Before Sensing Resistor

The advantages of system load before sensing resistor to system load after sensing resistor:

1. The charger controller is based only on the current goes through the current-sense resistor. So, the constant current fast charge and termination functions work well, and are not affected by the system load. This is the major advantage of it.
2. A depleted battery pack can be connected to the charger without the risk of the safety timer expiration caused by high system load.

- The charger can disable termination and keep the converter running to keep battery fully charged, or let the switcher terminate when the battery is full and then run off of the battery via the sense resistor.

Design considerations and potential issues:

- The total current is limited by the IC input current limit, or peak current protection, but not the charge current setting. The charge current does not drop when the system current load increases until the input current limit is reached. This solution is not applicable if the system requires a high current.
- Efficiency declines when discharging through the sense resistor to the system.
- No thermal regulation. Therefore, system design should ensure the maximum junction temperature of the IC is below 125°C during normal operation.

DESIGN EXAMPLE FOR TYPICAL APPLICATION CIRCUIT

Systems Design Specifications:

- $V_{BUS} = 5\text{ V}$
 - $V_{(BAT)} = 4.2\text{ V}$ (1-Cell)
 - $I_{(charge)} = 1.25\text{ A}$
 - Inductor ripple current = 30% of fast charge current
- Determine the inductor value (L_{OUT}) for the specified charge current ripple:

$$L_{OUT} = \frac{V_{BAT} \times (V_{BUS} - V_{BAT})}{V_{BUS} \times f \times \Delta I_L}$$

, the worst case is when battery voltage is as close as to half of the input voltage.

$$L_{OUT} = \frac{2.5 \times (5 - 2.5)}{5 \times (3 \times 10^6) \times 1.25 \times 0.3} \quad (4)$$

$$L_{OUT} = 1.11\ \mu\text{H}$$

Select the output inductor to standard 1 μH . Calculate the total ripple current with using the 1- μH inductor:

$$\Delta I_L = \frac{V_{BAT} \times (V_{BUS} - V_{BAT})}{V_{BUS} \times f \times L_{OUT}} \quad (5)$$

$$\Delta I_L = \frac{2.5 \times (5 - 2.5)}{5 \times (3 \times 10^6) \times (1 \times 10^{-6})} \quad (6)$$

$$\Delta I_L = 0.42\text{ A}$$

Calculate the maximum output current:

$$I_{LPK} = I_{OUT} + \frac{\Delta I_L}{2} \quad (7)$$

$$I_{LPK} = 1.25 + \frac{0.42}{2} \quad (8)$$

$$I_{LPK} = 1.46\text{ A}$$

Select 2.5mm by 2.0mm 1- μH 1.5-A surface mount multi-layer inductor. The suggested inductor part numbers are shown as following.

Table 12. Inductor Part Numbers

PART NUMBER	INDUCTANCE	SIZE	MANUFACTURER
LQM2HPN1R0MJ0	1 μ H	2.5 x 2.0 mm	Murata
MIPS2520D1R0	1 μ H	2.5 x 2.0 mm	FDK
MDT2520-CN1R0M	1 μ H	2.5 x 2.0 mm	TOKO
CP1008	1 μ H	2.5 x 2.0 mm	Inter-Technical

2. Determine the output capacitor value (C_{OUT}) using 40 kHz as the resonant frequency:

$$f_0 = \frac{1}{2\pi \times \sqrt{L_{OUT} \times C_{OUT}}} \quad (9)$$

$$C_{OUT} = \frac{1}{4\pi^2 \times f_0^2 \times L_{OUT}} \quad (10)$$

$$C_{OUT} = \frac{1}{4\pi^2 \times (40 \times 10^3)^2 \times (1 \times 10^{-6})} \quad (11)$$

$$C_{OUT} = 15.8 \mu\text{F}$$

Select two 0603 X5R 6.3V 10- μ F ceramic capacitors in parallel i.e., Murata GRM188R60J106M.

3. Determine the sense resistor using the following equation:

$$R_{(SNS)} = \frac{V_{(RSNS)}}{I_{(CHARGE)}} \quad (12)$$

The maximum sense voltage across sense resistor is 85 mV. In order to get a better current regulation accuracy, $V_{(RSNS)}$ should equal 85mV, and calculate the value for the sense resistor.

$$R_{(SNS)} = \frac{85\text{mV}}{1.25\text{A}} \quad (13)$$

$$R_{(SNS)} = 68 \text{ m}\Omega$$

This is a standard value. If it is not a standard value, then choose the next close value and calculate the real charge current. Calculate the power dissipation on the sense resistor:

$$P_{(RSNS)} = I_{(CHARGE)}^2 \times R_{(SNS)}$$

$$P_{(RSNS)} = 1.25^2 \times 0.068$$

$$P_{(RSNS)} = 0.106 \text{ W}$$

Select 0402 0.125-W 68-m Ω 2% sense resistor, i.e. Panasonic ERJ2BWGR068.

4. Measured efficiency and total power loss with different inductors are shown in [Figure 37](#). SW node and inductor current waveform are shown in [Figure 38](#).

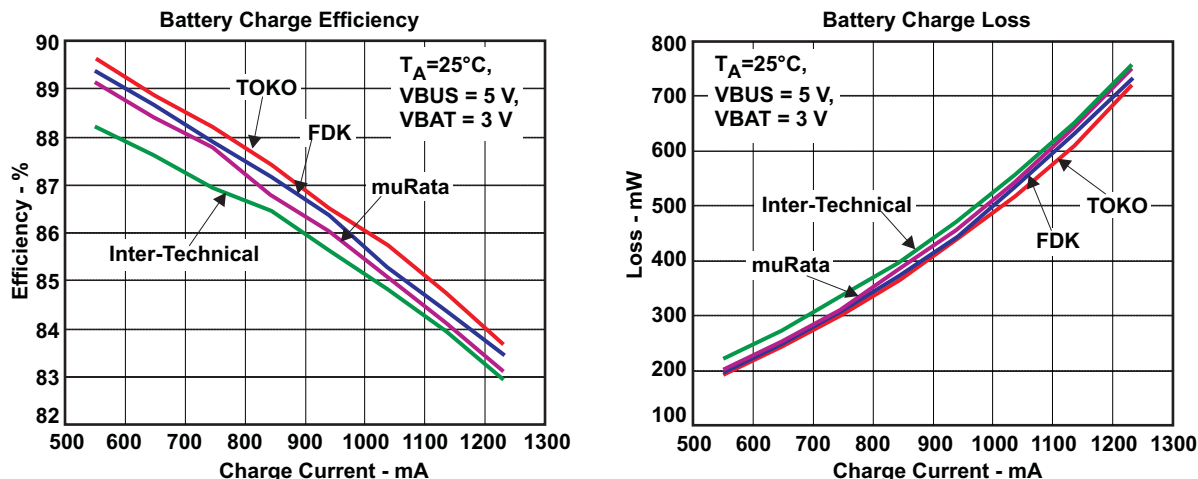

Figure 37. Measured Efficiency and Power Loss

PCB LAYOUT CONSIDERATION

It is important to pay special attention to the PCB layout. The following provides some guidelines:

- To obtain optimal performance, the power input capacitors, connected from input to PGND, should be placed as close as possible to the bqTINYSWITCHER. The output inductor should be placed close to the IC and the output capacitor connected between the inductor and PGND of the IC. The intent is to minimize the current path loop area from the SW pin through the LC filter and back to the PGND pin. To prevent high frequency oscillation problems, proper layout to minimize high frequency current path loop is critical. (See Figure 38.) The sense resistor should be adjacent to the junction of the inductor and output capacitor. Route the sense leads connected across the RSNS back to the IC, close to each other (minimize loop area) or on top of each other on adjacent layers (do not route the sense leads through a high-current path). (See Figure 39.)
- Place all decoupling capacitor close to their respective IC pin and as close as to PGND (do not place components such that routing interrupts power stage currents). All small control signals should be routed away from the high current paths.
- The PCB should have a ground plane (return) connected directly to the return of all components through vias (two vias per capacitor for power-stage capacitors, two vias for the IC PGND, one via per capacitor for small-signal components). A star ground design approach is typically used to keep circuit block currents isolated (high-power/low-power small-signal) which reduces noise-coupling and ground-bounce issues. A single ground plane for this design gives good results. With this small layout and a single ground plane, there is no ground-bounce issue, and having the components segregated minimizes coupling between signals.
- The high-current charge paths into VBUS, PMID and from the SW pins must be sized appropriately for the maximum charge current in order to avoid voltage drops in these traces. The PGND pins should be connected to the ground plane to return current through the internal low-side FET.
- Place 4.7μF input capacitor as close to PMID pin and PGND pin as possible to make high frequency current loop area as small as possible. Place 1μF input capacitor as close to VBUS pin and PGND pin as possible to make high frequency current loop area as small as possible (see Figure 40).

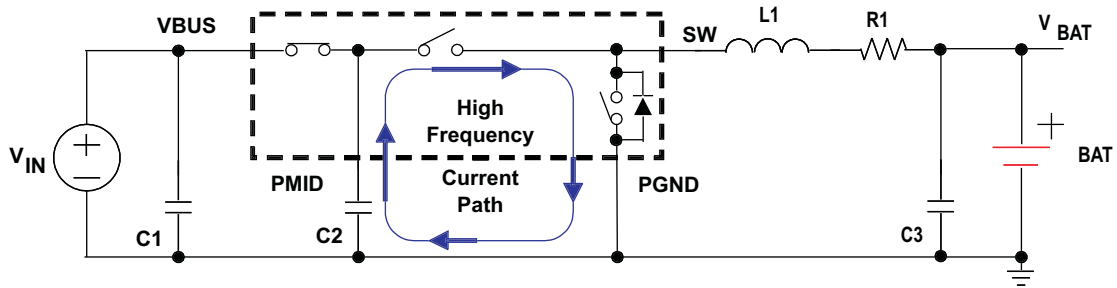

Figure 38. High Frequency Current Path

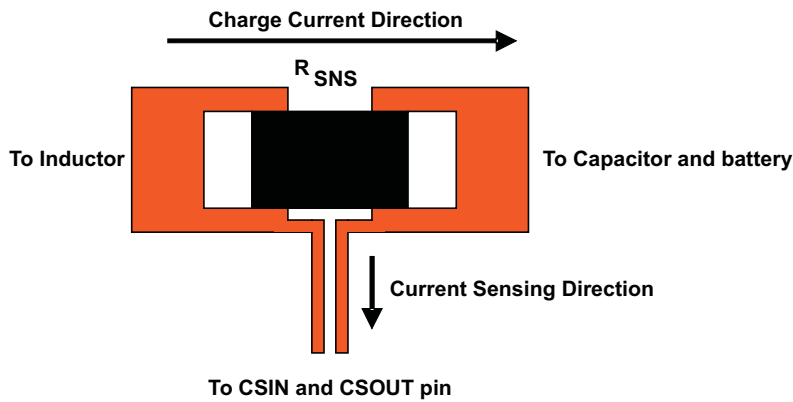

Figure 39. Sensing Resistor PCB Layout

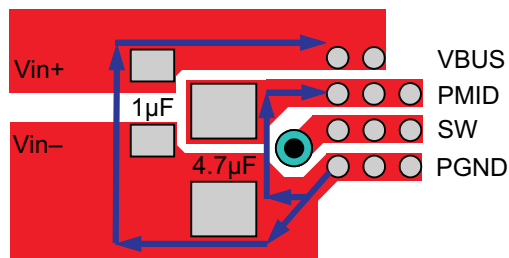
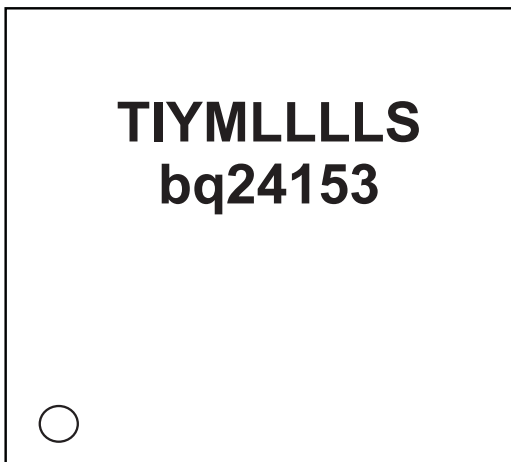

Figure 40. Input Capacitor Position and PCB Layout Example

PACKAGE SUMMARY

CHIP SCALE PACKAGE
(Top Side Symbol For bq24153)



CHIP SCALE PACKAGE
(Top Side Symbol For bq24156)

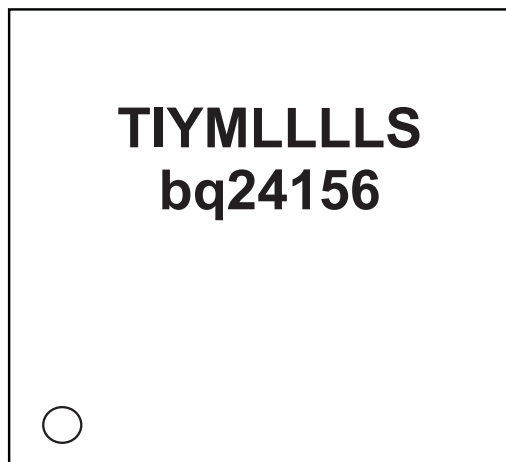

0-Pin A1 Marker, TI-TI Letters, YM- Year Month Date Code, LLLL-Lot Trace Code, S-Assembly Site Code

CHIP SCALE PACKAGE
(Top Side Symbol For bq24158)



WCSP PACKAGE
(Top View)

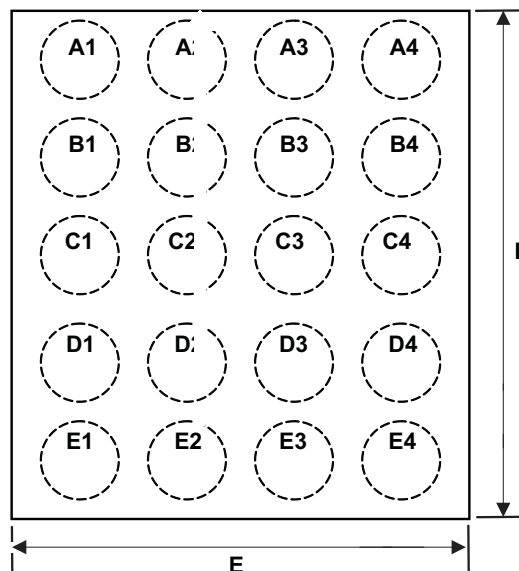

CHIP SCALE PACKAGING DIMENSIONS

The bq24153/6/8 devices are available in a 20-bump chip scale package (YFF, NanoFree™). Package dimensions are:

- D = 2.14 ± 0.03 mm
- E = 2.0 ± 0.03 mm

PACKAGING INFORMATION

Orderable Device	Status (1)	Package Type	Package Drawing	Pins	Package Qty	Eco Plan (2)	Lead finish/ Ball material (6)	MSL Peak Temp (3)	Op Temp (°C)	Device Marking (4/5)	Samples
BQ24153YFFR	ACTIVE	DSBGA	YFF	20	3000	TBD	Call TI	Call TI	-40 to 85		Samples

(1) The marketing status values are defined as follows:

ACTIVE: Product device recommended for new designs.

LIFEBUY: TI has announced that the device will be discontinued, and a lifetime-buy period is in effect.

NRND: Not recommended for new designs. Device is in production to support existing customers, but TI does not recommend using this part in a new design.

PREVIEW: Device has been announced but is not in production. Samples may or may not be available.

OBSELETE: TI has discontinued the production of the device.

(2) **RoHS:** TI defines "RoHS" to mean semiconductor products that are compliant with the current EU RoHS requirements for all 10 RoHS substances, including the requirement that RoHS substance do not exceed 0.1% by weight in homogeneous materials. Where designed to be soldered at high temperatures, "RoHS" products are suitable for use in specified lead-free processes. TI may reference these types of products as "Pb-Free".

RoHS Exempt: TI defines "RoHS Exempt" to mean products that contain lead but are compliant with EU RoHS pursuant to a specific EU RoHS exemption.

Green: TI defines "Green" to mean the content of Chlorine (Cl) and Bromine (Br) based flame retardants meet JS709B low halogen requirements of <=1000ppm threshold. Antimony trioxide based flame retardants must also meet the <=1000ppm threshold requirement.

(3) MSL, Peak Temp. - The Moisture Sensitivity Level rating according to the JEDEC industry standard classifications, and peak solder temperature.

(4) There may be additional marking, which relates to the logo, the lot trace code information, or the environmental category on the device.

(5) Multiple Device Markings will be inside parentheses. Only one Device Marking contained in parentheses and separated by a "~" will appear on a device. If a line is indented then it is a continuation of the previous line and the two combined represent the entire Device Marking for that device.

(6) Lead finish/Ball material - Orderable Devices may have multiple material finish options. Finish options are separated by a vertical ruled line. Lead finish/Ball material values may wrap to two lines if the finish value exceeds the maximum column width.

Important Information and Disclaimer:The information provided on this page represents TI's knowledge and belief as of the date that it is provided. TI bases its knowledge and belief on information provided by third parties, and makes no representation or warranty as to the accuracy of such information. Efforts are underway to better integrate information from third parties. TI has taken and continues to take reasonable steps to provide representative and accurate information but may not have conducted destructive testing or chemical analysis on incoming materials and chemicals. TI and TI suppliers consider certain information to be proprietary, and thus CAS numbers and other limited information may not be available for release.

In no event shall TI's liability arising out of such information exceed the total purchase price of the TI part(s) at issue in this document sold by TI to Customer on an annual basis.

YFF (R-XBGA-N20)

DIE-SIZE BALL GRID ARRAY

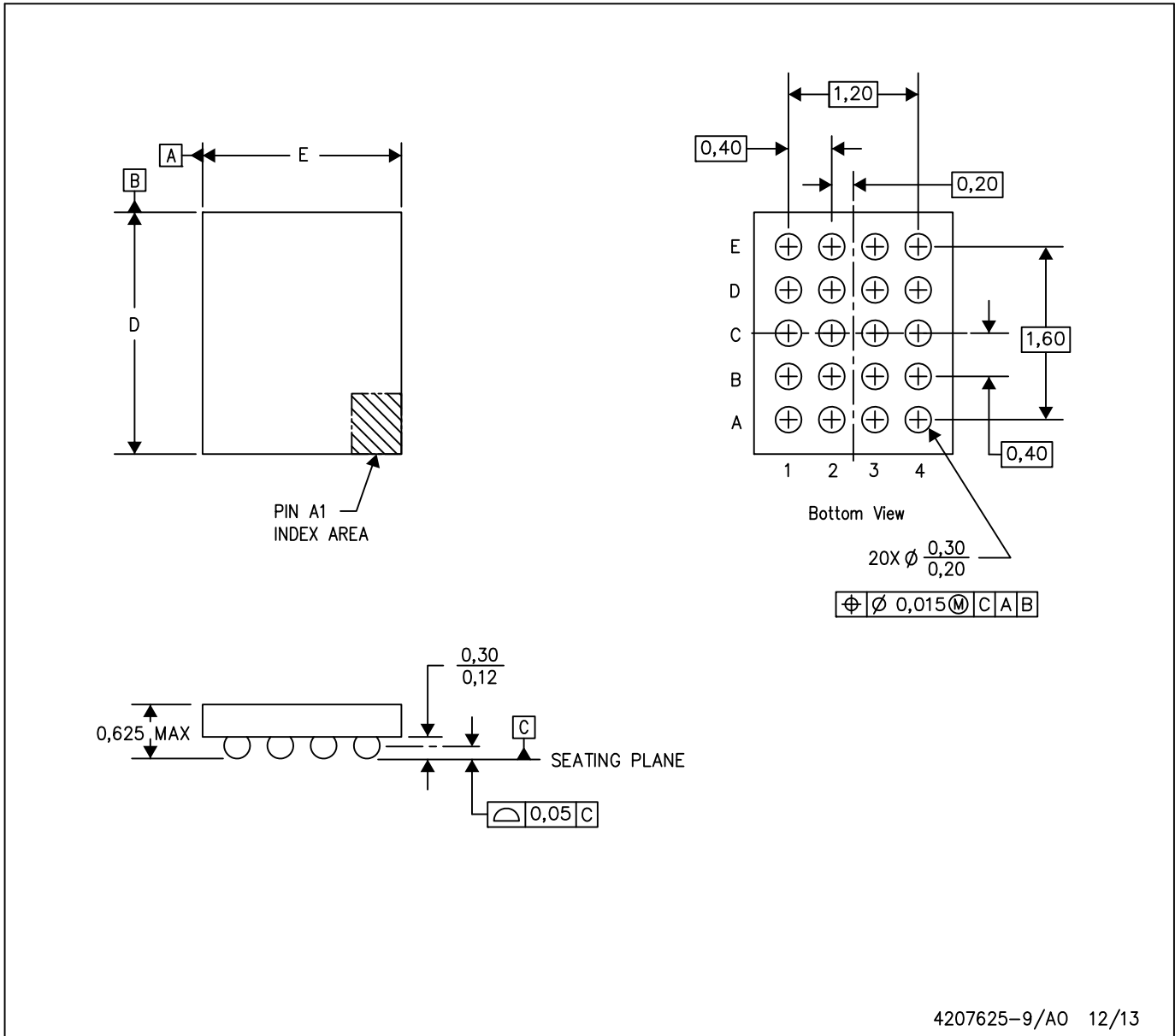

- NOTES: A. All linear dimensions are in millimeters. Dimensioning and tolerancing per ASME Y14.5M-1994.
 B. This drawing is subject to change without notice.
 C. NanoFree™ package configuration.

NanoFree is a trademark of Texas Instruments.

IMPORTANT NOTICE AND DISCLAIMER

TI PROVIDES TECHNICAL AND RELIABILITY DATA (INCLUDING DATA SHEETS), DESIGN RESOURCES (INCLUDING REFERENCE DESIGNS), APPLICATION OR OTHER DESIGN ADVICE, WEB TOOLS, SAFETY INFORMATION, AND OTHER RESOURCES "AS IS" AND WITH ALL FAULTS, AND DISCLAIMS ALL WARRANTIES, EXPRESS AND IMPLIED, INCLUDING WITHOUT LIMITATION ANY IMPLIED WARRANTIES OF MERCHANTABILITY, FITNESS FOR A PARTICULAR PURPOSE OR NON-INFRINGEMENT OF THIRD PARTY INTELLECTUAL PROPERTY RIGHTS.

These resources are intended for skilled developers designing with TI products. You are solely responsible for (1) selecting the appropriate TI products for your application, (2) designing, validating and testing your application, and (3) ensuring your application meets applicable standards, and any other safety, security, regulatory or other requirements.

These resources are subject to change without notice. TI grants you permission to use these resources only for development of an application that uses the TI products described in the resource. Other reproduction and display of these resources is prohibited. No license is granted to any other TI intellectual property right or to any third party intellectual property right. TI disclaims responsibility for, and you will fully indemnify TI and its representatives against, any claims, damages, costs, losses, and liabilities arising out of your use of these resources.

TI's products are provided subject to [TI's Terms of Sale](#) or other applicable terms available either on [ti.com](https://www.ti.com) or provided in conjunction with such TI products. TI's provision of these resources does not expand or otherwise alter TI's applicable warranties or warranty disclaimers for TI products.

TI objects to and rejects any additional or different terms you may have proposed.

Mailing Address: Texas Instruments, Post Office Box 655303, Dallas, Texas 75265
Copyright © 2024, Texas Instruments Incorporated

Looking for pricing, stock, or lifecycle information?

Click below to explore more details on WIN SOURCE:

 [View BQ24153YFFT](#) on WIN SOURCE

 [Texas Instruments](#) Information

Optimize Your Supply Chain with WIN SOURCE Solutions

-  Global Sourcing Solution
-  Obsolete Management
-  Cost Control Management
-  Shortage Management
-  Alternative Solution
-  Excess Inventory Management