



**THE DATASHEET OF
BH1790GLC-E2**



Sensor for Heart Rate Monitor ICs

Optical Sensor for Heart Rate Monitor IC

BH1790GLC

General Description

BH1790GLC is optical sensor for heart rate monitor IC in which LED driver and green light detection photo-diode are incorporated. This device drives LED and provides the intensity of light reflected from body. LED brightness can be adjusted by LED driver current and light emitting period. The photodiode having the high sensitivity for green light, excellent wavelength selectivity and excellent Ircut characteristics achieves accurate pulse wave detection.

Key Specifications

- VCC1 Voltage Range: 2.5V to 3.6V
- VCC2 Voltage Range: 1.7V to 3.6V
- Current Consumption: 200 μ A(Typ)
- Standby Mode Current: 0.8 μ A(Typ)
- Operating Temperature Range: -20°C to +85°C

Features

- Green filter with excellent wavelength selectivity.
- Built-in Ircut Filter.
- LED driver with current selection.
- Correspond to 1.8V I²C Interface.

Applications

- Wearable device, smart phone, Tablet PC.

Package

WLGA010V28

W(Typ) x D(Typ) x H(Max)

2.80mm x 2.80mm x 1.00mm

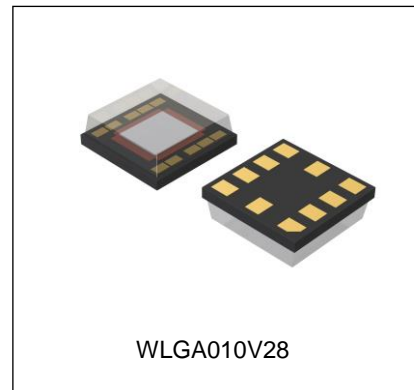

Typical Application Circuit

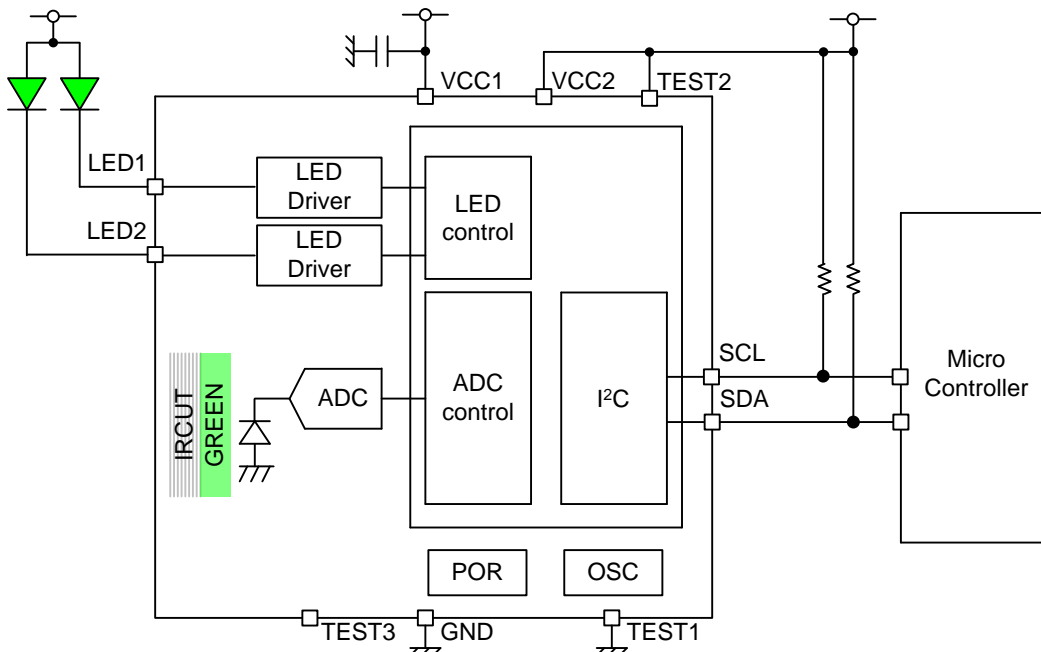

○Product structure : Silicon monolithic integrated circuit.
 ○This product does not include laser transmitter.
 ○This product includes Photo detector, (Photo Diode) inside of it.

○This product has no designed protection against radioactive rays.
 ○This product does not include optical load.

Contents

General Description	1
Features.....	1
Applications	1
Key Specifications.....	1
Package.....	1
Typical Application Circuit	1
Contents	2
Pin Configuration	3
Pin Description.....	3
Block Diagram	4
Description of Blocks	4
Absolute Maximum Ratings	5
Thermal Resistance	5
Recommended Operating Conditions.....	6
Electrical Characteristics.....	6
I ² C Bus Timing Characteristics	7
Typical Performance Curves.....	8
Figure 1. Sensitivity Ratio vs Wavelength	8
Figure 2. Sensor out vs Temperature	8
Figure 3. Ratio vs Angle	8
Figure 4. Ratio vs Angle	8
Measurement Sequence.....	8
Register Map	11
Power Supply Sequence.....	14
I ² C Bus Communication.....	15
Application Example	16
I/O equivalent circuit	17
Operational Notes.....	18
Ordering information	20
Marking Diagram	20
Optical design for the device.....	20
Physical Dimension, Tape and Reel Information.....	21
Revision History.....	22

Pin Configuration

(TOP VIEW)

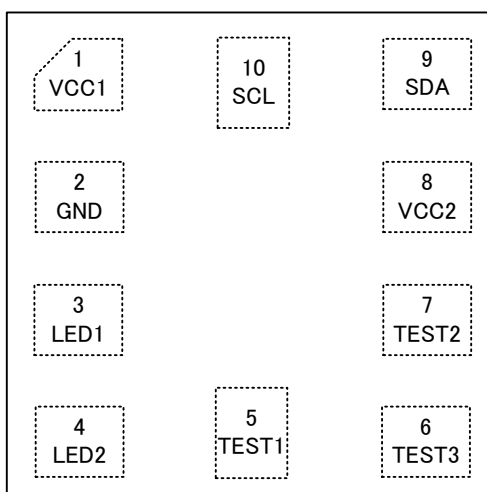

Pin Description

Pin No.	Pin Name	Function
1	VCC1	Power supply terminal
2	GND	GND terminal
3	LED1	LED1 driver output
4	LED2	LED2 driver output
5	TEST1	TEST1 terminal ^(Note 1)
6	TEST3	TEST3 terminal ^(Note 4)
7	TEST2	TEST2 terminal ^(Note 3)
8	VCC2	IO Power supply terminal ^(Note 2)
9	SDA	I ² C bus interface SDA terminal
10	SCL	I ² C bus interface SCL terminal

(Note 1) connect to GND.

(Note 2) connect to I²C Pull up power supply.

(Note 3) connect to VCC2.

(Note 4) no connect.

Block Diagram

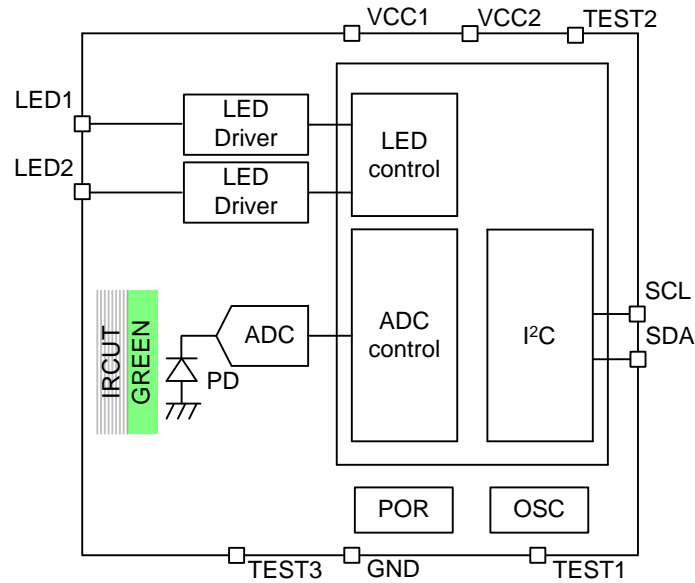

Description of Blocks

- IRCUT
This filter passes visible light and blocks infrared light.
- GREEN
Green color pass filter
- PD
Photodiodes (PD) convert light into current.
- LED Driver
LED driver circuit
- ADC
AD converter
- OSC
Internal oscillator generates clock for internal logic.
- POR
Power on reset
- I²C
I²C bus interface
- ADC control
AD converter control block
- LED control
LED driver control block

Absolute Maximum Ratings (Ta = 25°C)

Parameter	Symbol	Rating	Unit
Supply Voltage	V _{CCMAX}	4.5	V
LOGIC terminal Voltage	V _{IN}	-0.3 to +4.5	V
LED terminal Voltage	V _{LED}	7	V
Operating Temperature	T _{OPR}	-20 to +85	°C
Storage Temperature	T _{STG}	-40 to +100	°C

Caution: Operating the IC over the absolute maximum ratings may damage the IC. The damage can either be a short circuit between pins or an open circuit between pins and the internal circuitry. Therefore, it is important to consider circuit protection measures, such as adding a fuse, in case the IC is operated over the absolute maximum ratings.

Thermal Resistance

Parameter	Symbol	Thermal Resistance (Typ)		Unit
		1s	2s2p	
WLGA010V28				
Junction to Ambient	θ_{JA}	398.4	218.3	°C/W

Layer Number of Measurement Board	Material	Board Size
Single	FR-4	70.0mm x 70.0mm x 1.6mmt

Top	
Copper Pattern	Thickness
Footprints and Traces	35 μ m

Layer Number of Measurement Board	Material	Board Size
4 Layers	FR-4	70.0mm x 70.0mm x 1.6mmt

Top		2 Internal Layers		Bottom	
Copper Pattern	Thickness	Copper Pattern	Thickness	Copper Pattern	Thickness
Footprints and Traces	35 μ m	70.0mm x 70.0mm	35 μ m	70.0mm x 70.0mm	35 μ m

Recommended Operating Conditions (Ta= -20°C to +85°C)

Parameter	Symbol	Min	Typ	Max	Unit
VCC1 Supply Voltage	V _{CC1}	2.5	3.0	3.6	V
VCC2 Supply Voltage	V _{CC2}	1.7	3.0	3.6	V
LED1, LED2 Terminal Voltage	V _{LED}	0.7	-	5.5	V

Electrical Characteristics

(Unless otherwise specified VCC1=3.0V, VCC2=3.0V, Ta=25°C, RCYCLE=32Hz Mode)

Parameter	Symbol	Min	Typ	Max	Unit	Conditions
Supply Current	I _{CC1}	-	200	400	μA	LED no emitting
Supply Current during LED current drive	I _{CC2}	-	1.6	3.2	mA	LED emitting LED_CURRENT=10mA Mode
Standby Mode Current	I _{CC3}	-	0.8	1.5	μA	No input light
Green Data Count Value	D _{GREEN}	1750	2700	3650	count	EV=10μW/cm ² (Note1)
Dark Count Value	S _{0,0}	-	0	100	count	No input light
Measurement Time	T _{INT}	-	-	28	ms	
LED Emitting Time	t _{wLED}	-	300	410	μs	
LED Output Current	I _{LED}	5	10	15	mA	LED terminal voltage = 1.0V LED_CURRENT=10mA Mode
LED Off Leakage Current	I _{OFF}	-	0	1	μA	LED terminal voltage = 5.5V
OSC Cycle	t _{OSC}	-	1.4	1.9	μs	
SCL SDA Input 'H' Voltage	V _{IH}	1.26	-	-	V	
SCL SDA Input 'L' Voltage	V _{IL}	-	-	0.54	V	
SCL SDA Input 'H/L' Current	I _{IHL}	-10	-	10	μA	
I ² C SDA Output 'L' Voltage	V _{OL}	0	-	0.4	V	IOL = +3mA

(Note 1) Green LED(λ_p=527nm) is used as optical source.

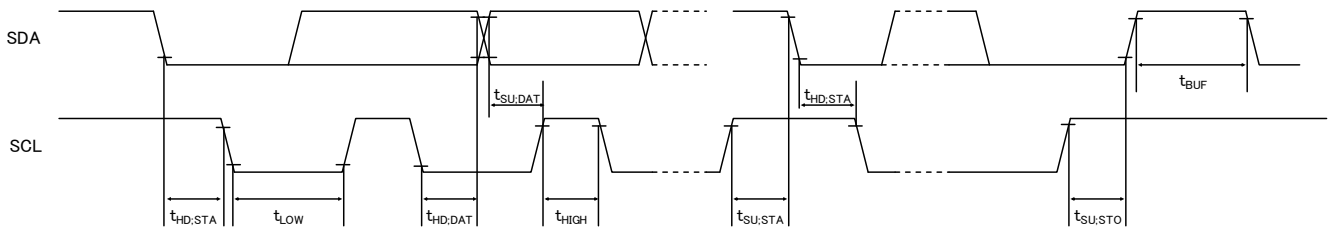
I²C Bus Timing Characteristics (Unless otherwise specified VCC1=3.0V, VCC2=3.0V, Ta=25°C)

Parameter	Symbol	Min.	Typ.	Max.	Units	Conditions
I ² C SCL Clock frequency	f_{SCL}	0	-	400	kHz	
I ² C 'L' Period of the SCL Clock	t_{LOW}	1.3	-	-	μ s	
I ² C 'H' Period of the SCL Clock	t_{HIGH}	0.6	-	-	μ s	
I ² C START Condition Setup Time	$t_{SU,STA}$	0.6	-	-	μ s	
I ² C Hold Time (Repeated) STARTCondition	$t_{HD,STA}$	0.6	-	-	μ s	
I ² C Data Setup Time	$t_{SU,DAT}$	100	-	-	ns	
I ² C Data Hold Time	$t_{HD,DAT}$	0	-	-	μ s	
I ² C Setup Time for STOP Condition	$t_{SU,STO}$	0.6	-	-	μ s	
I ² C Bus Free Time between a STOP and START Condition	t_{BUF}	1.3	-	-	μ s	

Typical Performance Curves

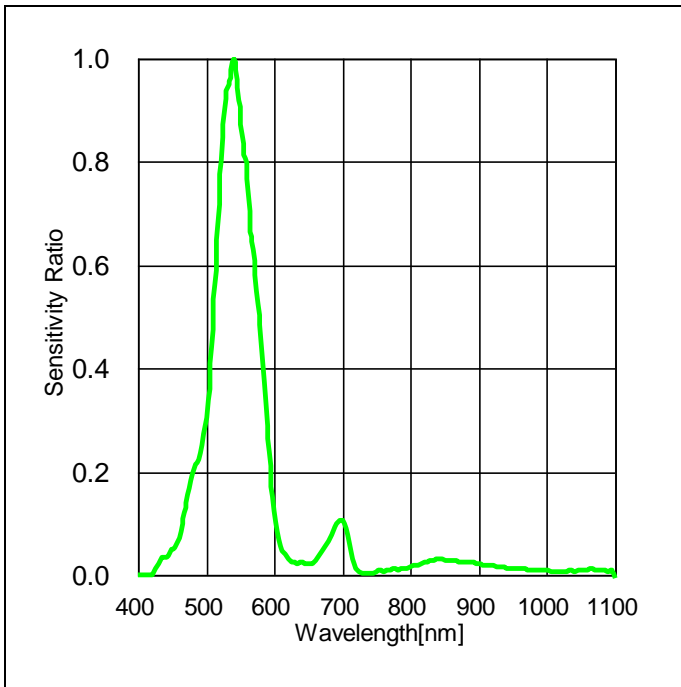

Figure 1. Sensitivity Ratio vs Wavelength
("Green Spectral Response")

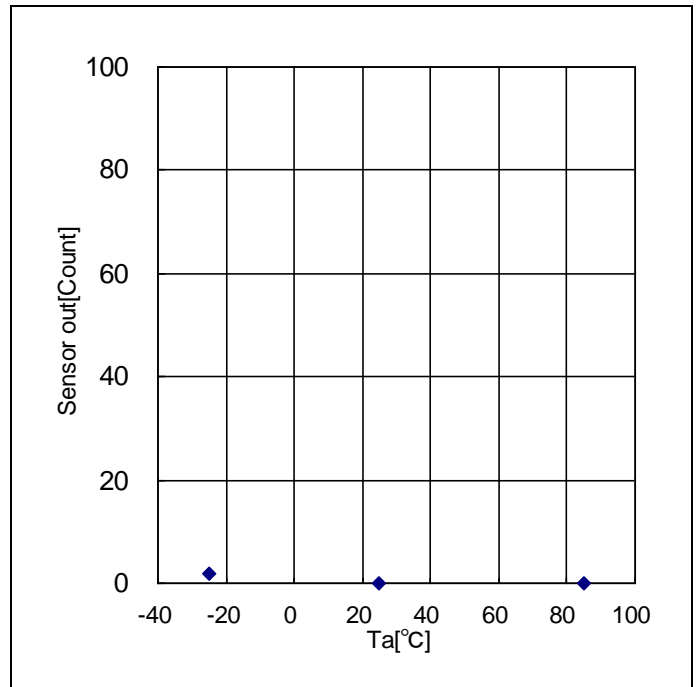

Figure 2. Sensor out vs Temperature
("Temperature Dependency of Dark (0lx) Sensor out ",
MEAS_CONTROL1(41h)=82h)

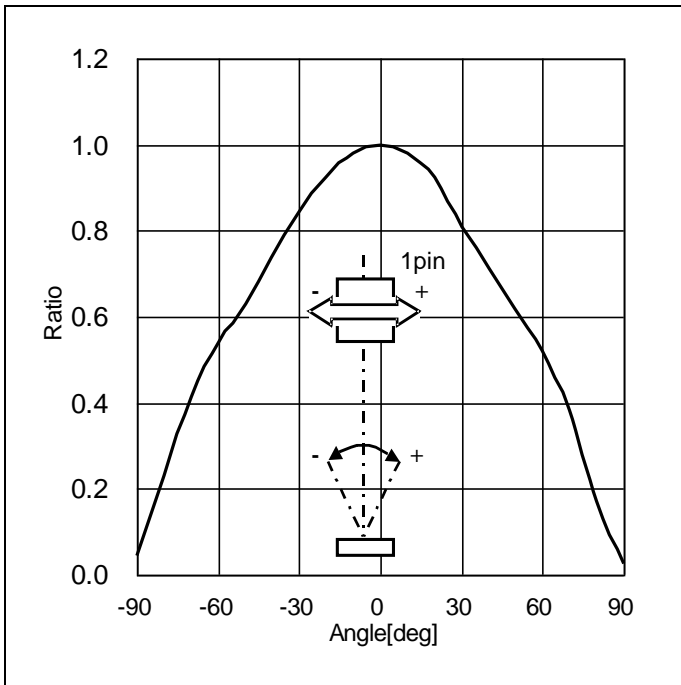

Figure 3. Ratio vs Angle
("Directional Characteristics 1")

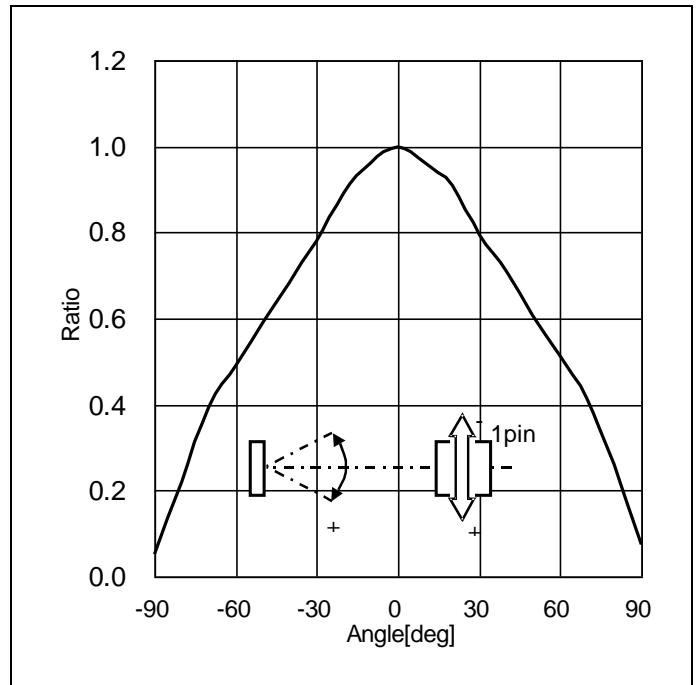
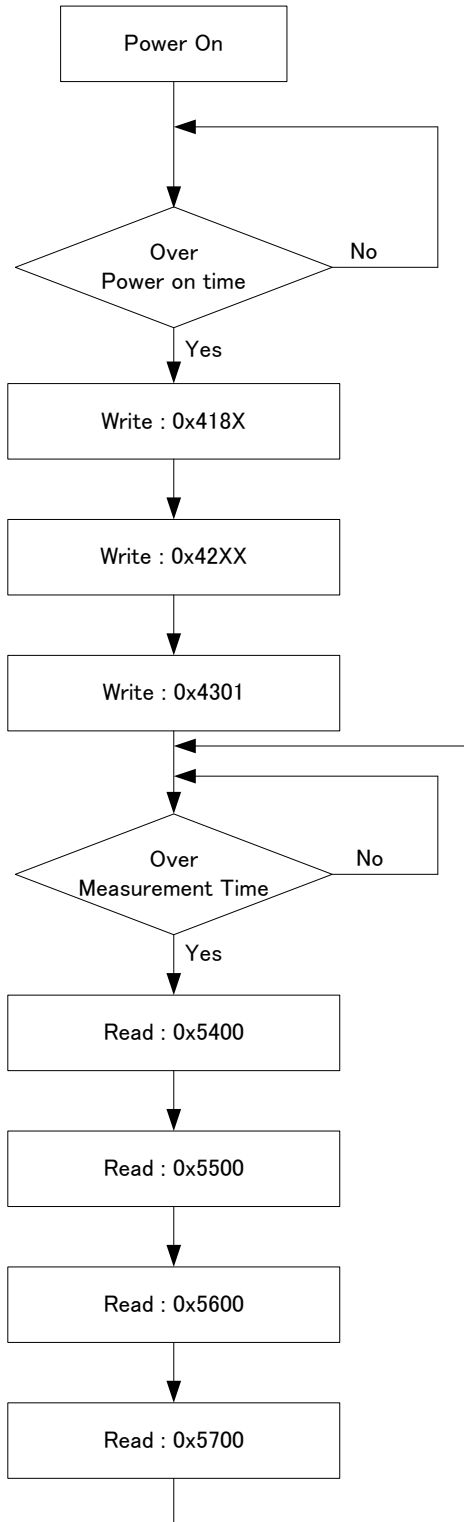

Figure 4. Ratio vs Angle
("Directional Characteristics 2")

Measurement Sequence

1. Power On
 2. Start measurement by writing the parameters of address 41h to 43h.
 3. Read data in order of address 54h to 57h after measurement complementation.
Measurement finished within measurement time^(Note 1).
Reading the data of address 57h restart measurement.
 4. After restart of measurement, repeat step3 then measurement data can be read.
 5. Write "SWRESET=1" (Address 40h), when stop measurement or change parameter.
Repeat from step 2, when start measurement again.
 6. Parameter refreshment is recommended. Write parameter of address 41h to 43h regularly after reading data.
- (Note 1) Measurement time is changed by "RCYCLE" (Address 41h).



Set parameter more than power on time t_2 ^(Note 2) after power on.
(Note 2) Refer to "Power Supply Sequence".

Set parameter in order of address 41h, 42h and 43h.

1. Wait measurement complementation.
2. Read data in order of address 54h, 55h, 56h and 57h after waiting more than measurement time T_{INT} .

[Example : Measurement Sequence] LED_LIGHT_FREQ=0, RCYCLE=0x2, Read cycle=32Hz

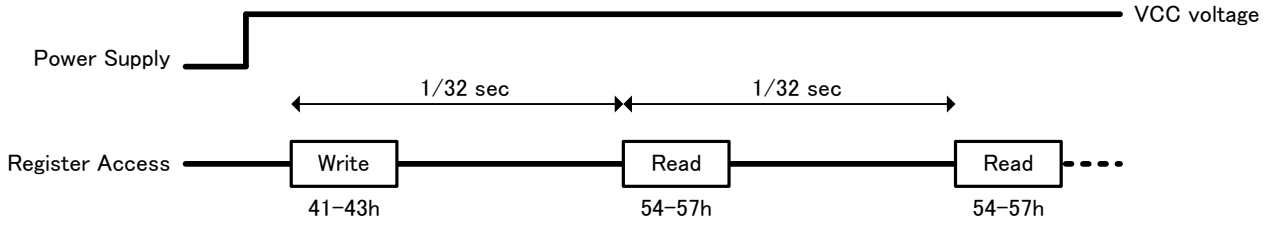

[Example : Parameter Refreshment] Changing register value is prohibited.

Write register value after read data.

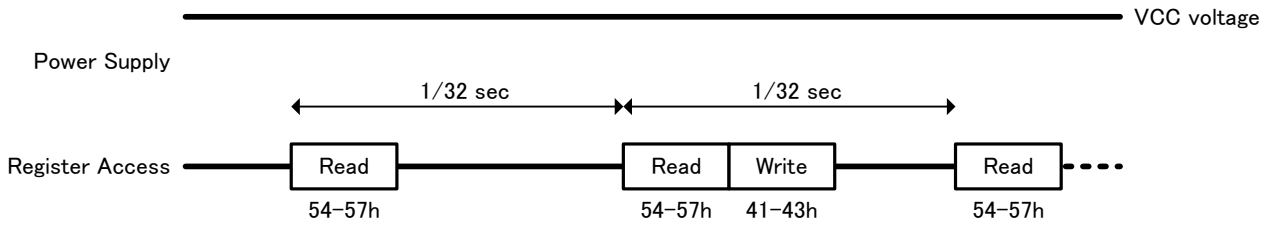

[Example : Parameter Change] Register value can be changed.

Write register value after writing register "SWRESET=1"

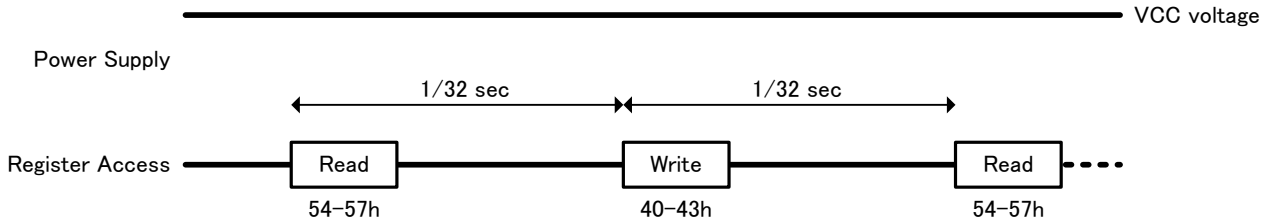

Register Map

Name	Address	R/W	Default	Function
MANUFACTURER ID	0x0F/0x92	R	0xE0	Manufacturer ID
PART ID	0x10	R	0x0D	Part ID
RESET	0x40	RW	0x00	SWRESET
MEAS_CONTROL1	0x41	RW	0x00	Measurement setting Control
MEAS_CONTROL2	0x42	RW	0x00	Measurement setting Control
MEAS_START	0x43	RW	0x00	Start Measurement
DATAOUT_LED OFF	0x54/0x55	R	0xFF	Measurement Data (LED OFF)
DATAOUT_LED ON	0x56/0x57	R	0xFF	Measurement Data (LED ON)

○ MANUFACTURER ID (0x0F/0x92h)

Register	R/W	Address	Function
MANUFACTURER ID	R	0x0F/0x92	Manufacturer ID : 0xE0

○ PART ID (0x10h)

Register	R/W	Address	Function
PART ID	R	0x10	Part ID : 0x0D

○ RESET (0x40h)

Register	R/W	Address	Function
RESET	R/W	0x40	Reset

default value 0x00

Bit	Name	Function
7	SWRESET	1 : Software reset is performed
6:0	Reserved	Write "0"

<SWRESET>

Reset process is performed when writing SWRESET=1.

"1" is not written in register "SWRESET", Read value is always "0"

○ MEAS_CONTROL1 (0x41h)

Register	R/W	Address	Function
MEAS_CONTROL1	R/W	0x41	System control setting

default value 0x00

Bit	Name	Function
7	RDY	0 : Prohibited 1 : OSC block is active
6:3	Reserved	Write "0"
2	LED_LIGHTING_FREQ	Select LED emitting frequency 0 : 128Hz Mode, 1 : 64Hz Mode
1:0	RCYCLE	Select Data reading frequency 00 : Prohibited, 01 : 64Hz Mode, 10 : 32Hz Mode, 11 : Prohibited

<RDY>

OSC block is active at "RDY=1".

OSC block is supply clock to internal block.

<LED_LIGHTING_FREQ>

Select LED emitting frequency.

<RCYCLE>

Select Measurement time corresponding to data reading frequency. Measurement time depends on OSC cycle.

64Hz Mode : $7370 \times t_{osc}$ ms32Hz Mode : $14740 \times t_{osc}$ ms

○ MEAS_CONTROL2 (0x42h)

Register	R/W	Address	Function
MEAS_CONTROL2	R/W	0x42	Measurement control setting

default value 0x00

Bit	Name	Function
7:6	LED_EN	Select LED driver mode
5	LED_ON_TIME	Select LED emitting time 0 : 0.3ms Mode, 1 : 0.6ms Mode
4	Reserved	Write "0"
3:0	LED_CURRENT	Select LED driver current

<LED_EN>

Select LED driver mode.

LED_EN[1:0]	LED1	LED2
00	(Note 1)	(Note 1)
01	Constant Light Emission	(Note 1)
10	(Note 1)	Constant Light Emission
11	Constant Light Emission	Constant Light Emission

(Note 1) Pulsed light emit after starting measurement(Write "MEAS_ST=1" or Read address 57h).

No light emit after measurement completion.

<LED_ON_TIME>

Select LED emitting time.

LED emitting time depends on by OSC cycle.

0.3ms Mode : $216 \times t_{osc} \mu s$

0.6ms Mode : $432 \times t_{osc} \mu s$

<LED_CURRENT>

Select LED lighting current.

LED_CURRENT[3:0]	Current Mode
0x0	0mA Mode
0x1 to 0x7	Prohibited
0x8	1mA Mode
0x9	2mA Mode
0xA	3mA Mode
0xB	6mA Mode
0xC	10mA Mode
0xD	20mA Mode
0xE	30mA Mode
0xF	60mA Mode

○ MEAS_START (0x43h)

Register	R/W	Address	Function
MEAS_START	R/W	0x43	Measurement start

default value 0x00

Bit	Name	Function
7:1	Reserved	Write "0"
0	MEAS_ST	Flag of start measurement 0 : Prohibited, 1 : Measurement start

<MEAS_ST>

Start measurement by writing "MEAS_ST=1" after writing "RDY=1".

Measurement doesn't restart if writing "MEAS_ST=1" after start measurement.

When stop measurement, write "SWRESET=1" without writing "MEAS_ST=0".

○ DATAOUT (0x54/0x55, 0x56/0x57h)

Register	R/W	Address	Function
DATAOUT_LED OFF data	R	0x54	lower 8bit
		0x55	upper 8bit
DATAOUT_LED ON data	R	0x56	lower 8bit
		0x57	upper 8bit

default value 0xFFFF

DATAOUT_LED OFF data : Green Data Count Value when LED no emitting

DATAOUT_LED ON data : Green Data Count Value when LED emitting

DATA value is MSB first.

Read data in order of address 0x54h to 0x57 after waiting measurement time.

Measurement is restarted by reading address 0x57.

Explanation of Software Reset Command

All registers are reset by Software reset command.

Power Supply Sequence

Supply power to VCC1 with VCC2, or after supply power to VCC2.
 This IC has POR function triggered by VCC1 voltage.
 All registers are reset when power supply to VCC1 by POR circuit.

Please note the below behavior when application design.

1. Power on time VCC1 : t1
 "t1" should be more than 0ms.
2. Power on time : t2
 "t2" should be more than 2ms. The IC becomes active state 2ms after VCC1 voltage goes beyond 2.5V.
3. Power off time : t3
 "t3" should be more than 1ms.
 VCC1 voltage should keep being less than 0.4V for more than 1ms, before supplying power to VCC1.

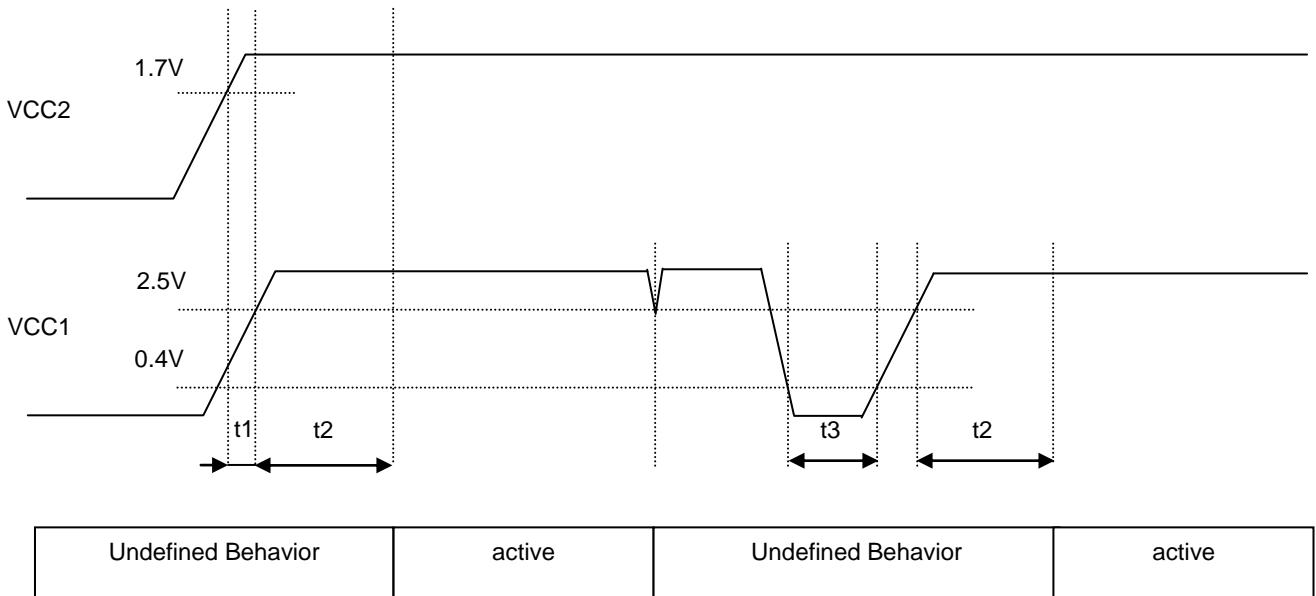

* "active state" means the state that This IC operates correctly.
 Once VCC1 goes below 2.5V, power supply sequence should follow below sequence.

I²C Bus Communication

1. Slave address "1011011"

2. Main write format

(1) Indicate register address

ST	Slave Address	W 0	ACK	Indicate register address	ACK	SP
----	---------------	--------	-----	---------------------------	-----	----

(2) Write to data register after indicating register address

ST	Slave Address	W 0	ACK	Indicate register address	ACK	
Data specified at register address field	ACK	ACK	Data specified at register address field + N	ACK	SP

This IC continues to receive data with address increments until master issues stop condition.
Write cycle is 40h - 41h - 42h - 43h ...55h - 56h - 57h ...FFh - 00h - 01h ...3Fh - 40h.....
All registers are included in write-chain.

Ex) If register address field is 41h, then this IC writes data like seeing in below.
41h - 42h - 43h 3Eh - 3Fh - 40h..... It is continued until master issues stop condition.

*There is no registers in address 00h - 0Eh, 11h - 3Fh, 44h - 53h, 58h - 91h and 93h - FFh, but it is necessary to access these registers when writing some data with address increments. It is recommended to access 40h - 43h individually.

3. Main read format

(1) Read data after indicate register address (Master issues restart condition)

ST	Slave Address	W 0	ACK	Indicate register address	ACK	
ST	Slave Address	R 1	ACK	Data specified at register address field	ACK	
Data specified at register address field + 1	ACK	ACK	Data specified at register address field + N	NACK	SP

(2) Case of read data

ST	Slave Address	R 1	ACK	Data specified at register address field	ACK	
Data specified at register address field + 1	ACK	ACK	Data specified at register address field + N	NACK	SP

This IC continue to output data from specified address field until master issues stop condition.
Read cycle is 40h - 41h - 42h - 43h ...55h - 56h - 57h ...FFh - 00h - 01h ...3Fh - 40h.....
All registers are included in read-chain.

Ex) If register address field is 54h, then this IC outputs data like seeing in below.
54h - 55h - 56hFFh - 00h - 01h...3Fh - 40h... It is continued until master issues stop condition.

*There is no registers in address 00h - 0Eh, 11h - 3Fh, 44h - 53h, 58h - 91h and 93h - FFh, but it is necessary to access these registers when reading data with address increments. It is recommended to access 41h - 43h, 54h - 57h, 0Fh - 10h and 92h individually.



*This IC operates as I²C bus slave device.

*Please refer formality I²C bus specification of NXP semiconducto

Application Example

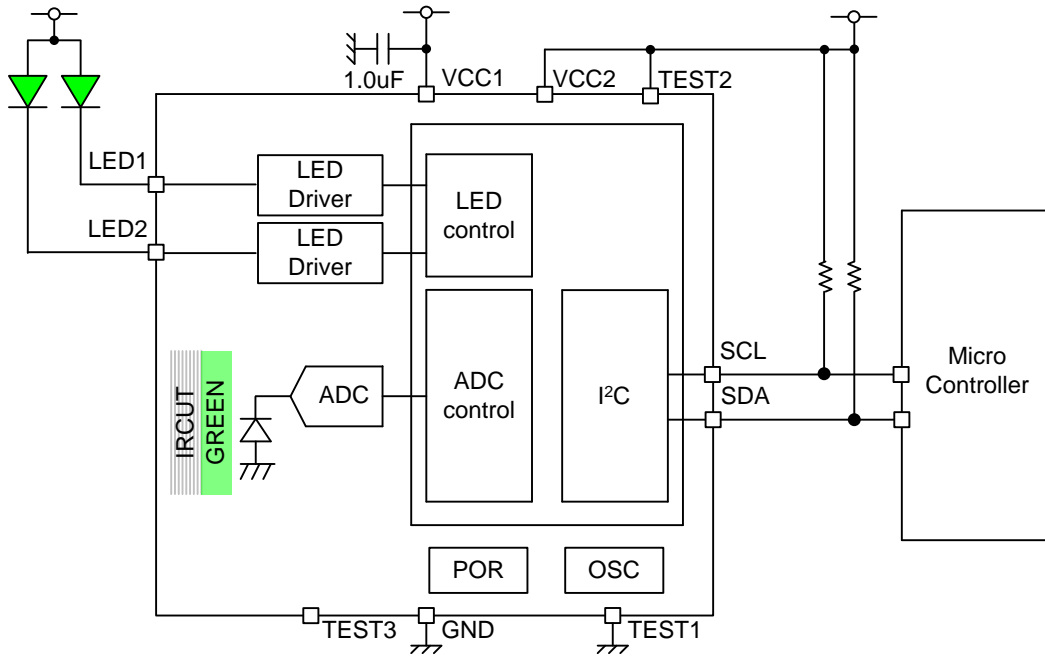

I/O equivalent circuit

PIN No.	Pin Name	Equivalent Circuit Diagram
1	VCC1	
2	GND	
3	LED1	
4	LED2	
5	TEST1	
6	TEST3	
7	TEST2	
8	VCC2	
9	SDA	
10	SCL	

Operational Notes

1. Reverse Connection of Power Supply

Connecting the power supply in reverse polarity can damage the IC. Take precautions against reverse polarity when connecting the power supply, such as mounting an external diode between the power supply and the IC's power supply terminals.

2. Power Supply Lines

Design the PCB layout pattern to provide low impedance supply lines. Separate the ground and supply lines of the digital and analog blocks to prevent noise in the ground and supply lines of the digital block from affecting the analog block. Furthermore, connect a capacitor to ground at all power supply pins. Consider the effect of temperature and aging on the capacitance value when using electrolytic capacitors.

3. Ground Voltage

Ensure that no pins are at a voltage below that of the ground pin at any time, even during transient condition.

4. Ground Wiring Pattern

When using both small-signal and large-current ground traces, the two ground traces should be routed separately but connected to a single ground at the reference point of the application board to avoid fluctuations in the small-signal ground caused by large currents. Also ensure that the ground traces of external components do not cause variations on the ground voltage. The ground lines must be as short and thick as possible to reduce line impedance.

5. Thermal Consideration

Should by any chance the maximum junction temperature rating be exceeded the rise in temperature of the chip may result in deterioration of the properties of the chip. In case of exceeding this absolute maximum rating, increase the board size and copper area to prevent exceeding the maximum junction temperature rating.

6. Recommended Operating Conditions

These conditions represent a range within which the expected characteristics of the IC can be approximately obtained. The electrical characteristics are guaranteed under the conditions of each parameter.

7. Rush Current

When power is first supplied to the IC, it is possible that the internal logic may be unstable and inrush current may flow instantaneously due to the internal powering sequence and delays, especially if the IC has more than one power supply. Therefore, give special consideration to power coupling capacitance, power wiring, width of ground wiring, and routing of connections.

8. Operation Under Strong Electromagnetic Field

Operating the IC in the presence of a strong electromagnetic field may cause the IC to malfunction.

9. Testing on Application Boards

When testing the IC on an application board, connecting a capacitor directly to a low-impedance output pin may subject the IC to stress. Always discharge capacitors completely after each process or step. The IC's power supply should always be turned off completely before connecting or removing it from the test setup during the inspection process. To prevent damage from static discharge, ground the IC during assembly and use similar precautions during transport and storage.

10. Inter-pin Short and Mounting Errors

Ensure that the direction and position are correct when mounting the IC on the PCB. Incorrect mounting may result in damaging the IC. Avoid nearby pins being shorted to each other especially to ground, power supply and output pin. Inter-pin shorts could be due to many reasons such as metal particles, water droplets (in very humid environment) and unintentional solder bridge deposited in between pins during assembly to name a few.

Operational Notes – continued

11. Unused Input Terminals

Input terminals of an IC are often connected to the gate of a MOS transistor. The gate has extremely high impedance and extremely low capacitance. If left unconnected, the electric field from the outside can easily charge it. The small charge acquired in this way is enough to produce a significant effect on the conduction through the transistor and cause unexpected operation of the IC. So unless otherwise specified, unused input terminals should be connected to the power supply or ground line.

12. Regarding the Input Pin of the IC

This monolithic IC contains P+ isolation and P substrate layers between adjacent elements in order to keep them isolated. P-N junctions are formed at the intersection of the P layers with the N layers of other elements, creating a parasitic diode or transistor. For example (refer to figure below):

When $GND > Pin A$ and $GND > Pin B$, the P-N junction operates as a parasitic diode.

When $GND > Pin B$, the P-N junction operates as a parasitic transistor.

Parasitic diodes inevitably occur in the structure of the IC. The operation of parasitic diodes can result in mutual interference among circuits, operational faults, or physical damage. Therefore, conditions that cause these diodes to operate, such as applying a voltage lower than the GND voltage to an input pin (and thus to the P substrate) should be avoided.

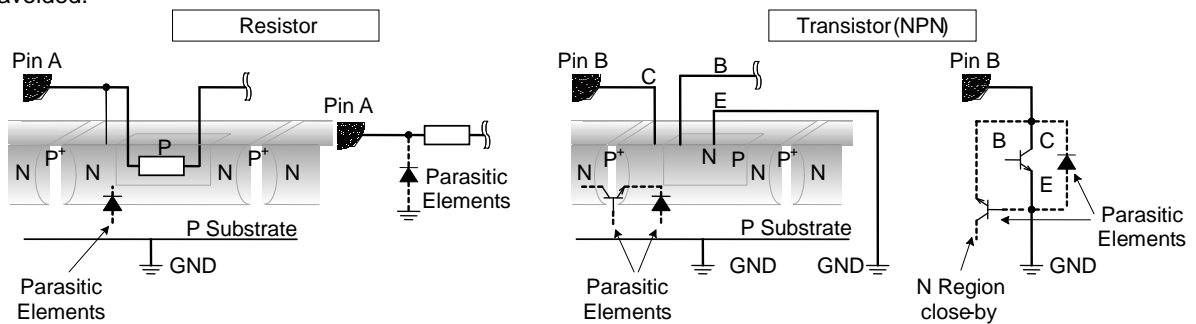

Figure xx. Example of monolithic IC structure

13. Ceramic Capacitor

When using a ceramic capacitor, determine the dielectric constant considering the change of capacitance with temperature and the decrease in nominal capacitance due to DC bias and others.

14. Area of Safe Operation (ASO)

Operate the IC such that the output voltage, output current, and power dissipation are all within the Area of Safe Operation (ASO).

Ordering information

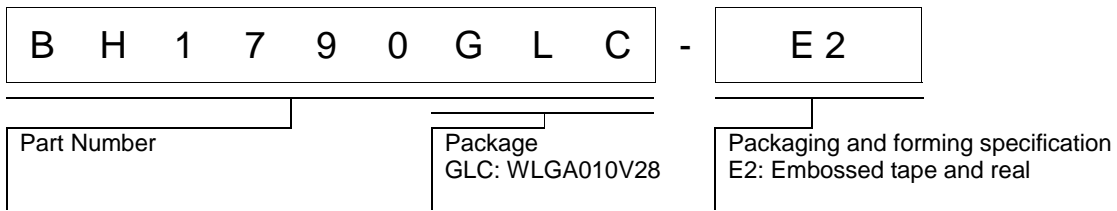

Marking Diagram

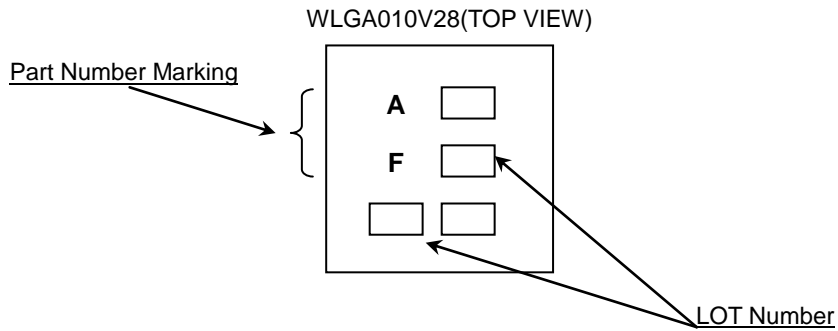

Optical design for the device

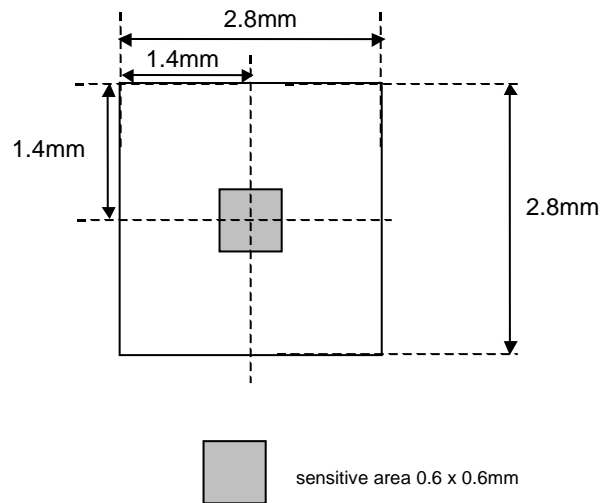

Physical Dimension, Tape and Reel Information

Package Name	WLGA010V28
--------------	------------

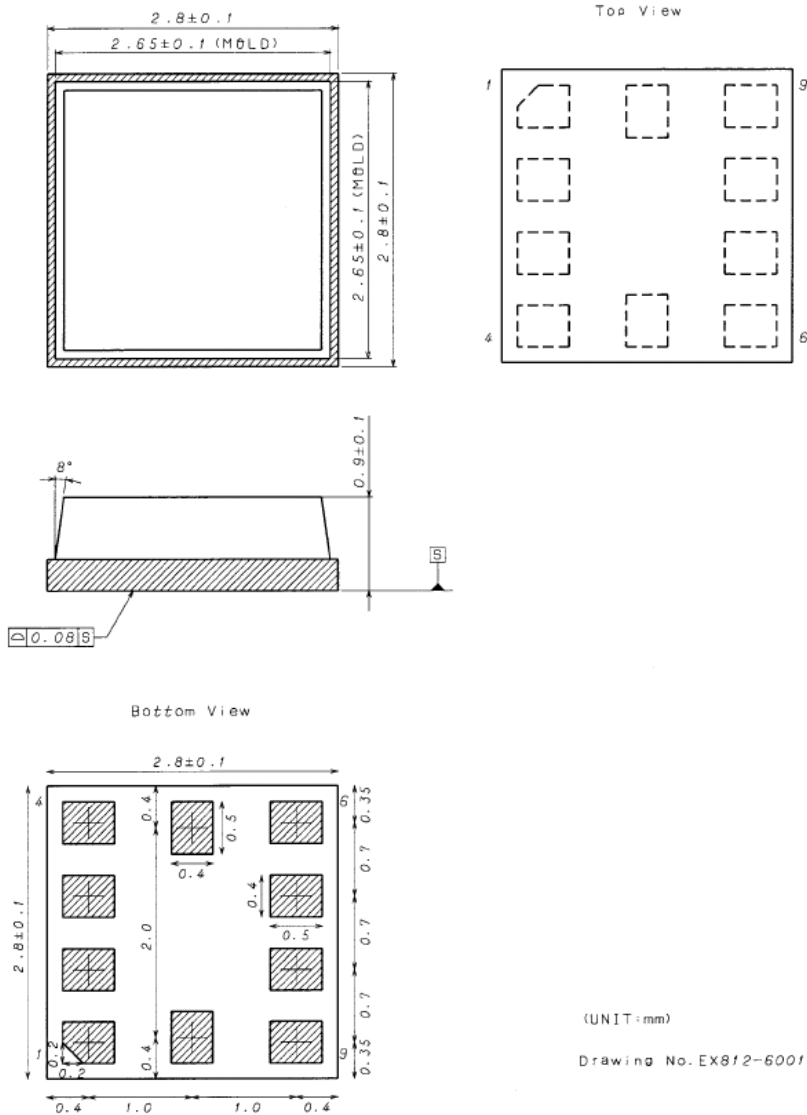

<Tape and Reel information>

Tape	Embossed carrier tape (with dry pack)
Quantity	3000pcs
Direction of feed	E2 (The direction is the 1pin of product is at the upper left when you hold reel on the left hand and you pull out the tape on the right hand)

Reel → 1pin → Direction of feed →

*Order quantity needs to be multiple of the minimum quantity.

Revision History

Date	Revision	Changes
01.Feb.2016	001	New Release
14.Mar.2016	002	modify Typical Application Circuit modify Pin Description modify Description of Blocks modify Electrical Characteristics modify Measurement Sequence modify Application Example
9.June.2016	003	Modify Thermal Resistance
1.Feb.2017	004	Modify Title Modify Annotation of Electrical Characteristics

Notice

Precaution on using ROHM Products

- Our Products are designed and manufactured for application in ordinary electronic equipments (such as AV equipment, OA equipment, telecommunication equipment, home electronic appliances, amusement equipment, etc.). If you intend to use our Products in devices requiring extremely high reliability (such as medical equipment ^(Note 1), transport equipment, traffic equipment, aircraft/spacecraft, nuclear power controllers, fuel controllers, car equipment including car accessories, safety devices, etc.) and whose malfunction or failure may cause loss of human life, bodily injury or serious damage to property ("Specific Applications"), please consult with the ROHM sales representative in advance. Unless otherwise agreed in writing by ROHM in advance, ROHM shall not be in any way responsible or liable for any damages, expenses or losses incurred by you or third parties arising from the use of any ROHM's Products for Specific Applications.

(Note1) Medical Equipment Classification of the Specific Applications

JAPAN	USA	EU	CHINA
CLASS III	CLASS III	CLASS II b	CLASS III
CLASS IV		CLASS III	

- ROHM designs and manufactures its Products subject to strict quality control system. However, semiconductor products can fail or malfunction at a certain rate. Please be sure to implement, at your own responsibilities, adequate safety measures including but not limited to fail-safe design against the physical injury, damage to any property, which a failure or malfunction of our Products may cause. The following are examples of safety measures:
 - Installation of protection circuits or other protective devices to improve system safety
 - Installation of redundant circuits to reduce the impact of single or multiple circuit failure
- Our Products are designed and manufactured for use under standard conditions and not under any special or extraordinary environments or conditions, as exemplified below. Accordingly, ROHM shall not be in any way responsible or liable for any damages, expenses or losses arising from the use of any ROHM's Products under any special or extraordinary environments or conditions. If you intend to use our Products under any special or extraordinary environments or conditions (as exemplified below), your independent verification and confirmation of product performance, reliability, etc. prior to use, must be necessary:
 - Use of our Products in any types of liquid, including water, oils, chemicals, and organic solvents
 - Use of our Products outdoors or in places where the Products are exposed to direct sunlight or dust
 - Use of our Products in places where the Products are exposed to sea wind or corrosive gases, including Cl₂, H₂S, NH₃, SO₂, and NO₂
 - Use of our Products in places where the Products are exposed to static electricity or electromagnetic waves
 - Use of our Products in proximity to heat-producing components, plastic cords, or other flammable items
 - Sealing or coating our Products with resin or other coating materials
 - Use of our Products without cleaning residue of flux (even if you use no-clean type fluxes, cleaning residue of flux is recommended); or Washing our Products by using water or water-soluble cleaning agents for cleaning residue after soldering
 - Use of the Products in places subject to dew condensation
- The Products are not subject to radiation-proof design.
- Please verify and confirm characteristics of the final or mounted products in using the Products.
- In particular, if a transient load (a large amount of load applied in a short period of time, such as pulse. is applied, confirmation of performance characteristics after on-board mounting is strongly recommended. Avoid applying power exceeding normal rated power; exceeding the power rating under steady-state loading condition may negatively affect product performance and reliability.
- De-rate Power Dissipation depending on ambient temperature. When used in sealed area, confirm that it is the use in the range that does not exceed the maximum junction temperature.
- Confirm that operation temperature is within the specified range described in the product specification.
- ROHM shall not be in any way responsible or liable for failure induced under deviant condition from what is defined in this document.

Precaution for Mounting / Circuit board design

- When a highly active halogenous (chlorine, bromine, etc.) flux is used, the residue of flux may negatively affect product performance and reliability.
- In principle, the reflow soldering method must be used on a surface-mount products, the flow soldering method must be used on a through hole mount products. If the flow soldering method is preferred on a surface-mount products, please consult with the ROHM representative in advance.

For details, please refer to ROHM Mounting specification

Precautions Regarding Application Examples and External Circuits

1. If change is made to the constant of an external circuit, please allow a sufficient margin considering variations of the characteristics of the Products and external components, including transient characteristics, as well as static characteristics.
2. You agree that application notes, reference designs, and associated data and information contained in this document are presented only as guidance for Products use. Therefore, in case you use such information, you are solely responsible for it and you must exercise your own independent verification and judgment in the use of such information contained in this document. ROHM shall not be in any way responsible or liable for any damages, expenses or losses incurred by you or third parties arising from the use of such information.

Precaution for Electrostatic

This Product is electrostatic sensitive product, which may be damaged due to electrostatic discharge. Please take proper caution in your manufacturing process and storage so that voltage exceeding the Products maximum rating will not be applied to Products. Please take special care under dry condition (e.g. Grounding of human body / equipment / solder iron, isolation from charged objects, setting of Ionizer, friction prevention and temperature / humidity control).

Precaution for Storage / Transportation

1. Product performance and soldered connections may deteriorate if the Products are stored in the places where:
 - [a] the Products are exposed to sea winds or corrosive gases, including Cl₂, H₂S, NH₃, SO₂, and NO₂
 - [b] the temperature or humidity exceeds those recommended by ROHM
 - [c] the Products are exposed to direct sunshine or condensation
 - [d] the Products are exposed to high Electrostatic
2. Even under ROHM recommended storage condition, solderability of products out of recommended storage time period may be degraded. It is strongly recommended to confirm solderability before using Products of which storage time is exceeding the recommended storage time period.
3. Store / transport cartons in the correct direction, which is indicated on a carton with a symbol. Otherwise bent leads may occur due to excessive stress applied when dropping of a carton.
4. Use Products within the specified time after opening a humidity barrier bag. Baking is required before using Products of which storage time is exceeding the recommended storage time period.

Precaution for Product Label

A two-dimensional barcode printed on ROHM Products label is for ROHM's internal use only.

Precaution for Disposition

When disposing Products please dispose them properly using an authorized industry waste company.

Precaution for Foreign Exchange and Foreign Trade act

Since concerned goods might be fallen under listed items of export control prescribed by Foreign exchange and Foreign trade act, please consult with ROHM in case of export.

Precaution Regarding Intellectual Property Rights

1. All information and data including but not limited to application example contained in this document is for reference only. ROHM does not warrant that foregoing information or data will not infringe any intellectual property rights or any other rights of any third party regarding such information or data.
2. ROHM shall not have any obligations where the claims, actions or demands arising from the combination of the Products with other articles such as components, circuits, systems or external equipment (including software).
3. No license, expressly or implied, is granted hereby under any intellectual property rights or other rights of ROHM or any third parties with respect to the Products or the information contained in this document. Provided, however, that ROHM will not assert its intellectual property rights or other rights against you or your customers to the extent necessary to manufacture or sell products containing the Products, subject to the terms and conditions herein.

Other Precaution



1. This document may not be reprinted or reproduced, in whole or in part, without prior written consent of ROHM.
2. The Products may not be disassembled, converted, modified, reproduced or otherwise changed without prior written consent of ROHM.
3. In no event shall you use in any way whatsoever the Products and the related technical information contained in the Products or this document for any military purposes, including but not limited to, the development of mass-destruction weapons.
4. The proper names of companies or products described in this document are trademarks or registered trademarks of ROHM, its affiliated companies or third parties.

General Precaution



1. Before you use our Products, you are requested to carefully read this document and fully understand its contents. ROHM shall not be in any way responsible or liable for failure, malfunction or accident arising from the use of any ROHM's Products against warning, caution or note contained in this document.
2. All information contained in this document is current as of the issuing date and subject to change without any prior notice. Before purchasing or using ROHM's Products, please confirm the latest information with a ROHM sales representative.
3. The information contained in this document is provided on an "as is" basis and ROHM does not warrant that all information contained in this document is accurate and/or error-free. ROHM shall not be in any way responsible or liable for any damages, expenses or losses incurred by you or third parties resulting from inaccuracy or errors of or concerning such information.

Looking for pricing, stock, or lifecycle information?

Click below to explore more details on WIN SOURCE:

-  [View BH1790GLC-E2 on WIN SOURCE](#)
-  [Rohm Semiconductor](#) Information

Optimize Your Supply Chain with WIN SOURCE Solutions

-  Global Sourcing Solution
-  Obsolete Management
-  Cost Control Management
-  Shortage Management
-  Alternative Solution
-  Excess Inventory Management