

# ROHM Sensor Shield Manual

Jun 09, 2016  
Sensor Application G

# Sensor board lineup

No.	Sensor	Type Name
1	Accelerometer	KX022-1020
2	Pressure sensor	BM1383GLV
3	Magnetic sensor	BM1422GMV
4	ALS/PS sensor	RPR-0521RS
5	Color sensor	BH1745NUC
6	Hall sensor	BD7411G
7	Temperature sensor	BD1020HFV
8	UV sensor	ML8511A

# ROHM Sensor Shield

- Shield for Arduino Uno
- Size: 88mm x 63mm
- I/F: I2C/Analog/Digital
- Operation Voltage: 5V, 3V and 1.8V
  - Embedded Level Shifter
  - GPIO : FAIRCHILD FXMA108
  - I2C : NXP PCA9306
- I2C pull-up register

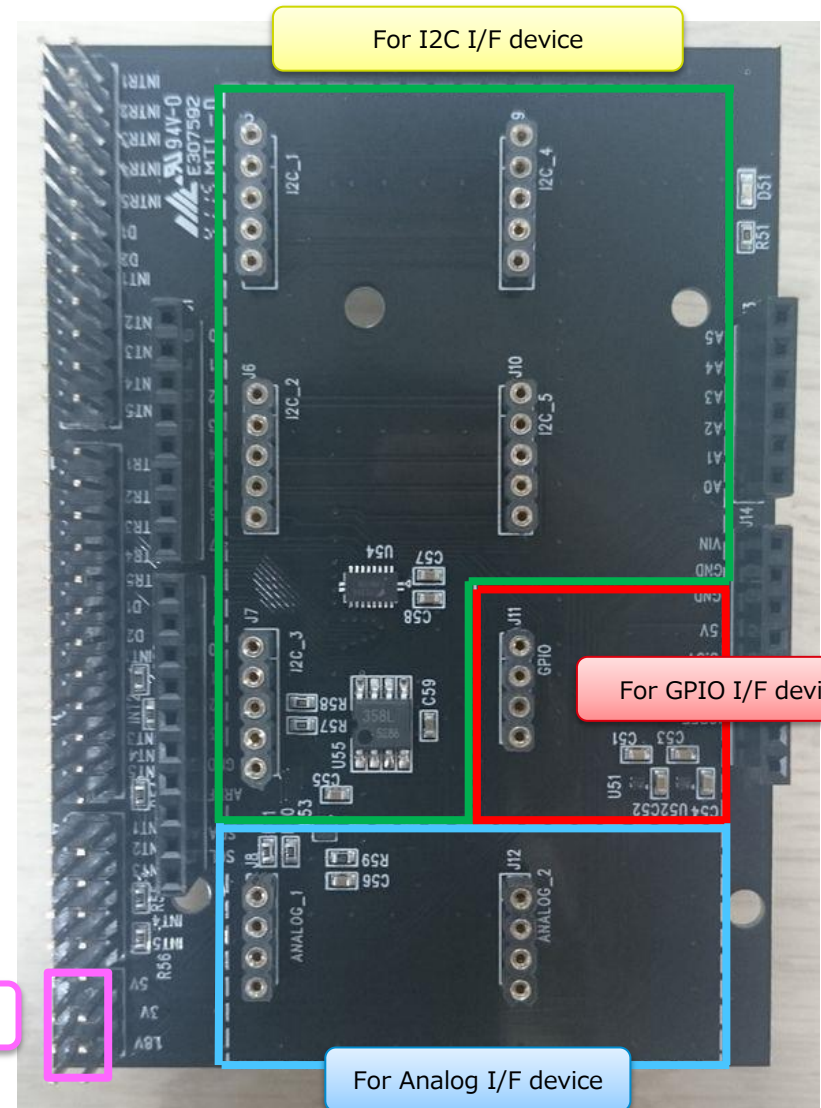

# Feature of each sensor board

- Through Hall: I/F pin, VDD and GND Pin (Fig.1)
- Board Size: 20mm x 20mm
- Board Color: Black
- The board has pattern to change Slave address.(Fig.2)
  - KX022-1020, BM1422GMV, BH1745NUC
- M3 Size Hole to attached some device.

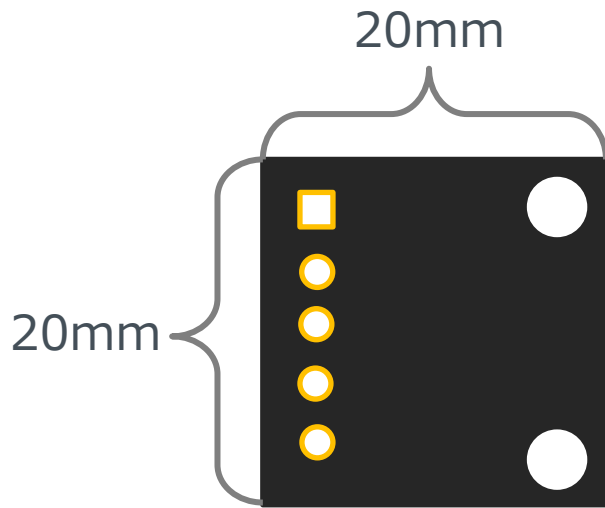

Fig.1

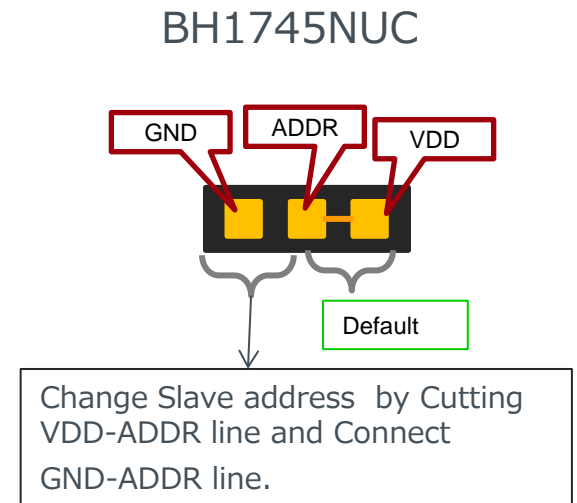
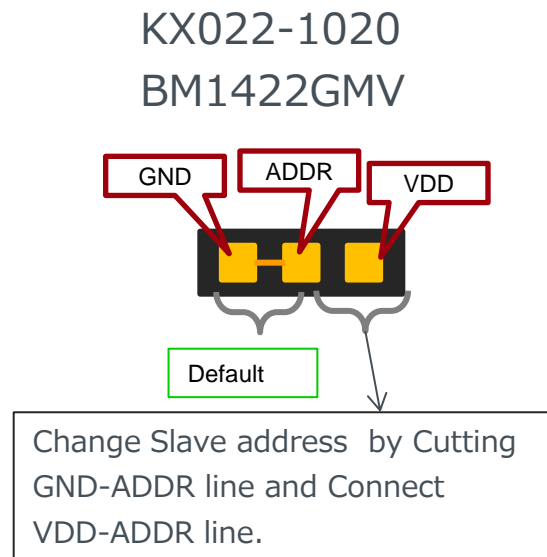

Fig.2

## 1. Connect between Arduino and Sensor Shield

USB  
Connector



## 2. Select Sensor Board which connect to Sensor Shield

ex) Connect BM1383GLV to I2C\_1

## 3. Voltage Setting of Sensor Shield

ex) 1.8V

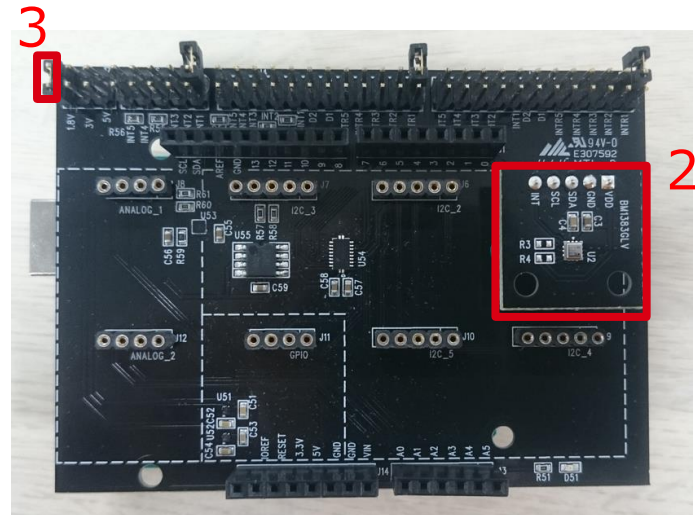

## 4. Connect PC to Arduino by USB Cable

## 5. Copy Arduino program to libraries of Arduino

- Recommended system requirements : Arduino IDE version 1.6.7 or above
- Please download Arduino IDE from <http://www.arduino.cc>

## 6. Execute Arduino IDE(v1.6.7)

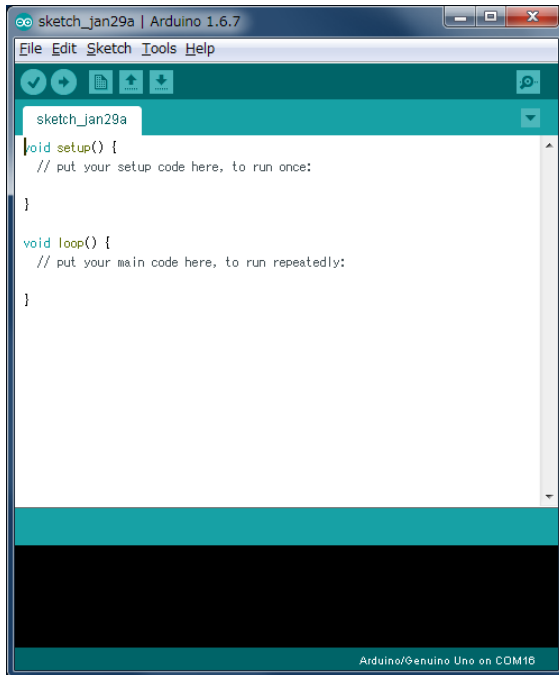

## 7. Select Program

- File->Examples->BM1383GLV->example->BM1383GLV

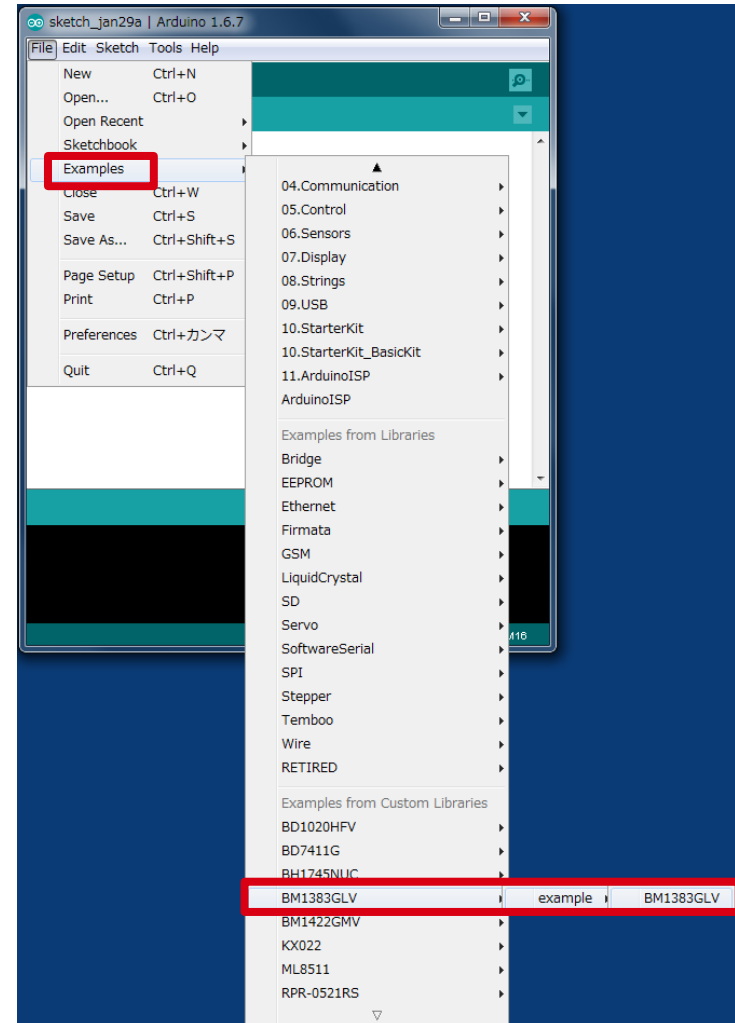

## 8. Change Setting of Board and Port

- (1) Tools->Board ⇒ "Arduino/Genuino Uno",
- (2) Port ⇒ "COMxx(Arduino/Genuino Uno)"

COM Port Number depends on PC.

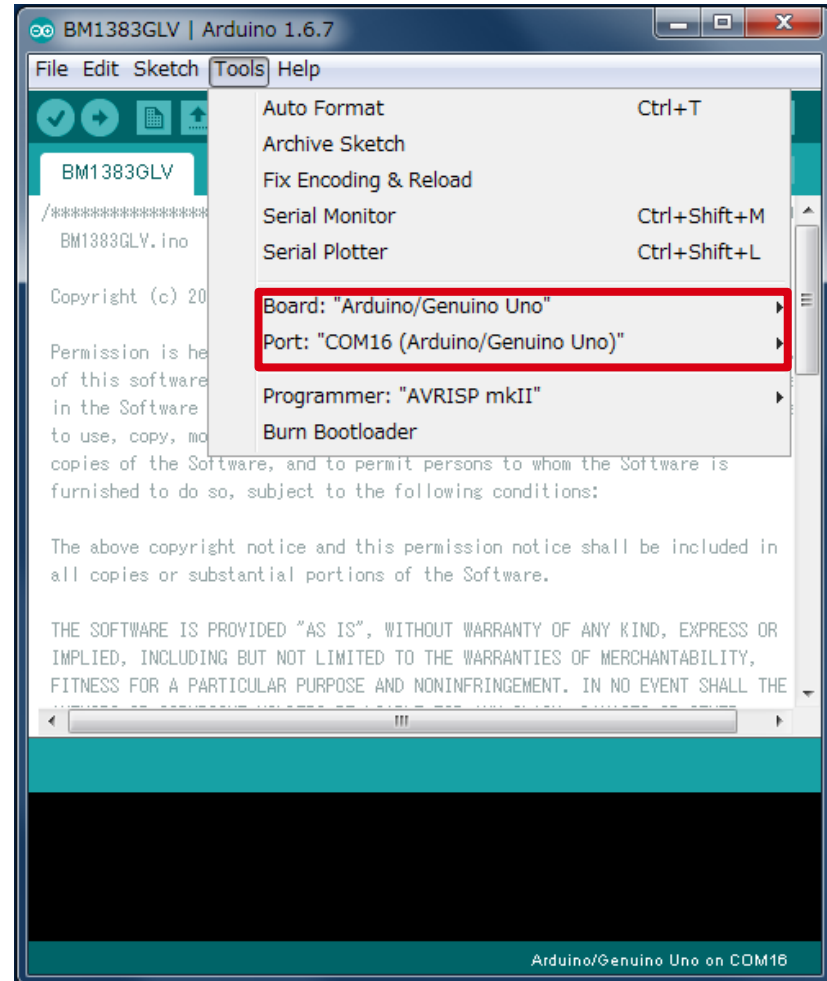

## 9. Write Program (Push Upload Button)

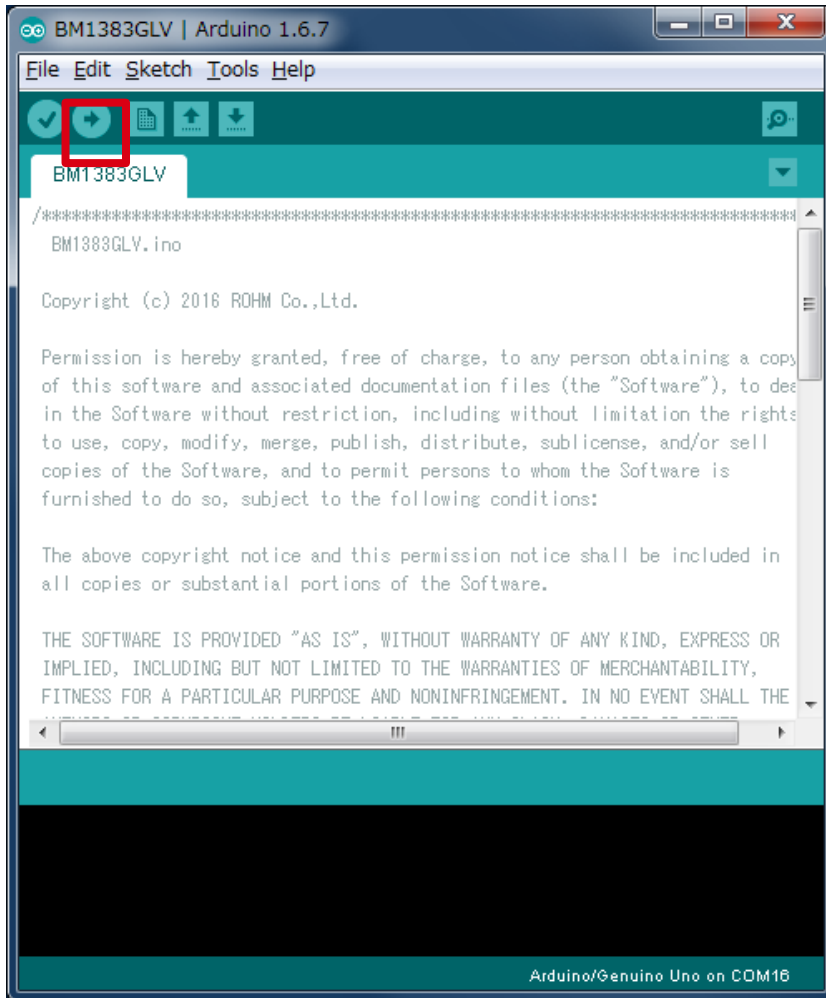

## 10. Check status whether Write Program is OK or Not. OK log is "Done uploading".

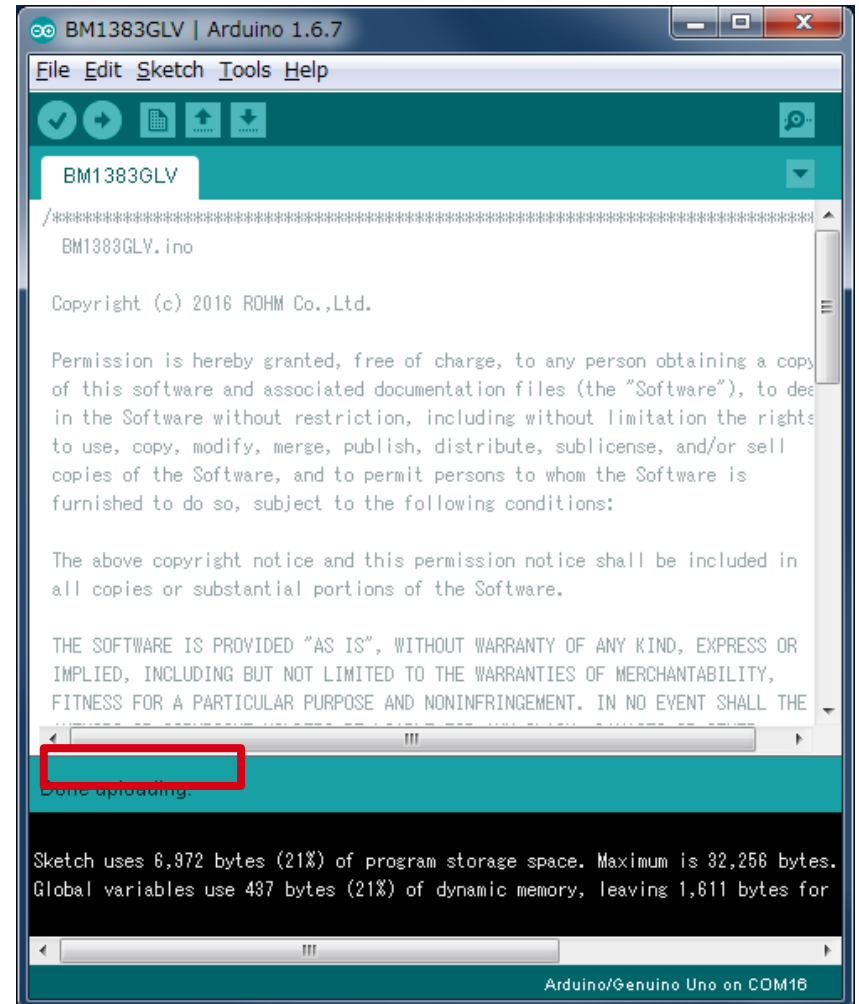

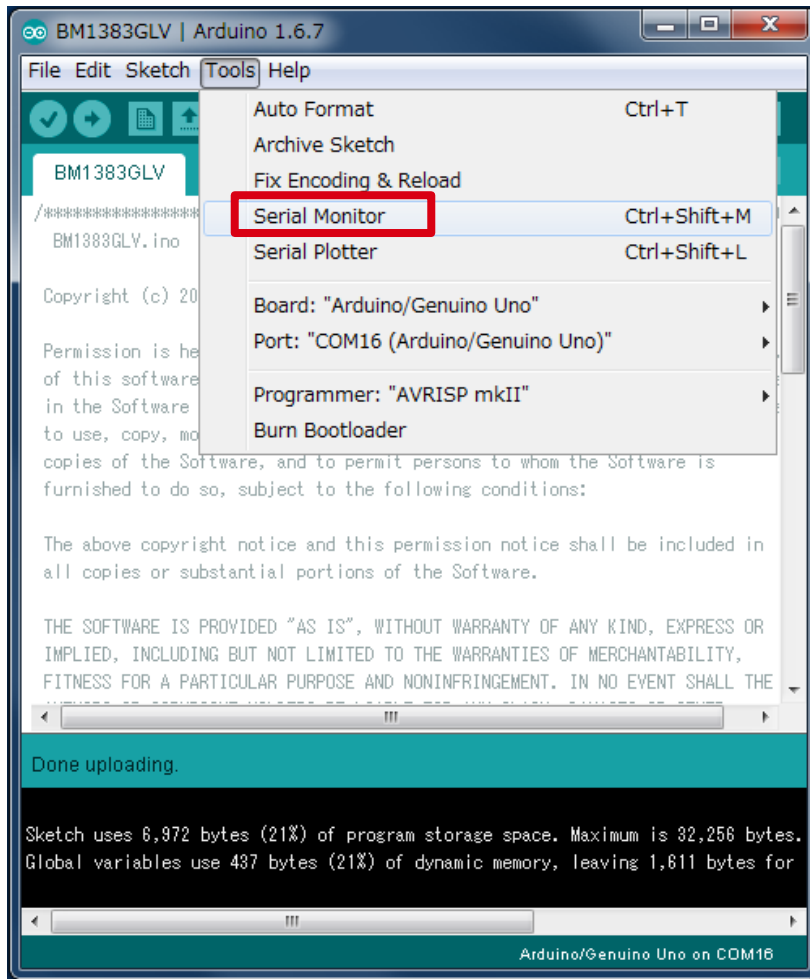

## 11. Select Tools->Serial Monitor

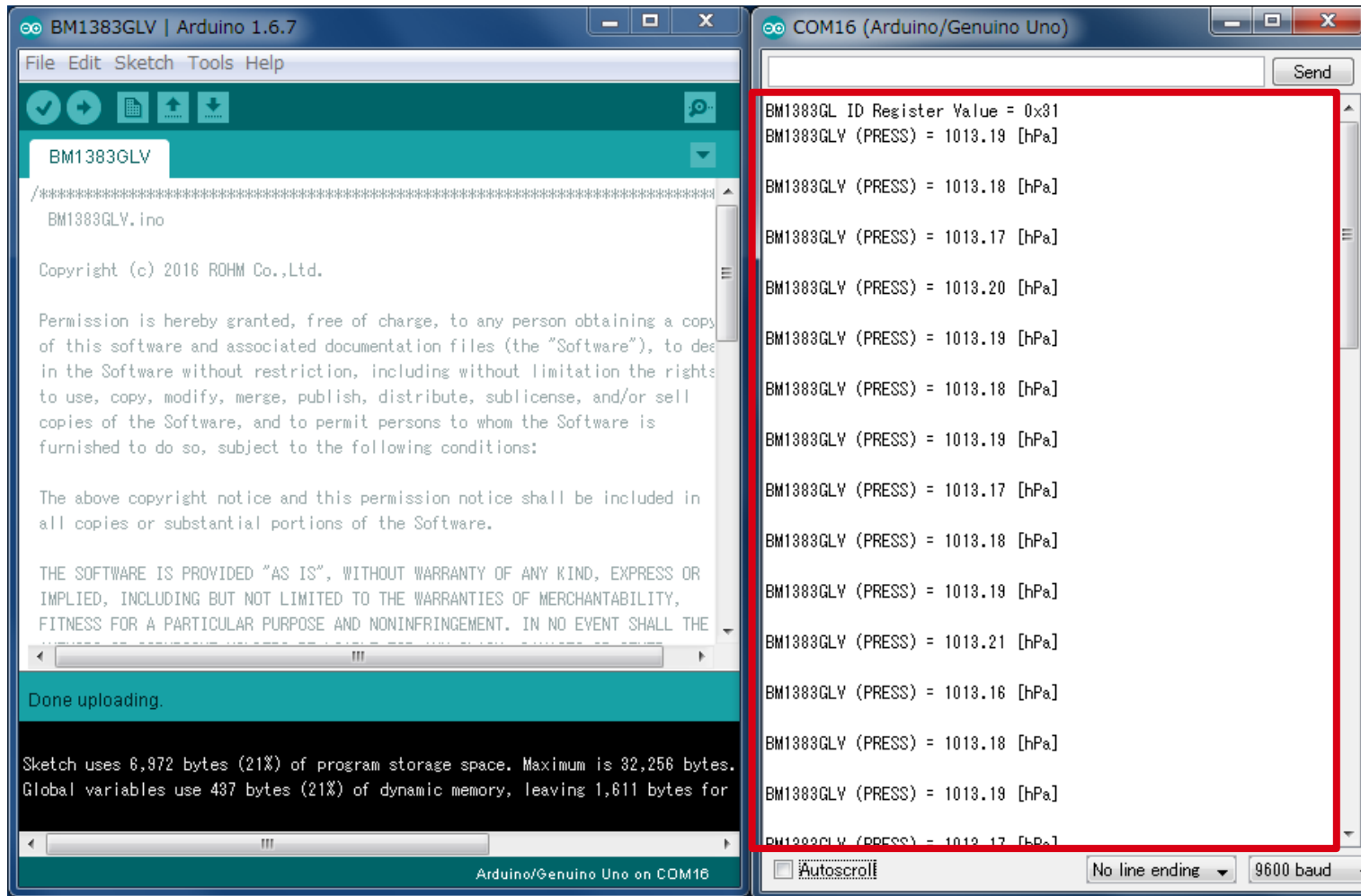

## 12. Check log of Serial Monitor

# In the case of I2C I/F (KX022) I2C

[Program]  
File->Examples->  
KX022->example->  
KX022

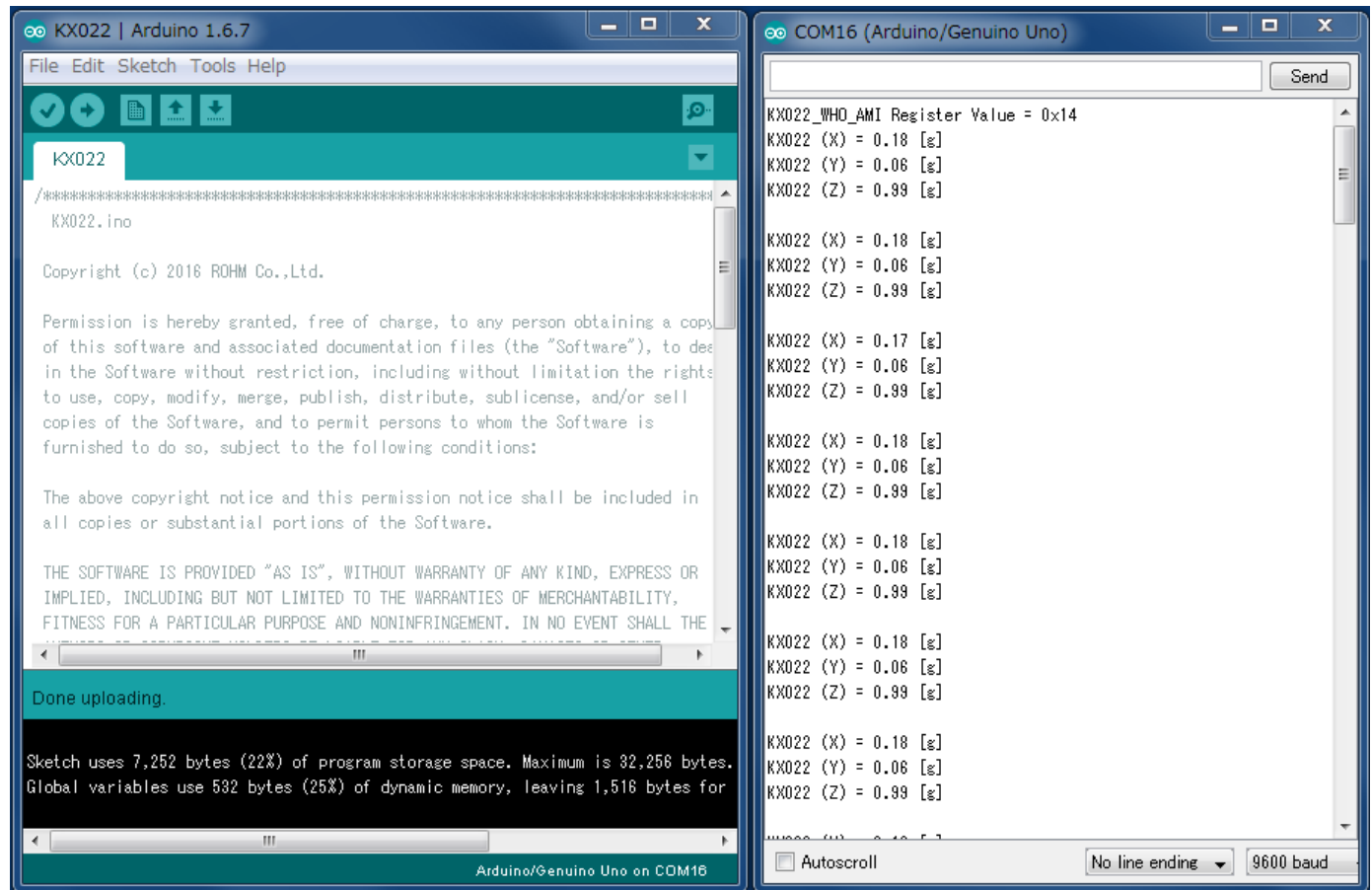

[Result of Sample Program]  
Display output data of X, Y, and Z axis at 500ms interval.

# In the case of GPIO I/F (BD7411)

[Program]

File->Examples->  
BD7411G->example->  
BD7411

※Caution

When Sample program  
of BD7411 is installed,  
Take off BD7411 Sensor  
Board.

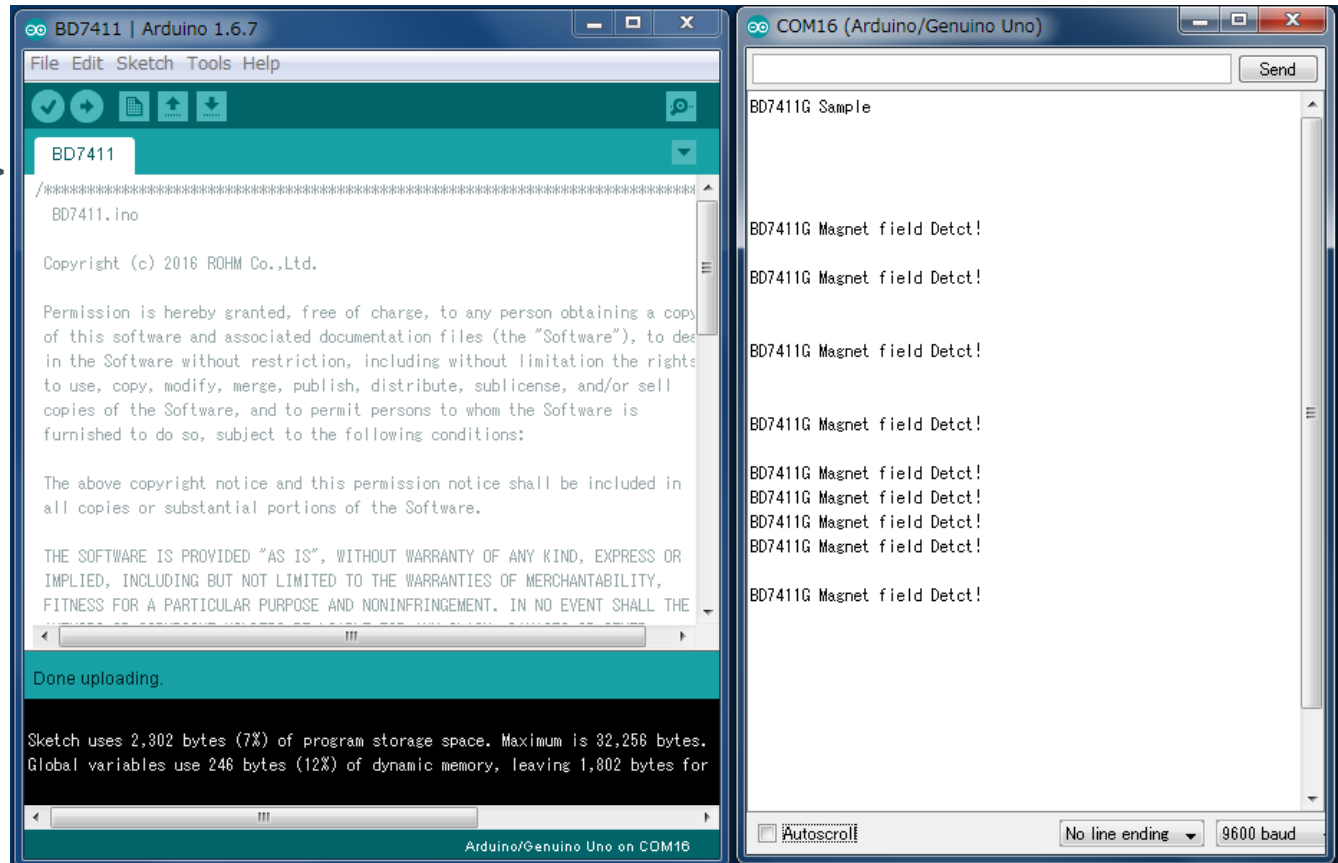

[Result of Sample Program]

Display message at 500ms interval when BD7411 output is low.

# In the case Analog I/F (BD1020)

[Program]

File->Examples->

BD1020HFV->example->

BD1020

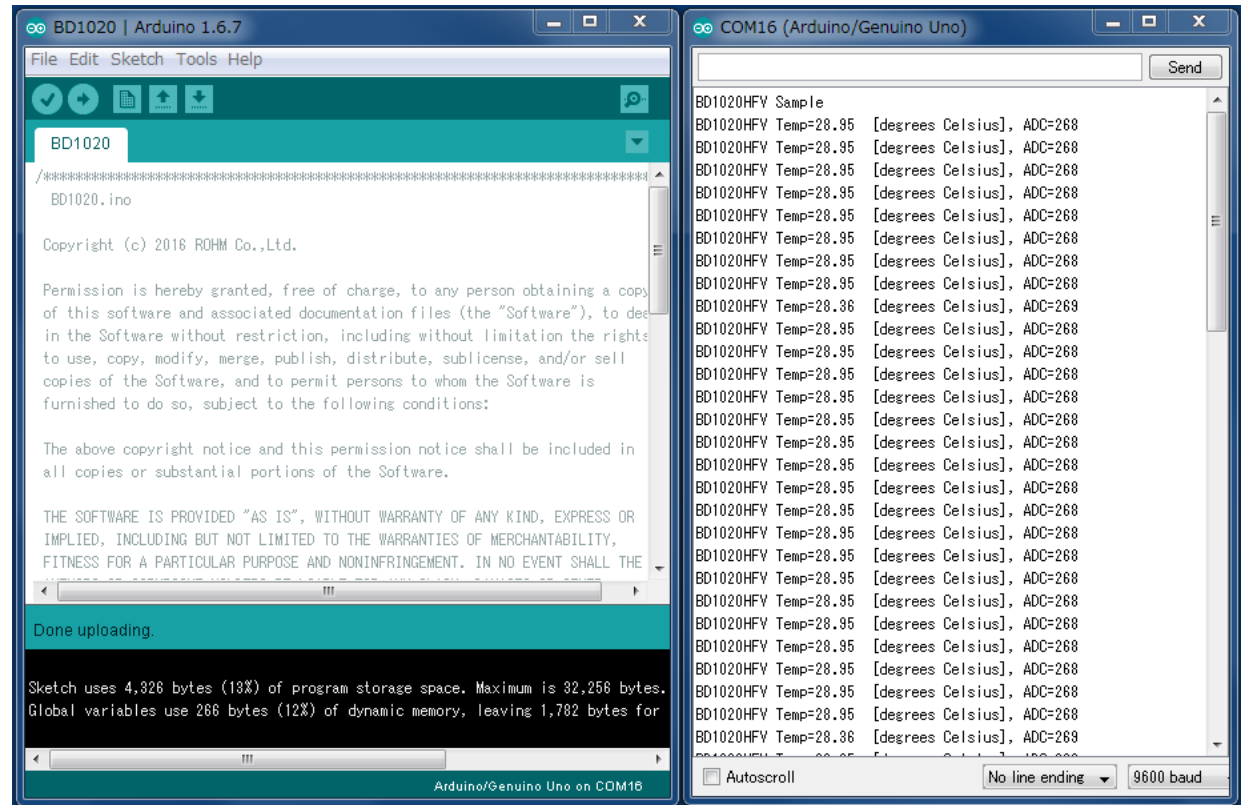

[Result of Sample Program]

Display output data of Temperature sensor at 500ms interval.

# Connection Point of Sample Program

No.	Sensor	Type Name	
1	Accelerometer	KX022-1020	I2C_1,I2C_2,I2C_3,I2C_4,I2C_5
2	Pressure sensor	BM1383GLV	I2C_1,I2C_2,I2C_3,I2C_4,I2C_5
3	Magnetic sensor	BM1422GMV	I2C_1,I2C_2,I2C_3,I2C_4,I2C_5
4	ALS/PS sensor	RPR-0521RS	I2C_1,I2C_2,I2C_3,I2C_4,I2C_5
5	Color sensor	BH1745NUC	I2C_1,I2C_2,I2C_3,I2C_4,I2C_5
6	Hall sensor	BD7411G	GPIO
7	Temperature sensor	BD1020HFV	ANALOG_2
8	UV sensor	ML8511A	ANALOG_1

# Selectable Power Supply

No.	Sensor	Type Name		Recommended Operating Voltage [V]			Selectable Power [V]		
				Min.	Typ.	Max	1.8	3	5
1	Accelerometer	KX022-1020	Vdd	1.71	2.5	3.6	○	○	
			Vio	1.7	-	Vdd			
2	Pressure sensor	BM1383GLV	VDD	1.7	-	3.6	○	○	
3	Magnetic sensor	BM1422GMV	AVDD	1.7	-	2.0	○		
			DVDD	1.7	-	2.0			
4	ALS/PS sensor	RPR-0521RS	VCC	2.5	3.0	3.6		○	
			VLEDA	2.8	3.0	5.5			
5	Color sensor	BH1745NUC	Vcc	2.3	2.5	3.6		○	
6	Hall sensor	BD7411G	VDD	4.5	5.0	5.5			○
7	Temperature sensor	BD1020HFV	VDD	2.4	3.0	5.5		○	○
8	UV sensor	ML8511A	VDD	2.7	3.3	3.6		○	

# I2C Device Address List

No.	Sensor	Type Name	Device Address(7bit)
1	Accelerometer	KX022-1020	0x1E/0x1F
2	Pressure sensor	BM1383GLV	0x5D
3	Magnetic sensor	BM1422GMV	0x0E/0x0F
4	ALS/PS sensor	RPR-0521RS	0x38
5	Color sensor	BH1745NUC	0x38/0x39

Blue character is default slave address



## Looking for pricing, stock, or lifecycle information?

Click below to explore more details on WIN SOURCE:

- ⊖ [View SENSORSHIELD-EVK-001 on WIN SOURCE](#)
- ⊖ [Rohm Semiconductor](#) Information

## Optimize Your Supply Chain with WIN SOURCE Solutions

- ✓ Global Sourcing Solution
- ✓ Obsolete Management
- ✓ Cost Control Management
- ✓ Shortage Management
- ✓ Alternative Solution
- ✓ Excess Inventory Management