

Structure	Silicon Monolithic Integrated Circuit
Product Series	4ch Sensorless System Motor Driver for MD
Type	BD6640KVT
Features	<ul style="list-style-type: none"> • Operates at low power supply voltage (2.1V min) • Power DMOS output with low ON resistance (0.8Ω Typ.) • Incorporates a charge pump circuit for VG boost. • 3-phase full-wave soft-switching sensorless driver for spindle • 3-value control 3-phase driver for sled (built-in comparator for BEMF voltage detection) • 2ch, 3-value control H-bridges for focus/tracking • PWM half-bridge for spindle VM power supply

○Absolute maximum ratings(Ta=25°C)

Parameter	Symbol	Limit	Unit
Power supply voltage for control circuit	VCC	7	V
Power supply voltage for driver block	VM	7	V
Power supply voltage for pre-driver block	VG	14	V
Input voltage	VIN	0~VCC	V
Output current	Iomax	*500	mA
Power dissipation	Pd	**1250	mW
Operating temperature range	Topr	-25~+75	°C
Storage temperature range	Tstg	-55~+150	°C
Junction temperature	Tjmax	+150	°C

* Must not exceed Pd or ASO, Tjmax=150°C.

* * Reduced by 10mW/°C over Ta=25°C, when mounted on a glass epoxy board (70mm×70 mm×1.6mm).

○Operating conditions (Ta=-25~+75°C)

Parameter	Symbol	Min.	Typ.	Max	Unit
Power supply voltage	VCC1,2	2.1	2.2	6.5	V
	VM	-	-	5.0	V
	VG	3	6.5	13	V
Pulse input frequency	fin	-	-	500	kHz

This product described in this specification is not judged whether it applies to COCOM regulations.

Please confirm in case of export.

This product is not designed for protection against radioactive rays.

○Electrical characteristics

(Unless otherwise specified, Ta=25°C, VCC1, 2=2.2V, VM=1.0V, fin=176kHz)

Parameter	Symbol	Limit			Unit	Conditions
		Min.	Typ.	Max.		
Circuit current	ICC	-	4.4	7.0	mA	at operation in all blocks
	IST	-	1	10	μA	at standby in all blocks
Output ON resistance	RON	-	0.8	1.2	Ω	upper and lower ON resistance in total VG=10V
~Boost circuit~						
Output voltage	VG1	5.5	6.5	6.7	V	each input L
	VG2	4.4	5.2	—	V	at operation in all blocks
~Oscillation circuit~						
Self-propelled oscillating frequency	fOSC	50	100	160	kHz	
External clock synchronous range	fSYNC	—	—	500	kHz	input from EXTCLK pin
~Spindle (3-phase full-wave sensorless driver) block~						
Position detection comparator	VCO	-10	—	+10	mV	
Detection comparator input range	VCD	0	—	VCC-	V	
CST charge current	ICTO	-3.5	-2.1	-0.9	μA	CST=1V
CST discharge current	ICTI	1.0	3.6	7.5	mA	CST=1V
CSL charge current	ICLO	-3.5	-7.5	-13	μA	CSL=0.5V
CSL discharge current	ICLI	1.2	3.0	6.5	μA	CSL=0.5V
CSL clamp H voltage	VCLH	0.7	0.8	0.9	V	
Brake comparator input current	IBR	—	—	2.0	μA	BRK=VCC
Brake comparator input offset	VBO	-15	—	+15	mV	
Brake comparator input range	VBD	0	—	VCC-1	V	
FG output pull-up resistance	RBF	10	20	30	kΩ	
FG output L voltage	VOLF	—	0.2	0.3	V	Io=300μA
RIB offset voltage	VRO	10	18	30	mV	VM=0V RIB=500Ω
Pre-drive loop gain	VRP	500	650	850	mV	
M-phase check	VMCK	400	500	600	mV	
~Sled, focus, tracking, PWM power supply (stepping, H-bridge, and half-bridge driver) block~						
Logic H level input voltage	VINH	VCC-0.4	—	VCC	V	
Logic L level input voltage	VINL	0	—	0.4	V	
Logic H level input current	IINH1	—	—	1	μA	VIN=2.2V
	IINH2	—	350	600	μA	VIN=2.2V EXTCLK pin
Logic L level input current	IINL	-1	—	—	μA	VIN=0V
Output propagation delay time	TRISE	—	0.2	1	μsec	
	TFALL	—	0.1	0.7	μsec	
Short pulse response	tmin	120	—	—	nsec	input pulse width 200 ns

©This product is not designed for protection against radioactive rays.

OPackage outlines

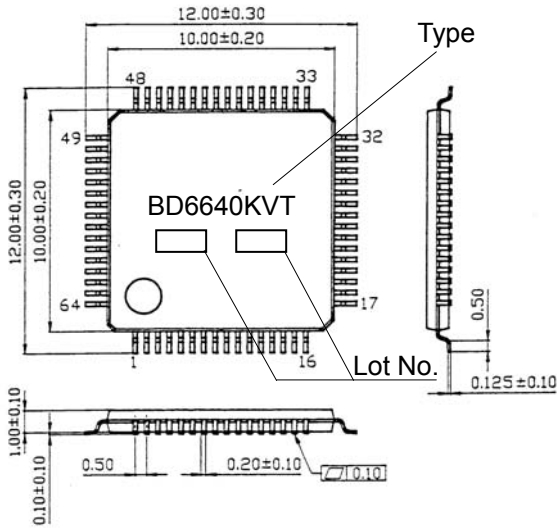

TQFP64V outlines (Unit : mm)

OBlock diagram

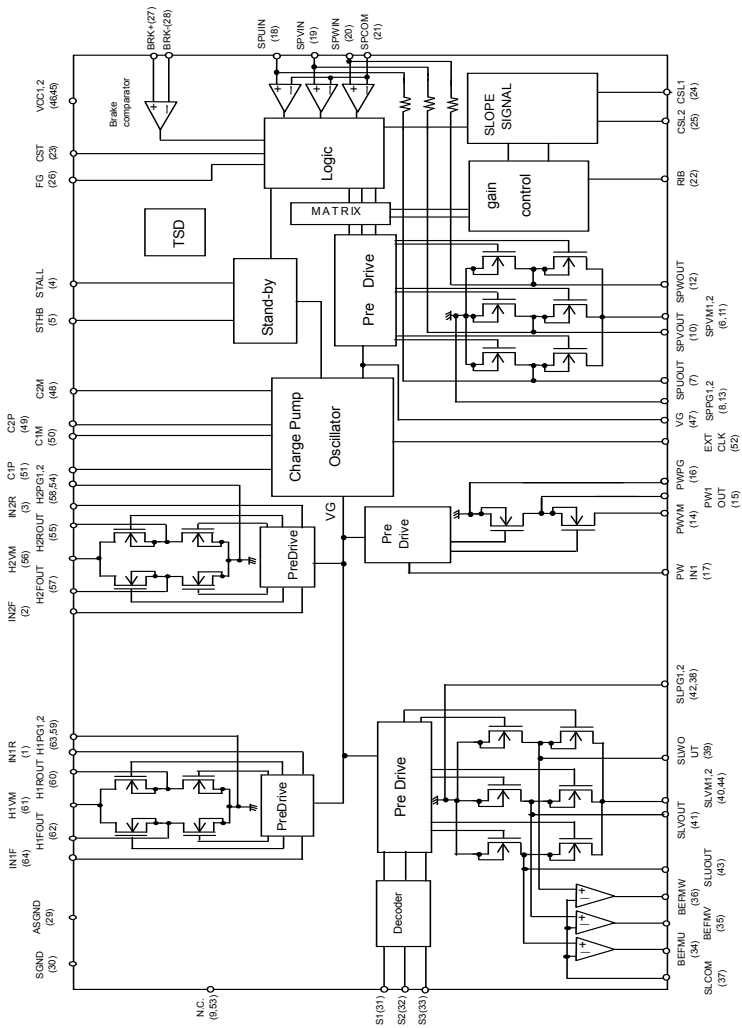

OPin No./Pin name

NO.	Pin name	NO.	Pin name
1	IN1R	33	S3
2	IN2F	34	BEMFU
3	IN2R	35	BEMFV
4	STALL	36	BEMFW
5	STHB	37	SLCOM
6	SPVM1	38	SLPG2
7	SPUOUT	39	SLWOUT
8	SPPG1	40	SLVM2
9	N.C	41	SLVOUT
10	SPVOUT	42	SLPG1
11	SPVM2	43	SLUOUT
12	SPWOUT	44	SLVM1
13	SPPG2	45	VCC2
14	PWVM	46	VCC1
15	PWOUT	47	VG
16	PWPG	48	C2M
17	PWWIN	49	C2P
18	SPUIN	50	C1M
19	SPVIN	51	C1P
20	SPWIN	52	EXTCLK
21	SPCOM	53	N.C
22	RIB	54	H2PG2
23	CST	55	H2ROUT
24	CSL1	56	H2VOUT
25	CSL2	57	H2FOUT
26	FG	58	H2PG1
27	BRK+	59	H1PG2
28	BRK-	60	H1ROUT
29	ASGND	61	H1VOUT
30	SGND	62	H1FOUT
31	S1	63	H1PG1
32	S2	64	IN1F

ONotes on the use

- (1) Absolute maximum ratings
If the input voltage or the operating temperature range exceeds absolute maximum ratings, IC may be damaged. No destruction mode (e.g., short-circuiting or open) can be specified in that case. If such special mode as will exceed absolute maximum ratings is assumed, take the physical safety measures, such as a fuse.
- (2) Power supply lines
The regenerated current by BEMF of the motor will return. Therefore, take measures, such as the insertion of a capacitor between the power supply and GND as the pass of the regenerated current. Determine the capacitance in full consideration of all the characteristics of the electrolytic capacitor, because the electrolytic capacitor may loose some capacitance at low temperatures. If the connected power supply does not have sufficient current absorption capacity, regenerative current will cause the voltage of the power supply line to rise, which the product and its peripheral circuit may exceed the absolute maximum ratings. It is recommended to implement physical safety measures such as the insertion of a voltage clamp diode between the power supply and GND pins.
- (3) Ground potential
Ensure a minimum GND pin potential in all operating conditions.
- (4) Design for heat
Use the design for heat that allows for a sufficient margin in light of the power dissipation (Pd) in actual using conditions.
- (5) Operation in strong magnetic field
Use caution when using the IC in the strong magnetic field as doing so may cause the IC to malfunction.
- (6) ASO
When using the IC, make settings so that the output transistors for the motor will not be used under conditions in excess of the absolute maximum ratings and ASO.
- (7) Thermal shutdown circuit
This IC incorporates thermal shutdown circuit(TSD circuit).
When the chip temperature becomes the one shown in below, TSD circuit operates and makes the coil output to motor open. It is designed to shut the IC off from runaway thermal operation. It is not designed to protect the IC or guarantee its operation. Do not continue to use the IC after operating this circuit or use the IC in an environment where the operation of this circuit is assumed.

TSD ON temperature[°C] (typ.)	Hysteresis temperature [°C] (typ.)
175	20

- (8) Ground wiring pattern
When having both small signal and large current GND, it is recommended to isolate the two GND patterns, placing a single ground point at the application's reference point so that the pattern wiring resistance and voltage variations caused by large currents do not cause voltage variations of the small signal GND. Be careful not to change the GND wiring pattern of any external parts, either.

Notes

No copying or reproduction of this document, in part or in whole, is permitted without the consent of ROHM Co.,Ltd.

The content specified herein is subject to change for improvement without notice.

The content specified herein is for the purpose of introducing ROHM's products (hereinafter "Products"). If you wish to use any such Product, please be sure to refer to the specifications, which can be obtained from ROHM upon request.

Examples of application circuits, circuit constants and any other information contained herein illustrate the standard usage and operations of the Products. The peripheral conditions must be taken into account when designing circuits for mass production.

Great care was taken in ensuring the accuracy of the information specified in this document. However, should you incur any damage arising from any inaccuracy or misprint of such information, ROHM shall bear no responsibility for such damage.

The technical information specified herein is intended only to show the typical functions of and examples of application circuits for the Products. ROHM does not grant you, explicitly or implicitly, any license to use or exercise intellectual property or other rights held by ROHM and other parties. ROHM shall bear no responsibility whatsoever for any dispute arising from the use of such technical information.

The Products specified in this document are intended to be used with general-use electronic equipment or devices (such as audio visual equipment, office-automation equipment, communication devices, electronic appliances and amusement devices).

The Products specified in this document are not designed to be radiation tolerant.

While ROHM always makes efforts to enhance the quality and reliability of its Products, a Product may fail or malfunction for a variety of reasons.

Please be sure to implement in your equipment using the Products safety measures to guard against the possibility of physical injury, fire or any other damage caused in the event of the failure of any Product, such as derating, redundancy, fire control and fail-safe designs. ROHM shall bear no responsibility whatsoever for your use of any Product outside of the prescribed scope or not in accordance with the instruction manual.

The Products are not designed or manufactured to be used with any equipment, device or system which requires an extremely high level of reliability the failure or malfunction of which may result in a direct threat to human life or create a risk of human injury (such as a medical instrument, transportation equipment, aerospace machinery, nuclear-reactor controller, fuel-controller or other safety device). ROHM shall bear no responsibility in any way for use of any of the Products for the above special purposes. If a Product is intended to be used for any such special purpose, please contact a ROHM sales representative before purchasing.

If you intend to export or ship overseas any Product or technology specified herein that may be controlled under the Foreign Exchange and the Foreign Trade Law, you will be required to obtain a license or permit under the Law.





Thank you for your accessing to ROHM product informations.
More detail product informations and catalogs are available, please contact us.

ROHM Customer Support System

<http://www.rohm.com/contact/>

Looking for pricing, stock, or lifecycle information?

Click below to explore more details on WIN SOURCE:

-  [View BD6640KUT-E2 on WIN SOURCE](#)
-  [Rohm Semiconductor](#) Information

Optimize Your Supply Chain with WIN SOURCE Solutions

-  Global Sourcing Solution
-  Obsolete Management
-  Cost Control Management
-  Shortage Management
-  Alternative Solution
-  Excess Inventory Management