

STRUCTURE Silicon Monolithic Integrated Circuit  
 TYPE High-Side Current-Sense Amplifier  
 PRODUCT SERIES **BD3181FVM**  
 FEATURES
 

- Input bias current < 100  $\mu$  A Max.
- High accurate output voltage gain (GV:50  $\pm$ 2%)

○ ABSOLUTE MAXIMUM RATINGS (Ta=25°C)

Parameter	Symbol	Limit	Unit
Supply Voltage 1	VCC	30	V
Supply Voltage 2	VPOS,VNEG	30	V
Supply Voltage 3	VBIAS	7	V
Standby Voltage	VST	30	V
Power Dissipation 1	Pd1	587.5 <sup>*1</sup>	mW
Power Dissipation 2	Pd2	387.5 <sup>*2</sup>	mW
Operating Temperature Range	Topr	-30~+85	°C
Storage Temperature Range	Tstg	-55~+125	°C
Maximum Junction Temperature	Tjmax	+150	°C

\*1 Reduced by 4.7mW for each increase in Ta of 1°C over 25°C (When mounted on a board 70mm × 70mm × 1.6mm Glass-epoxyPCB)

\*2 Reduced by 3.1mW for each increase in Ta of 1°C over 25°C (With no heat sink)

○ RECOMMENDED OPERATING CONDITIONS

PARAMETER	SYMBOL	LIMIT			UNIT
		MIN	TYP	MAX	
Supply Voltage	VCC	3	5	28	V
Common Mode Input Voltage Range	Vicm	1.8	-	28	V
Differential Input Voltage Range	Vidf	-200	-	200	mV
BIAS Voltage Range	Vbias	1.2	-	Vcc-1.2	V
OUT pin Output Current	Iout	-	-	10	mA

Status of this document

The Japanese version of this document is the official specification.

This translated version is intended only as a reference, to aid in understanding the official version.

If there are any differences between the original and translated versions of this document, the official Japanese language version takes priority.

OELECTRICAL CHARACTERISTICS

(Unless otherwise specified, Ta=25°C ,VCC=VST=5V,VBIAS=2.5V,VPOS-VNEG=ΔVin)

PARAMETER	SYMBOL	LIMIT			UNIT	PARAMETER
		MIN	TYP	MAX		
<b>【General Specifications】</b>						
Supply Voltage	VCC	3	5	30	V	
Quiescent Current	ISC	-	0.0	1.0	μA	VST=0V
Input bias Current	Icc	-	60	100	μA	ΔVin=0V
Voltage Gain (Gv=50)	Gv	49.0	50.0	51.0	mV/mV	Ta=-30~85°C *3
<b>【NEG, POS】</b>						
Input Offset Voltage	Voff	-0.5	0.0	0.5	mV	ΔVin=0V
Common Mode Input Voltage Range	Vicm	1.8	-	30.0	V	
Differential Input Voltage Range	Vidf	-200	-	200	mV	
Input Bias Current	Ib	-	1.2	1.6	μA	ΔVin=0V POS, NEG=2.5V
Input Impedance	Zi	100	-	-	kΩ	
<b>【BIAS】</b>						
BIAS Voltage Range	VBIAS	1.2	-	VCC-1.2	V	
BIAS Sink Current	IBIAS	-	0.0	0.1	uA	
<b>【ST】</b>						
ST Sink Current	IST	-	1.5	10.0	uA	
ST Threshold Voltage	VST	0.3	1.0	2.7	V	
<b>【OUT】</b>						
Output Voltage H	VOUTH	VCC-0.1	VCC	-	V	
Output Voltage L	VOU TL	-	0.0	0.1	V	VCC=3V, VBIAS =1.2V
Output Source Current	Isrc	0.5	1.0	-	mA	VOUT=VCC-0.1V
Output Sink Current	Isink	-	-1.0	-0.5	mA	VOUT=0.1V

©This product is not designed for protection against radioactive rays.

\*3 Design Guarantee

○ PHYSICAL DIMENSIONS

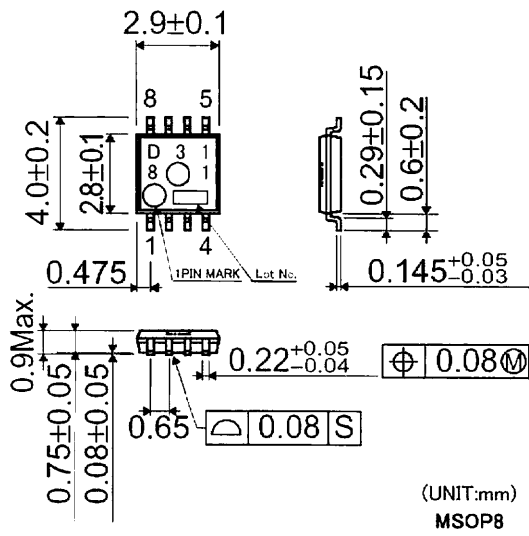

○ BLOCK DIAGRAM

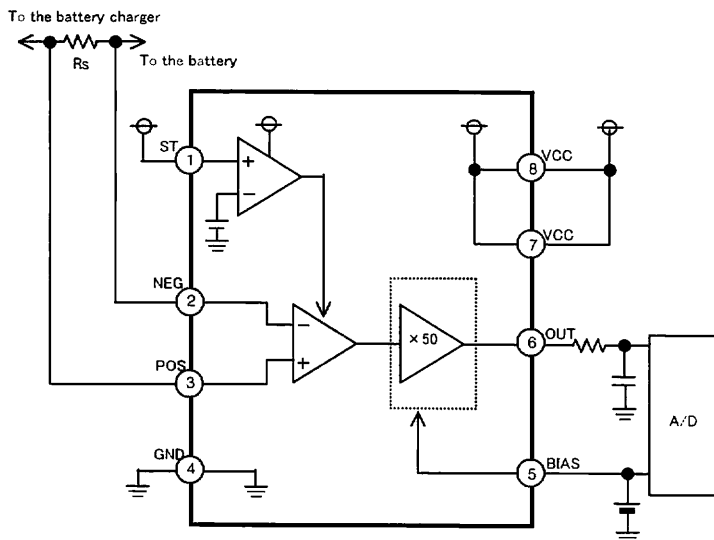

○ Pin number Pin name

Pin number	Pin name
1	ST
2	NEG
3	POS
4	GND
5	BIAS
6	OUT
7	VCC
8	VCC

## ONOTES FOR USE

- (1) Absolute maximum range  
Although the quality of this product is rigorously controlled, and circuit operation is guaranteed within the operation ambient temperature range, the device may be destroyed when applied voltage or operating temperature exceeds its absolute maximum rating. Because the failure mode (such as short mode or open mode) cannot be identified in this instance, it is important to take physical safety measures such as fusing if a specific mode in excess of absolute rating limits is considered for implementation.
- (2) Ground potential  
Make sure the potential for the GND pin is always kept lower than the potentials of all other pins, regardless of the operating mode, including transient conditions.
- (3) Thermal Design  
Provide sufficient margin in the thermal design to account for the allowable power dissipation ( $P_d$ ) expected in actual use.
- (4) Using in the strong electromagnetic field  
Use in strong electromagnetic fields may cause malfunctions.
- (5) ASO  
Be sure that the output transistor for this IC does not exceed the absolute maximum ratings or ASO value.
- (6) GND pattern  
When both a small-signal GND and high current GND are present, single-point grounding (at the set standard point) is recommended, in order to separate the small-signal and high current patterns, and to be sure the voltage change stemming from the wiring resistance and high current does not cause any voltage change in the small-signal GND. In the same way, care must be taken to avoid wiring pattern fluctuations in any connected external component GND.
- (7) When designing the external circuit, provide sufficient margins in the choice of external components by taking worst case of the IC characteristics and external component's characteristics into consideration, including not only during steady state operation, but also during transient operation.
- (8) It is recommended that bypass capacitor be added between VCC and GND as close to each pin as possible.
- (9) Do not connect VCC, GND, and each output with reverse polarity. Please add a protection diode when a large inductance component is connected to the output terminal.

(Example)

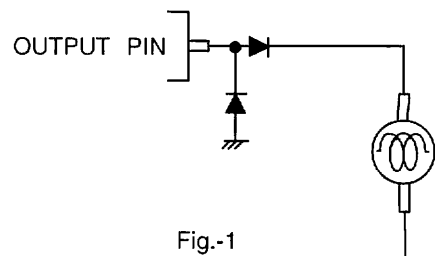

Fig.-1

### Notes

- No technical content pages of this document may be reproduced in any form or transmitted by any means without prior permission of ROHM CO.,LTD.
- The contents described herein are subject to change without notice. The specifications for the product described in this document are for reference only. Upon actual use, therefore, please request that specifications to be separately delivered.
- Application circuit diagrams and circuit constants contained herein are shown as examples of standard use and operation. Please pay careful attention to the peripheral conditions when designing circuits and deciding upon circuit constants in the set.
- Any data, including, but not limited to application circuit diagrams information, described herein are intended only as illustrations of such devices and not as the specifications for such devices. ROHM CO.,LTD. disclaims any warranty that any use of such devices shall be free from infringement of any third party's intellectual property rights or other proprietary rights, and further, assumes no liability of whatsoever nature in the event of any such infringement, or arising from or connected with or related to the use of such devices.
- Upon the sale of any such devices, other than for buyer's right to use such devices itself, resell or otherwise dispose of the same, no express or implied right or license to practice or commercially exploit any intellectual property rights or other proprietary rights owned or controlled by
- ROHM CO., LTD. is granted to any such buyer.
- Products listed in this document are no antiradiation design.

The products listed in this document are designed to be used with ordinary electronic equipment or devices (such as audio visual equipment, office-automation equipment, communications devices, electrical appliances and electronic toys).

Should you intend to use these products with equipment or devices which require an extremely high level of reliability and the malfunction of which would directly endanger human life (such as medical instruments, transportation equipment, aerospace machinery, nuclear-reactor controllers, fuel controllers and other safety devices), please be sure to consult with our sales representative in advance.

#### About Export Control Order in Japan

Products described herein are the objects of controlled goods in Annex 1 (Item 16) of Export Trade Control Order in Japan.

In case of export from Japan, please confirm if it applies to "objective" criteria or an "informed" (by MITI clause) on the basis of "catch all controls for Non-Proliferation of Weapons of Mass Destruction.

Thank you for your accessing to ROHM product informations.  
More detail product informations and catalogs are available,  
please contact your nearest sales office.

Please contact our sales offices for details ;

U.S.A / San Diego	TEL : +1(858)625-3630	FAX : +1(858)625-3670
Atlanta	TEL : +1(770)754-5972	FAX : +1(770)754-0691
Dallas	TEL : +1(972)312-8818	FAX : +1(972)312-0330
Germany / Dusseldorf	TEL : +49(2154)9210	FAX : +49(2154)921400
United Kingdom / London	TEL : +44(1)908-282-666	FAX : +44(1)908-282-528
France / Paris	TEL : +33(0)1 56 97 30 60	FAX : +33(0) 1 56 97 30 80
China / Hong Kong	TEL : +852(2)740-6262	FAX : +852(2)375-8971
Shanghai	TEL : +86(21)6279-2727	FAX : +86(21)6247-2066
Dilian	TEL : +86(411)8230-8549	FAX : +86(411)8230-8537
Beijing	TEL : +86(10)8525-2483	FAX : +86(10)8525-2489
Taiwan / Taipei	TEL : +866(2)2500-6956	FAX : +866(2)2503-2869
Korea / Seoul	TEL : +82(2)8182-700	FAX : +82(2)8182-715
Singapore	TEL : +65-6332-2322	FAX : +65-6332-5662
Malaysia / Kuala Lumpur	TEL : +60(3)7958-8355	FAX : +60(3)7958-8377
Philippines / Manila	TEL : +63(2)807-6872	FAX : +63(2)809-1422
Thailand / Bangkok	TEL : +66(2)254-4890	FAX : +66(2)256-6334

Japan /  
(Internal Sales)

Tokyo	2-1-1, Yaesu, Chuo-ku, Tokyo 104-0082	TEL : +81(3)5203-0321	FAX : +81(3)5203-0300
Yokohama	2-4-8, Shin Yokohama, Kohoku-ku, Yokohama, Kanagawa 222-8575	TEL : +81(45)476-2131	FAX : +81(45)476-2128
Nagoya	Dainagayo Building 9F 3-28-12, Meieki, Nakamura-ku, Nagoya, Aichi 450-0002	TEL : +81(52)581-8521	FAX : +81(52)561-2173
Kyoto	579-32 Higashi Shiokouji-cho, Karasuma Nishi-iru, Shiokoujidori, Shimogyo-ku, Kyoto 600-8216	TEL : +81(75)311-2121	FAX : +81(75)314-6559

(Contact address for overseas customers in Japan)

Yokohama	TEL : +81(45)476-9270	FAX : +81(045)476-9271
----------	-----------------------	------------------------

## Looking for pricing, stock, or lifecycle information?

Click below to explore more details on WIN SOURCE:

- [View BD3181FVM-TR on WIN SOURCE](#)
- [Rohm Semiconductor Information](#)

## Optimize Your Supply Chain with WIN SOURCE Solutions

- ✓ Global Sourcing Solution
- ✓ Obsolete Management
- ✓ Cost Control Management
- ✓ Shortage Management
- ✓ Alternative Solution
- ✓ Excess Inventory Management