



**THE DATASHEET OF
B39881B7719C610**





SAW Components

Data Sheet B7719





SAW Components

B7719

Low-Loss Filter for Mobile Communication

881,5 MHz

Data Sheet



Chip sized SAW package DCS6I

Features

- Low-loss RF filter for mobile telephone GSM850 system, receive path
- Low amplitude ripple
- Usable passband 25 MHz
- Unbalanced to balanced operation
- Impedance transformation from 50 Ω to 200 Ω
- Suitable for GPRS class 1 to 12
- Ceramic package for **Surface Mounted Technology (SMT)**

Terminals

- Ni, gold-plated

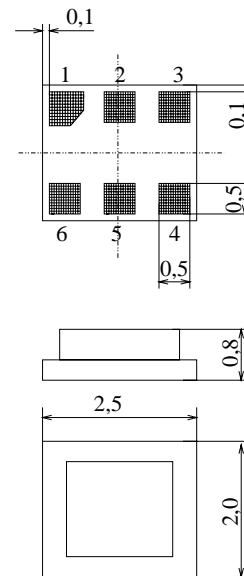

Dimensions in mm, approx. weight 0,014g

Pin configuration

- 2 Unbalanced input
- 4, 6 Balanced output
- 1, 3, 5 To be grounded

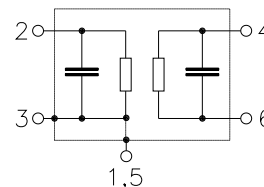

Type	Ordering code	Marking and Package according to	Packing according to
B7719	B39881-B7719-C610	C61157-A7-A76	F61074-V8112-Z000

Electrostatic Sensitive Device (ESD)

Maximum ratings

Operable temperature range	T	- 30 / + 85	°C	peak power of GSM signal, duty cycle 4:8
Storage temperature range	T_{stg}	- 40 / + 85	°C	
DC voltage	V_{DC}	5	V	
ESD	V_{ESD}	50	V	
Input power at GSM850, GSM900, GSM1800 and GSM1900 Tx bands	P_{IN}	15	dBm	



SAW Components

B7719

Low-Loss Filter for Mobile Communication

881,5 MHz

Data Sheet



Characteristics

Operating temperature range: $T = 25 \pm 2 \text{ }^\circ\text{C}$
 Terminating source impedance: $Z_S = 50 \text{ } \Omega$ (unbalanced)
 Terminating load impedance: $Z_L = 200 \text{ } \Omega$ (balanced)

		min.	typ.	max.	
Center frequency	f_C	—	881,5	—	MHz
Maximum insertion attenuation	α_{\max}				
869,0 ... 894,0	MHz	—	2,6	2,8	dB
Amplitude ripple (p-p)	$\Delta\alpha$				
869,0 ... 894,0	MHz	—	1,0	1,2	dB
Unbalanced input VSWR					
869,0 ... 894,0	MHz	—	1,6	2,0	
Balanced output VSWR					
869,0 ... 894,0	MHz	—	1,7	2,0	
Output phase balance ($\phi(S_{31}) - \phi(S_{21}) + 180^\circ$)					
869,0 ... 894,0	MHz	-10	—	+10	degree
Output amplitude balance (S_{31}/S_{21})					
869,0 ... 894,0	MHz	-2,0	—	2,0	dB
Common mode Suppression	S_{sc12}				
0,1 ... 849,0	MHz	20	45	—	
869,0 ... 894,0	MHz	20	25	—	
914,0 ... 6000,0	MHz	20	30	—	
Attenuation	α				
0,0 ... 824,0	MHz	40	60	—	dB
824,0 ... 849,0	MHz	40	57	—	dB
914,0 ... 935,0	MHz	28	33	—	dB
935,0 ... 1135,0	MHz	30	45	—	dB
1135,0 ... 1175,0	MHz	40	65	—	dB
1175,0 ... 2500,0	MHz	35	45	—	dB
2500,0 ... 4000,0	MHz	30	34	—	dB
4000,0 ... 6000,0	MHz	15	25	—	dB



SAW Components

B7719

Low-Loss Filter for Mobile Communication

881,5 MHz

**Data Sheet
Characteristics**



Operating temperature range: $T = -20$ to $+80$ °C
 Terminating source impedance: $Z_S = 50$ Ω (unbalanced)
 Terminating load impedance: $Z_L = 200$ Ω (balanced)

		min.	typ.	max.	
Center frequency	f_C	—	881,5	—	MHz
Maximum insertion attenuation	α_{max}				
869,0 ... 894,0 MHz		—	2,8	3,1	dB
Amplitude ripple (p-p)	$\Delta\alpha$				
869,0 ... 894,0 MHz		—	1,2	1,5	dB
Unbalanced input VSWR					
869,0 ... 894,0 MHz		—	1,6	2,0	
Balanced output VSWR					
869,0 ... 894,0 MHz		—	1,7	2,0	
Output phase balance ($\phi(S_{31})-\phi(S_{21})+180^\circ$)					
869,0 ... 894,0 MHz		-10	—	+10	degree
Output amplitude balance (S_{31}/S_{21})					
869,0 ... 894,0 MHz		-2,0	—	2,0	dB
Common mode Suppression	S_{sc12}				
0,1 ... 849,0 MHz		20	45	—	
869,0 ... 894,0 MHz		20	25	—	
914,0 ... 6000,0 MHz		20	30	—	
Attenuation	α				
0,0 ... 824,0 MHz		40	60	—	dB
824,0 ... 849,0 MHz		38	54	—	dB
914,0 ... 935,0 MHz		26	31	—	dB
935,0 ... 1135,0 MHz		30	45	—	dB
1135,0 ... 1175,0 MHz		40	65	—	dB
1175,0 ... 2500,0 MHz		35	45	—	dB
2500,0 ... 4000,0 MHz		30	34	—	dB
4000,0 ... 6000,0 MHz		15	25	—	dB



SAW Components

B7719

Low-Loss Filter for Mobile Communication

881,5 MHz

Data Sheet



Characteristics

Operating temperature range: $T = -30$ to $+85$ °C
 Terminating source impedance: $Z_S = 50 \Omega$ (unbalanced)
 Terminating load impedance: $Z_L = 200 \Omega$ (balanced)

			min.	typ.	max.	
Center frequency	f_C		—	881,5	—	MHz
Maximum insertion attenuation	α_{max}	869,0 ... 894,0 MHz	—	2,8	3,2	dB
Amplitude ripple (p-p)	$\Delta\alpha$	869,0 ... 894,0 MHz	—	1,2	1,6	dB
Unbalanced input VSWR		869,0 ... 894,0 MHz	—	1,6	2,0	
Balanced output VSWR		869,0 ... 894,0 MHz	—	1,7	2,0	
Output phase balance ($\phi(S_{31}) - \phi(S_{21}) + 180^\circ$)		869,0 ... 894,0 MHz	-10	—	+10	degree
Output amplitude balance (S_{31}/S_{21})		869,0 ... 894,0 MHz	-2,0	—	2,0	dB
Common mode Suppression	S_{sc12}	0,1 ... 849,0 MHz	20	45	—	
		869,0 ... 894,0 MHz	20	25	—	
		914,0 ... 6000,0 MHz	20	30	—	
Attenuation	α	0,0 ... 824,0 MHz	40	60	—	dB
		824,0 ... 849,0 MHz	38	54	—	dB
		914,0 ... 935,0 MHz	26	31	—	dB
		935,0 ... 1135,0 MHz	30	45	—	dB
		1135,0 ... 1175,0 MHz	40	65	—	dB
		1175,0 ... 2500,0 MHz	35	45	—	dB
		2500,0 ... 4000,0 MHz	30	34	—	dB
		4000,0 ... 6000,0 MHz	15	25	—	dB



Transfer function (spec at 25 °C)

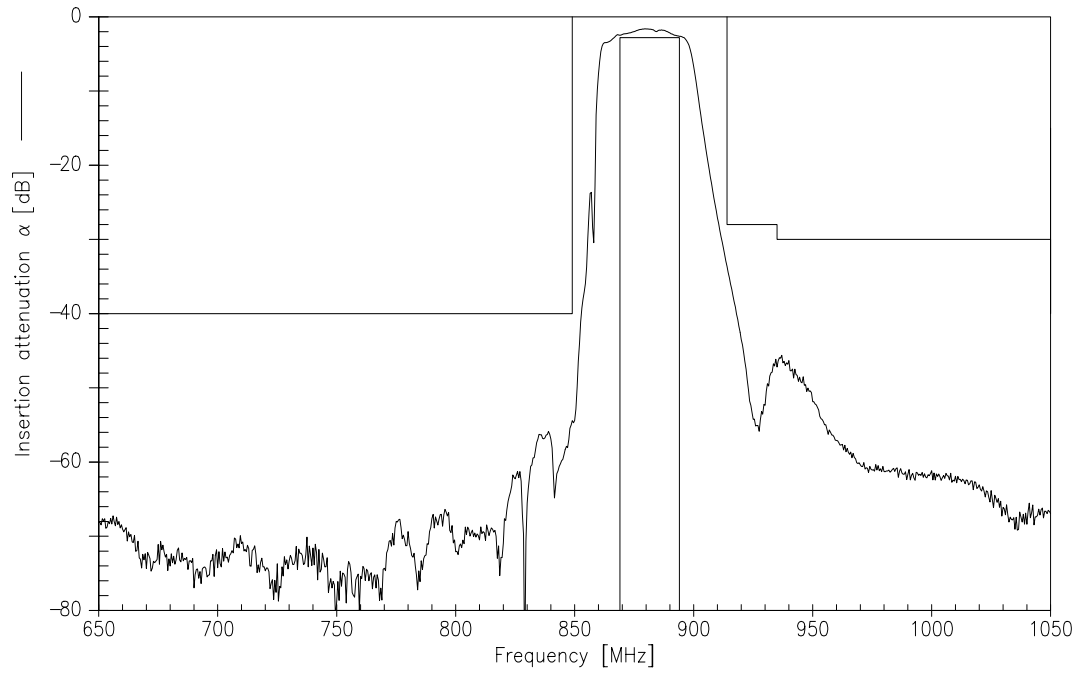

Transfer function (wideband)

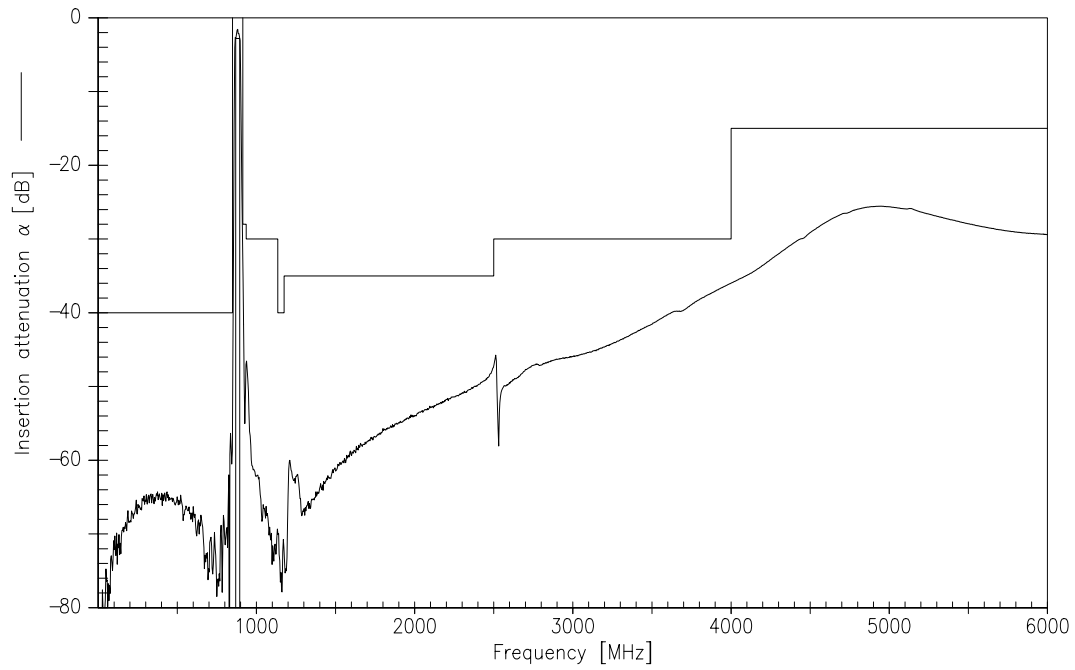



Matching (measurement; S22 is balanced output)

S₁₁

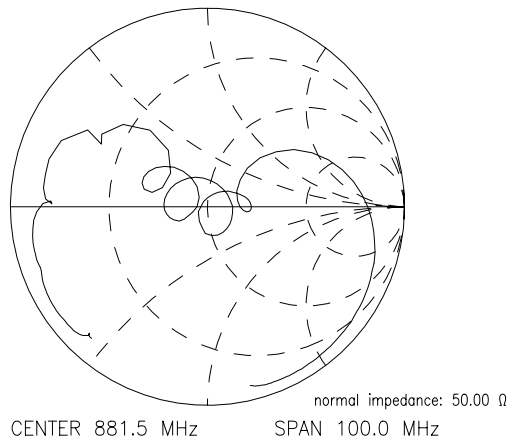
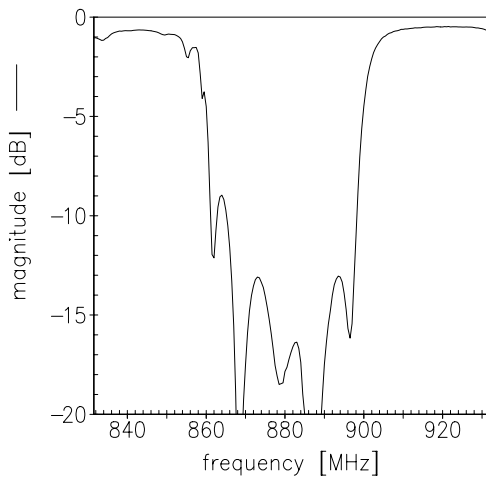

S₂₂

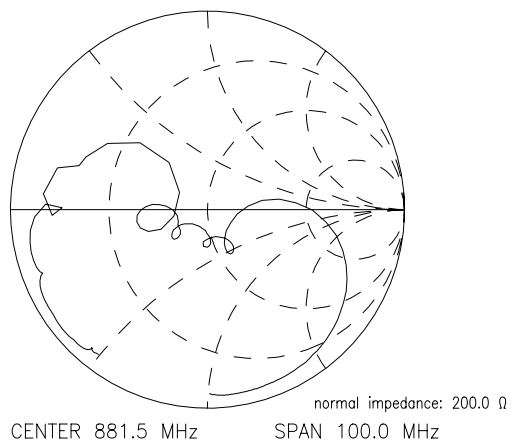
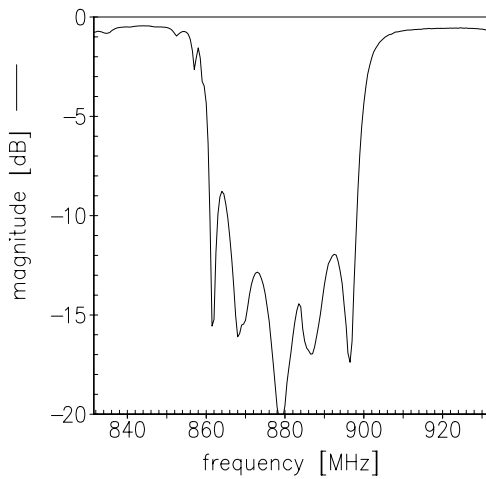



Input amplitude balance ($|S_{31}/S_{21}|$; measurement)

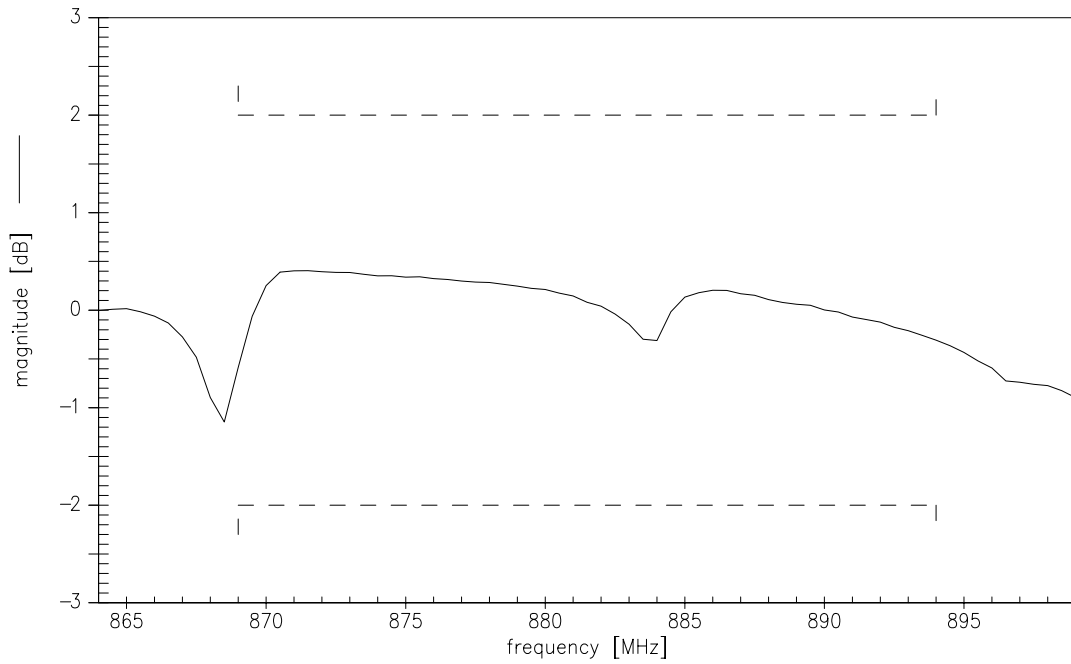

Input phase balance ($\phi(S_{31}) - \phi(S_{21}) + 180^\circ$; measurement)

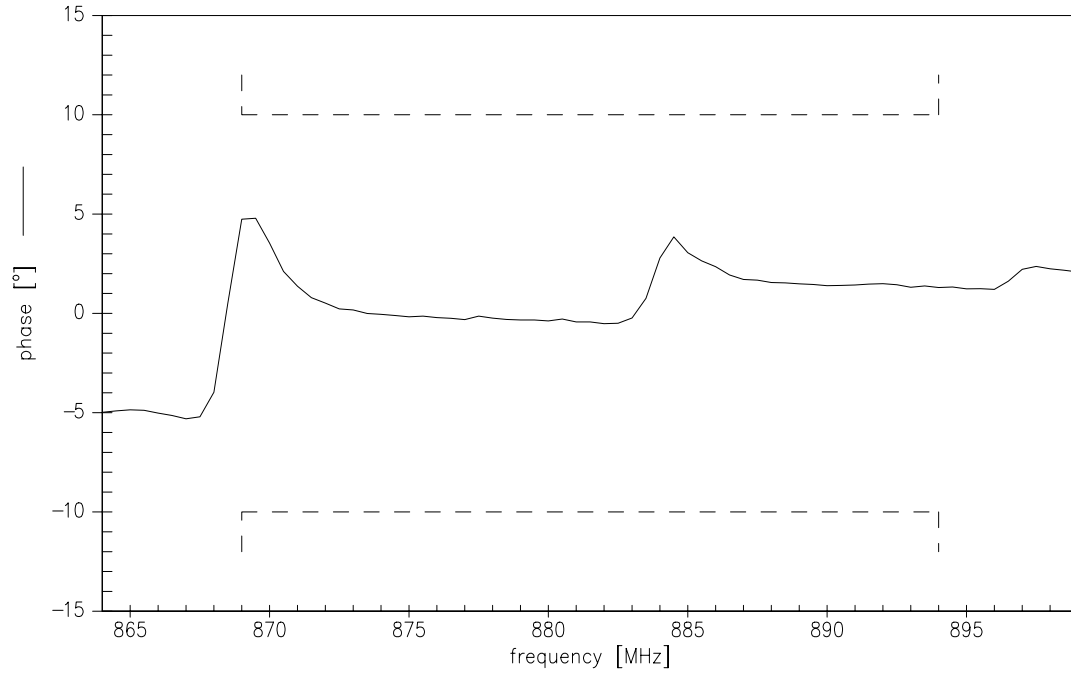



SAW Components

B7719

Low-Loss Filter for Mobile Communication

881,5 MHz

Data Sheet



Published by EPCOS AG

Surface Acoustic Wave Components Division, SAW MC WT

P.O. Box 80 17 09, 81617 Munich, GERMANY

© EPCOS AG 2002. Reproduction, publication and dissemination of this brochure and the information contained therein without EPCOS' prior express consent is prohibited.

Purchase orders are subject to the General Conditions for the Supply of Products and Services of the Electrical and Electronics Industry recommended by the ZVEI (German Electrical and Electronic Manufacturers' Association), unless otherwise agreed.

This brochure replaces the previous edition.

For questions on technology, prices and delivery please contact the Sales Offices of EPCOS AG or the international Representatives.

Due to technical requirements components may contain dangerous substances. For information on the type in question please also contact one of our Sales Offices.

Looking for pricing, stock, or lifecycle information?

Click below to explore more details on WIN SOURCE:

 [View B39881B7719C610 on WIN SOURCE](#)

 [Qualcomm Information](#)

Optimize Your Supply Chain with WIN SOURCE Solutions

-  Global Sourcing Solution
-  Obsolete Management
-  Cost Control Management
-  Shortage Management
-  Alternative Solution
-  Excess Inventory Management