



**THE DATASHEET OF
ATF15XXDK3-SAA100**



Introduction

The Atmel® ATF15xx-DK3 Complex Programmable Logic Device (CPLD) Development/Programmer Kit is a complete development system and an In-System Programming (ISP) programmer for the Atmel ATF15xx Family of industry standard pin compatible CPLDs with Logic Doubling® features. This kit provides designers a very quick and easy way to develop prototypes and evaluate new designs with an ATF15xx ISP CPLD. The ATF15xx Family of ISP CPLDs includes the Atmel ATF15xxAS, ATF15xxASL, ATF15xxASV, and ATF15xxASVL CPLDs. With the availability of the different socket adapter boards to support most of the package types⁽¹⁾ offered in the ATF15xx Family of ISP CPLDs, this kit can be used as an ISP programmer to program the ATF15xx ISP CPLDs in most of the available package types⁽¹⁾ through the industry standard JTAG interface (IEEE 1149.1).

Kit Contents

- Atmel CPLD Development/Programmer Board (P/N: ATF15xx-DK3)
- Atmel 44-pin TQFP Socket Adapter Board (P/N: ATF15xx-DK3-SAA44)⁽²⁾
- Atmel ATF15xx LPT-based JTAG ISP Download Cable (P/N: ATDH1150VPC)
- Two Atmel 44-pin TQFP Sample Devices

Device Support

The ATF15xx-DK3 CPLD Development/Programmer Kit supports the following devices in all currently available Atmel speed grades and packages (except the 100-PQFP):

- ATF1502AS/ASL
- ATF1504AS/ASL
- ATF1508ASV/ASVL
- ATF1502ASV
- ATF1504ASV/ASVL
- ATF1508AS/ASL



1. The socket adapter board is not offered for the 100-pin PQFP.
2. Only the 44-pin TQFP Socket Adapter Board is included in this kit. Other socket adapter boards are sold separately. See Section, “[Hardware Description](#)” for more information on socket adapter board ordering codes.

Table of Contents

Kit Features	3
CPLD Development/Programmer Board	3
Logic Doubling CPLDs	3
ATF15xx ISP Download Cable	3
PLD Development Software	3
System Requirements	3
Ordering Information	4
Hardware Description	4
CPLD Development/Programmer Board	4
7-segment Displays with Selectable Jumpers	5
LEDs with Selectable Jumpers	7
Push-button Switches with Selectable Jumpers for I/O Pins	8
Push-button Switches with Selectable Jumpers for GCLR and OE1 Pins	9
2MHz Oscillator and Clock Selection Jumper	10
V _{CC} IO and V _{CC} INT Voltage Selection Jumpers and LEDs	11
I _{CC} IO and I _{CC} INT Jumpers	11
Voltage Regulators	11
Power Supply Switch and Power LED	11
Power Supply Jack and Power Supply Header	11
JTAG ISP Connector and TDO Selection Jumper	12
Socket Adapter Board	14
Atmel ATF15xx ISP Download Cable	14
Schematic Diagrams	16
References and Support	21
Atmel ProChip Designer Software	21
Atmel WinCUPL Software	21
Atmel ATMISP Software	21
Atmel POF2JED Conversion Software	21
Technical Support	22
Revision History	22

Kit Features

CPLD Development/Programmer Board

- 10-pin JTAG-ISP Port
- Regulated Power Supply Circuits for 9VDC Power Source
- Selectable 5V, 3.3V, 2.5V, or 1.8V I/O Voltage Supply
- Selectable 1.8V, 3.3V, or 5.0V Core Voltage Supply
- 44-pin TQFP Socket Adapter Board
- Headers for I/O Pins of the ATF15xx Device
- 2MHz Crystal Oscillator
- Four 7-segment LED Displays
- Eight Individual LEDs
- Eight Push-button Switches
- Global Clear and Output Enable Push-button Switches
- Current Measurement Jumpers

Logic Doubling CPLDs

- ATF15xx ISP CPLD with Logic Doubling Architecture

ATF15xx ISP Download Cable

- 5V, 3.3V, 2.5V, or 1.8V ISP Download Cable for PC Parallel Printer (LPT) Port

PLD Development Software

The Atmel PLD development software tools are available online for PLD designer's use of the ATF15xx ISP CPLDs. Please reference the Overview document, "PLD Design Software Overview" available at:

<http://www.atmel.com/images/atmel-3629-pld-design-software-overview.pdf>

System Requirements

The minimum hardware and software required to program an ATF15xx ISP CPLD device which is designed using the Atmel ProChip Designer Software on the CPLD Development/Programmer Board through the Atmel ATMISP v6.x (ATF15xx CPLD ISP Software) are:

- x86 Microprocessor-based Computer
- Windows XP®, Windows® 98, Windows NT® 4.0, or Windows 2000
- 128-MByte RAM
- 500-MByte Free Hard Disk Space
- Windows-supported Mouse
- Available Parallel Printer (LPT) Port
- 9VDC Power Supply with 500mA of Supply Current
- SVGA Monitor (800 x 600 Resolution)

Ordering Information

Atmel Part Number	Description
ATF15xx-DK3	CPLD Development/Programmer Kit (includes the ATF15xxDK3-SAA44*)
ATF15xxDK3-SAA100	100-pin TQFP Socket Adapter Board for DK3 Board
ATF15xxDK3-SAJ44	44-pin PLCC Socket Adapter Board for DK3 Board
ATF15xxDK3-SAJ84	84-pin PLCC Socket Adapter Board for DK3 Board
ATF15xxDK3-SAA44*	44-pin TQFP Socket Adapter Board for DK3 Board

Hardware Description

CPLD Development/Programmer Board

The CPLD Development/Programmer and Socket Adapter Boards shown in the below figure contain features that are useful for developing, prototyping, or evaluating ATF15xx CPLD designs. Features that make this a very versatile starter/development kit and an ISP programmer for the ATF15xx family of JTAG-ISP CPLDs include:

- Push-button Switches
- LEDs
- 7-segment Displays
- 2MHz Crystal Oscillator
- 5V, 3.3V, 2.5V, or 1.8V V_{CCIO} Selector
- 1.8V, 3.3V, or 5.0V V_{CCINT} Selector
- JTAG ISP Port
- Socket Adapters

Figure 1. CPLD Development/Programmer Kit with 44-pin TQFP Socket Adapter Board

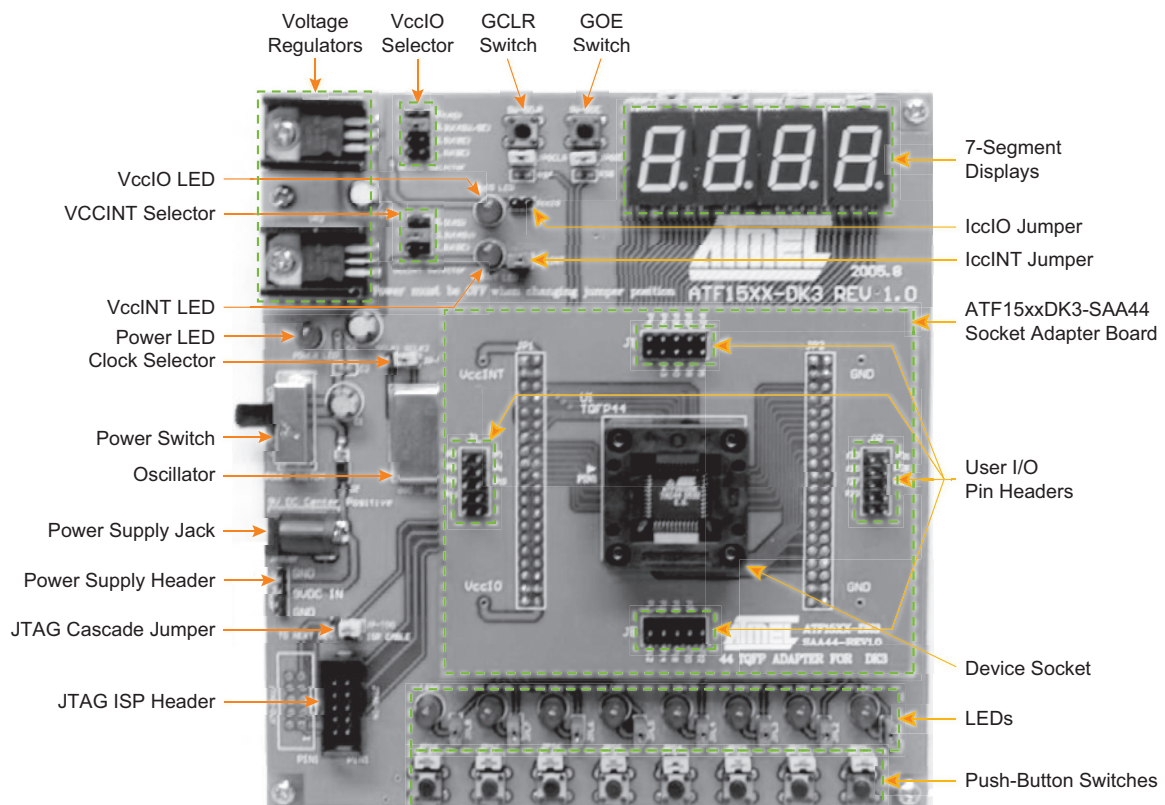

7-segment Displays with Selectable Jumpers

The CPLD Development/Programmer Board contains four 7-segment displays which allow the observation of the ATF15xx CPLD outputs. These four displays are labeled as DSP1, DSP2, DSP3, and DSP4. The 7-segment displays have common anode LEDs with the common anode lines connected to the V_{CCIO} (I/O supply voltage for the CPLD) through a series of resistors with selectable jumpers labeled as JPDSP1, JPDSP2, JPDSP3, and JPDSP4. These jumpers can be removed to disable the displays by unconnecting the V_{CCIO} to the displays. Individual cathode lines are connected to the I/O pins of the ATF15xx CPLD on the CPLD Development/Programmer Kit. To turn on a particular segment, including the DOT of a display, the corresponding ATF15xx I/O pin connected to this LED segment must be in a logic low state with the corresponding selectable jumper set; therefore, the outputs of the ATF15xx device will require configuration for active-low outputs in the design file. The displays work best at 2.5V V_{CCIO} or higher.

Each segment of each display is hard-wired to one specific I/O pin of the ATF15xx device. For the higher pin count devices (100-pin and larger), all seven segments and the DOT segments of the four displays are connected to the I/O pins; however, for the lower pin count devices, only a subset of the displays, first and fourth displays, are connected to the ATF15xx device's I/O pins. Tables 1 and 2 show the 7-segment display package connections to the ATF15xx device. The circuit schematic of the displays and jumpers is shown in the figure below.

Figure 2. Circuit Diagram of 7-segment Display and Jumpers

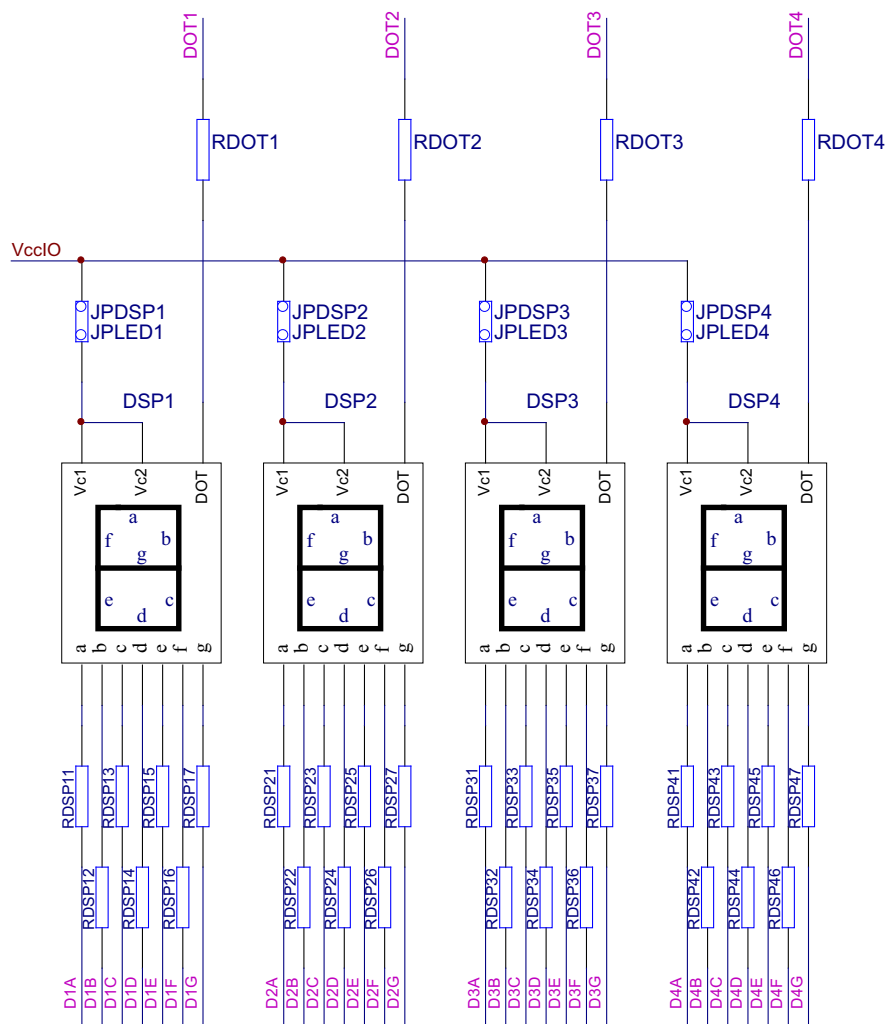

Table 1. ATF15xx 44-pin Connections to 7-segment Displays

44-pin TQFP				44-pin PLCC			
DSP/Segment	PLD Pin	DSP/Segment	PLD Pin	DSP/Segment	PLD Pin	DSP/Segment	PLD Pin
1/A	27	3/A	NC	1/A	33	3/A	NC
1/B	33	3/B	NC	1/B	39	3/B	NC
1/C	30	3/C	NC	1/C	36	3/C	NC
1/D	21	3/D	NC	1/D	27	3/D	NC
1/E	18	3/E	NC	1/E	24	3/E	NC
1/F	23	3/F	NC	1/F	29	3/F	NC
1/G	20	3/G	NC	1/G	26	3/G	NC
1/DOT	31	3/DOT	NC	1/DOT	37	3/DOT	NC
2/A	NC	4/A	3	2/A	NC	4/A	9
2/B	NC	4/B	10	2/B	NC	4/B	16
2/C	NC	4/C	6	2/C	NC	4/C	12
2/D	NC	4/D	43	2/D	NC	4/D	5
2/E	NC	4/E	35	2/E	NC	4/E	41
2/F	NC	4/F	42	2/F	NC	4/F	4
2/G	NC	4/G	34	2/G	NC	4/G	40
2/DOT	NC	4/DOT	11	2/DOT	NC	4/DOT	17

Table 2. ATF15xx 84-pin and 100-pin Connections to 7-segment Displays

84-pin PLCC				100-pin TQFP			
DSP/Segment	PLD Pin	DSP/Segment	PLD Pin	DSP/Segment	PLD Pin	DSP/Segment	PLD Pin
1/A	68	3/A	22	1/A	67	3/A	13
1/B	74	3/B	28	1/B	71	3/B	19
1/C	70	3/C	25	1/C	69	3/C	16
1/D	63	3/D	21	1/D	61	3/D	8
1/E	58	3/E	16	1/E	57	3/E	83
1/F	65	3/F	17	1/F	64	3/F	6
1/G	61	3/G	12	1/G	60	3/G	92
1/DOT	73	3/DOT	29	1/DOT	75	3/DOT	20
2/A	52	4/A	5	2/A	52	4/A	100
2/B	57	4/B	10	2/B	54	4/B	94
2/C	55	4/C	8	2/C	47	4/C	97
2/D	48	4/D	79	2/D	41	4/D	81
2/E	41	4/E	76	2/E	46	4/E	76
2/F	50	4/F	77	2/F	40	4/F	80
2/G	45	4/G	75	2/G	45	4/G	79
2/DOT	50	4/DOT	11	2/DOT	56	4/DOT	93

LEDs with Selectable Jumpers

The CPLD Development/Programmer Board has eight individual LEDs, which allow designers to display the output signals from the user I/Os of the ATF15xx devices. These eight LEDs are labeled LED1 to LED8 on the CPLD Development/Programmer Board. The cathode of each LED is connected to Ground (GND) through a series resistor, while the anode of each LED is connected to a user I/O pin of the CPLD through the JPL1/2/3/4/5/6/7/8 selectable jumper. These jumpers can be removed to disable the LEDs by unconnecting the anodes of the LEDs to the I/O pins of the CPLD. The figure below illustrates the circuit diagram of the LEDs with the selection jumpers.

To turn on a particular LED, the corresponding ATF15xx I/O pin connected to the LED must be in a logic high state with the corresponding jumper set; therefore, the outputs of the ATF15xx device will need to be configured as active high outputs. The LEDs work best at 2.5V V_{CCIO} or higher.

The lower pin count devices (44-pin) only have four I/Os connected to LED1/2/3/4. For the higher pin-count devices (100-pin and larger), all eight LEDs are connected to the I/Os of the device. [Table 3](#) shows the different package connections of the CPLD I/Os to the LEDs.

Figure 3. Circuit Diagram of the LEDs and Jumpers

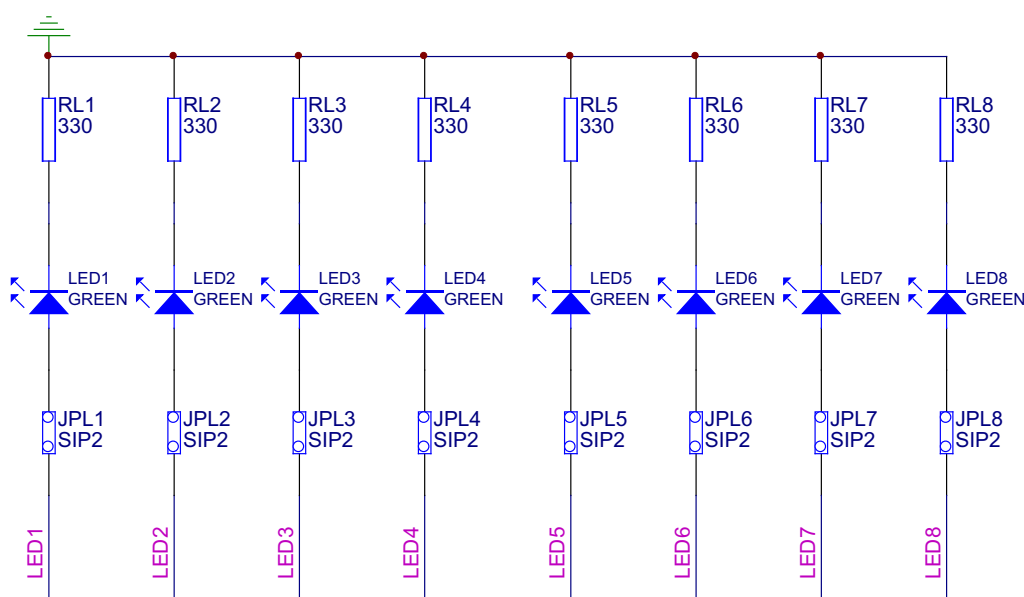

Table 3. ATF15xx Connections to LEDs

44-pin TQFP		44-pin PLCC		84-pin PLCC		100-pin TQFP	
LED	PLD Pin	LED	PLD Pin	LED	PLD Pin	LED	PLD Pin
LED1	28	LED1	34	LED1	69	LED1	68
LED2	25	LED2	31	LED2	67	LED2	65
LED3	22	LED3	28	LED3	64	LED3	63
LED4	19	LED4	25	LED4	60	LED4	58
				LED5	27	LED5	17
				LED6	24	LED6	14
				LED7	18	LED7	10
				LED8	15	LED8	9

Push-button Switches with Selectable Jumpers for I/O Pins

The CPLD Development/Programmer Board contains eight push-button switches, which are connected to the I/O pins of the CPLD. The switches send input logic signals to the user I/O pins of the ATF15xx device. These switches are labeled SW1 to SW8 on the CPLD Development/Programmer Board. One end of each input push-button switch is connected to V_{CCIO} , while the other end of each push-button switch is connected to a pull-down resistor and then connected to the specific I/O pin of the CPLD through the JPS1/2/3/4/5/6/7/8 selectable jumper.

If any one of these switches is pressed and the corresponding jumper is set, the specific I/O pin of the device will be driven to a logic high state by the output of switch circuit. Since each push-button switch is also connected to a pull-down resistor, the input will have a logic low state if the switch is not pressed with the corresponding jumper set. If the push-button jumper is not set, the corresponding pin will be treated as an unconnected pin. Figure 4 is a circuit diagram of the push-button switch and selectable jumper. Table 4 shows the connections of these eight push-button switches to the CPLD I/O pins in the different package types.

Figure 4. Circuit Diagram of the Push-button Switches and Jumpers for the I/O Pins

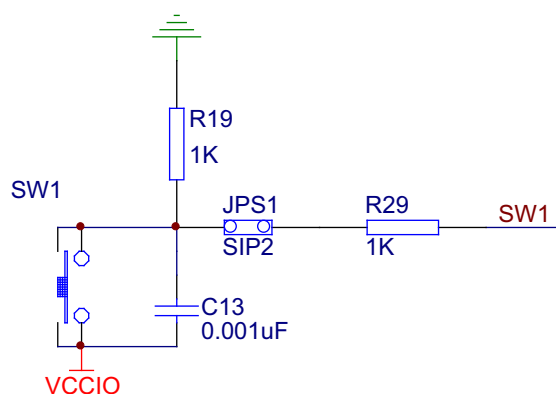

Table 4. ATF15xx Connections to the I/O Pin Switches

44-pin TQFP		44-pin PLCC		84-pin PLCC		100-pin TQFP	
Push Button	PLD Pin	Push Button	PLD Pin	Push Button	PLD Pin	Push Button	PLD Pin
SW1	15	SW1	21	SW1	54	SW1	48
SW2	14	SW2	20	SW2	51	SW2	36
SW3	13	SW3	19	SW3	49	SW3	44
SW4	12	SW4	18	SW4	44	SW4	37
SW5	8	SW5	14	SW5	9	SW5	96
SW6	5	SW6	11	SW6	6	SW6	98
SW7	2	SW7	8	SW7	4	SW7	84
SW8	44	SW8	6	SW8	80	SW8	99

Push-button Switches with Selectable Jumpers for GCLR and OE1 Pins

The CPLD Development/Programmer Board contains two push-button switches for the Global Clear (GCLR) and Output Enable (OE1) pins of the CPLD. The switches control the logic states of the OE1 and GCLR inputs of the ATF15xx devices. These switches are labeled SW-GCLR and SW-GOE1 on the board. One end of the SW-GCLR input push-button switch is connected to GND. The other end of the push-button switch is connected to a pull-up resistor to V_{CCIO} , and then connected to the GCLR dedicated input pin of the ATF15xx device. It is intended to be used as an active-low reset signal to reset the registers in the ATF15xx device with the JPGCLR selectable jumper set. Similarly, one end of the SW-GOE1 input push-button switch is connected to GND. The other end of the push-button switch is connected to a pull-up resistor to V_{CCIO} , and then connected to the OE1 dedicated input pin of the ATF15xx device. It is intended to be used as an active-low output enable signal to control the enabling/disabling of the tri-state output buffers in the ATF15xx with the JPGOE selectable jumper set. [Figure 5](#) is the circuit diagram of the push-button switches and the jumpers for the GCLR and OE1 pins.

If any of these push-button switches is pressed and the corresponding jumper is set, the specific I/O of the CPLD will be driven to a logic low state. Since each push-button is also connected to a pull-up resistor, the corresponding CPLD input will have a logic high state if the push-button switch is not pressed with the corresponding selectable jumper set. If the selectable jumper is not set, the corresponding dedicated input pin of the CPLD can be considered a No Connect (NC) pin. [Table 5](#) shows the pin numbers of the GCLR and OE1 dedicated input pins of the ATF15xx devices in all available package types.

Figure 5. Circuit Diagram of Push-button Switches and Selectable Jumpers for GCLR and OE1

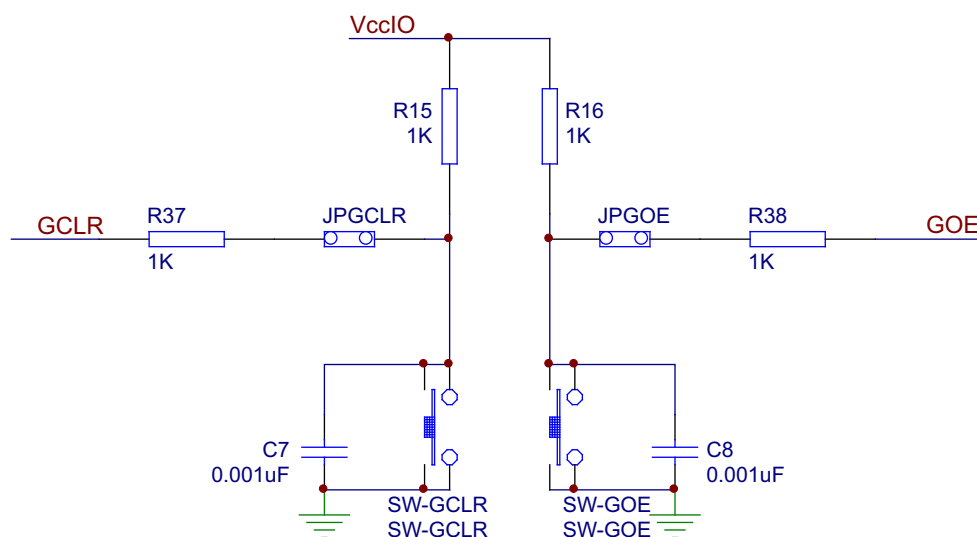

Table 5. Pin Numbers of GCLR and OE1

	44-pin TQFP	44-pin PLCC	84-pin PLCC	100-pin TQFP
GCLR	39	1	1	89
OE1	38	44	84	88

2MHz Oscillator and Clock Selection Jumper

The Clock Selection Jumper labeled JP-GCLK on the CPLD Development/Programmer Board is a two-position jumper that allows the users to select which GCLK dedicated input pin (either GCLK1 or GCLK2) of the ATF15xx device should be connected to the output of the 2MHz oscillator. In addition, the jumper can be removed to allow an external clock source to be connected to GCLK1 and/or GCLK2 of the ATF15xx device. Figure 6 is an illustration of the circuit diagram of the oscillator and selection jumper. Table 6 shows the pin numbers for the GCLK1 and GCLK2 dedicated input pins of the ATF15xx device in all the different available package types.



If GCLK1 jumper is set, the jumper will be located toward the side of the board. On the other hand, if GCLK2 jumper is set, the jumper will be located toward the middle of the board.

Figure 6. Circuit Diagram of Oscillator and Clock Selection Jumper

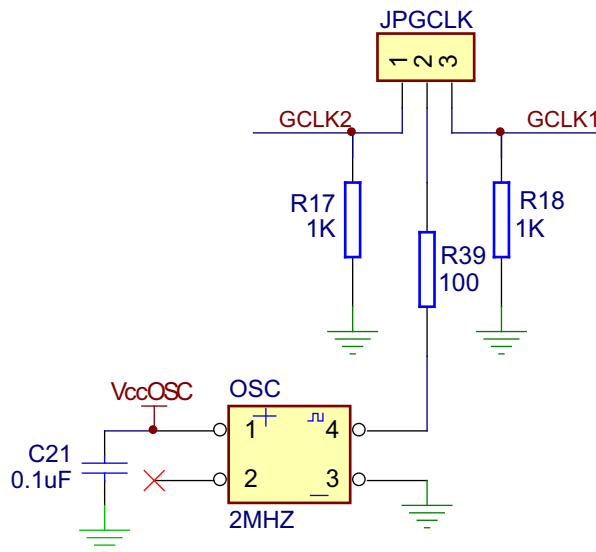

Table 6. Pin Numbers of GCLK1 and GCLK2

	44-pin TQFP	44-pin PLCC	84-pin PLCC	100-pin TQFP
GCLK1	37	43	83	87
GCLK2	40	2	2	90

V_{CC}IO and V_{CC}INT Voltage Selection Jumpers and LEDs

The V_{CC}IO and V_{CC}INT Voltage Selection Jumpers, labeled VCCIO Selector and VCCINT Selector respectively on ATF15xx-DK3 Development/Programming Kit, allow the selection of the I/O supply voltage level (V_{CC}IO) and core supply voltage level (V_{CC}INT) that are used for the target CPLD on the kit. Once these jumpers are set correctly, the LEDs (labeled VCCINT LED and VCCIO LED) will turn on; however, at lower supply voltage levels (i.e. 2.5V or lower), the LEDs might be very dim.

- For ATF15xxAS/ASL (5.0V) CPLDs, both the VCCIO Selector and VCCINT Selector jumpers *must be* set to 5.0V.
- For ATF15xxASV/ASVL (3.3V) CPLDs, both the VCCIO Selector and VCCINT Selector Jumpers *must be* set to 3.3V only.



The power of the CPLD Development/Programmer Kit *must be* turned OFF when changing the position of the V_{CC}IO or V_{CC}INT Voltage Selection Jumper (VCCIO Selector or VCCINT Selector).

I_{CC}IO and I_{CC}INT Jumpers

The I_{CC}IO and I_{CC}INT jumpers can be removed and used as I_{CC} measurement points. When the jumpers are removed, current meters can be connected to the posts to measure the current consumption of the target CPLD. When users are not using these jumpers to measure the current, these jumpers *must be* set in order for the kit and CPLD to operate.

Voltage Regulators

Two voltage regulators, labeled VR1 and VR2, are used to independently generate and regulate the V_{CC}INT and V_{CC}IO voltages from the 9VDC power supply. For details, please see the ATF15xx-DK3 kit schematic, [Figure 12](#).

Power Supply Switch and Power LED

The Power Supply Switch, labeled POWER SWITCH, can be switched to the **on** or **off** position, which is used to turn on or off the power of the ATF15xx-DK3 board respectively. It allows the 9VDC voltage at the Power Supply Jack to pass to the voltage regulators when it is in the **on** position. When the Power Supply Switch is turned **on**, the Power LED (labeled POWER LED) will light up to indicate that the ATF15xx-DK3 Kit is supplied with power.

Power Supply Jack and Power Supply Header

The ATF15xx-DK3 board contains two different types of power supply connectors labeled JPower and JP Power. Either one of these power supply connectors can be used to connect a 9VDC power source to the kit. The first power connector labeled JPower, is a barrel power jack with a 2.1mm diameter post, and it mates to a 2.1mm (inner diameter) x 5.5mm (outer diameter) female plug. The second power supply header labeled JP Power, is a 4-pin male 0.100" header with 0.025" square posts. The availability of these two types of power connectors allows the users to choose the type of power supply equipment to use for ATF15xx-DK3 Development/Programmer Kit.



Only one of these two power supply connectors should be powered with a 9VDC source but not both at the same time.

JTAG ISP Connector and TDO Selection Jumper

The JTAG ISP Connector labeled JTAG-IN, is used to connect the ATF15xx JTAG port pins (TCK, TDI, TMS, and TDO) through the ISP download cable to the parallel printer (LPT) port of a PC for JTAG ISP programming of the ATF15xx device. Polarized connectors are used on the ATF15xx-DK3 and ISP Download Cable to minimize connection problems. The PIN1 label at the bottom of the JTAG ISP connector indicates the pin 1 position of the 10-pin header and further reduces the chance of connecting the ISP Download Cable incorrectly.

To the left of the JTAG-IN connector, there are two columns of vias, and they are labeled JTAG-OUT. They are intended to allow the users to create a JTAG daisy chain to perform JTAG operations to multiple devices. Users will need to solder the same type of connector as the one used for JTAG-IN into the JTAG-OUT position in order to utilize this available feature.

To create a JTAG daisy chain using multiple ATF15xx-DK3 boards, the TDO Selection Jumper, labeled JP-TDO, must be set to the appropriate position. For all the devices in the daisy chain except the last device, this jumper must be set to the **TO NEXT DEVICE** position. For the last device in the chain, this jumper must be set to the **TO ISP CABLE** position. When this jumper is in the **TO NEXT DEVICE** position, the TDO of that particular JTAG device will be connected to the TDI of the next JTAG device in the chain. When this jumper is in the **TO ISP CABLE** position, the TDO of that device will be connected to the TDO of the JTAG 10-pin connector, which will allow the TDO signal of the that device in the chain to be transmitted back to the host PC with the ISP software. The figure below is a circuit diagram of the JTAG connectors and the JP-TDO jumper. The table below lists the pin numbers of the four JTAG pins for the ATF15xx device in all the available packages.

For a single device setup, the position of the JP-TDO jumper must be set to **TO ISP CABLE**.

Figure 7. Circuit Diagram of the JTAG ISP Connectors and TDO Jumper

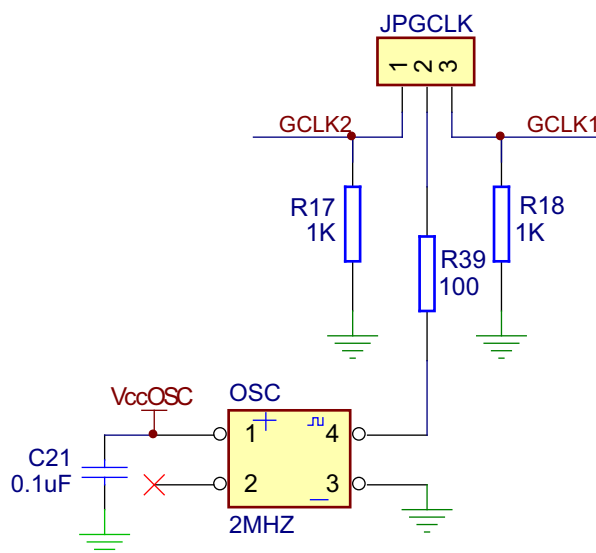

Table 7. Pin Numbers of JTAG Port Signals

	44-pin TQFP	44-pin PLCC	84-pin PLCC	100-pin TQFP
TDI	1	7	14	4
TDO	32	38	71	73
TMS	7	13	23	15
TCK	26	32	62	62

The ISP algorithm is controlled by the ATMISP software, which is running on the PC. The four JTAG signals are generated by the LPT port, and they are buffered by the ISP download cable before going into the ATF15xx device on the CPLD Development/Programmer board. The 10-pin JTAG Port Header pinout on the CPLD Development/Programmer board is shown in [Figure 8](#), and the dimensions of this 10-pin male JTAG header are shown in [Figure 9](#).

Figure 8. 10-pin JTAG Port Header Pinout

10-Pin JTAG Port Header
(Top View)

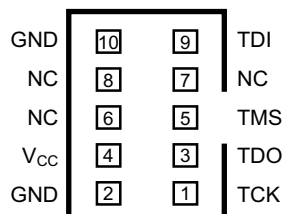
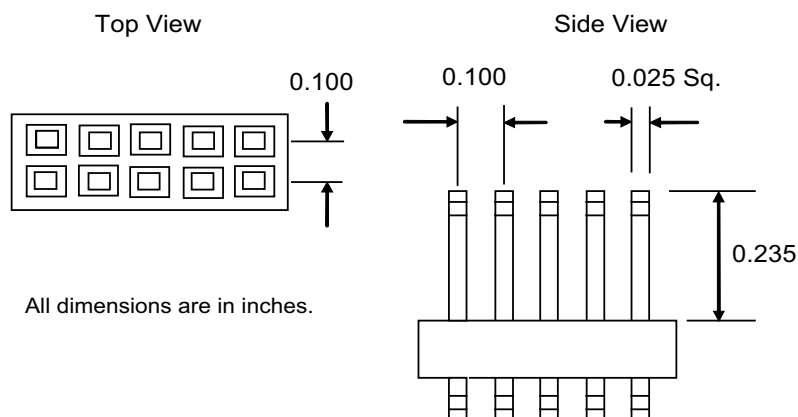

Figure 9. 10-pin Male Header Dimensions



The 10-pin JTAG Port Header pinout is compatible with the ATDH1150PC/VPC LPT port based cable and ATDH1150USB USB port based cable, as well as the Altera ByteBlaster/MV/II LPT port based cables. In addition, the ATMISP v6.7 software allows the use of either the Atmel ATDH1150PC/VPC/USB cable or the ByteBlaster/MV/II cable to implement ISP.



ATMISP v7.0 only supports the ATDH1150USB cable.

Socket Adapter Board

The ATF15xx-DK3 CPLD Development/Programmer Socket Adapter Boards (ATF15xx-DK3-XXXXX) are circuit boards that interface with the ATF15xx-DK3 CPLD Development/Programmer Board. They are used in conjunction with the ATF15xx-DK3 CPLD Development/Programmer Board to evaluate or program ATF15xx ISP CPLD devices in different package types. There are four Socket Adapter Boards available for the ATF15xx-DK3 covering the 44-TQFP, 44-PLCC, 84-PLCC, and 100-TQFP package types in the ATF15xx family of CPLDs.

Each socket adapter board contains a socket for the ATF15xx device and has male headers on the bottom side, labeled JP1 and JP2. The headers on the bottom side mate with the female headers on the ATF15xx-DK3 board, labeled JP4 and JP3. The four 7-segment displays, push-button switches, JTAG port signals, oscillator, V_{CCINT} , V_{CCIO} , and GND on the CPLD Development/Programmer Board are connected to the ATF15xx device on the Socket Adapter Board through these two sets of connectors.

On the top of the 44-TQFP socket adapter, there are four 10-pin connectors with the same dimensions as the JTAG ISP connector. The pins of these four connectors are connected to the input and I/O pins (except the four JTAG pins) of the target CPLD device. They can be used to connect to an oscilloscope or logic analyzer to capture the activities of the input and I/O pins of the CPLD. They also can be used to connect the input and I/O pins of the CPLD to other external boards or devices for system level evaluation or testing.

Atmel ATF15xx ISP Download Cable

The ATF15xx ISP Download Cable (P/N: ATDH1150VPC) connects the LPT port of the PC to the 10-pin JTAG header on the CPLD Development/Programmer Board or a custom circuit board. This is shown in [Figure 10](#). This ISP cable acts as a buffer to buffer the JTAG signals between the PC's LPT port and the ATF15xx on the circuit board. The Power-On LED on the back of the 25-pin male connector housing indicates that the cable is connected properly.



Be sure this LED is turned on before using the Atmel CPLD ISP Software (ATMISP).

This ISP cable consists of a 25-pin (DB25) male connector, which is connected to the LPT port of a PC. The 10-pin female plug connects to the 10-pin male JTAG header on the ISP circuit board. The red color stripe on the ribbon cable indicates the orientation of pin 1 of the female plug. The 10-pin male JTAG header on the CPLD Development/Programmer Board is polarized to prevent users from inserting the female plug in the wrong orientation.

The CPLD Development/Programmer kits includes the ATF15xx ISP Download Cable (ATDH1150VPC); however, other supported ISP cables can also be used. The ATDH1150VPC, ATDH1150USB, ByteBlasterMV, and ByteBlasterII cables can be used for the ATF15xx/ASL (5V) and ATF15xxASV/ASVL (3.3V) devices, while the older ATDH1150PC and the ByteBlaster cables can be used for the ATF15xxAS/ASL (5V) only.

Figure 10. ATF15xx ISP Download Cable Connection to ISP Hardware Board/Circuit Board

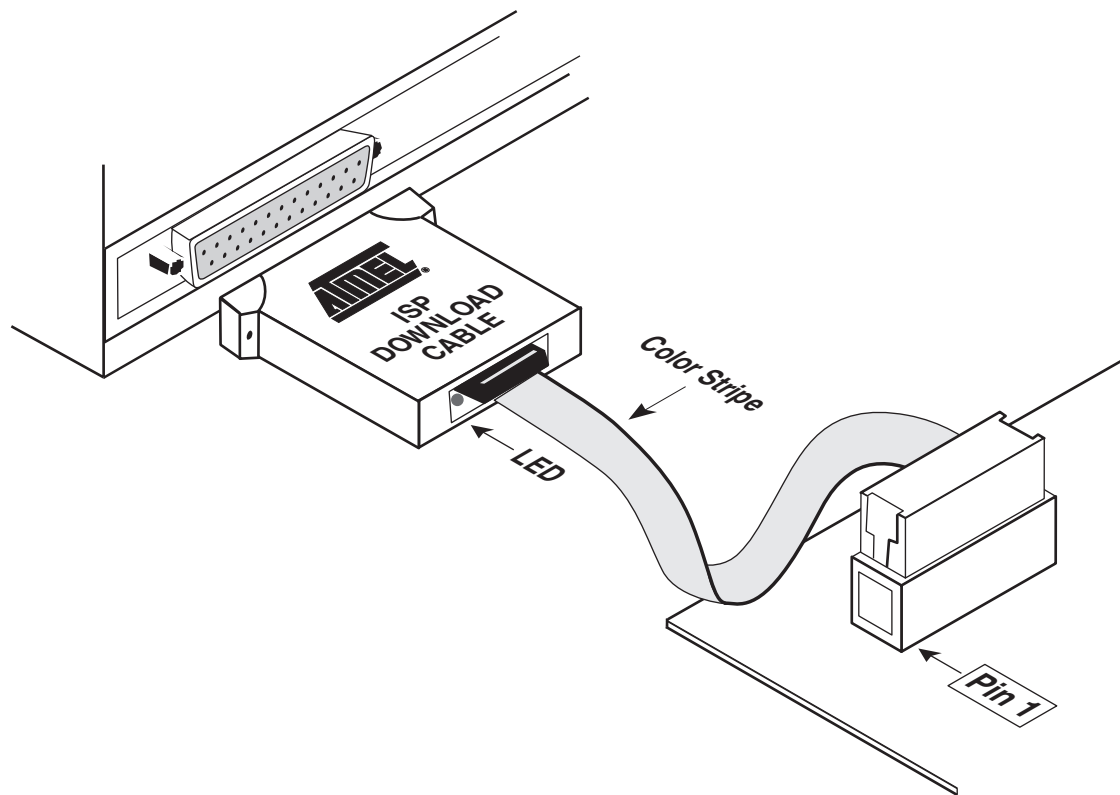
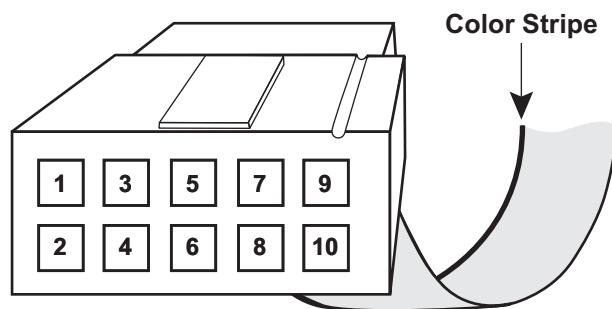

Figure 11 illustrates the 10-pin female header pinout for the ATF15xx ISP Download Cable. The 10-pin male header pinout on the PC board (if used for ISP) must match this pinout.

Figure 11. ATF15xx ISP Download Cable 10-pin Female Header Pinout



Note: The circuit board must supply V_{CC} and GND to the CPLD ISP Cable through the 10-pin male header.

Schematic Diagrams

Figure 12. ATF15xx-D3 Development/Programmer Kit Schematic Diagram

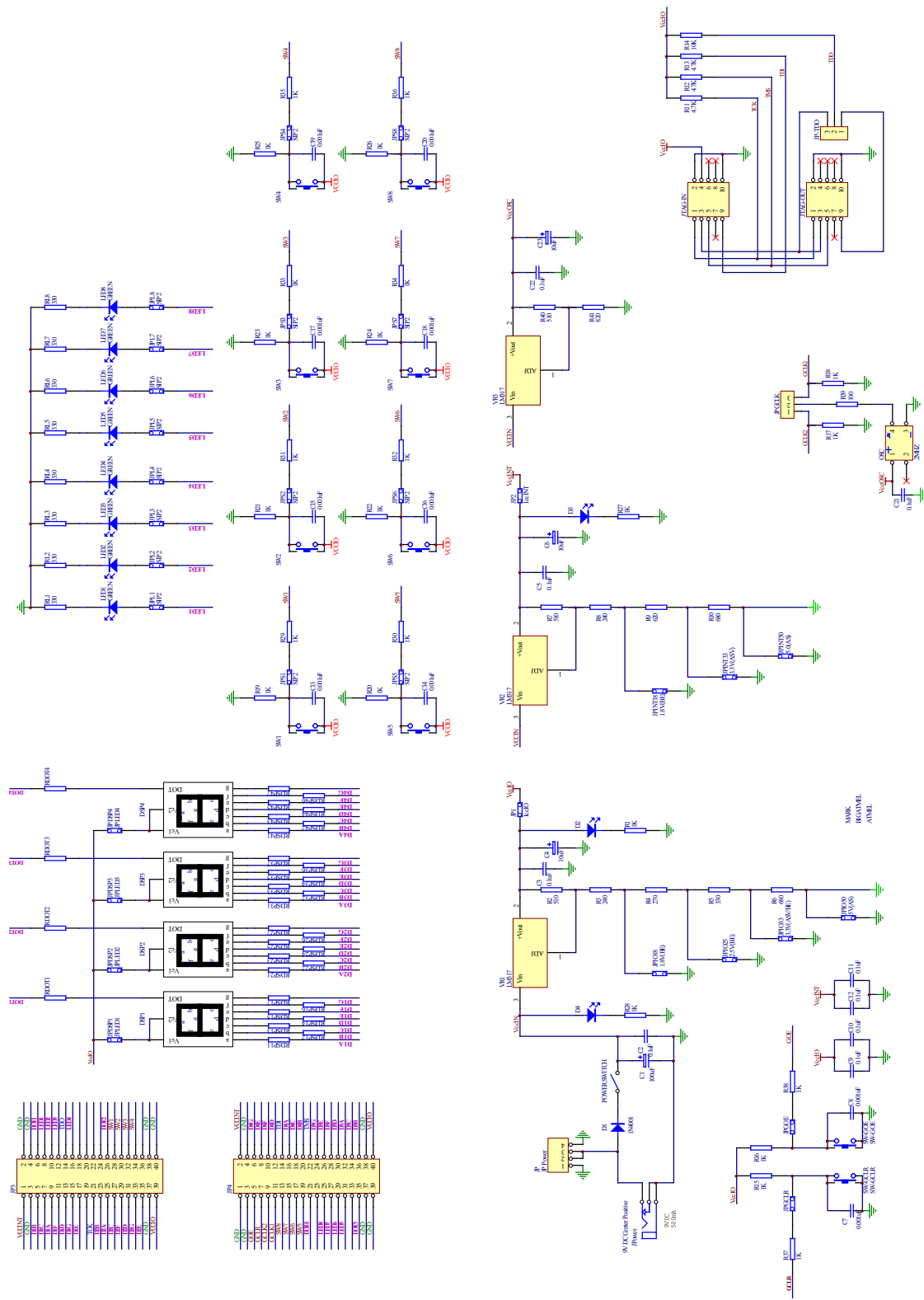

Figure 13. 44-pin TQFP Socket Adapter Board Schematic Diagram

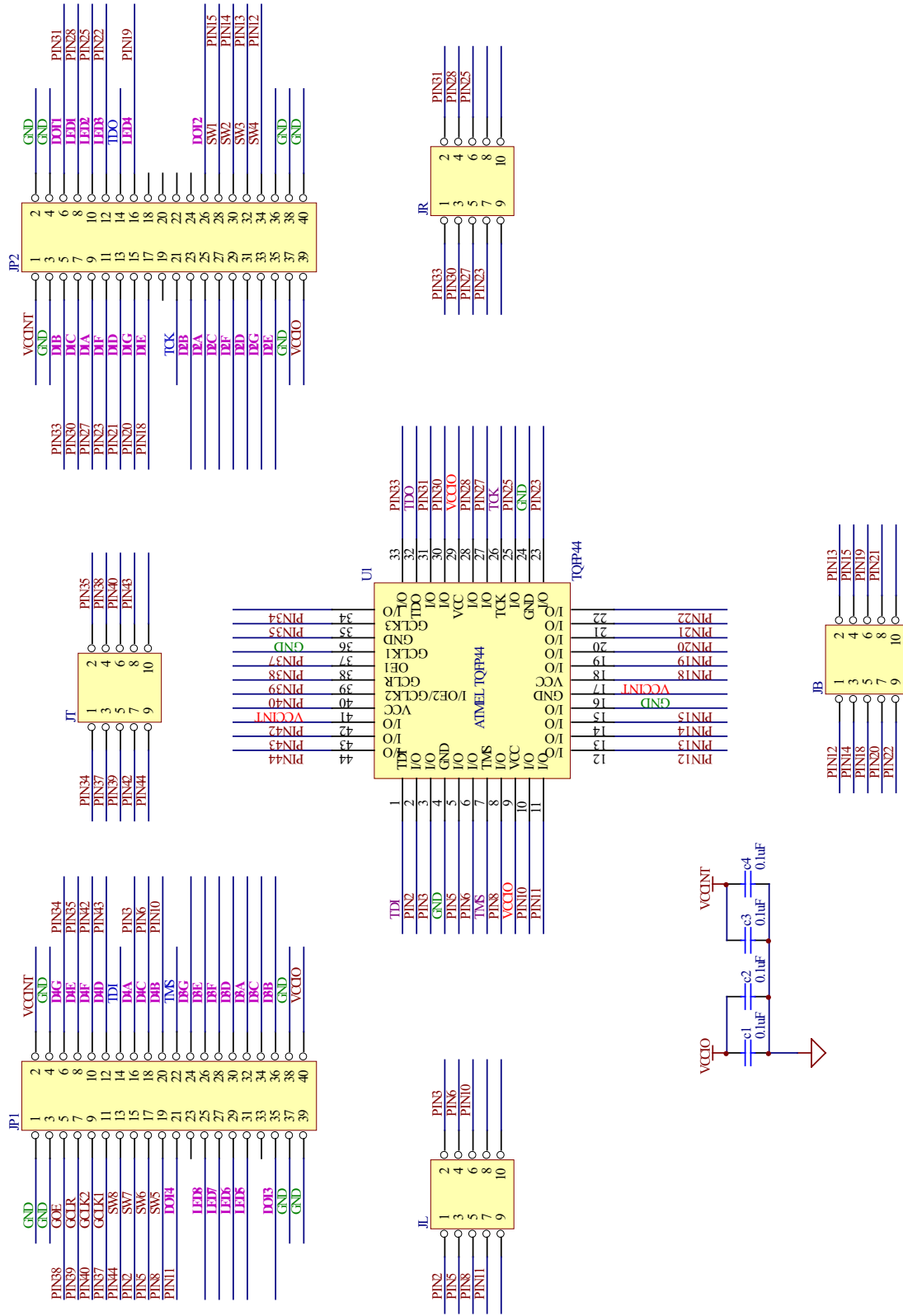

Figure 15. 84-pin PLCC Socket Adapter Board Schematic Diagram

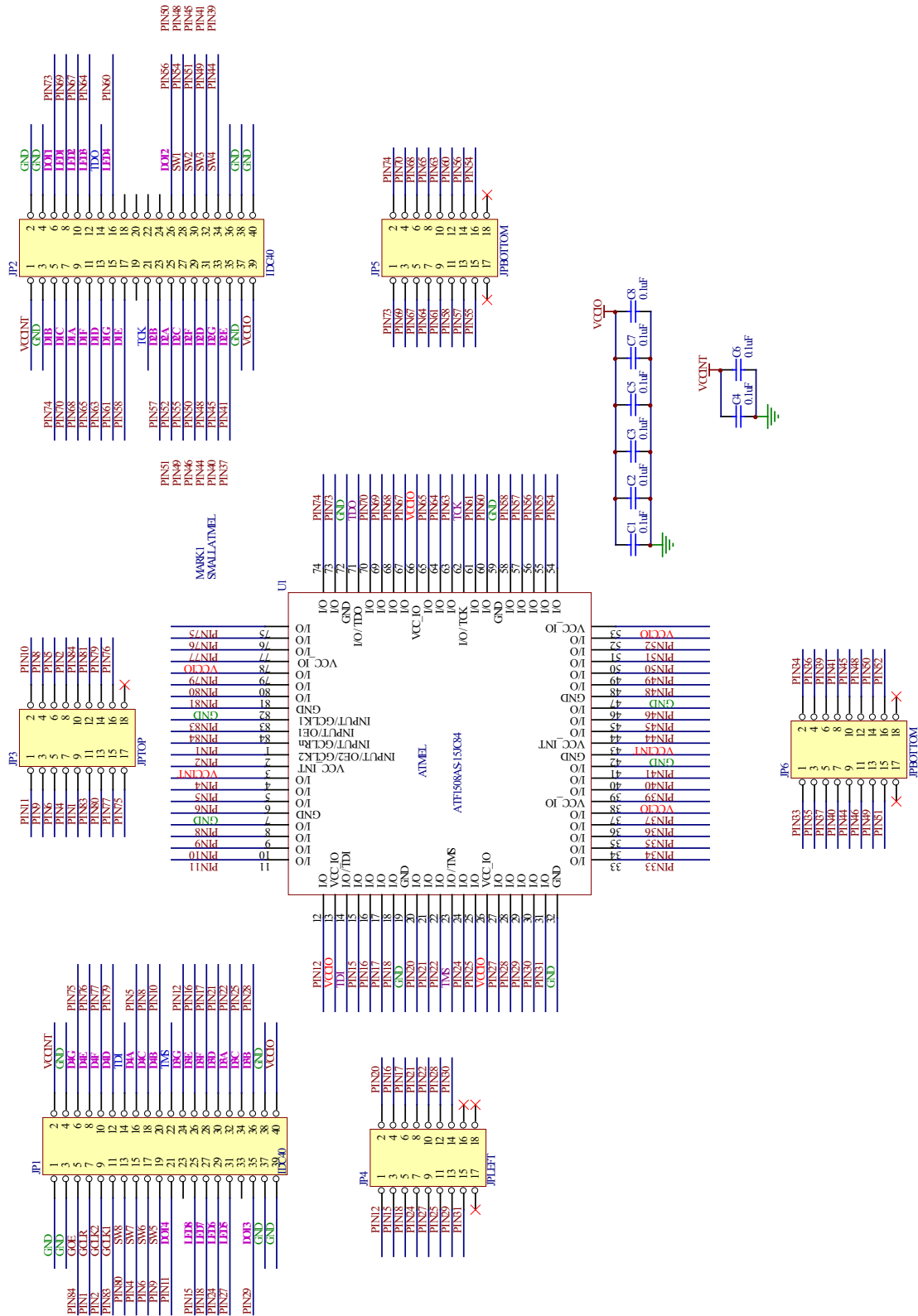
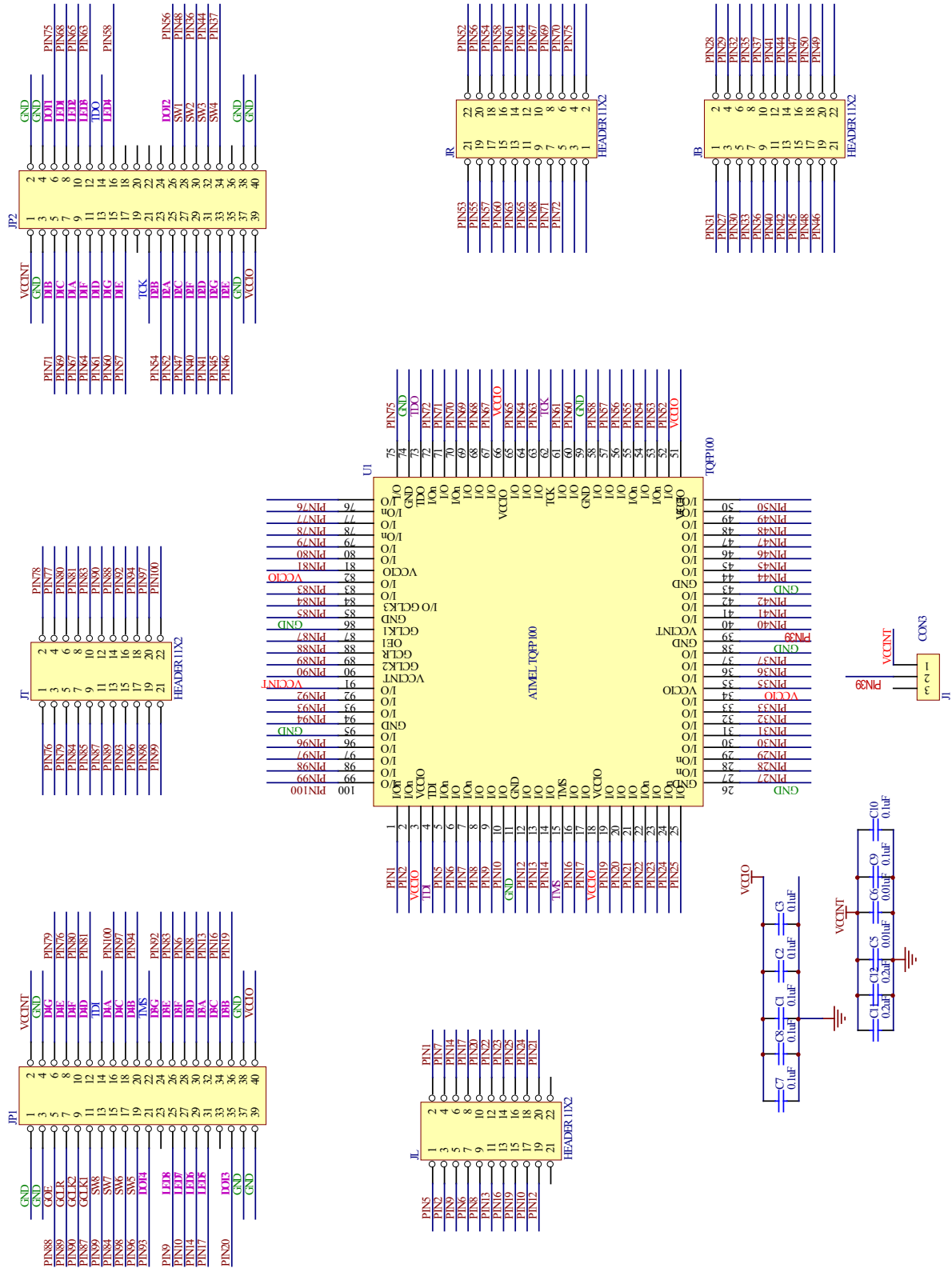

Figure 16. 100-pin TQFP Socket Adapter Board Schematic Diagram



References and Support

For additional PLD design software references and support, documentation such as help files, tutorials, application notes/briefs, and user guides are available at www.atmel.com.

Atmel ProChip Designer Software

Table 8. ProChip Designer References and Support

ProChip Designer	From the main ProChip window menu...
Help	Select Help > Prochip Designer Help .
Tutorials	Select Help > Tutorials .
Known Problems and Solutions	Select Help > Review KPS .

Atmel WinCUPL Software

Table 9. WinCUPL References and Support

WinCUPL	From the main WinCUPL window menu...
Help	Select Help > Contents .
CUPL Programmers Reference Guide	Select Help > CUPL Programmers Reference .
Tutorials	Select Help > Atmel Info > Tutorial1.pdf .
Known Problems and Solutions	Select Help > Atmel Info > CUPL_BUG.pdf .

Atmel ATMISP Software

Table 10. ATMISP References and Support

ATMISP	From the main ATMISP window menu...
Help Files	Select Help > ISP Help .
Tutorials	Select Help > ATMISP Tutorial .
Known Problems and Solutions	Using the Windows Explorer browser, locate the ATMISP folder and open the readme.txt file with an ASCII text editor.

Atmel POF2JED Conversion Software

Table 11. POF2JED References and Support

POF2JED	From the main POF2JED window menu...
ATF15xx Conversion Application Brief	Select Help > Conversion Options .

Technical Support

For technical support on any Atmel PLD related issues, contact the Atmel PLD Applications Group at:

Email pld@atmel.com

Hotline (+1)(408) 436-4333

Online Support Form <http://support.atmel.com/bin/customer.exe>

Revision History

Revision	Date	Description
3605C	06/2014	Update schematics, template, logos, and disclaimer page. Add the Revision History section.
3605B	05/2008	

Atmel®, Atmel logo and combinations thereof, Enabling Unlimited Possibilities, and others are registered trademarks or trademarks of Atmel Corporation in U.S. and other countries. Other terms and product names may be trademarks of others.

DISCLAIMER: The information in this document is provided in connection with Atmel products. No license, express or implied, by estoppel or otherwise, to any intellectual property right is granted by this document or in connection with the sale of Atmel products. EXCEPT AS SET FORTH IN THE ATMEL TERMS AND CONDITIONS OF SALES LOCATED ON THE ATMEL WEBSITE, ATMEL ASSUMES NO LIABILITY WHATSOEVER AND DISCLAIMS ANY EXPRESS, IMPLIED OR STATUTORY WARRANTY RELATING TO ITS PRODUCTS INCLUDING, BUT NOT LIMITED TO, THE IMPLIED WARRANTY OF MERCHANTABILITY, FITNESS FOR A PARTICULAR PURPOSE, OR NON-INFRINGEMENT. IN NO EVENT SHALL ATMEL BE LIABLE FOR ANY DIRECT, INDIRECT, CONSEQUENTIAL, PUNITIVE, SPECIAL OR INCIDENTAL DAMAGES (INCLUDING, WITHOUT LIMITATION, DAMAGES FOR LOSS AND PROFITS, BUSINESS INTERRUPTION, OR LOSS OF INFORMATION) ARISING OUT OF THE USE OR INABILITY TO USE THIS DOCUMENT, EVEN IF ATMEL HAS BEEN ADVISED OF THE POSSIBILITY OF SUCH DAMAGES. Atmel makes no representations or warranties with respect to the accuracy or completeness of the contents of this document and reserves the right to make changes to specifications and products descriptions at any time without notice. Atmel does not make any commitment to update the information contained herein. Unless specifically provided otherwise, Atmel products are not suitable for, and shall not be used in, automotive applications. Atmel products are not intended, authorized, or warranted for use as components in applications intended to support or sustain life.

SAFETY-CRITICAL, MILITARY, AND AUTOMOTIVE APPLICATIONS DISCLAIMER: Atmel products are not designed for and will not be used in connection with any applications where the failure of such products would reasonably be expected to result in significant personal injury or death ("Safety-Critical Applications") without an Atmel officer's specific written consent. Safety-Critical Applications include, without limitation, life support devices and systems, equipment or systems for the operation of nuclear facilities and weapons systems. Atmel products are not designed nor intended for use in military or aerospace applications or environments unless specifically designated by Atmel as military-grade. Atmel products are not designed nor intended for use in automotive applications unless specifically designated by Atmel as automotive-grade.

Looking for pricing, stock, or lifecycle information?

Click below to explore more details on WIN SOURCE:

- ⊖ [View ATF15XXDK3-SAA100 on WIN SOURCE](#)
- ⊖ [Microchip Technology](#) Information

Optimize Your Supply Chain with WIN SOURCE Solutions

- ✓ Global Sourcing Solution
- ✓ Obsolete Management
- ✓ Cost Control Management
- ✓ Shortage Management
- ✓ Alternative Solution
- ✓ Excess Inventory Management