



Section 1

ATAVRAUTOEK1 Getting Started

1.1 Unpacking the system

Kit contents:

- 1 ATAVRAUTO100 V1.0 board
- 1 ATAVRAUTO102 V1.0 board
- 1 ATAVRAUTO200 V1.0 board
- 1 ATAVRAUTO300 V1.0 board
- 1 ATAVRAUTO900 V1.0 board
- 5 Cables for board connection
- 1 USB Mini-B to A cable
- 1 Getting Started
- 1 Automotive CD-Rom
- 1 AVR CD-Rom software and technical library
- 1 Dear customer letter

Note: All boards are shipped with a demo firmware loaded. This guide gives you all keys to plug and play the ATAVRAUTO evaluation kit demo.

1.2 Overview

The ATAVRAUTOEK1 evaluation kit has been designed to give designers an easy and fast way to develop automotive applications. The evaluation kit is shipped with a board used as a vehicle network analyser (ATAVRAUTO102), a gateway between one LIN network to one CAN network (ATAVRAUTO100), a DC motor control board (ATAVRAUTO200) and a joystick board (ATAVRAUTO300).

The ATAVRAUTOEK1 evaluation kit is shipped with all boards connected together on the PCB (as describe in the following schematic):

- The ATAVRAUTO300 board is connected to the ATAVRAUTO102 board via the LIN0.
- The ATAVRAUTO100 board is connected to the ATAVRAUTO200 and to the ATAVRAUTO102 boards via the LIN1.
- Boards ATAVRAUTO100 and ATAVRAUTO102 are connected together via the CAN.

Figure 1-1. Evaluation kit

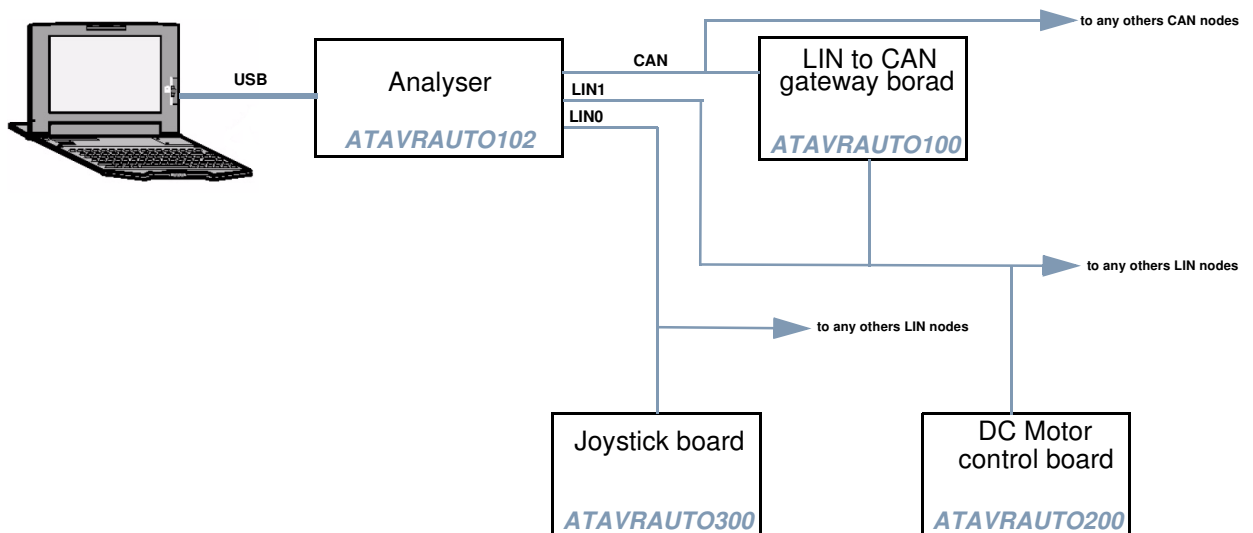

An 10-pins connector is available on the PCB to access internal signals. The pinout is as following:

Figure 1-2. 10-pins connector pinout

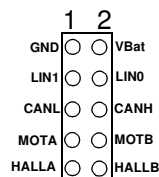

1.3 Quick Start The ATAVRAUTOEK1 evaluation kit contains 3 application boards (ATAVRAUTO100 /200 /300) and one board used as a tool(ATAVRAUTO102). All boards are shipped with a demo firmware loaded. To run the demo all boards have to be connected to one LIN. Please follow one of the two solutions described below.

1.3.1 With all boards connected to the PCB This is the easiest way to start with the ATAVRAUTO evaluation kit. Plug the motor in the ATAVRAUTO200 connector or in the 10-pins connector on the PCB, add a DC voltage source (8 to 18V) to VBat. The ATAVRAUTO evaluation kit is shipped with the jumper connected to the pin3 and pin4 (LIN0 and LIN1 are connected together).

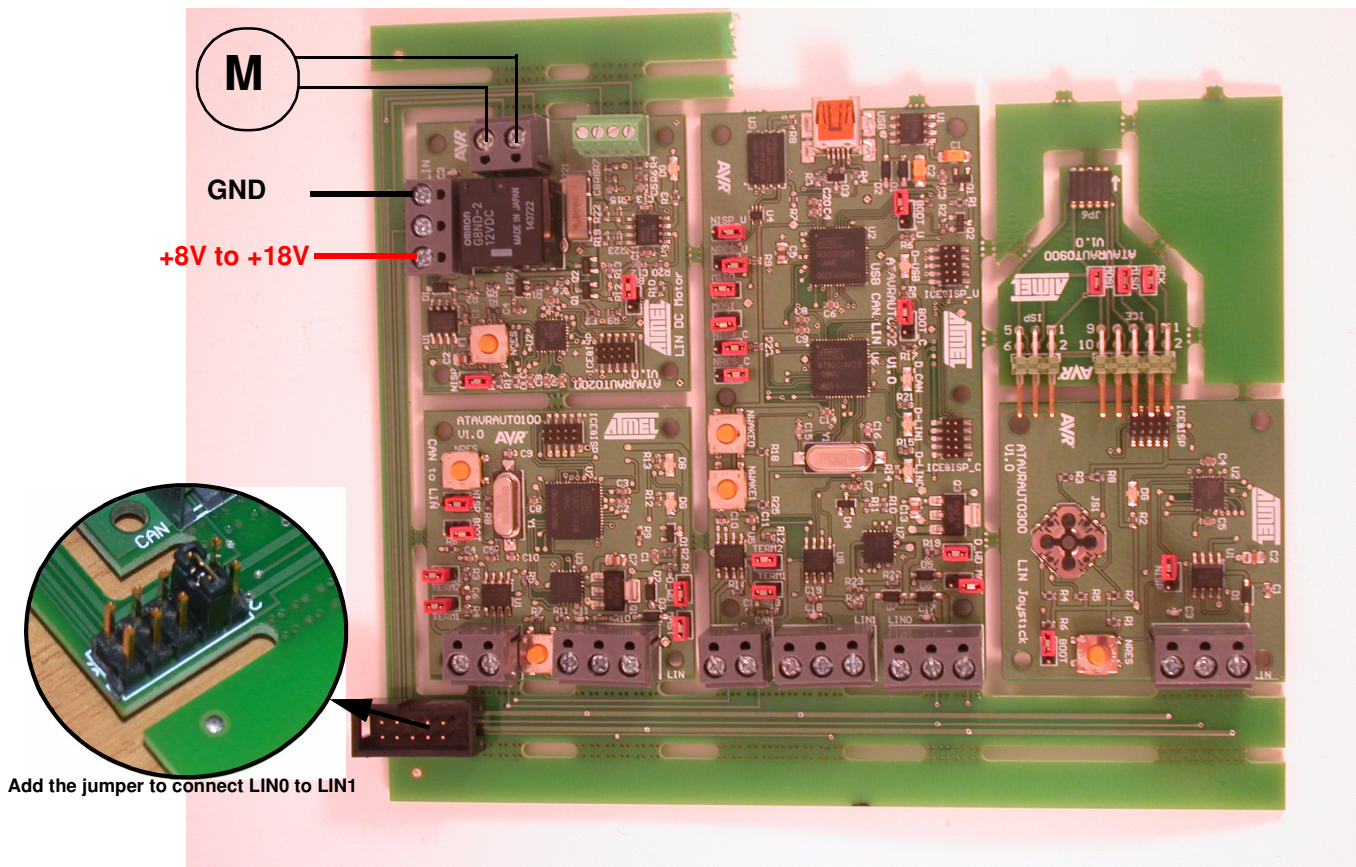

Finally plug the evaluation kit to your PC via the USB cable to analyse LIN and CAN networks with X-Analyzer.

1.3.2 With standalone boards

Connect your board as indicated below using the cables included in the kit and connect a DC voltage source (8 to 18V) to VBat.

Figure 1-3. ATAVRAUTOx Boards connection

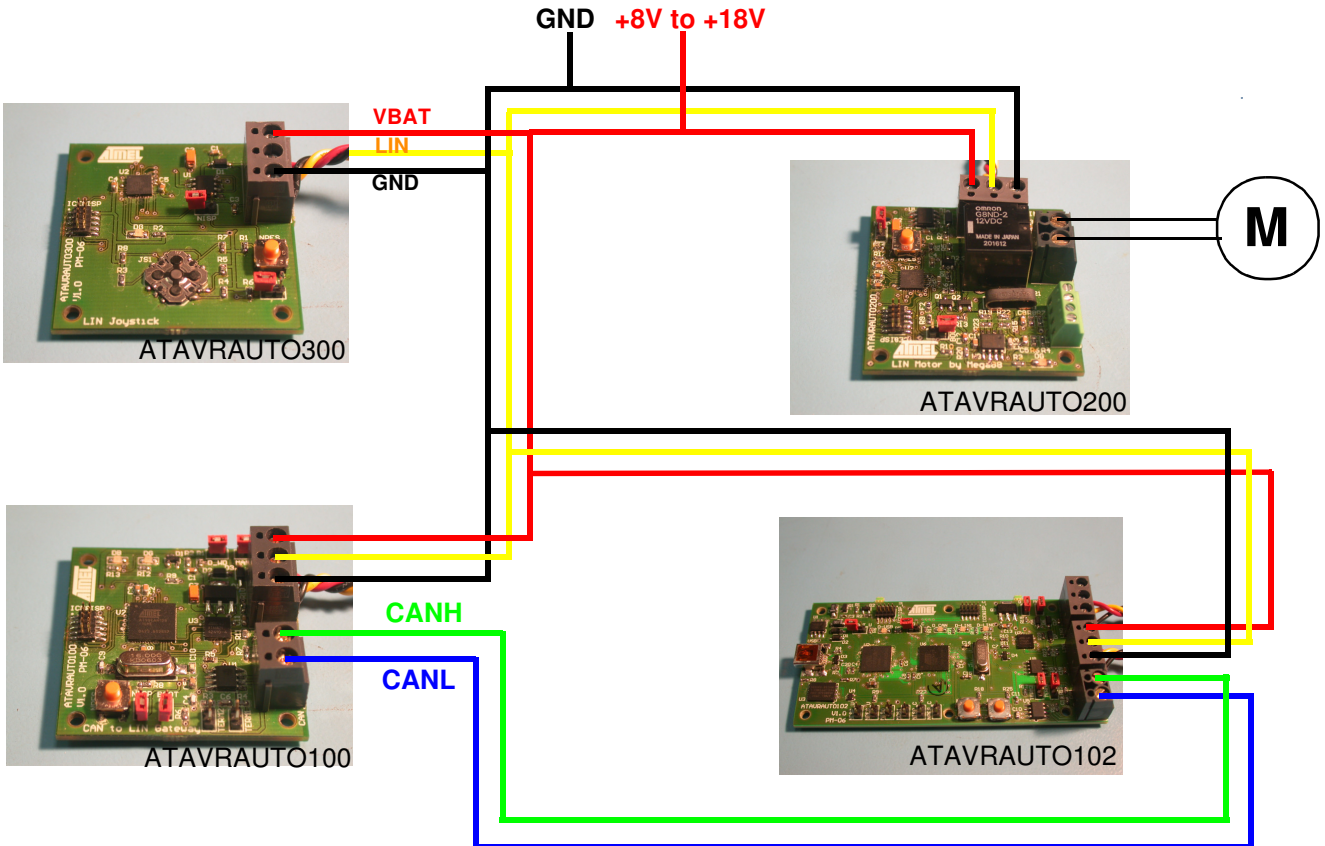

You are now ready to run the demo:

- Press the left or right button of the joystick to operate the DC Motor forward or backward.
- Use X-Analyser with the ATAVRAUTO102 to send CAN frame to gateway board to get the motor current and the motor power supply values.

Table 1-1. Standard CAN frames to send to the gateway

Name	Type	Identificateur	Length
Get_Current	Remote	0x05	0
Get_Power_Supply	Remote	0x06	0

- Use X-Analyser with the ATAVRAUTO102 to analyse the LIN bus.

Table 1-2. LIN frames available on the LIN network

Name	Identifier	Function
NET_CTRL	0x01	Get motor information from the joystick
DC_INFO	0x22	Return DC motor power supply value and current value to the gateway



Atmel Corporation

2325 Orchard Parkway
San Jose, CA 95131, USA
Tel: 1(408) 441-0311
Fax: 1(408) 487-2600

Regional Headquarters

Europe

Atmel Sarl
Route des Arsenalux 41
Case Postale 80
CH-1705 Fribourg
Switzerland
Tel: (41) 26-426-5555
Fax: (41) 26-426-5500

Asia

Room 1219
Chinachem Golden Plaza
77 Mody Road Tsimshatsui
East Kowloon
Hong Kong
Tel: (852) 2721-9778
Fax: (852) 2722-1369

Japan

9F, Tonetsu Shinkawa Bldg.
1-24-8 Shinkawa
Chuo-ku, Tokyo 104-0033
Japan
Tel: (81) 3-3523-3551
Fax: (81) 3-3523-7581

Atmel Operations

Memory

2325 Orchard Parkway
San Jose, CA 95131, USA
Tel: 1(408) 441-0311
Fax: 1(408) 436-4314

Microcontrollers

2325 Orchard Parkway
San Jose, CA 95131, USA
Tel: 1(408) 441-0311
Fax: 1(408) 436-4314

La Chantrerie
BP 70602
44306 Nantes Cedex 3, France
Tel: (33) 2-40-18-18-18
Fax: (33) 2-40-18-19-60

ASIC/ASSP/Smart Cards

Zone Industrielle
13106 Rousset Cedex, France
Tel: (33) 4-42-53-60-00
Fax: (33) 4-42-53-60-01

1150 East Cheyenne Mtn. Blvd.
Colorado Springs, CO 80906, USA
Tel: 1(719) 576-3300
Fax: 1(719) 540-1759

Scottish Enterprise Technology Park
Maxwell Building
East Kilbride G75 0QR, Scotland
Tel: (44) 1355-803-000
Fax: (44) 1355-242-743

RF/Automotive

Theresienstrasse 2
Postfach 3535
74025 Heilbronn, Germany
Tel: (49) 71-31-67-0
Fax: (49) 71-31-67-2340

1150 East Cheyenne Mtn. Blvd.
Colorado Springs, CO 80906, USA
Tel: 1(719) 576-3300
Fax: 1(719) 540-1759

Biometrics/Imaging/Hi-Rel MPU/ High Speed Converters/RF Datacom

Avenue de Rochepleine
BP 123
38521 Saint-Egreve Cedex, France
Tel: (33) 4-76-58-30-00
Fax: (33) 4-76-58-34-80

Literature Requests

www.atmel.com/literature

Disclaimer: Atmel Corporation makes no warranty for the use of its products, other than those expressly contained in the Company's standard warranty which is detailed in Atmel's Terms and Conditions located on the Company's web site. The Company assumes no responsibility for any errors which may appear in this document, reserves the right to change devices or specifications detailed herein at any time without notice, and does not make any commitment to update the information contained herein. No licenses to patents or other intellectual property of Atmel are granted by the Company in connection with the sale of Atmel products, expressly or by implication. Atmel's products are not authorized for use as critical components in life support devices or systems.

© 2007 Atmel Corporation. All rights reserved. Atmel®, logo and combinations thereof, are registered trademarks or trademarks of Atmel Corporation or its subsidiaries. Windows® and others are registered trademarks or trademarks of Microsoft Corporation in the US and/or other countries. Other terms and product names may be trademarks of others.



Printed on recycled paper.

Looking for pricing, stock, or lifecycle information?

Click below to explore more details on WIN SOURCE:

 [View ATAVRAUTOEK1 on WIN SOURCE](#)

 [Microchip Technology](#) Information

Optimize Your Supply Chain with WIN SOURCE Solutions

-  Global Sourcing Solution
-  Obsolete Management
-  Cost Control Management
-  Shortage Management
-  Alternative Solution
-  Excess Inventory Management