

Features

- Two Different IF Receiving Bandwidth Versions Are Available ($B_{IF} = 300$ kHz or 600 kHz)
- Frequency Receiving Range of $f_0 = 868$ MHz to 870 MHz or $f_0 = 902$ MHz to 928 MHz
- 30 dB Image Rejection
- Receiving Bandwidth $B_{IF} = 600$ kHz for Low Cost 90-ppm Crystals and $B_{IF} = 300$ kHz for 55 ppm Crystals
- Fully Integrated LC-VCO and PLL Loop Filter
- Very High Sensitivity with Power Matched LNA
- High System IIP3 (-16 dBm), System 1-dB Compression Point (-25 dBm)
- High Large-signal Capability at GSM Band (Blocking -30 dBm at $+20$ MHz, IIP3 = -12 dBm at $+20$ MHz)
- 5V to 20V Automotive Compatible Data Interface
- Data Clock Available for Manchester- and Bi-phase-coded Signals
- Programmable Digital Noise Suppression
- Low Power Consumption Due to Configurable Polling
- Temperature Range -40°C to $+105^{\circ}\text{C}$
- ESD Protection 2 kV HBM, All Pins
- Communication to Microcontroller Possible Via a Single Bi-directional Data Line
- Low-cost Solution Due to High Integration Level with Minimum External Circuitry Requirements

1. Description

The ATA5760/ATA5761 is a multi-chip PLL receiver device supplied in an SO20 package. It has been especially developed for the demands of RF low-cost data transmission systems with data rates from 1 kBaud to 10 kBaud in Manchester or Bi-phase code. The receiver is well suited to operate with the Atmel's PLL RF transmitter T5750. Its main applications are in the areas of telemetering, security technology and keyless-entry systems. It can be used in the frequency receiving range of $f_0 = 868$ MHz to 870 MHz or $f_0 = 902$ MHz to 928 MHz for ASK or FSK data transmission. All the statements made below refer to 868.3 MHz and 915.0 MHz applications.

Figure 1-1. System Block Diagram

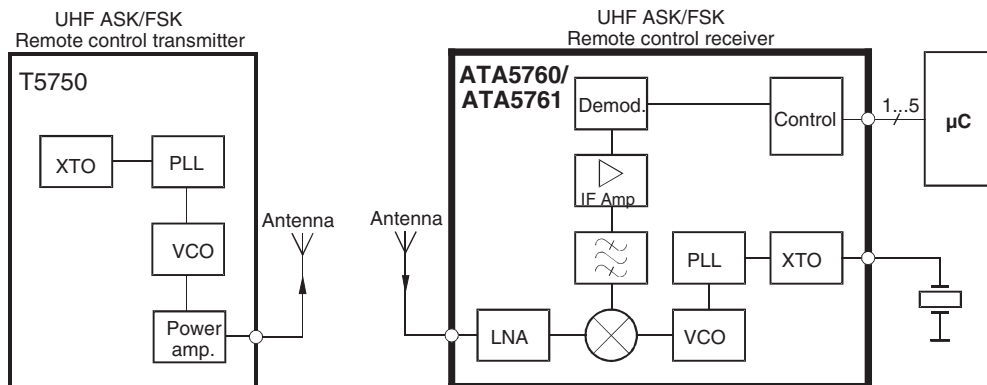

UHF ASK/FSK Receiver

ATA5760
ATA5761



Figure 1-2. Block Diagram

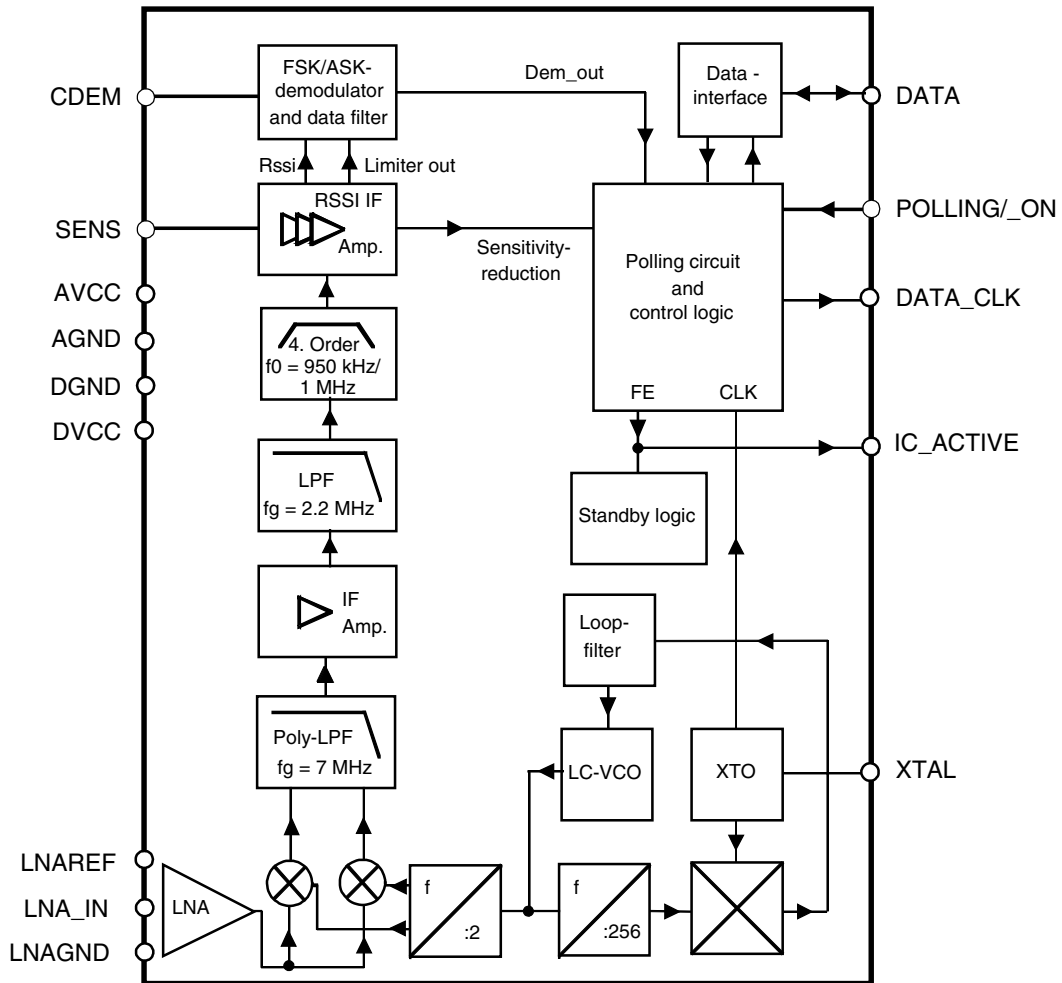

2. Pin Configuration

Figure 2-1. Pinning SO20

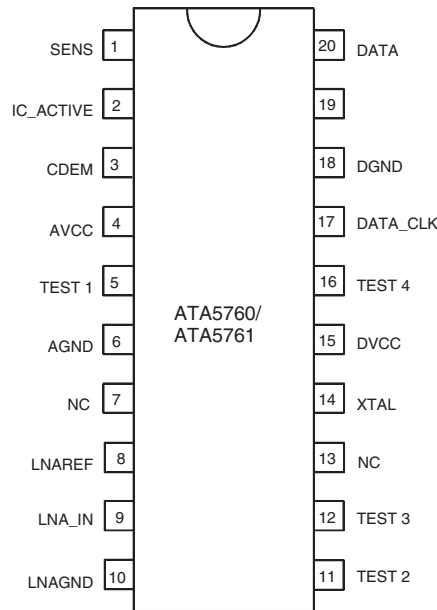

Table 2-1. Pin Description

Pin	Symbol	Function
1	SENS	Sensitivity-control resistor
2	IC_ACTIVE	IC condition indicator: Low = sleep mode, High = active mode
3	CDEM	Lower cut-off frequency data filter
4	AVCC	Analog power supply
5	TEST 1	Test pin, during operation at GND
6	AGND	Analog ground
7	NC	Not connected, connect to GND
8	LNAREF	High-frequency reference node LNA and mixer
9	LNA_IN	RF input
10	LNAGND	DC ground LNA and mixer
11	TEST 2	Do not connect during operating
12	TEST 3	Test pin, during operation at GND
13	NC	Not connected, connect to GND
14	XTAL	Crystal oscillator XTAL connection
15	DVCC	Digital power supply
16	TEST 4	Test pin, during operation at DVCC
17	DATA_CLK	Bit clock of data stream
18	DGND	Digital ground
19	POLLING/_ON	Selects polling or receiving mode; Low: receiving mode, High: polling mode
20	DATA	Data output/configuration input

3. RF Front End

The RF front end of the receiver is a low-IF heterodyne configuration that converts the input signal into an about 1 MHz IF signal with an image rejection of typical 30 dB. According to [Figure 2-1 on page 3](#) the front end consists of an LNA (Low Noise Amplifier), LO (Local Oscillator), I/Q mixer, polyphase lowpass filter and an IF amplifier.

The PLL generates the carrier frequency for the mixer via a full integrated synthesizer with integrated low noise LC-VCO (Voltage Controlled Oscillator) and PLL-loop filter. The XTO (crystal oscillator) generates the reference frequency f_{XTO} . The integrated LC-VCO generates two times the mixer drive frequency f_{VCO} . The I/Q signals for the mixer are generated with a divide by two circuit ($f_{LO} = f_{VCO}/2$). f_{VCO} is divided by a factor of 256 and feeds into a phase frequency detector and compared with f_{XTO} . The output of the phase frequency detector is fed into an integrated loop filter and thereby generates the control voltage for the VCO. If f_{LO} is determined, f_{XTO} can be calculated using the following formula:

$$f_{XTO} = f_{LO}/128$$

The XTO is a one-pin oscillator that operates at the series resonance of the quartz crystal with high current but low voltage signal, so that there is only a small voltage at the crystal oscillator frequency at pin XTAL. According to [Figure 3-1](#), the crystal should be connected to GND with a series capacitor C_L . The value of that capacitor is recommended by the crystal supplier. Due to a somewhat inductive impedance at steady state oscillation and some PCB parasitics a lower value of C_L is normally necessary.

The value of C_L should be optimized for the individual board layout to achieve the exact value of f_{XTO} (the best way is to use a crystal with known load resonance frequency to find the right value for this capacitor) and hereby of f_{LO} . When designing the system in terms of receiving bandwidth and local oscillator accuracy, the accuracy of the crystal and the XTO must be considered.

If a crystal with ± 30 ppm adjustment tolerance at 25°C , ± 50 ppm over temperature -40°C to $+105^\circ\text{C}$, ± 10 ppm of total aging and a CM (motional capacitance) of 7 fF is used, an additional XTO pulling of ± 30 ppm has to be added.

The resulting total LO tolerance of ± 120 ppm agrees with the receiving bandwidth specification of the 600 kHz version of ATA5760/ATA5761 if the T5750 has also a total LO tolerance of ± 120 ppm.

For the ATA5760N3 crystals with ± 55 ppm total tolerance are needed for receiver and transmitter to cope with the reduced IF-bandwidth.

Figure 3-1. XTO Peripherals

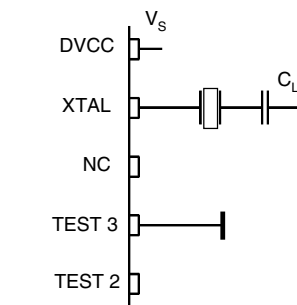

The nominal frequency f_{LO} is determined by the RF input frequency f_{RF} and the IF frequency f_{IF} using the following formula (low side injection):

$$f_{LO} = f_{RF} - f_{IF}$$

To determine f_{LO} , the construction of the IF filter must be considered at this point. The nominal IF frequency is $f_{IF} = 950$ kHz. To achieve a good accuracy of the filter corner frequencies, the filter is tuned by the crystal frequency f_{XTO} . This means that there is a fixed relation between f_{IF} and f_{LO} .

$$f_{IF} = f_{LO}/915 \text{ for } B_{IF} = 600 \text{ kHz}$$

$$f_{IF} = f_{LO}/878 \text{ for } B_{IF} = 300 \text{ kHz}$$

The relation is designed to achieve the nominal IF frequency of

$f_{IF} = 950$ kHz for the 868.3 MHz and $B_{IF} = 600$ kHz version,

$f_{IF} = 989$ kHz for the 868.3 MHz and $B_{IF} = 300$ kHz version and

for the 915 MHz version an IF frequency of $f_{IF} = 1.0$ MHz results.

The RF input either from an antenna or from an RF generator must be transformed to the RF input pin LNA_IN. The input impedance of that pin is provided in the electrical parameters. The parasitic board inductances and capacitances influence the input matching. The RF receiver ATA5760/ATA5761 exhibits its highest sensitivity if the LNA is power matched. This makes the matching to an SAW filter as well as to 50Ω or an antenna easier.

[Figure 14-1 on page 30](#) shows a typical input matching network for $f_{RF} = 868.3$ MHz to 50Ω . [Figure 14-2 on page 30](#) illustrates an according input matching for 868.3 MHz to an SAW. The input matching network shown in [Figure 14-1 on page 30](#) is the reference network for the parameters given in the electrical characteristics.

4. Analog Signal Processing

4.1 IF Filter

The signals coming from the RF front-end are filtered by the fully integrated 4th-order IF filter. The IF center frequency is

$f_{IF} = 950$ kHz for the 868.3 MHz and $B_{IF} = 600$ kHz version,
 $f_{IF} = 989$ kHz for the 868.3 MHz and $B_{IF} = 300$ kHz version and
 $f_{IF} = 1$ MHz for the 915 MHz version.

The nominal bandwidth is $B_{IF} = 600$ kHz for ATA5760/ATA5761 and $B_{IF} = 300$ kHz for ATA5760N3.

4.2 Limiting RSSI Amplifier

The subsequent RSSI amplifier enhances the output signal of the IF amplifier before it is fed into the demodulator. The dynamic range of this amplifier is $\Delta R_{RSSI} = 60$ dB. If the RSSI amplifier is operated within its linear range, the best S/N ratio is maintained in ASK mode. If the dynamic range is exceeded by the transmitter signal, the S/N ratio is defined by the ratio of the maximum RSSI output voltage and the RSSI output voltage due to a disturber. The dynamic range of the RSSI amplifier is exceeded if the RF input signal is about 60 dB higher compared to the RF input signal at full sensitivity.

In FSK mode the S/N ratio is not affected by the dynamic range of the RSSI amplifier, because only the hard limited signal from a high gain limiting amplifier is used by the demodulator.

The output voltage of the RSSI amplifier is internally compared to a threshold voltage V_{Th_red} . V_{Th_red} is determined by the value of the external resistor R_{Sens} . R_{Sens} is connected between pin SENS and GND or V_S . The output of the comparator is fed into the digital control logic. By this means it is possible to operate the receiver at a lower sensitivity.

If R_{Sens} is connected to GND, the receiver switches to full sensitivity. It is also possible to connect the pin SENS directly to GND to get the maximum sensitivity.

If R_{Sens} is connected to V_S , the receiver operates at a lower sensitivity. The reduced sensitivity is defined by the value of R_{Sens} , the maximum sensitivity by the signal-to-noise ratio of the LNA input. The reduced sensitivity depends on the signal strength at the output of the RSSI amplifier.

Since different RF input networks may exhibit slightly different values for the LNA gain, the sensitivity values given in the electrical characteristics refer to a specific input matching. This matching is illustrated in [Figure 14-1 on page 30](#) and exhibits the best possible sensitivity and at the same time power matching at RF_IN.

R_{Sens} can be connected to V_S or GND via a microcontroller. The receiver can be switched from full sensitivity to reduced sensitivity or vice versa at any time. In polling mode, the receiver will not wake up if the RF input signal does not exceed the selected sensitivity. If the receiver is already active, the data stream at pin DATA will disappear when the input signal is lower than defined by the reduced sensitivity. Instead of the data stream, the pattern according to [Figure 4-1](#) is issued at pin DATA to indicate that the receiver is still active (see [Figure 13-2 on page 28](#)).

Figure 4-1. Steady L State Limited DATA Output Pattern



4.3 FSK/ASK Demodulator and Data Filter

The signal coming from the RSSI amplifier is converted into the raw data signal by the ASK/FSK demodulator. The operating mode of the demodulator is set via the bit ASK/_FSK in the OPMODE register. Logic L sets the demodulator to FSK, applying H to ASK mode.

In ASK mode an automatic threshold control circuit (ATC) is employed to set the detection reference voltage to a value where a good signal to noise ratio is achieved. This circuit also implies the effective suppression of any kind of in-band noise signals or competing transmitters. If the S/N (ratio to suppress in-band noise signals) exceeds about 10 dB the data signal can be detected properly, but better values are found for many modulation schemes of the competing transmitter.

The FSK demodulator is intended to be used for an FSK deviation of 10 kHz $\leq \Delta f \leq 100$ kHz. In FSK mode the data signal can be detected if the S/N (ratio to suppress in-band noise signals) exceeds about 2 dB. This value is valid for all modulation schemes of a disturber signal.

The output signal of the demodulator is filtered by the data filter before it is fed into the digital signal processing circuit. The data filter improves the S/N ratio as its passband can be adopted to the characteristics of the data signal. The data filter consists of a 1st-order high pass and a 2nd-order lowpass filter.

The highpass filter cut-off frequency is defined by an external capacitor connected to pin CDEM. The cut-off frequency of the highpass filter is defined by the following formula:

$$f_{cu_DF} = \frac{1}{2 \times \pi \times 30 \text{ k}\Omega \times \text{CDEM}}$$

In self-polling mode, the data filter must settle very rapidly to achieve a low current consumption. Therefore, CDEM cannot be increased to very high values if self-polling is used. On the other hand CDEM must be large enough to meet the data filter requirements according to the data signal. Recommended values for CDEM are given in the electrical characteristics.

The cut-off frequency of the lowpass filter is defined by the selected baud-rate range (BR_Range). The BR_Range is defined in the OPMODE register (refer to section [“Configuration of the Receiver” on page 23](#)). The BR_Range must be set in accordance to the used baud-rate.

The ATA5760/ATA5761 is designed to operate with data coding where the DC level of the data signal is 50%. This is valid for Manchester and Bi-phase coding. If other modulation schemes are used, the DC level should always remain within the range of $V_{DC_min} = 33\%$ and $V_{DC_max} = 66\%$. The sensitivity may be reduced by up to 2 dB in that condition.

Each BR_Range is also defined by a minimum and a maximum edge-to-edge time (t_{ee_sig}). These limits are defined in the electrical characteristics. They should not be exceeded to maintain full sensitivity of the receiver.

5. Receiving Characteristics

The RF receiver ATA5760/ATA5761 can be operated with and without a SAW front-end filter. In a typical automotive application, a SAW filter is used to achieve better selectivity and large signal capability. The receiving frequency response without a SAW front-end filter is illustrated in [Figure 5-1](#) and [Figure 5-2 on page 8](#). This example relates to ASK mode and the 600 kHz version ATA5760N3. FSK mode exhibits a similar behavior. The plots are printed relatively to the maximum sensitivity. If a SAW filter is used, an insertion loss of about 3 dB must be considered, but the overall selectivity is much better.

When designing the system in terms of receiving bandwidth, the LO deviation must be considered as it also determines the IF center frequency. The total LO deviation is calculated, to be the sum of the deviation of the crystal and the XTO deviation of the ATA5760/ATA5761. Low-cost crystals are specified to be within ± 90 ppm over tolerance, temperature and aging. The XTO deviation of the ATA5760/ATA5761 is an additional deviation due to the XTO circuit. This deviation is specified to be ± 30 ppm worst case for a crystal with $CM = 7$ fF. If a crystal of ± 90 ppm is used, the total deviation is ± 120 ppm in that case. Note that the receiving bandwidth and the IF-filter bandwidth are equivalent in ASK mode but not in FSK mode.

Figure 5-1. Narrow Band Receiving Frequency Response ($B_{IF} = 600$ kHz)

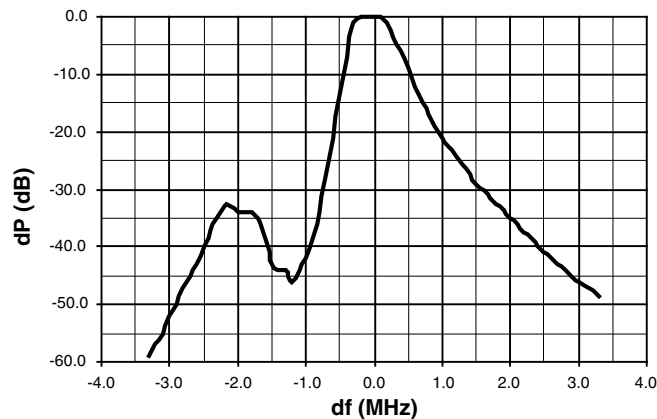
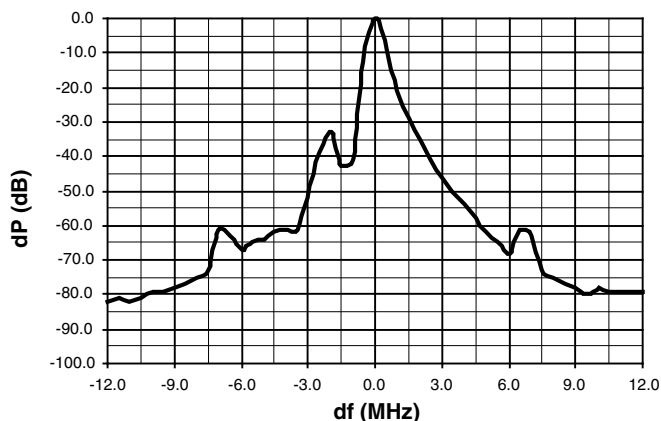

Figure 5-2. Wide Band Receiving Frequency Response ($B_{IF} = 600$ kHz)



6. Polling Circuit and Control Logic

The receiver is designed to consume less than 1 mA while being sensitive to signals from a corresponding transmitter. This is achieved via the polling circuit. This circuit enables the signal path periodically for a short time. During this time the bit-check logic verifies the presence of a valid transmitter signal. Only if a valid signal is detected, the receiver remains active and transfers the data to the connected microcontroller. If there is no valid signal present, the receiver is in sleep mode most of the time resulting in low current consumption. This condition is called polling mode. A connected microcontroller is disabled during that time.

All relevant parameters of the polling logic can be configured by the connected microcontroller. This flexibility enables the user to meet the specifications in terms of current consumption, system response time, data rate etc.

Regarding the number of connection wires to the microcontroller, the receiver is very flexible. It can be either operated by a single bi-directional line to save ports to the connected microcontroller or it can be operated by up to five uni-directional ports.

7. Basic Clock Cycle of the Digital Circuitry

The complete timing of the digital circuitry and the analog filtering is derived from one clock. This clock cycle T_{Clk} is derived from the crystal oscillator (XTO) in combination with a divide by 14 circuit. According to section “RF Front End” on page 4, the frequency of the crystal oscillator (f_{XTO}) is defined by the RF input signal (f_{RFIn}) which also defines the operating frequency of the local oscillator (f_{LO}). The basic clock cycle is $T_{\text{Clk}} = 14/f_{\text{XTO}}$ giving $T_{\text{Clk}} = 2.066 \mu\text{s}$ for $f_{\text{RF}} = 868.3 \text{ MHz}$ and $T_{\text{Clk}} = 1.961 \mu\text{s}$ for $f_{\text{RF}} = 915 \text{ MHz}$.

T_{Clk} controls the following application-relevant parameters:

- Timing of the polling circuit including bit check
- Timing of the analog and digital signal processing
- Timing of the register programming
- Frequency of the reset marker
- IF filter center frequency (f_{IF0})

Most applications are dominated by two transmission frequencies: $f_{\text{Transmit}} = 915 \text{ MHz}$ is mainly used in USA, $f_{\text{Transmit}} = 868.3 \text{ MHz}$ in Europe. In order to ease the usage of all T_{Clk} -dependent parameters on this electrical characteristics display three conditions for each parameter.

- Application USA ($f_{\text{XTO}} = 7.14063 \text{ MHz}$, $T_{\text{Clk}} = 1.961 \mu\text{s}$)
- Application Europe
 $(f_{\text{XTO}} = 6.77617 \text{ MHz}, T_{\text{Clk}} = 2.066 \mu\text{s})$ for $B_{\text{IF}} = 600 \text{ kHz}$
 $(f_{\text{XTO}} = 6.77587 \text{ MHz}, T_{\text{Clk}} = 2.066 \mu\text{s})$ for $B_{\text{IF}} = 300 \text{ kHz}$
- Other applications The electrical characteristic is given as a function of T_{Clk} .

The clock cycle of some function blocks depends on the selected baud-rate range (BR_Range) which is defined in the OPMODE register. This clock cycle T_{XClk} is defined by the following formulas for further reference:

BR_Range =	BR_Range0:	$T_{\text{XClk}} = 8 \times T_{\text{Clk}}$
	BR_Range1:	$T_{\text{XClk}} = 4 \times T_{\text{Clk}}$
	BR_Range2:	$T_{\text{XClk}} = 2 \times T_{\text{Clk}}$
	BR_Range3:	$T_{\text{XClk}} = 1 \times T_{\text{Clk}}$

8. Polling Mode

According to [Figure 8-4 on page 13](#), the receiver stays in polling mode in a continuous cycle of three different modes. In sleep mode the signal processing circuitry is disabled for the time period T_{Sleep} while consuming low current of $I_S = I_{\text{Soff}}$. During the start-up period, T_{Startup} , all signal processing circuits are enabled and settled. In the following bit-check mode, the incoming data stream is analyzed bit by bit contra a valid transmitter signal. If no valid signal is present, the receiver is set back to sleep mode after the period $T_{\text{Bit-check}}$. This period varies check by check as it is a statistical process. An average value for $T_{\text{Bit-check}}$ is given in the electrical characteristics. During T_{Startup} and $T_{\text{Bit-check}}$ the current consumption is $I_S = I_{\text{Son}}$. The condition of the receiver is indicated on pin IC_ACTIVE. The average current consumption in polling mode is dependent on the duty cycle of the active mode and can be calculated as:

$$S_{\text{poll}} = \frac{I_{\text{Soff}} \times T_{\text{Sleep}} + I_{\text{Son}} \times (T_{\text{Startup}} + T_{\text{Bit-check}})}{T_{\text{Sleep}} + T_{\text{Startup}} + T_{\text{Bit-check}}}$$

During T_{Sleep} and T_{Startup} the receiver is not sensitive to a transmitter signal. To guarantee the reception of a transmitted command the transmitter must start the telegram with an adequate preburst. The required length of the preburst depends on the polling parameters T_{Sleep} , T_{Startup} , $T_{\text{Bit-check}}$ and the start-up time of a connected microcontroller ($T_{\text{Start_microcontroller}}$). Thus, $T_{\text{Bit-check}}$ depends on the actual bit rate and the number of bits ($N_{\text{Bit-check}}$) to be tested.

The following formula indicates how to calculate the preburst length.

$$T_{\text{Purburst}} \geq T_{\text{Sleep}} + T_{\text{Startup}} + T_{\text{Bit-check}} + T_{\text{Start_microcontroller}}$$

8.1 Sleep Mode

The length of period T_{Sleep} is defined by the 5-bit word Sleep of the OPMODE register, the extension factor X_{Sleep} (according to [Table 11-8 on page 25](#)), and the basic clock cycle T_{Clk} . It is calculated to be:

$$T_{\text{Sleep}} = \text{Sleep} \times X_{\text{Sleep}} \times 1024 \times T_{\text{Clk}}$$

In US- and European applications, the maximum value of T_{Sleep} is about 60 ms if X_{Sleep} is set to 1. The time resolution is about 2 ms in that case. The sleep time can be extended to almost half a second by setting X_{Sleep} to 8. X_{Sleep} can be set to 8 by bit X_{SleepStd} to '1'.

According to [Table 11-7 on page 25](#), the highest register value of sleep sets the receiver into a permanent sleep condition. The receiver remains in that condition until another value for Sleep is programmed into the OPMODE register. This function is desirable where several devices share a single data line and may also be used for microcontroller polling – via pin POLLING/_ON, the receiver can be switched on and off.

Figure 8-1. Polling Mode Flow Chart

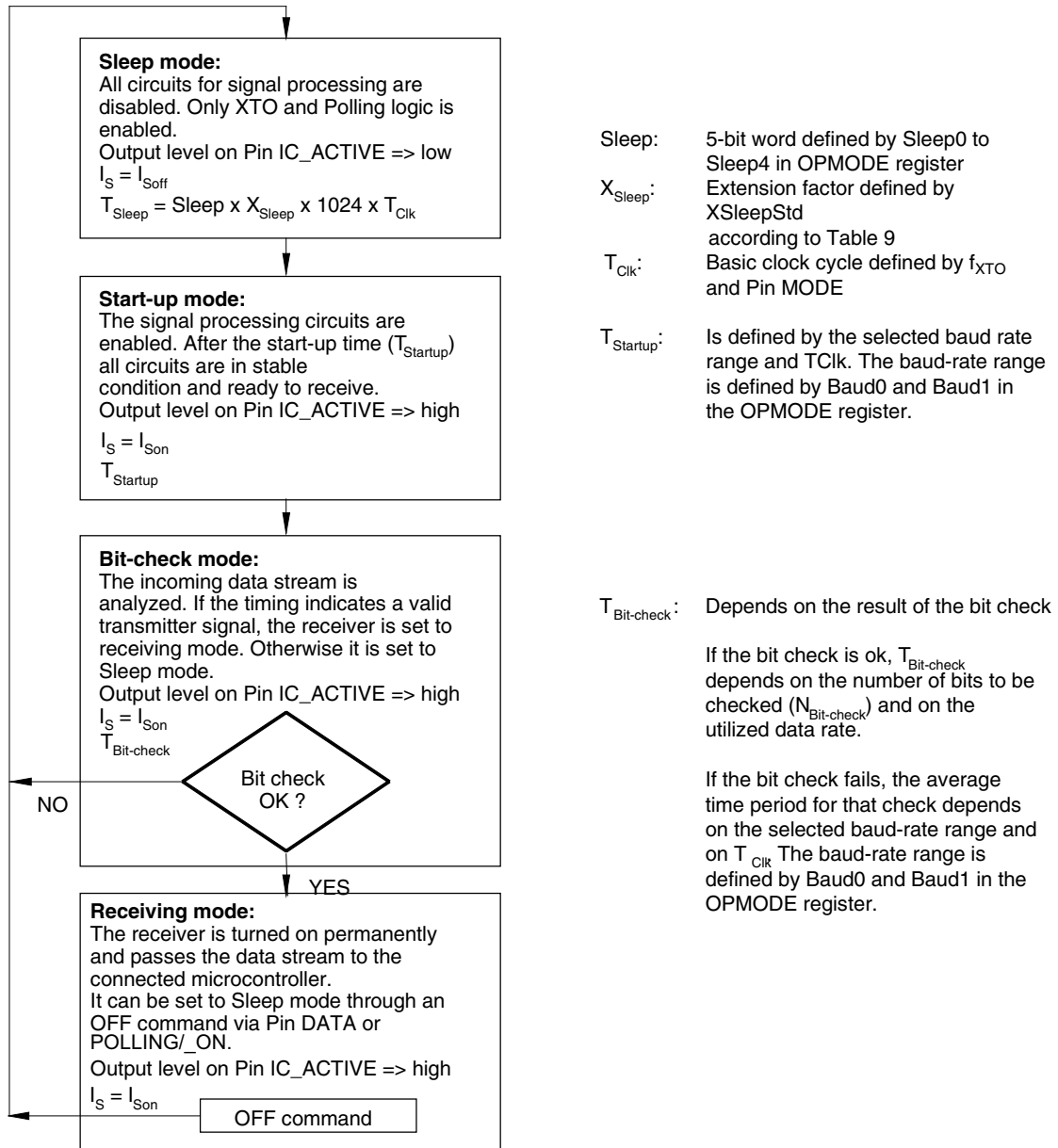
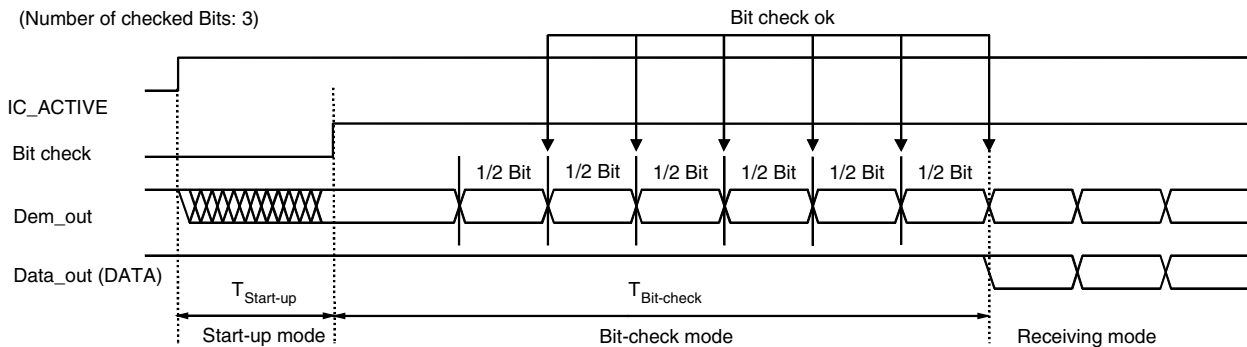

Figure 8-2. Timing Diagram for Complete Successful Bit Check



8.2 Bit-check Mode

In bit-check mode the incoming data stream is examined to distinguish between a valid signal from a corresponding transmitter and signals due to noise. This is done by subsequent time frame checks where the distances between 2 signal edges are continuously compared to a programmable time window. The maximum count of this edge-to-edge tests before the receiver switches to receiving mode is also programmable.

8.3 Configuring the Bit Check

Assuming a modulation scheme that contains 2 edges per bit, two time frame checks are verifying one bit. This is valid for Manchester, Bi-phase and most other modulation schemes. The maximum count of bits to be checked can be set to 0, 3, 6 or 9 bits via the variable $N_{\text{Bit-check}}$ in the OPMODE register. This implies 0, 6, 12 and 18 edge-to-edge checks respectively. If $N_{\text{Bit-check}}$ is set to a higher value, the receiver is less likely to switch to receiving mode due to noise. In the presence of a valid transmitter signal, the bit check takes less time if $N_{\text{Bit-check}}$ is set to a lower value. In polling mode, the bit-check time is not dependent on $N_{\text{Bit-check}}$. [Figure 8-2 on page 11](#) shows an example where 3 bits are tested successfully and the data signal is transferred to pin DATA.

According to [Figure 8-3](#), the time window for the bit check is defined by two separate time limits. If the edge-to-edge time t_{ee} is in between the lower bit-check limit $T_{\text{Lim_min}}$ and the upper bit-check limit $T_{\text{Lim_max}}$, the check will be continued. If t_{ee} is smaller than $T_{\text{Lim_min}}$ or t_{ee} exceeds $T_{\text{Lim_max}}$, the bit check will be terminated and the receiver switches to sleep mode.

Figure 8-3. Valid Time Window for Bit Check

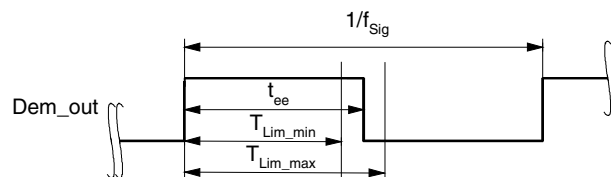

For best noise immunity it is recommended to use a low span between $T_{\text{Lim_min}}$ and $T_{\text{Lim_max}}$. This is achieved using a fixed frequency at a 50% duty cycle for the transmitter preburst. A '11111...' or a '10101...' sequence in Manchester or Bi-phase is a good choice concerning that advice. A good compromise between receiver sensitivity and susceptibility to noise is a time window of $\pm 30\%$ regarding the expected edge-to-edge time t_{ee} . Using pre-burst patterns that contain various edge-to-edge time periods, the bit-check limits must be programmed according to the required span.

The bit-check limits are determined by means of the formula below.

$$T_{\text{Lim_min}} = \text{Lim_min} \times T_{\text{XClk}}$$

$$T_{\text{Lim_max}} = (\text{Lim_max} - 1) \times T_{\text{XClk}}$$

Lim_min and Lim_max are defined by a 5-bit word each within the LIMIT register.

Using above formulas, Lim_min and Lim_max can be determined according to the required T_{Lim_min} , T_{Lim_max} and T_{XClk} . The time resolution defining T_{Lim_min} and T_{Lim_max} is T_{XClk} . The minimum edge-to-edge time t_{ee} ($t_{DATA_L_min}$, $t_{DATA_H_min}$) is defined according to the section “Receiving Mode” on page 14. The lower limit should be set to $Lim_min \geq 10$. The maximum value of the upper limit is $Lim_max = 63$.

If the calculated value for Lim_min is < 19 , it is recommended to check 6 or 9 bits ($N_{Bit-check}$) to prevent switching to receiving mode due to noise.

Figure 8-7 on page 15, Figure 8-8 and Figure 8-9 on page 15 illustrate the bit check for the bit-check limits $Lim_min = 14$ and $Lim_max = 24$. When the IC is enabled, the signal processing circuits are enabled during $T_{Startup}$. The output of the ASK/FSK demodulator (Dem_out) is undefined during that period. When the bit check becomes active, the bit-check counter is clocked with the cycle T_{XClk} .

Figure 8-7 on page 15 shows how the bit check proceeds if the bit-check counter value CV_Lim is within the limits defined by Lim_min and Lim_max at the occurrence of a signal edge. In Figure 8-8 on page 15 the bit check fails as the value CV_Lim is lower than the limit Lim_min. The bit check also fails if CV_Lim reaches Lim_max. This is illustrated in Figure 8-9 on page 15.

Figure 8-4. Timing Diagram During Bit Check

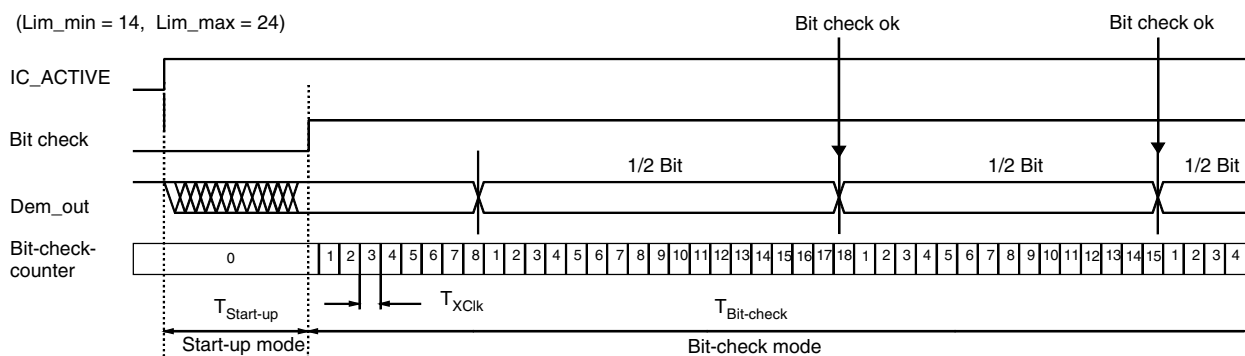

Figure 8-5. Timing Diagram for Failed Bit Check (Condition: $CV_Lim < Lim_min$)

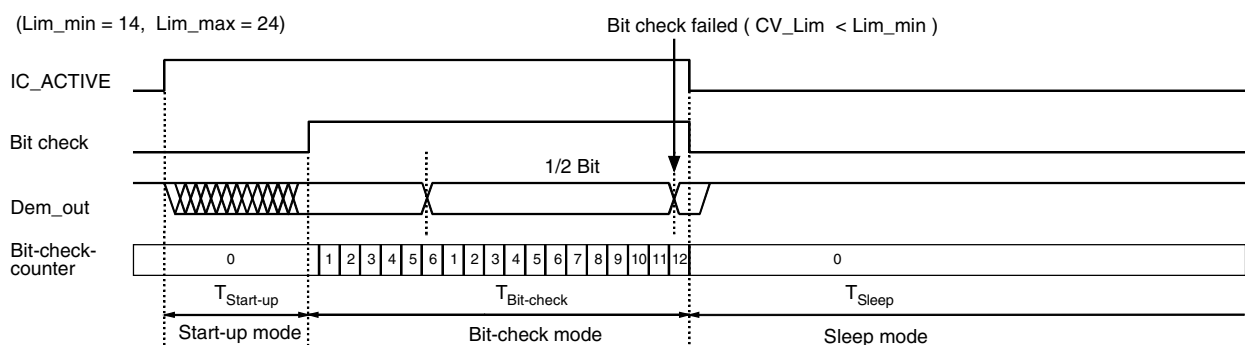
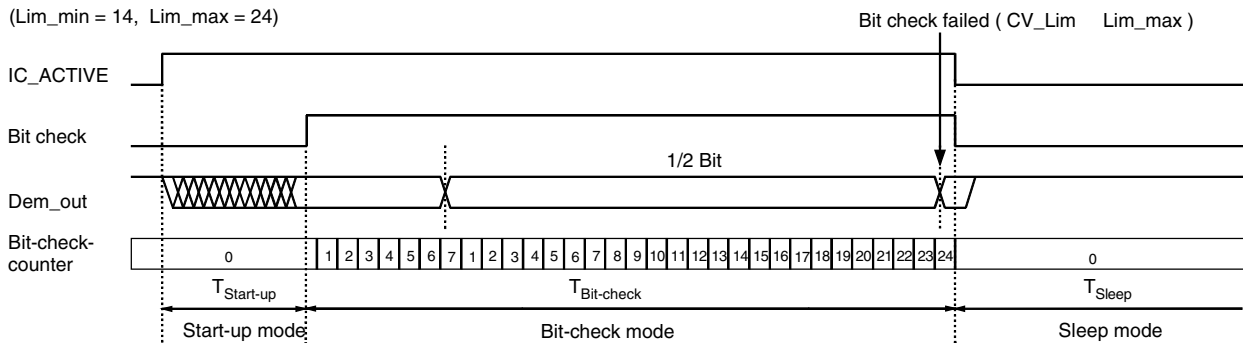

Figure 8-6. Timing Diagram for Failed Bit Check (Condition: $CV_Lim \geq Lim_max$)



8.4 Duration of the Bit Check

If no transmitter signal is present during the bit check, the output of the ASK/FSK demodulator delivers random signals. The bit check is a statistical process and $T_{\text{Bit-check}}$ varies for each check. Therefore, an average value for $T_{\text{Bit-check}}$ is given in the electrical characteristics. $T_{\text{Bit-check}}$ depends on the selected baud-rate range and on T_{Clk} . A higher baud-rate range causes a lower value for $T_{\text{Bit-check}}$ resulting in a lower current consumption in polling mode.

In the presence of a valid transmitter signal, $T_{\text{Bit-check}}$ is dependent on the frequency of that signal, f_{Sig} , and the count of the checked bits, $N_{\text{Bit-check}}$. A higher value for $N_{\text{Bit-check}}$ thereby results in a longer period for $T_{\text{Bit-check}}$ requiring a higher value for the transmitter pre-burst T_{Preburst} .

8.5 Receiving Mode

If the bit check was successful for all bits specified by $N_{\text{Bit-check}}$, the receiver switches to receiving mode. According to [Figure 8-2 on page 11](#), the internal data signal is switched to pin DATA in that case and the data clock is available after the start bit has been detected (see [Figure 9-1 on page 19](#)). A connected microcontroller can be woken up by the negative edge at pin DATA or by the data clock at pin DATA_CLK. The receiver stays in that condition until it is switched back to polling mode explicitly.

8.6 Digital Signal Processing

The data from the ASK/FSK demodulator (Dem_out) is digitally processed in different ways and as a result converted into the output signal data. This processing depends on the selected baud-rate range (BR_Range). [Figure 8-7](#) illustrates how Dem_out is synchronized by the extended clock cycle T_{XClk} . This clock is also used for the bit-check counter. Data can change its state only after T_{XClk} has elapsed. The edge-to-edge time period t_{ee} of the Data signal as a result is always an integral multiple of T_{XClk} .

The minimum time period between two edges of the data signal is limited to $t_{\text{ee}} \geq T_{\text{DATA_min}}$. This implies an efficient suppression of spikes at the DATA output. At the same time it limits the maximum frequency of edges at DATA. This eases the interrupt handling of a connected microcontroller.

The maximum time period for DATA to stay Low is limited to $T_{\text{DATA_L_max}}$. This function is employed to ensure a finite response time in programming or switching off the receiver via pin DATA. $T_{\text{DATA_L_max}}$ is thereby longer than the maximum time period indicated by the transmitter data stream. [Figure 8-9 on page 15](#) gives an example where Dem_out remains Low after the receiver has switched to receiving mode.

Figure 8-7. Synchronization of the Demodulator Output

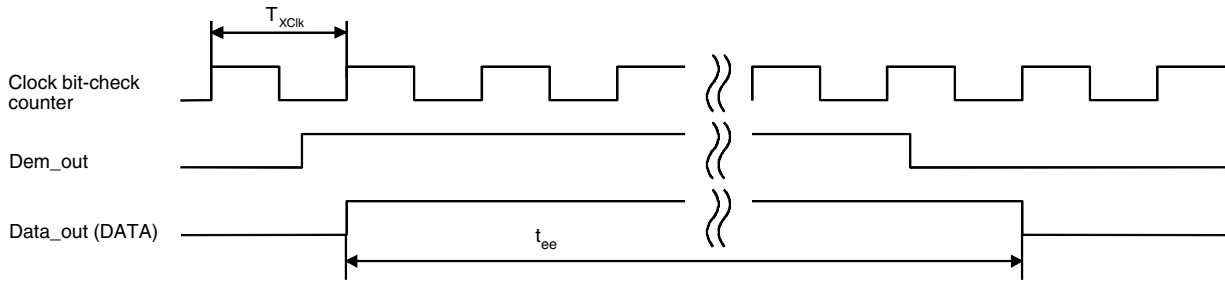

Figure 8-8. Debouncing of the Demodulator Output

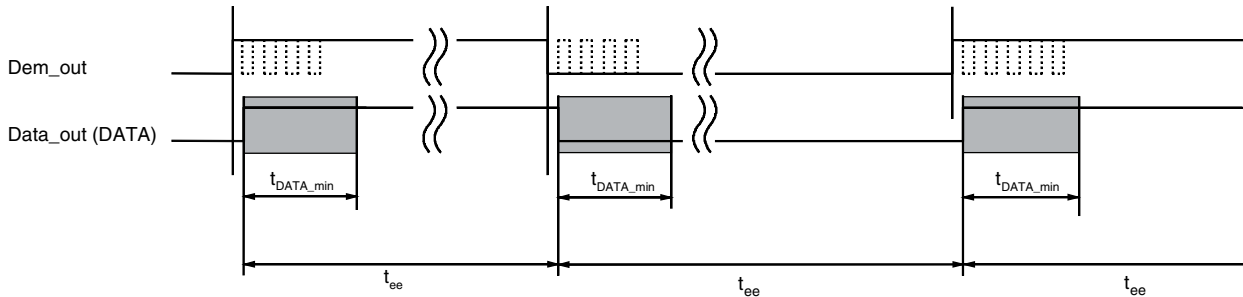
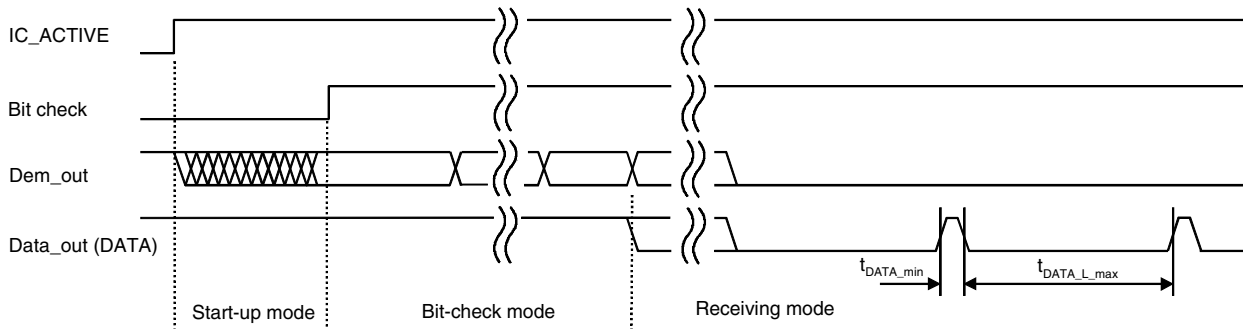

Figure 8-9. Steady L State Limited DATA Output Pattern After Transmission



After the end of a data transmission, the receiver remains active. Depending of the bit Noise_Disable in the OPMODE register, the output signal at pin DATA is high or random noise pulses appear at pin DATA (see section “Digital Noise Suppression” on page 21). The edge-to-edge time period t_{ee} of the majority of these noise pulses is equal or slightly higher than T_{DATA_min} .

8.7 Switching the Receiver Back to Sleep Mode

The receiver can be set back to polling mode via pin DATA or via pin POLLING/_ON.

When using pin DATA, this pin must be pulled to Low for the period t_1 by the connected microcontroller. [Figure 8-10 on page 16](#) illustrates the timing of the OFF command (see [Figure 13-2 on page 28](#)). The minimum value of t_1 depends on BR_Range. The maximum value for t_1 is not limited but it is recommended not to exceed the specified value to prevent erasing the reset marker. Note also that an internal reset for the OPMODE and the LIMIT register will be generated if t_1 exceeds the specified values. This item is explained in more detail in the section [“Configuration of the Receiver” on page 23](#). Setting the receiver to sleep mode via DATA is achieved by programming bit 1 to be ‘1’ during the register configuration. Only one sync pulse (t_3) is issued.

The duration of the OFF command is determined by the sum of t_1 , t_2 and t_{10} . After the OFF command the sleep time T_{Sleep} elapses. Note that the capacitive load at pin DATA is limited (see section [“Data Interface” on page 29](#)).

Figure 8-10. Timing Diagram of the OFF Command via Pin DATA

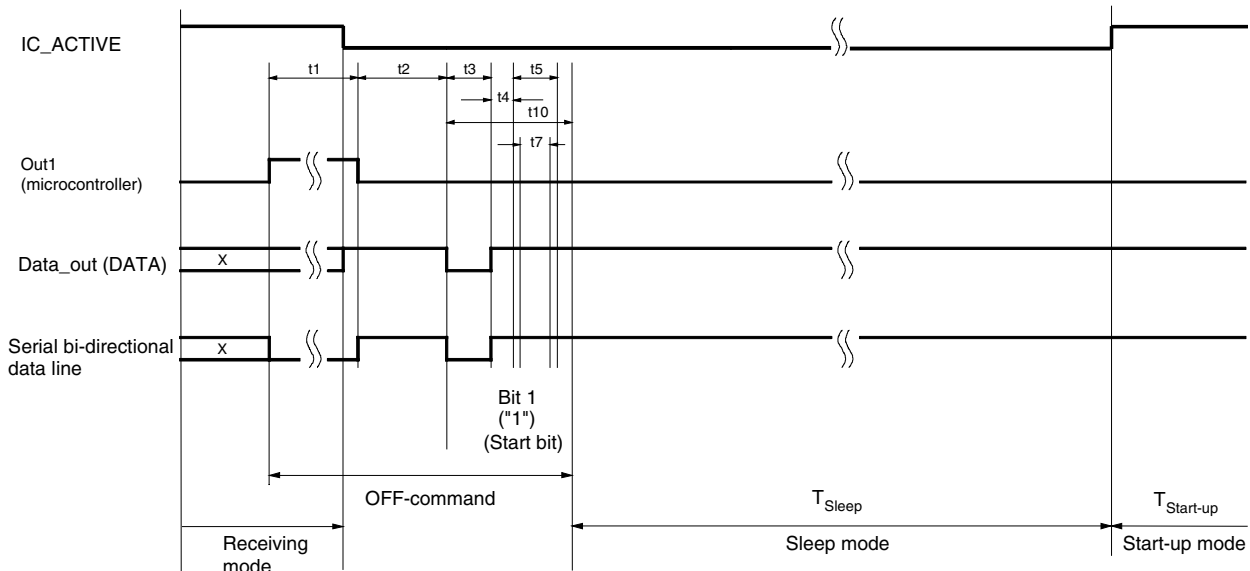

Figure 8-11. Timing Diagram of the OFF Command via Pin POLLING/_ON

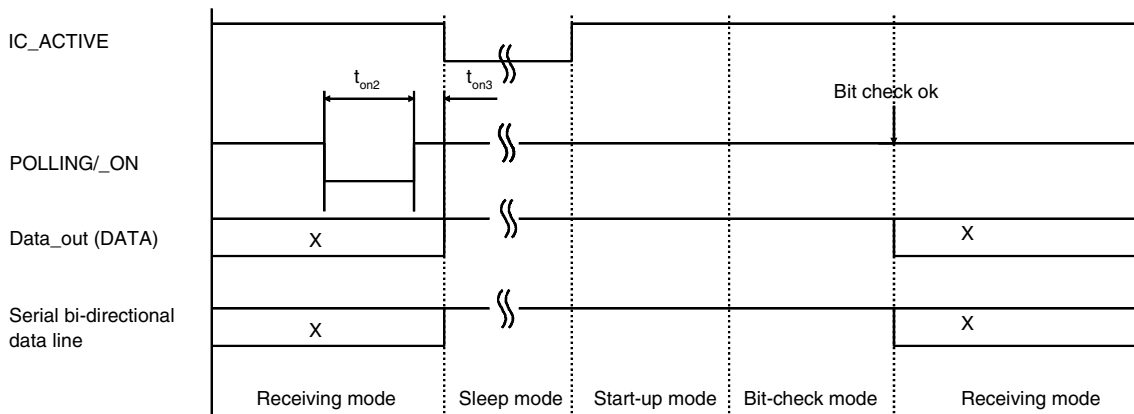

Figure 8-12. Activating the Receiving Mode via Pin POLLING/_ON

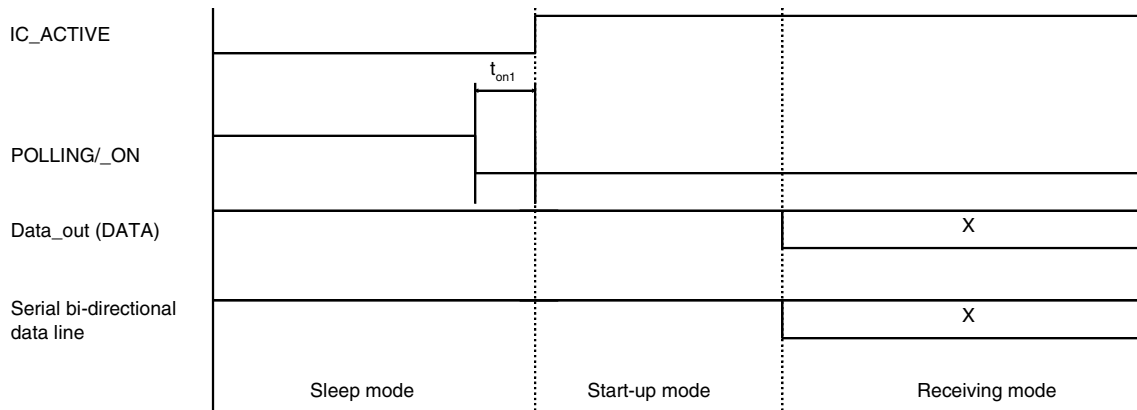

Figure 8-11 on page 16 illustrates how to set the receiver back to polling mode via pin POLLING/_ON. The pin POLLING/_ON must be held to low for the time period t_{on2} . After the positive edge on pin POLLING/_ON and the delay t_{on3} , the polling mode is active and the sleep time T_{Sleep} elapses.

This command is faster than using pin DATA at the cost of an additional connection to the microcontroller.

Figure 8-12 on page 17 illustrates how to set the receiver to receiving mode via the pin POLLING/_ON. The pin POLLING/_ON must be held to Low. After the delay t_{on1} , the receiver changes from sleep mode to start-up mode regardless the programmed values for T_{Sleep} and $N_{Bit-check}$. As long as POLLING/_ON is held to Low, the values for T_{Sleep} and $N_{Bit-check}$ will be ignored, but not deleted (see section “Digital Noise Suppression” on page 21).

If the receiver is polled exclusively by a microcontroller, T_{Sleep} must be programmed to 31 (permanent sleep mode). In this case the receiver remains in sleep mode as long as POLLING/_ON is held to High.

9. Data Clock

The pin DATA_CLK makes a data shift clock available to sample the data stream into a shift register. Using this data clock, a microcontroller can easily synchronize the data stream. This clock can only be used for Manchester and Bi-phase coded signals.

9.1 Generation of the Data Clock

After a successful bit check, the receiver switches from polling mode to receiving mode and the data stream is available at pin DATA. In receiving mode, the data clock control logic (Manchester/Bi-phase demodulator) is active and examines the incoming data stream. This is done, like in the bit check, by subsequent time frame checks where the distance between two edges is continuously compared to a programmable time window. As illustrated in [Figure 9-1 on page 19](#), only two distances between two edges in Manchester and Bi-phase coded signals are valid (T and 2T).

The limits for T are the same as used for the bit check. They can be programmed in the LIMIT-register (Lim_min and Lim_max, see [Table 11-10 on page 26](#) and [Table 11-11 on page 26](#)).

The limits for 2T are calculated as follows:

$$\text{Lower limit of } 2T: \quad \text{Lim_min_}2T = (\text{Lim_min} + \text{Lim_max}) - (\text{Lim_max} - \text{Lim_min})/2$$

$$\text{Upper limit of } 2T: \quad \text{Lim_max_}2T = (\text{Lim_min} + \text{Lim_max}) + (\text{Lim_max} - \text{Lim_min})/2$$

(If the result for 'Lim_min_2T' or 'Lim_max_2T' is not an integer value, it will be round up)

The data clock is available, after the data clock control logic has detected the distance 2T (Start bit) and is issued with the delay t_{delay} after the edge on pin DATA (see [Figure 9-1 on page 19](#)).

If the data clock control logic detects a timing or logical error (Manchester code violation), like illustrated in [Figure 9-2 on page 19](#) and [Figure 9-3 on page 19](#), it stops the output of the data clock. The receiver remains in receiving mode and starts with the bit check. If the bit check was successful and the start bit has been detected, the data clock control logic starts again with the generation of the data clock (see [Figure 9-4 on page 20](#)).

It is recommended to use the function of the data clock only in conjunction with the bit check 3, 6 or 9. If the bit check is set to 0 or the receiver is set to receiving mode via the pin POLLING/_ON, the data clock is available if the data clock control logic has detected the distance 2T (Start bit).

Note that for Bi-phase-coded signals, the data clock is issued at the end of the bit.

Figure 9-1. Timing Diagram of the Data Clock

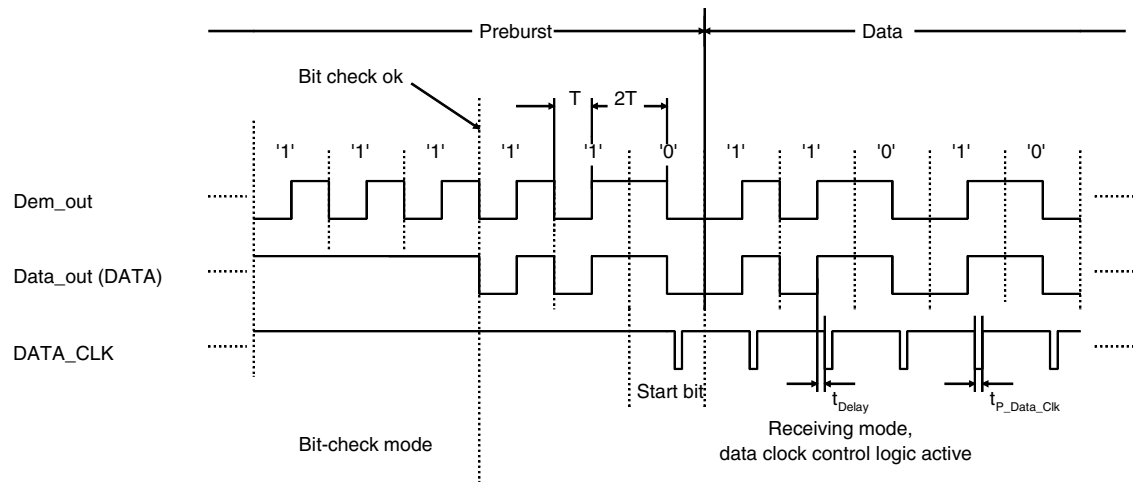

Figure 9-2. Data Clock Disappears Because of a Timing Error

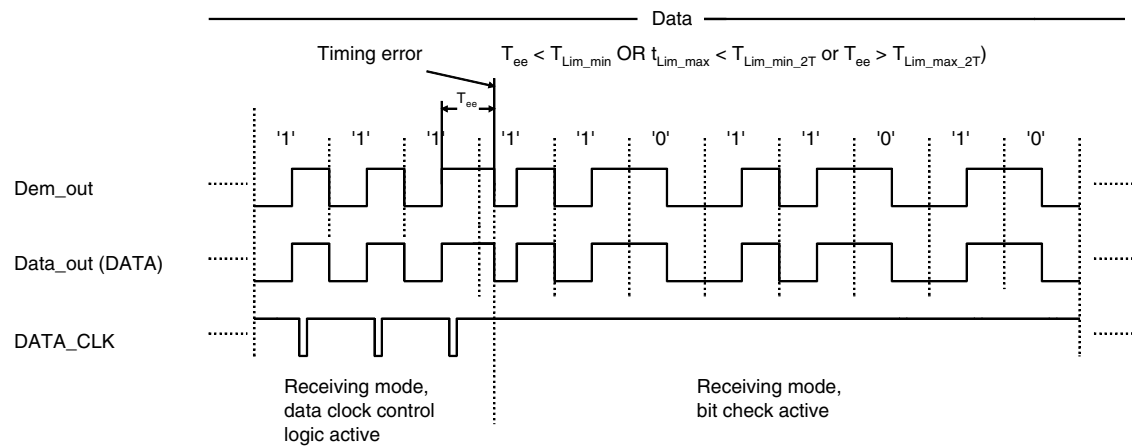

Figure 9-3. Data Clock Disappears Because of a Logical Error

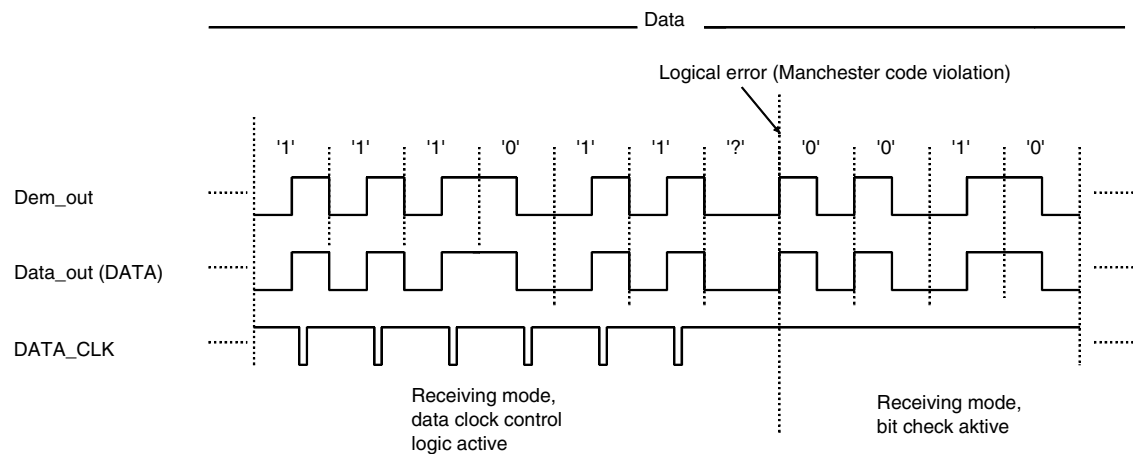
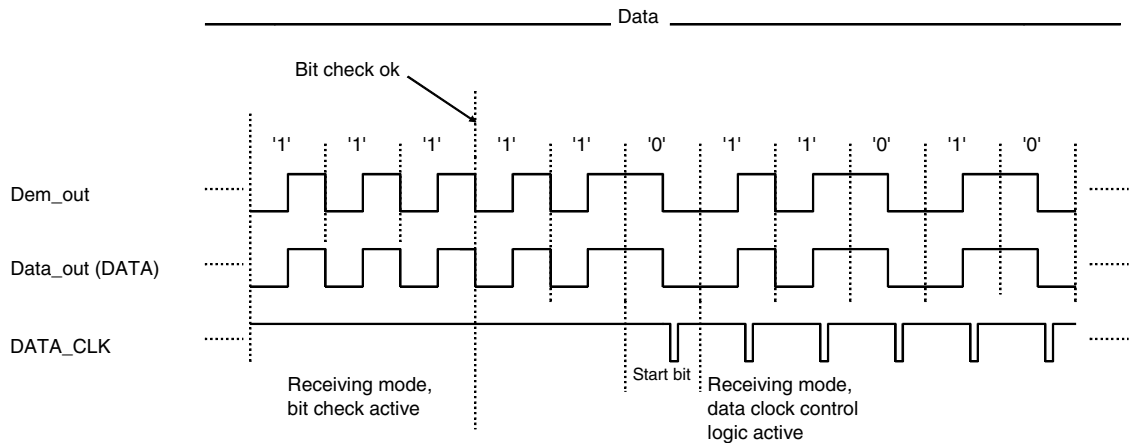

Figure 9-4. Output of the Data Clock After a Successful Bit Check



The delay of the data clock is calculated as follows: $t_{\text{Delay}} = t_{\text{Delay1}} + t_{\text{Delay2}}$

t_{Delay1} is the delay between the internal signals Data_Out and Data_In. For the rising edge, t_{Delay1} depends on the capacitive load C_L at pin DATA and the external pull-up resistor R_{pup} . For the falling edge, t_{Delay1} depends additionally on the external voltage V_X (see [Figure 9-5](#), [Figure 9-6 on page 21](#) and [Figure 13-2 on page 28](#)). When the level of Data_In is equal to the level of Data_Out, the data clock is issued after an additional delay t_{Delay2} .

Note that the capacitive load at pin DATA is limited. If the maximum tolerated capacitive load at pin DATA is exceeded, the data clock disappears (see section [“Data Interface” on page 29](#)).

Figure 9-5. Timing Characteristic of the Data Clock (Rising Edge on Pin DATA)

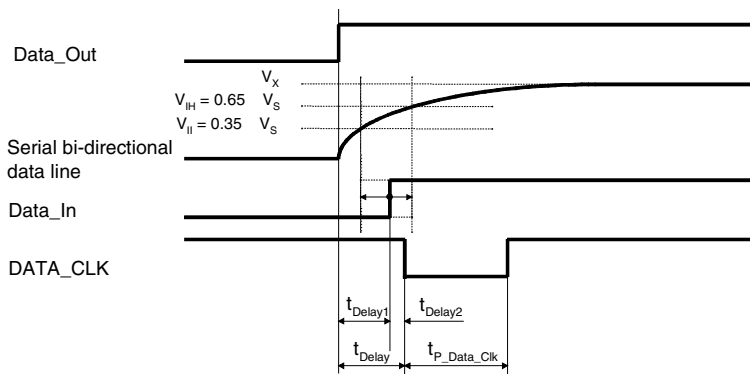
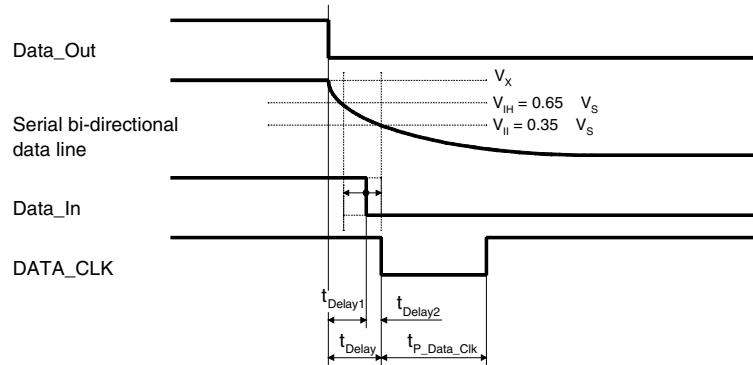

Figure 9-6. Timing Characteristic of the Data Clock (Falling Edge of the Pin DATA)



10. Digital Noise Suppression

After a data transmission, digital noise appears on the data output (see [Figure 10-1 on page 21](#)). Preventing that digital noise keeps the connected microcontroller busy. It can be suppressed in two different ways.

10.1 Automatic Noise Suppression

If the bit Noise_Disable ([Table 11-9 on page 25](#)) in the OPMODE register is set to 1 (default), the receiver changes to bit-check mode at the end of a valid data stream. The digital noise is suppressed and the level at pin DATA is High in that case. The receiver changes back to receiving mode, if the bit check was successful.

This way to suppress the noise is recommended if the data stream is Manchester or Bi-phase coded and is active after power on.

[Figure 10-3 on page 22](#) illustrates the behavior of the data output at the end of a data stream. Note that if the last period of the data stream is a high period (rising edge to falling edge), a pulse occurs on pin DATA. The length of the pulse depends on the selected baud-rate range.

Figure 10-1. Output of Digital Noise at the End of the Data Stream

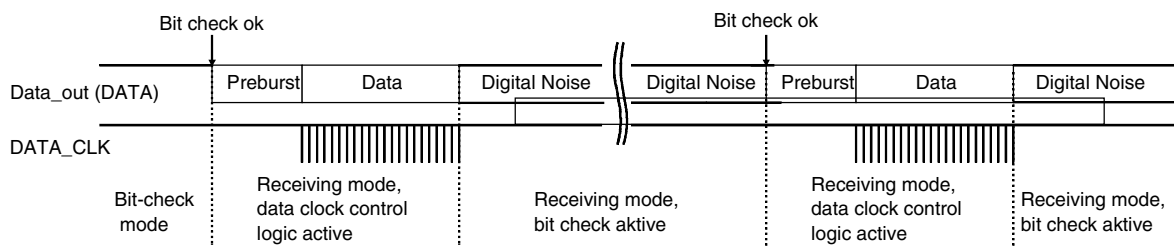

Figure 10-2. Automatic Noise Suppression

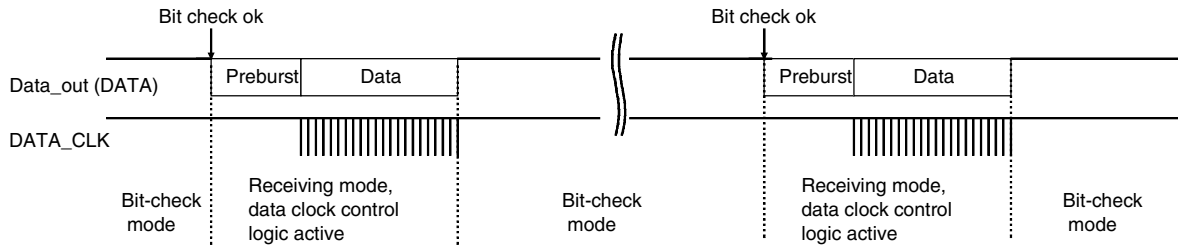
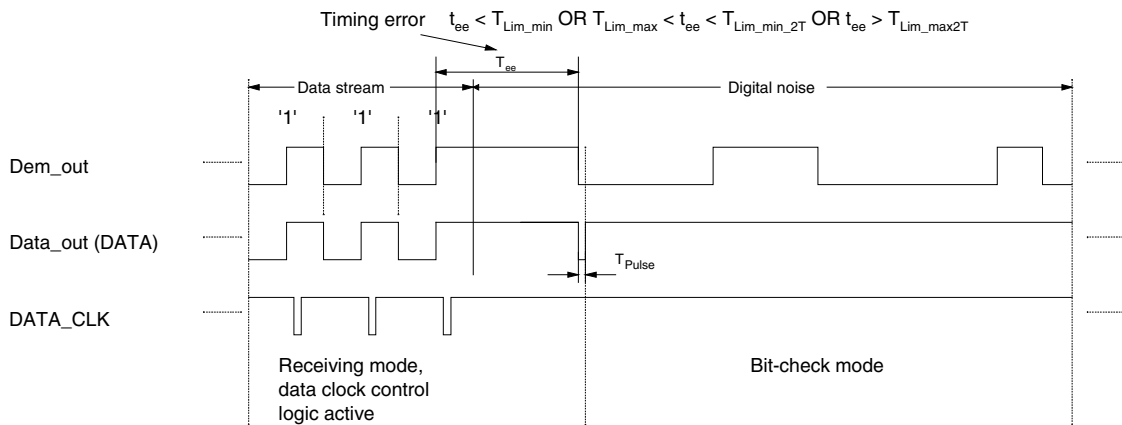

Figure 10-3. Occurrence of a Pulse at the End of the Data Stream



10.2 Controlled Noise Suppression by the Microcontroller

If the bit `Noise_Disable` (see [Table 11-9 on page 25](#)) in the `OPMODE` register is set to 0, digital noise appears at the end of a valid data stream. To suppress the noise, the pin `POLLING/_ON` must be set to Low. The receiver remains in receiving mode. Then, the OFF command causes the change to the start-up mode. The programmed sleep time (see [Table 11-7 on page 25](#)) will not be executed because the level at pin `POLLING/_ON` is low, but the bit check is active in that case. The OFF command activates the bit check also if the pin `POLLING/_ON` is held to Low. The receiver changes back to receiving mode if the bit check was successful. To activate the polling mode at the end of the data transmission, the pin `POLLING/_ON` must be set to High. This way of suppressing the noise is recommended if the data stream is not Manchester or Bi-phase coded.

Figure 10-4. Controlled Noise Suppression

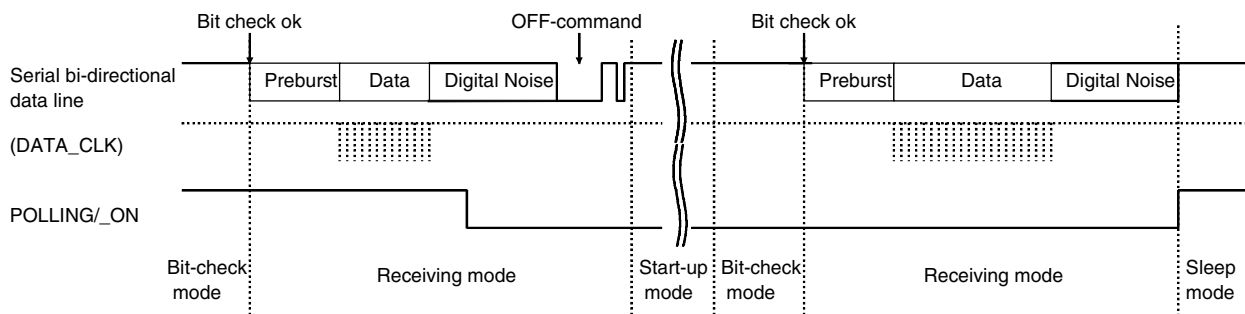

11. Configuration of the Receiver

The T5760/T5761 receiver is configured via two 12-bit RAM registers called OPMODE and LIMIT. The registers can be programmed by means of the bidirectional DATA port. If the register contents have changed due to a voltage drop, this condition is indicated by a certain output pattern called reset marker (RM). The receiver must be reprogrammed in that case. After a Power-On Reset (POR), the registers are set to default mode. If the receiver is operated in default mode, there is no need to program the registers. Table 11-3 on page 23 shows the structure of the registers. According to Table 11-2, bit 1 defines if the receiver is set back to polling mode via the OFF command (see section “Receiving Mode” on page 14) or if it is programmed. Bit 2 represents the register address. It selects the appropriate register to be programmed. To get a high programming reliability, bit 15 (Stop bit), at the end of the programming operation, must be set to 0.

Table 11-1. Effect of Bit 1 and Bit 2 on Programming the Registers

Bit 1	Bit 2	Action
1	x	The receiver is set back to polling mode (OFF command)
0	1	The OPMODE register is programmed
0	0	The LIMIT register is programmed

Table 11-2. Effect of Bit 15 on Programming the Register

Bit 15	Action
0	The values will be written into the register (OPMODE or LIMIT)
1	The values will not be written into the register

Table 11-3. Effect of the Configuration Words within the Registers

Bit 1	Bit 2	Bit 3	Bit 4	Bit 5	Bit 6	Bit 7	Bit 8	Bit 9	Bit 10	Bit 11	Bit 12	Bit 13	Bit 14	Bit 15	
OFF command															
1	-	-	-	-	-	-	-	-	-	-	-	-	-	-	
OPMODE register														-	
0	1	BR_Range		N _{Bit-check}		Modulation	Sleep					X _{Sleep}	Noise Suppression	0	
		Baud1	Baud0	BitChk1	BitChk0	ASK/_FSK	Sleep4	Sleep3	Sleep2	Sleep1	Sleep0	X _{SleepStd}	Noise_Disable		
Default values of Bit 3...14		0	0	0	1	0	0	0	1	1	0	0	1	-	
LIMIT register														-	
0	0	Lim_min					Lim_max								-
		Lim_min5	Lim_min4	Lim_min3	Lim_min2	Lim_min1	Lim_min0	Lim_max5	Lim_max4	Lim_max3	Lim_max2	Lim_max1	Lim_max0	0	
Default values of Bit 3...14		0	1	0	1	0	1	1	0	1	0	0	1	-	



The following tables illustrate the effect of the individual configuration words. The default configuration is highlighted for each word.

BR_Range sets the appropriate baud-rate range and simultaneously defines XLim. XLim is used to define the bit-check limits T_{Lim_min} and T_{Lim_max} as shown in [Table 11-10 on page 26](#) and [Table 11-11 on page 26](#).

Table 11-4. Effect of the configuration word BR_Range

BR_Range		Baud-rate Range/Extension Factor for Bit-check Limits (XLim)
Baud1	Baud0	
0	0	BR_Range0 (application USA/Europe: BR_Range0 = 1.0 kBaud to 1.8 kBaud) XLim = 8 (default)
0	1	BR_Range1 (application USA/Europe: BR_Range1 = 1.8 kBaud to 3.2 kBaud) XLim = 4
1	0	BR_Range2 (application USA/Europe: BR_Range2 = 3.2 kBaud to 5.6 kBaud) XLim = 2
1	1	BR_Range3 (Application USA/Europe: BR_Range3 = 5.6 kBaud to 10 kBaud) XLim = 1

Table 11-5. Effect of the Configuration word $N_{Bit-check}$

$N_{Bit-check}$		Number of Bits to be Checked
BitChk1	BitChk0	
0	0	0
0	1	3 (default)
1	0	6
1	1	9

Table 11-6. Effect of the Configuration Bit Modulation

Modulation	Selected Modulation
ASK/_FSK	–
0	FSK (default)
1	ASK

Table 11-7. Effect of the Configuration Word Sleep

Sleep					Start Value for Sleep Counter ($T_{\text{Sleep}} = \text{Sleep} \times X_{\text{Sleep}} \times 1024 \times T_{\text{Clk}}$)
Sleep4	Sleep3	Sleep2	Sleep1	Sleep0	
0	0	0	0	0	0 (Receiver is continuously polling until a valid signal occurs)
0	0	0	0	1	1 ($T_{\text{Sleep}} \approx 2.1 \text{ ms}$ for $X_{\text{Sleep}} = 1$ and $f_{\text{RF}} = 868.3 \text{ MHz}$, $\approx 2.0 \text{ ms}$ for $f_{\text{RF}} = 915 \text{ MHz}$)
0	0	0	1	0	2
0	0	0	1	1	3
...
0	0	1	1	0	6 ($T_{\text{Sleep}} = 12.695 \text{ ms}$ for $f_{\text{RF}} = 868.3 \text{ MHz}$, 12.047 ms for $f_{\text{RF}} = 915 \text{ MHz}$) (default)
...
1	1	1	0	1	29
1	1	1	1	0	30
1	1	1	1	1	31 (permanent sleep mode)

Table 11-8. Effect of the Configuration Bit XSleep

X_{Sleep}	Extension Factor for Sleep Time ($T_{\text{Sleep}} = \text{Sleep} \times X_{\text{Sleep}} \times 1024 \times T_{\text{Clk}}$)
X_{SleepStd}	
0	1 (default)
1	8

Table 11-9. Effect of the Configuration Bit Noise Suppression

Noise Suppression	Suppression of the Digital Noise at Pin DATA
Noise_Disable	
0	Noise suppression is inactive
1	Noise suppression is active (default)



Table 11-10. Effect of the Configuration Word Lim_min

Lim_min ⁽¹⁾ (Lim_min < 10 is not Applicable)						Lower Limit Value for Bit Check
Lim_min5	Lim_min4	Lim_min3	Lim_min2	Lim_min1	Lim_min0	($T_{Lim_min} = Lim_min \times XLim \times T_{Clk}$)
0	0	1	0	1	0	10
0	0	1	0	1	1	11
0	0	1	1	0	0	12
..	
0	1	0	1	0	1	21 (default) ($T_{Lim_min} = 347 \mu s$ for $f_{RF} = 868.3$ MHz and BR_Range0 $T_{Lim_min} = 329 \mu s$ for $f_{RF} = 915$ MHz and BR_Range0)
..	
1	1	1	1	0	1	61
1	1	1	1	1	0	62
1	1	1	1	1	1	63

Note: 1. Lim_min is also used to determine the margins of the data clock control logic (see section “Data Clock” on page 18).

Table 11-11. Effect of the Configuration Word Lim_max

Lim_max ⁽¹⁾ (Lim_max < 12 is not applicable)						Upper Limit Value for Bit Check
Lim_max5	Lim_max4	Lim_max3	Lim_max2	Lim_max1	Lim_max0	($TLim_max = (Lim_max - 1) \times XLim \times T_{Clk}$)
0	0	1	1	0	0	12
0	0	1	1	0	1	13
0	0	1	1	1	0	14
..	
1	0	1	0	0	1	41 (default) ($TLim_max = 661 \mu s$ for $f_{RF} = 868.3$ MHz and BR_Range0, $TLim_max = 627 \mu s$ for $f_{RF} = 915$ MHz and BR_Range0)
..	
1	1	1	1	0	1	61
1	1	1	1	1	0	62
1	1	1	1	1	1	63

Note: 1. Lim_max is also used to determine the margins of the data clock control logic (see section “Data Clock” on page 18).

12. Conservation of the Register Information

The ATA5760/ATA5761 implies an integrated power-on reset and brown-out detection circuitry to provide a mechanism to preserve the RAM register information.

According to [Figure 12-1](#), a power-on reset (POR) is generated if the supply voltage V_S drops below the threshold voltage $V_{ThReset}$. The default parameters are programmed into the configuration registers in that condition. Once V_S exceeds $V_{ThReset}$ the POR is canceled after the minimum reset period t_{Rst} . A POR is also generated when the supply voltage of the receiver is turned on.

To indicate that condition, the receiver displays a reset marker (RM) at pin DATA after a reset. The RM is represented by the fixed frequency f_{RM} at a 50% duty-cycle. RM can be canceled via a Low pulse t_1 at pin DATA. The RM implies the following characteristics:

- f_{RM} is lower than the lowest feasible frequency of a data signal. By this means, RM cannot be misinterpreted by the connected microcontroller.
- If the receiver is set back to polling mode via pin DATA, RM cannot be canceled by accident if t_1 is applied according to the proposal in the section [“Programming the Configuration Register”](#) on page 28.

By means of that mechanism the receiver cannot lose its register information without communicating that condition via the reset marker RM.

Figure 12-1. Generation of the Power-on Reset

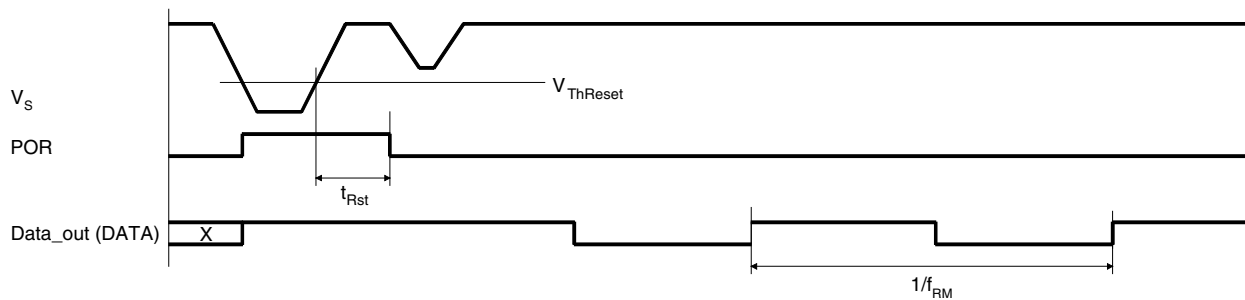

13. Programming the Configuration Register

Figure 13-1. Timing of the Register Programming

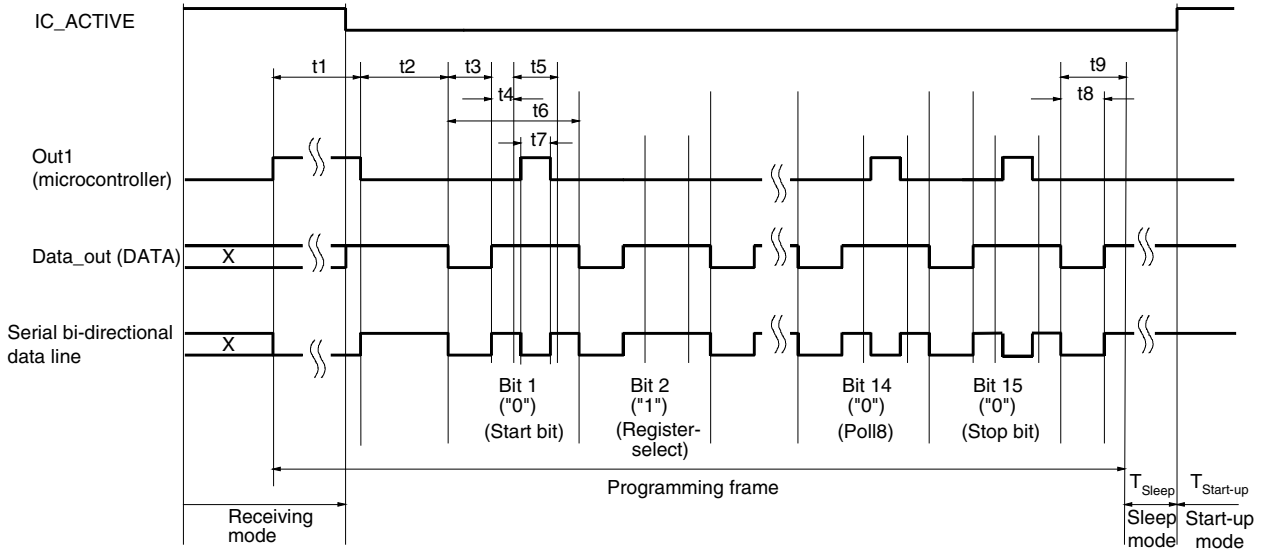
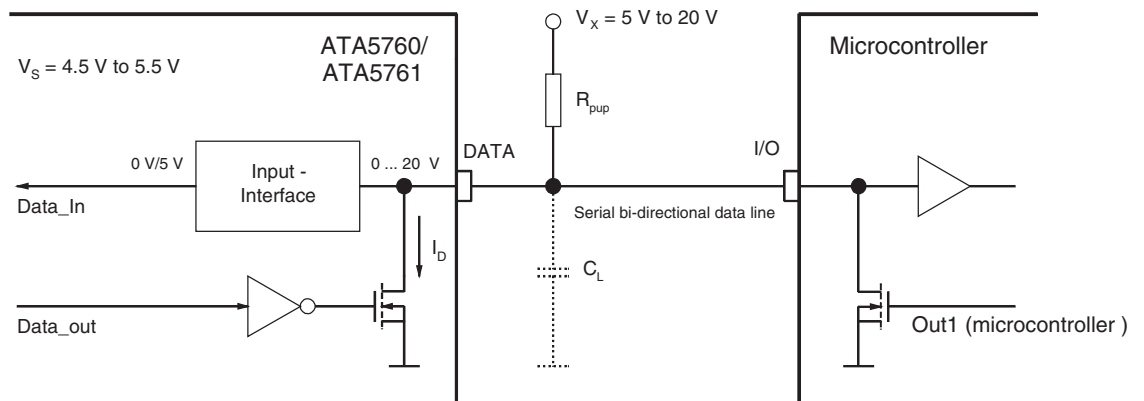

Figure 13-2. Data Interface



The configuration registers are programmed serially via the bi-directional data line according to [Figure 13-1](#) and [Figure 13-2](#).

To start programming, the serial data line DATA is pulled to Low for the time period t_1 by the microcontroller. When DATA has been released, the receiver becomes the master device. When the programming delay period t_2 has elapsed, it emits 15 subsequent synchronization pulses with the pulse length t_3 . After each of these pulses, a programming window occurs. The delay until the program window starts is determined by t_4 , the duration is defined by t_5 . Within the programming window, the individual bits are set. If the microcontroller pulls down pin DATA for the time period t_7 during t_5 , the according bit is set to '0'. If no programming pulse t_7 is issued, this bit is set to '1'. All 15 bits are subsequently programmed this way. The time frame to program a bit is defined by t_6 .

Bit 15 is followed by the equivalent time window t_9 . During this window, the equivalence acknowledge pulse t_8 (E_Ack) occurs if the just programmed mode word is equivalent to the mode word that was already stored in that register. E_Ack should be used to verify that the mode word was correctly transferred to the register. The register must be programmed twice in that case.

Programming of a register is possible both in sleep-mode and in active-mode of the receiver.

During programming, the LNA, LO, lowpass filter IF-amplifier and the FSK/ASK Manchester demodulator are disabled.

The programming start pulse t_1 initiates the programming of the configuration registers. If bit 1 is set to '1', it represents the OFF command to set the receiver back to polling mode at the same time. For the length of the programming start pulse t_1 , the following convention should be considered:

- $t_1(\text{min}) < t_1 < 5632 T_{\text{Clk}}$:
 $t_1(\text{min})$ is the minimum specified value for the relevant BR_Range

Programming respectively OFF command is initiated if the receiver is not in reset mode. If the receiver is in reset mode, programming respectively Off command is not initiated and the reset marker RM is still present at pin DATA.

This period is generally used to switch the receiver to polling mode or to start the programming of a register. In reset condition, RM is not cancelled by accident.

- $t_1 > 7936 \times T_{\text{Clk}}$

Programming respectively OFF command is initiated in any case. The registers OPMODE and LIMIT are set to the default values. RM is cancelled if present.

This period is used if the connected microcontroller detected RM. If the receiver operates in default mode, this time period for t_1 can generally be used.

Note that the capacitive load at pin DATA is limited.

14. Data Interface

The data interface (see [Figure 13-2 on page 28](#)) is designed for automotive requirements. It can be connected via the pull-up resistor R_{pup} up to 20V and is short-circuit-protected.

The applicable pull-up resistor R_{pup} depends on the load capacity C_L at pin DATA and the selected BR_range (see [Table 14-1](#)).

Table 14-1. Applicable R_{pup}

-	BR_range	Applicable R_{pup}
$C_L \leq 1\text{nF}$	B0	1.6 k Ω to 47 k Ω
	B1	1.6 k Ω to 22 k Ω
	B2	1.6 k Ω to 12 k Ω
	B3	1.6 k Ω to 5.6 k Ω
$C_L \leq 100\text{pF}$	B0	1.6 k Ω to 470 k Ω
	B1	1.6 k Ω to 220 k Ω
	B2	1.6 k Ω to 120 k Ω
	B3	1.6 k Ω to 56 k Ω

Figure 14-1. Application Circuit: $f_{RF} = 868.3$ MHz without SAW Filter

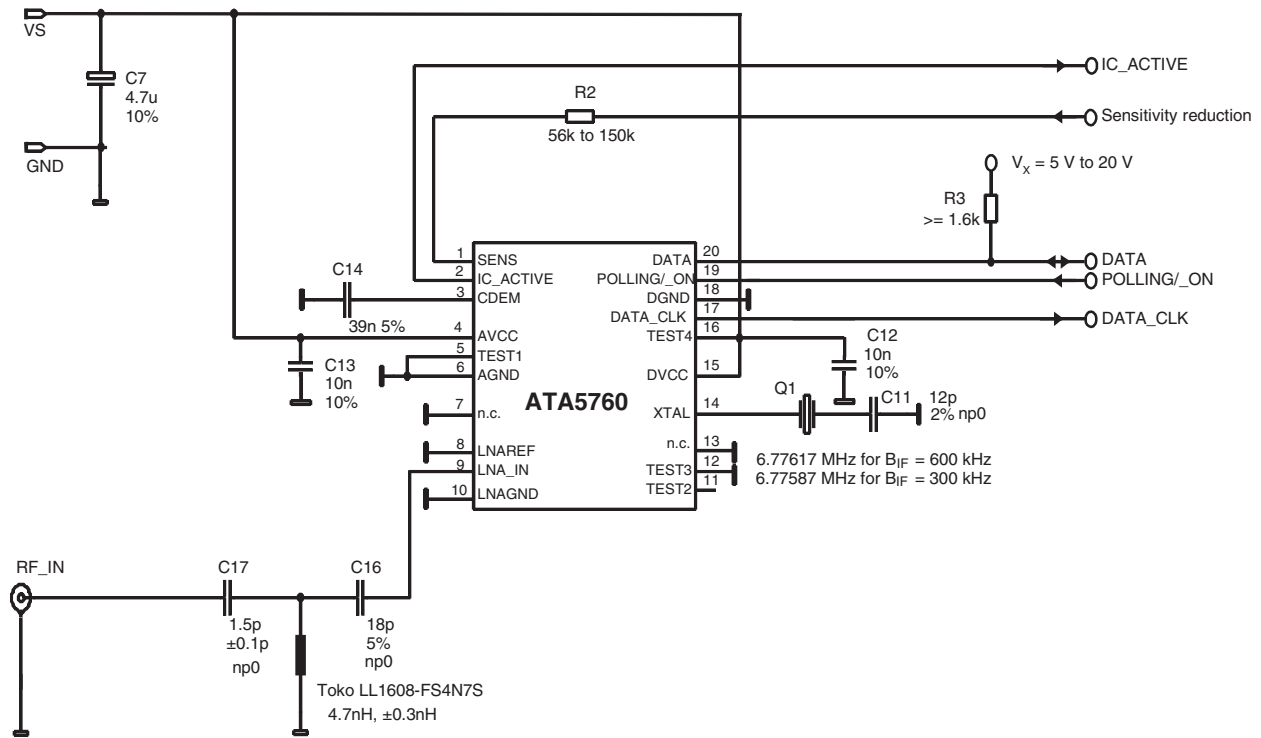
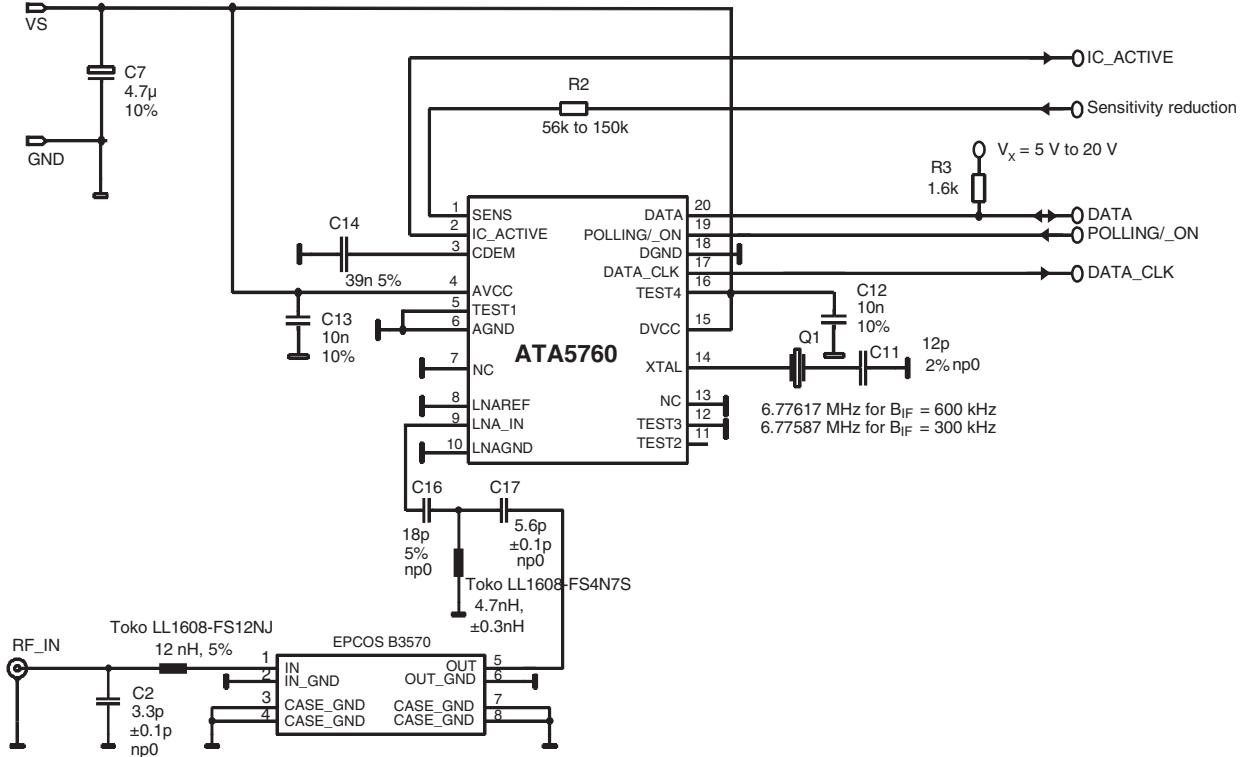

Figure 14-2. Application Circuit: $f_{RF} = 868.3$ MHz with SAW Filter



15. Absolute Maximum Ratings

Stresses beyond those listed under “Absolute Maximum Ratings” may cause permanent damage to the device. This is a stress rating only and functional operation of the device at these or any other conditions beyond those indicated in the operational sections of this specification is not implied. Exposure to absolute maximum rating conditions for extended periods may affect device reliability.

Parameters	Symbol	Min.	Max.	Unit
Supply voltage	V_S		6	V
Power dissipation	P_{tot}		1000	mW
Junction temperature	T_J		150	°C
Storage temperature	T_{stg}	-55	+125	°C
Ambient temperature	T_{amb}	-40	+105	°C
Maximum input level, input matched to 50Ω	$P_{in,max}$		10	dBm

16. Thermal Resistance

Parameters	Symbol	Value	Unit
Junction ambient	R_{thJA}	100	K/W

17. Electrical Characteristics

All parameters refer to GND, $T_{amb} = -40^{\circ}\text{C}$ to $+105^{\circ}\text{C}$, $V_S = 4.5\text{V}$ to 5.5V , $f_0 = 868.3\text{ MHz}$ and $f_0 = 915\text{ MHz}$, unless otherwise specified. (For typical values: $V_S = 5\text{V}$, $T_{amb} = 25^{\circ}\text{C}$)

Parameter	Test Conditions	Symbol	$f_{RF} = 868.3\text{ MHz}$			$f_{RF} = 915\text{ MHz}$			Variable Oscillator			Unit
			Min.	Typ.	Max.	Min.	Typ.	Max.	Min.	Typ.	Max.	
Basic Clock Cycle of the Digital Circuitry												
Basic clock cycle		T_{Clk}	2.0662		2.0662	1.9607		1.9607	$14/f_{XTO}$		$14/f_{XTO}$	μs
Extended basic clock cycle	BR_Range0	T_{XClk}	16.53		16.53	15.69		15.69	$8 \times T_{Clk}$		$8 \times T_{Clk}$	μs
	BR_Range1		8.26		8.26	7.84		7.84	$4 \times T_{Clk}$		$4 \times T_{Clk}$	μs
	BR_Range2		4.13		4.13	3.92		3.92	$2 \times T_{Clk}$		$2 \times T_{Clk}$	μs
	BR_Range3		2.07		2.07	1.96		1.96	$1 \times T_{Clk}$		$1 \times T_{Clk}$	μs
Polling Mode												
Sleep time (see Figure 8-4 on page 13 , Figure 9-1 on page 19 and Figure 14-1 on page 30)	Sleep and XSleep are defined in the OPMODE register	T_{Sleep}	Sleep × $X_{Sleep} \times 1024 \times 2.0662$		Sleep × $X_{Sleep} \times 1024 \times 2.0662$	Sleep × $X_{Sleep} \times 1024 \times 1.9607$		Sleep × $X_{Sleep} \times 1024 \times 1.9607$	Sleep × $X_{Sleep} \times 1024 \times T_{Clk}$		Sleep × $X_{Sleep} \times 1024 \times T_{Clk}$	ms
Start-up time (see Figure 8-4 on page 13 and Figure 8-5 on page 13)	BR_Range0	$T_{Startup}$	1852		1852	1758		1758	896.5		896.5	μs
	BR_Range1		1059		1059	1049		1049	512.5		512.5	μs
	BR_Range2		1059		1059	1049		1049	512.5		512.5	μs
	BR_Range3		662		662	628		628	$320.5 \times T_{Clk}$		$320.5 \times T_{Clk}$	μs



17. Electrical Characteristics (Continued)

All parameters refer to GND, $T_{amb} = -40^{\circ}\text{C}$ to $+105^{\circ}\text{C}$, $V_S = 4.5\text{V}$ to 5.5V , $f_0 = 868.3\text{ MHz}$ and $f_0 = 915\text{ MHz}$, unless otherwise specified.
(For typical values: $V_S = 5\text{V}$, $T_{amb} = 25^{\circ}\text{C}$)

Parameter	Test Conditions	Symbol	$f_{RF} = 868.3\text{ MHz}$			$f_{RF} = 915\text{ MHz}$			Variable Oscillator			Unit	
			Min.	Typ.	Max.	Min.	Typ.	Max.	Min.	Typ.	Max.		
Time for bit check (see Figure 8-4 on page 13)	Average bit-check time while polling, no RF applied (see Figure 8-8 on page 15 and Figure 8-9 on page 15)	$T_{\text{Bit-check}}$											
	BR_Range0		0.45		0.45						ms		
	BR_Range1		0.24		0.24						ms		
	BR_Range2		0.14		0.14						ms		
	BR_Range3		0.08		0.08						ms		
Time for bit check (see Figure 8-4 on page 13)	Bit-check time for a valid input signal f_{Sig} (see Figure 8-5 on page 13)	$T_{\text{Bit-check}}$											
	$N_{\text{Bit-check}} = 0$		$3/f_{\text{Sig}}$		$3/f_{\text{Sig}}$		$3/f_{\text{Sig}}$		$1 \times T_{\text{XClk}}$		$1 \times T_{\text{Clk}}$	ms	
	$N_{\text{Bit-check}} = 3$		$6/f_{\text{Sig}}$		$6/f_{\text{Sig}}$		$6/f_{\text{Sig}}$		$3/f_{\text{Sig}}$		$3.5/f_{\text{Sig}}$	ms	
	$N_{\text{Bit-check}} = 6$		$9/f_{\text{Sig}}$		$9/f_{\text{Sig}}$		$9/f_{\text{Sig}}$		$6/f_{\text{Sig}}$		$6.5/f_{\text{Sig}}$	ms	
	$N_{\text{Bit-check}} = 9$								$9/f_{\text{Sig}}$		$9.5/f_{\text{Sig}}$	ms	
Receiving Mode													
Intermediate frequency		f_{IF}		0.95			1.00		$f_{\text{RF}}/915$			MHz	
Baud-rate range	BR_Range0	BR_Range	1.0		1.8	1.054		1.89	$\text{BR_Range0} \times 2 \mu\text{s}/T_{\text{Clk}}$			kBaud	
	BR_Range1		1.8		3.2	1.89		3.38	$\text{BR_Range1} \times 2 \mu\text{s}/T_{\text{Clk}}$			kBaud	
	BR_Range2		3.2		5.6	3.38		5.9	$\text{BR_Range2} \times 2 \mu\text{s}/T_{\text{Clk}}$			kBaud	
	BR_Range3		5.6		10.0	5.9		10.5	$\text{BR_Range3} \times 2 \mu\text{s}/T_{\text{Clk}}$			kBaud	
Minimum time period between edges at pin DATA (see Figure 8-11 and Figure 8-12 on page 17) (With the exception of parameter T_{Pulse})	BR_Range =	$t_{\text{DATA_min}}$											
	BR_Range0		165.3		165.3	156.8		156.8	$10 \times T_{\text{XClk}}$		$10 \times T_{\text{XClk}}$	μs	
	BR_Range1		82.6		82.6	78.4		78.4	$10 \times T_{\text{XClk}}$		$10 \times T_{\text{XClk}}$	μs	
	BR_Range2		41.3		41.3	39.2		39.2	$10 \times T_{\text{XClk}}$		$10 \times T_{\text{XClk}}$	μs	
	BR_Range3		20.7		20.7	19.6		19.6	$10 \times T_{\text{XClk}}$		$10 \times T_{\text{XClk}}$	μs	
Maximum Low period at pin DATA (see Figure 8-9 on page 15)	BR_Range =	$t_{\text{DATA_L_max}}$											
	BR_Range0		2149		2149	2139		2139	$130 \times T_{\text{XClk}}$		$130 \times T_{\text{XClk}}$	μs	
	BR_Range1		1074		1074	1020		1020	$130 \times T_{\text{XClk}}$		$130 \times T_{\text{XClk}}$	μs	
	BR_Range2		537		537	510		510	$130 \times T_{\text{XClk}}$		$130 \times T_{\text{XClk}}$	μs	
BR_Range3	269		269	255		255	$130 \times T_{\text{XClk}}$		$130 \times T_{\text{XClk}}$	μs			
Delay to activate the start-up mode (see Figure 9-3 on page 19)		Ton1	19.6		21.7		18.6		20.6	$9.5 \times T_{\text{Clk}}$		$10.5 \times T_{\text{Clk}}$	μs

17. Electrical Characteristics (Continued)

All parameters refer to GND, $T_{amb} = -40^{\circ}\text{C}$ to $+105^{\circ}\text{C}$, $V_S = 4.5\text{V}$ to 5.5V , $f_0 = 868.3\text{ MHz}$ and $f_0 = 915\text{ MHz}$, unless otherwise specified. (For typical values: $V_S = 5\text{V}$, $T_{amb} = 25^{\circ}\text{C}$)

Parameter	Test Conditions	Symbol	$f_{RF} = 868.3\text{ MHz}$			$f_{RF} = 915\text{ MHz}$			Variable Oscillator			Unit
			Min.	Typ.	Max.	Min.	Typ.	Max.	Min.	Typ.	Max.	
OFF command at pin POLLING/_ON (see Figure 9-2 on page 19)		Ton2	16.5			15.6			$8 \times T_{Clk}$			μs
Delay to activate the sleep mode (see Figure 9-2 on page 19)		Ton3	17.6		19.6	16.6		18.6	$8.5 \times T_{Clk}$		$9.5 \times T_{Clk}$	μs
Pulse on pin DATA at the end of a data stream (see Figure 12-1 on page 27)	BR_Range = BR_Range0 BR_Range1 BR_Range2 BR_Range3	T_{Pulse}	16.5		16.5	15.69		15.69	$8 \times T_{Clk}$		$8 \times T_{Clk}$	μs
			8.3		8.3	7.84		7.84	$4 \times T_{Clk}$		$4 \times T_{Clk}$	μs
			4.1		4.1	3.92		3.92	$2 \times T_{Clk}$		$2 \times T_{Clk}$	μs
			2.1		2.1	1.96		1.96	$1 \times T_{Clk}$		$1 \times T_{Clk}$	μs
Configuration of the Receiver (see Figure 8-10 on page 16 and Figure 14-1 on page 30)												
Frequency of the reset marker	Frequency is stable within 50 ms after POR	f_{RM}	118.2		118.2	124.5		124.5	$1/(4096 \times T_{Clk})$		$1/(4096 \times T_{Clk})$	Hz
Programming start pulse	BR_Range = BR_Range0 BR_Range1 BR_Range2 BR_Range3 after POR	t1	3355		11637	3184		11043	$1624 \times T_{Clk}$		$5632 \times T_{Clk}$	μs
			2273		11637	2168		11043	$1100 \times T_{Clk}$		$5632 \times T_{Clk}$	μs
			1731		11637	1643		11043	$838 \times T_{Clk}$		$5632 \times T_{Clk}$	μs
			1461		11637	1386		11043	$707 \times T_{Clk}$		$5632 \times T_{Clk}$	μs
			16397			15560			$7936 \times T_{Clk}$			μs
Programming delay period		t2	795		797	754		756	$384.5 \times T_{Clk}$		$385.5 \times T_{Clk}$	μs
Synchronization pulse		t3	264		264	251		251	$128 \times T_{Clk}$		$128 \times T_{Clk}$	μs
Delay until of the program window starts		t4	131		131	125		125	$63.5 \times T_{Clk}$		$63.5 \times T_{Clk}$	μs
Programming window		t5	529		529	502		502	$256 \times T_{Clk}$		$256 \times T_{Clk}$	μs
Time frame of a bit		t6	1058		1058	1004		1004	$512 \times T_{Clk}$		$512 \times T_{Clk}$	μs
Programming pulse		t7	132		529	125		502	$64 \times T_{Clk}$		$256 \times T_{Clk}$	μs
Equivalent acknowledge pulse: E_Ack		t8	264		264	251		251	$128 \times T_{Clk}$		$128 \times T_{Clk}$	μs
Equivalent time window		t9	533		533	506		506	$258 \times T_{Clk}$		$258 \times T_{Clk}$	μs
OFF-bit programming window		t10	929		929	881		881	$449.5 \times T_{Clk}$		$449.5 \times T_{Clk}$	μs

17. Electrical Characteristics (Continued)

All parameters refer to GND, $T_{amb} = -40^{\circ}\text{C}$ to $+105^{\circ}\text{C}$, $V_S = 4.5\text{V}$ to 5.5V , $f_0 = 868.3\text{ MHz}$ and $f_0 = 915\text{ MHz}$, unless otherwise specified.
(For typical values: $V_S = 5\text{V}$, $T_{amb} = 25^{\circ}\text{C}$)

Parameter	Test Conditions	Symbol	$f_{RF} = 868.3\text{ MHz}$			$f_{RF} = 915\text{ MHz}$			Variable Oscillator			Unit
			Min.	Typ.	Max.	Min.	Typ.	Max.	Min.	Typ.	Max.	
Data Clock (see Figure 10-2 on page 22 and Figure 10-3 on page 22)												
Minimum delay time between edge at DATA and DATA_CLK	BR_Range = BR_Range0	t_{Delay2}	0		16.5	0		16.7	0		$1 \times T_{XClk}$	μs
	BR_Range1		0		8.3	0		7.8	0		$1 \times T_{XClk}$	μs
	BR_Range2		0		4.1	0		3.9	0		$1 \times T_{XClk}$	μs
	BR_Range3		0		2.1	0		1.96	0		$1 \times T_{XClk}$	μs
Pulse width of negative pulse at pin DATA_CLK	BR_Range = BR_Range0	$t_{P_DATA_CLK}$	66.1		66.1	63		63	$4 \times T_{XClk}$		$4 \times T_{XClk}$	μs
	BR_Range1		33.0		33.0	31		31	$4 \times T_{XClk}$		$4 \times T_{XClk}$	μs
	BR_Range2		16.5		16.5	15.7		15.7	$4 \times T_{XClk}$		$4 \times T_{XClk}$	μs
	BR_Range3		8.3		8.3	7.8		7.8	$4 \times T_{XClk}$		$4 \times T_{XClk}$	μs

18. Electrical Characteristics (continued)

All parameters refer to GND, $T_{amb} = -40^{\circ}\text{C}$ to $+105^{\circ}\text{C}$, $V_S = 4.5\text{V}$ to 5.5V , $f_0 = 868.3\text{ MHz}$ and $f_0 = 915\text{ MHz}$, unless otherwise specified.
(For typical values: $V_S = 5\text{V}$, $T_{amb} = 25^{\circ}\text{C}$)

Parameters	Test Conditions	Symbol	Min.	Typ.	Max.	Unit
Current consumption	Sleep mode (XTO and polling logic active)	I_{Soff}		170	276	μA
	IC active (start-up-, bit-check-, receiving mode) Pin DATA = H FSK ASK	I_{Son}		7.8 7.4	9.9 9.6	mA mA
LNA, Mixer, Polyphase Lowpass and IF Amplifier (Input Matched According to Figure 14-1 on page 30 Referred to RFIN)						
Third-order intercept point	LNA/mixer/IF amplifier	IIP3		-16		dBm
LO spurious emission	Required according to I-ETS 300220	$I_{S_{LORF}}$		-70	-57	dBm
System noise figure	With power matching $I_{S11} < -10\text{ dB}$	NF		5		dB
LNA_IN input impedance	At 868.3 MHz At 915 MHz	$Z_{i_{LNA_IN}}$		200 3.2 200 3.2		Ω pF Ω pF
1 dB compression point		$IP_{1\text{dB}}$		-25		dBm
Image rejection	Within the complete image band		20	30		dB
Maximum input level	$BER \leq 10^{-3}$, FSK mode	P_{in_max}			-10	dBm
	ASK mode				-10	dBm

18. Electrical Characteristics (continued)

All parameters refer to GND, $T_{amb} = -40^{\circ}\text{C}$ to $+105^{\circ}\text{C}$, $V_S = 4.5\text{V}$ to 5.5V , $f_0 = 868.3\text{ MHz}$ and $f_0 = 915\text{ MHz}$, unless otherwise specified. (For typical values: $V_S = 5\text{V}$, $T_{amb} = 25^{\circ}\text{C}$)

Parameters	Test Conditions	Symbol	Min.	Typ.	Max.	Unit
Local Oscillator						
Operating frequency range VCO	T5760	f_{VCO}	866		871	MHz
	T5761	f_{VCO}	900		929	MHz
Phase noise local oscillator	$f_{osc} = 867.3\text{ MHz}$ at 10 MHz	L (fm)		-140	-130	dBc/Hz
Spurious of the VCO	At $\pm f_{XTO}$			-55	-45	dBc
XTO pulling	XTO pulling, appropriate load capacitance must be connected to XTAL, crystal $C_M = 7\text{ fF}$	f_{XTO}	-30ppm	f_{XTAL}	+30ppm	MHz
Series resonance resistor of the crystal	Parameter of the supplied crystal	R_S			120	Ω
Static capacitance at pin XTAL to GND	Parameter of the supplied crystal and board parasitics	C_0			6.5	pF
Analog Signal Processing (Input Matched According to Figure 14-1 on page 30 Referred to RFIN)						
Input sensitivity ASK	ASK (level of carrier) 300 kHz IF-filter BER $\leq 10^{-3}$, 100% Mod $f_{in} = 868.3\text{ MHz}/915\text{ MHz}$ $V_S = 5\text{V}$, $T_{amb} = 25^{\circ}\text{C}$ $f_{IF} = 950\text{ kHz}/1\text{ MHz}$	P_{Ref_ASK}				
	BR_Range0		-111	-113	-115	dBm
	BR_Range1		-109	-111	-113	dBm
	BR_Range2		-108	-110	-112	dBm
	BR_Range3		-106	-108	-110	dBm
Input sensitivity ASK	ASK (level of carrier) 600 kHz IF-filter BER $\leq 10^{-3}$, 100% Mod $f_{in} = 868.3\text{ MHz}/915\text{ MHz}$ $V_S = 5\text{V}$, $T_{amb} = 25^{\circ}\text{C}$ $f_{IF} = 950\text{ kHz}/1\text{ MHz}$	P_{Ref_ASK}				
	BR_Range0		-110	-112	-114	dBm
	BR_Range1		-108.5	-110.5	-112.5	dBm
	BR_Range2		-108	-110	-112	dBm
	BR_Range3		-106	-108	-110	dBm
Sensitivity variation ASK for the full operating range compared to $T_{amb} = 25^{\circ}\text{C}$, $V_S = 5\text{V}$	$f_{in} = 868.3\text{ MHz}/915\text{ MHz}$ $f_{IF} = 950\text{ kHz}/989\text{ kHz}/1\text{ MHz}$ $P_{ASK} = P_{Ref_ASK} + \Delta P_{Ref}$	ΔP_{Ref}	+2.5		-1.0	dB

18. Electrical Characteristics (continued)

All parameters refer to GND, $T_{amb} = -40^{\circ}\text{C}$ to $+105^{\circ}\text{C}$, $V_S = 4.5\text{V}$ to 5.5V , $f_0 = 868.3\text{ MHz}$ and $f_0 = 915\text{ MHz}$, unless otherwise specified.
(For typical values: $V_S = 5\text{V}$, $T_{amb} = 25^{\circ}\text{C}$)

Parameters	Test Conditions	Symbol	Min.	Typ.	Max.	Unit
Sensitivity variation ASK for full operating range including IF filter compared to $T_{amb} = 25^{\circ}\text{C}$, $V_S = 5\text{V}$	300 kHz version $f_{in} = 868.3\text{ MHz}/915\text{ MHz}$ $f_{IF} = 950\text{ kHz}/989\text{ kHz}/1\text{ MHz}$ $f_{IF} -110\text{ kHz}$ to $+110\text{ kHz}$ $f_{IF} -140\text{ kHz}$ to $+140\text{ kHz}$ $P_{ASK} = P_{Ref_ASK} + \Delta P_{Ref}$	ΔP_{Ref}	+5.5 +7.5		-1.5 -1.5	dB dB
	600 kHz version $f_{in} = 868.3\text{ MHz}/915\text{ MHz}$ $f_{IF} = 950\text{ kHz}/989\text{ kHz}/1\text{ MHz}$ $f_{IF} -210\text{ kHz}$ to $+210\text{ kHz}$ $f_{IF} -270\text{ kHz}$ to $+270\text{ kHz}$ $P_{ASK} = P_{Ref_ASK} + \Delta P_{Ref}$	ΔP_{Ref}	+5.5 +7.5		-1.5 -1.5	dB dB
Input sensitivity FSK 300 kHz and 600 kHz version	$BER \leq 10^{-3}$ $f_{in} = 868.3\text{ MHz}/915\text{ MHz}$ $V_S = 5\text{V}$, $T_{amb} = 25^{\circ}\text{C}$ $f_{IF} = 950\text{ kHz}/989\text{ kHz}/1\text{ MHz}$					
	BR_Range0 $df = \pm 16\text{ kHz}$ to $\pm 28\text{ kHz}$ $df = \pm 10\text{ kHz}$ to $\pm 100\text{ kHz}$	P_{Ref_FSK}	-103 -101	-106	-107.5 -107.5	dBm dBm
	BR_Range1 $df = \pm 16\text{ kHz}$ to $\pm 28\text{ kHz}$ $df = \pm 10\text{ kHz}$ to $\pm 100\text{ kHz}$	P_{Ref_FSK}	-101 -99	-104	-105.5 -105.5	dBm dBm
	BR_Range2 $df = \pm 18\text{ kHz}$ to $\pm 31\text{ kHz}$ $df = \pm 13\text{ kHz}$ to $\pm 100\text{ kHz}$	P_{Ref_FSK}	-99.5 -97.5	-102.5	-104	dBm dBm
	BR_Range3 $df = \pm 25\text{ kHz}$ to $\pm 44\text{ kHz}$ $df = \pm 20\text{ kHz}$ to $\pm 100\text{ kHz}$	P_{Ref_FSK}	-97.5 -95.5	-100.5	-102	dBm dBm
Sensitivity variation FSK for the full operating range compared to $T_{amb} = 25^{\circ}\text{C}$, $V_S = 5\text{V}$	$f_{in} = 868.3\text{ MHz}/915\text{ MHz}$ $f_{IF} = 950\text{ kHz}/989\text{ kHz}/1\text{ MHz}$ $P_{FSK} = P_{Ref_FSK} + \Delta P_{Ref}$	ΔP_{Ref}	+3		-1.5	dB
Sensitivity variation FSK for the full operating range including IF filter compared to $T_{amb} = 25^{\circ}\text{C}$, $V_S = 5\text{V}$	300 kHz version $f_{in} = 868.3\text{ MHz}/915\text{ MHz}$ $f_{IF} = 950\text{ kHz}/989\text{ kHz}/1\text{ MHz}$ $f_{IF} -110\text{ kHz}$ to $+110\text{ kHz}$ $f_{IF} -140\text{ kHz}$ to $+140\text{ kHz}$ $f_{IF} -180\text{ kHz}$ to $+180\text{ kHz}$ $P_{FSK} = P_{Ref_FSK} + \Delta P_{Ref}$	ΔP_{Ref}	+6 +8 +11		-2 -2 -2	dB dB dB
	600 kHz version $f_{in} = 868.3\text{ MHz}/915\text{ MHz}$ $f_{IF} = 950\text{ kHz}/989\text{ kHz}/1\text{ MHz}$ $f_{IF} -150\text{ kHz}$ to $+150\text{ kHz}$ $f_{IF} -200\text{ kHz}$ to $+200\text{ kHz}$ $f_{IF} -260\text{ kHz}$ to $+260\text{ kHz}$ $P_{FSK} = P_{Ref_FSK} + \Delta P_{Ref}$	ΔP_{Ref}	+6 +8 +11		-2 -2 -2	dB dB dB
S/N ratio to suppress inband noise signals. Noise signals may have any modulation scheme	ASK mode	SNR_{ASK}		10	12	dB
	FSK mode	SNR_{FSK}		2	3	dB
Dynamic range RSSI amplifier		ΔR_{RSSI}		60		dB

18. Electrical Characteristics (continued)

All parameters refer to GND, $T_{amb} = -40^{\circ}\text{C}$ to $+105^{\circ}\text{C}$, $V_S = 4.5\text{V}$ to 5.5V , $f_0 = 868.3\text{ MHz}$ and $f_0 = 915\text{ MHz}$, unless otherwise specified. (For typical values: $V_S = 5\text{V}$, $T_{amb} = 25^{\circ}\text{C}$)

Parameters	Test Conditions	Symbol	Min.	Typ.	Max.	Unit
Lower cut-off frequency of the data filter	$f_{cu_DF} = \frac{1}{2 \times \pi \times 30\text{ k}\Omega \times \text{CDEM}}$ CDEM = 33 nF	fcu_DF	0.11	0.16	0.20	kHz
Recommended CDEM for best performance	BR_Range0 (default) BR_Range1 BR_Range2 BR_Range3	CDEM		39 22 12 8.2		nF nF nF nF
Edge-to-edge time period of the input data signal for full sensitivity	BR_Range0 (default) BR_Range1 BR_Range2 BR_Range3	t_{ee_sig}	270 156 89 50		1000 560 320 180	μs μs μs μs
Upper cut-off frequency data filter	Upper cut-off frequency programmable in 4 ranges via a serial mode word BR_Range0 (default) BR_Range1 BR_Range2 BR_Range3	fu	2.8 4.8 8.0 15.0	3.4 6.0 10.0 19.0	4.0 7.2 12.0 23.0	kHz kHz kHz kHz
Reduced sensitivity	300 kHz IF-filter R_{Sense} connected from pin Sens to V_S , input matched according to Figure 14-1 on page 30 , $f_{in} = 868.3\text{ MHz}/915\text{ MHz}$, $V_S = 5\text{V}$, $T_{amb} = +25^{\circ}\text{C}$					dBm (peak level)
	$R_{Sense} = 56\text{ k}\Omega$	P_{Ref_Red}	-67	-72	-77	dBm
	$R_{Sense} = 100\text{ k}\Omega$	P_{Ref_Red}	-76	-81	-86	dBm
	600 kHz IF-filter R_{Sense} connected from pin Sens to V_S , input matched according to Figure 14-1 on page 30 , $f_{in} = 868.3\text{ MHz}/915\text{ MHz}$, $V_S = 5\text{V}$, $T_{amb} = +25^{\circ}\text{C}$					dBm (peak level)
	$R_{Sense} = 56\text{ k}\Omega$	P_{Ref_Red}	-63	-68	-73	dBm
Reduced sensitivity variation over full operating range	$R_{Sense} = 56\text{ k}\Omega$ $R_{Sense} = 100\text{ k}\Omega$ $P_{Red} = P_{Ref_Red} + \Delta P_{Red}$	ΔP_{Red}	5 5	0 0	0 0	dB dB
	Values relative to $R_{Sense} = 56\text{ k}\Omega$ $R_{Sense} = 56\text{ k}\Omega$ $R_{Sense} = 68\text{ k}\Omega$ $R_{Sense} = 82\text{ k}\Omega$ $R_{Sense} = 100\text{ k}\Omega$ $R_{Sense} = 120\text{ k}\Omega$ $R_{Sense} = 150\text{ k}\Omega$ $P_{Red} = P_{Ref_Red} + \Delta P_{Red}$	ΔP_{Red}		0 -3.5 -6.0 -9.0 -11.0 -13.5		dB dB dB dB dB
Threshold voltage for reset		$V_{ThRESET}$	1.95	2.8	3.75	V



18. Electrical Characteristics (continued)

All parameters refer to GND, $T_{amb} = -40^{\circ}\text{C}$ to $+105^{\circ}\text{C}$, $V_S = 4.5\text{V}$ to 5.5V , $f_0 = 868.3\text{ MHz}$ and $f_0 = 915\text{ MHz}$, unless otherwise specified.
(For typical values: $V_S = 5\text{V}$, $T_{amb} = 25^{\circ}\text{C}$)

Parameters	Test Conditions	Symbol	Min.	Typ.	Max.	Unit
Digital Ports						
Data output						
- Saturation voltage Low	$I_{ol} \leq 12\text{ mA}$	V_{ol}		0.35	0.8	V
	$I_{ol} = 2\text{ mA}$	V_{ol}		0.08	0.3	V
- max voltage at pin DATA		V_{oh}			20	V
- quiescent current	$V_{oh} = 20\text{V}$	I_{qu}			20	μA
- short-circuit current	$V_{ol} = 0.8\text{V}$ to 20V	I_{ol_lim}	13	30	45	mA
- ambient temp. in case of permanent short-circuit	$V_{oh} = 0\text{V}$ to 20V	t_{amb_sc}			85	$^{\circ}\text{C}$
Data input						
- Input voltage Low		V_{ll}			$0.35 \times V_S$	V
- Input voltage High		V_{ich}	$0.65 \times V_S$			V
DATA_CLK output						
- Saturation voltage Low	IDATA_CLK = 1mA	V_{ol}		0.1	0.4	V
- Saturation voltage High	IDATA_CLK = -1mA	V_{oh}	$V_S - 0.4\text{V}$	$V_S - 0.15\text{V}$		V
IIC_ACTIVE output						
- Saturation voltage Low	IIC_ACTIVE = 1 mA	V_{ol}		0.1	0.4	V
- Saturation voltage High	IIC_ACTIVE = -1 mA	V_{oh}	$V_S - 0.4\text{ V}$	$V_S - 0.15\text{ V}$		V
POLLING/_ON input						
- Low level input voltage	Receiving mode	V_{ll}			$0.2 \times V_S$	V
- High level input voltage	Polling mode	V_{lh}	$0.8 \times V_S$			V
TEST 4 pin						
- High level input voltage	Test input must always be set to High	V_{lh}	$0.8 \times V_S$			V
TEST 1 pin						
- Low level input voltage	Test input must always be set to Low	V_{ll}			$0.2 \times V_S$	V

19. Ordering Information

Extended Type Number	Package	Remarks
ATA5760N-TGSY	SO20	Tube, for 868 MHz ISM band, Pb-free, $B_{IF} = 600$ kHz
ATA5760N-TGQY	SO20	Taped and reeled, for 868 MHz ISM band, Pb-free, $B_{IF} = 600$ kHz
ATA5761N-TGSY	SO20	Tube, for 915 MHz ISM band, Pb-free, $B_{IF} = 600$ kHz
ATA5761N-TGQY	SO20	Taped and reeled, for 915 MHz ISM band, Pb-free, $B_{IF} = 600$ kHz
ATA5760N3-TGQY	SO20	Taped and reeled, for 868 MHz ISM band, Pb-free, $B_{IF} = 300$ kHz

20. Package Information

Package SO20

Dimensions in mm

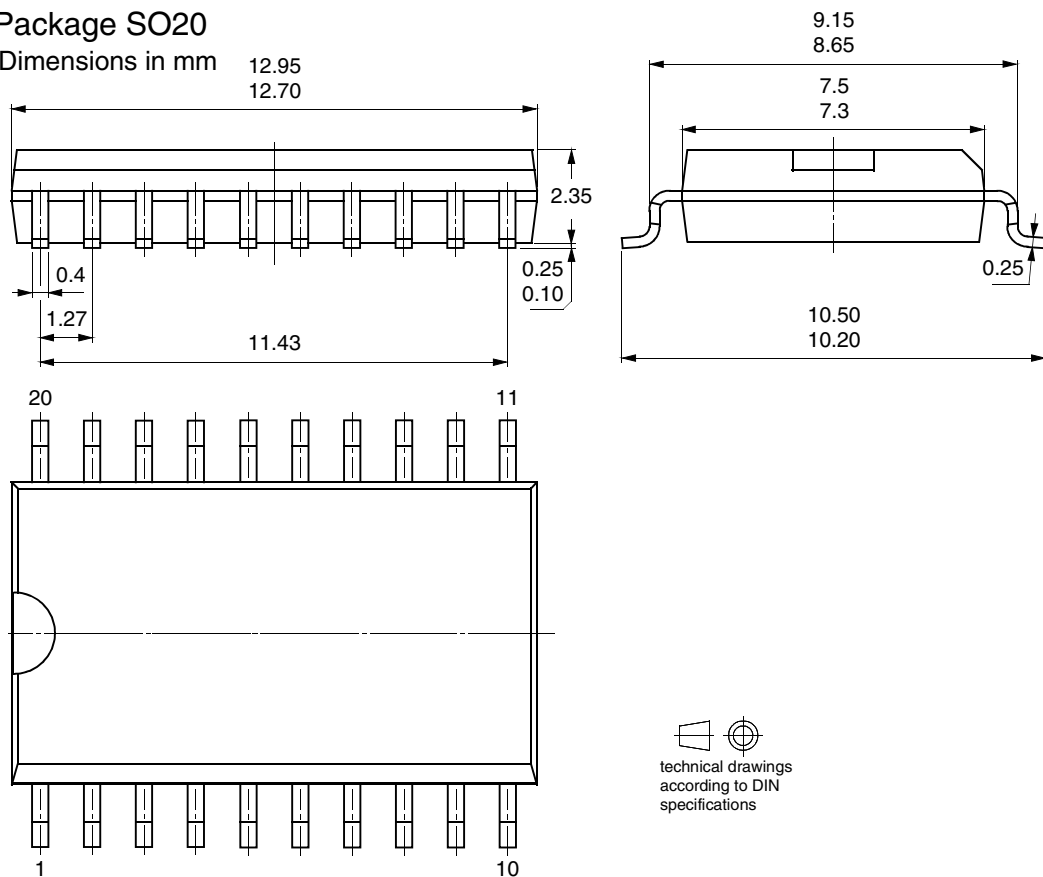

 technical drawings according to DIN specifications



21. Revision History

Please note that the following page numbers referred to in this section refer to the specific revision mentioned, not to this document.

Revision No.	History
4896D-RKE-08/08	<ul style="list-style-type: none">• Put datasheet in the newest template• Page 37: Section 18 "Electrical Characteristics" changed
4896C-RKE-04/06	<ul style="list-style-type: none">• Page 4: first paragraph changed• Page 5: text changed• Page 4.1 IF Filter: text changed• Page 10: text changed• Page 30: figures 14-1 and 14-2 changed• Page 31: El.Char. Table: heading row changed• Page 35-36: Test condition values changed
4896B-RKE-02/06	<ul style="list-style-type: none">• Page 1: PB-free logo deleted• Page 1: Features changed• Page 4: RF Front End - text changed• Page 5: IF Filter - text changed• Page 7: Receiving Characteristics - text changed• Page 7: Fig.5-1 - Title text changed• Page 8: Fig.5-2 - Title text changed• Pages 33 to 37: some lines changed• Page 38: Ordering Information table changed



Headquarters

Atmel Corporation
2325 Orchard Parkway
San Jose, CA 95131
USA
Tel: 1(408) 441-0311
Fax: 1(408) 487-2600

International

Atmel Asia
Room 1219
Chinachem Golden Plaza
77 Mody Road Tsimshatsui
East Kowloon
Hong Kong
Tel: (852) 2721-9778
Fax: (852) 2722-1369

Atmel Europe
Le Krebs
8, Rue Jean-Pierre Timbaud
BP 309
78054
Saint-Quentin-en-Yvelines Cedex
France
Tel: (33) 1-30-60-70-00
Fax: (33) 1-30-60-71-11

Atmel Japan
9F, Tonetsu Shinkawa Bldg.
1-24-8 Shinkawa
Chuo-ku, Tokyo 104-0033
Japan
Tel: (81) 3-3523-3551
Fax: (81) 3-3523-7581

Product Contact

Web Site
www.atmel.com

Technical Support
auto_control@atmel.com

Sales Contact
www.atmel.com/contacts

Literature Requests
www.atmel.com/literature

Disclaimer: The information in this document is provided in connection with Atmel products. No license, express or implied, by estoppel or otherwise, to any intellectual property right is granted by this document or in connection with the sale of Atmel products. **EXCEPT AS SET FORTH IN ATMEL'S TERMS AND CONDITIONS OF SALE LOCATED ON ATMEL'S WEB SITE, ATMEL ASSUMES NO LIABILITY WHATSOEVER AND DISCLAIMS ANY EXPRESS, IMPLIED OR STATUTORY WARRANTY RELATING TO ITS PRODUCTS INCLUDING, BUT NOT LIMITED TO, THE IMPLIED WARRANTY OF MERCHANTABILITY, FITNESS FOR A PARTICULAR PURPOSE, OR NON-INFRINGEMENT. IN NO EVENT SHALL ATMEL BE LIABLE FOR ANY DIRECT, INDIRECT, CONSEQUENTIAL, PUNITIVE, SPECIAL OR INCIDENTAL DAMAGES (INCLUDING, WITHOUT LIMITATION, DAMAGES FOR LOSS OF PROFITS, BUSINESS INTERRUPTION, OR LOSS OF INFORMATION) ARISING OUT OF THE USE OR INABILITY TO USE THIS DOCUMENT, EVEN IF ATMEL HAS BEEN ADVISED OF THE POSSIBILITY OF SUCH DAMAGES.** Atmel makes no representations or warranties with respect to the accuracy or completeness of the contents of this document and reserves the right to make changes to specifications and product descriptions at any time without notice. Atmel does not make any commitment to update the information contained herein. Unless specifically provided otherwise, Atmel products are not suitable for, and shall not be used in, automotive applications. Atmel's products are not intended, authorized, or warranted for use as components in applications intended to support or sustain life.

© 2008 Atmel Corporation. All rights reserved. Atmel®, logo and combinations thereof, and others are registered trademarks or trademarks of Atmel Corporation or its subsidiaries. Other terms and product names may be trademarks of others.

Looking for pricing, stock, or lifecycle information?

Click below to explore more details on WIN SOURCE:

- ⊖ [View ATA5760N3-TGQY on WIN SOURCE](#)
- ⊖ [Microchip Technology Information](#)

Optimize Your Supply Chain with WIN SOURCE Solutions

- ✓ Global Sourcing Solution
- ✓ Obsolete Management
- ✓ Cost Control Management
- ✓ Shortage Management
- ✓ Alternative Solution
- ✓ Excess Inventory Management