



**THE DATASHEET OF  
AT91M40400-25AC**



---

## Features

- Incorporates the ARM7TDMI™ ARM Thumb Processor
  - High-performance 32-bit RISC Architecture
  - High-density 16-bit Instruction Set
  - Leader in MIPS/Watt
  - Embedded ICE In Circuit Emulation
- 4K Bytes Internal RAM
- Fully Programmable External Bus Interface (EBI)
  - Maximum External Address Space of 64M Bytes
  - Up to Eight Chip Selects
  - Software Programmable 8/16-bit External Databus
- Eight-level Priority, Individually Maskable, Vectored Interrupt Controller
  - Four External Interrupts, Including a High-priority Low-latency Interrupt Request
- 32 Programmable I/O Lines
- Three-channel 16-bit Timer/Counter
  - Three External Clock Inputs
  - Two Multi-purpose I/O Pins per Channel
- Two USARTs
  - Two Dedicated Peripheral Data Controller (PDC) Channels per USART
- Programmable Watchdog Timer
- Low-power Idle and Power-down Modes
- Fully Static Operation: 0 Hz to 33 MHz
- 2.7V to 3.6V Operating Range
- Available in a 100-lead TQFP Package

## Description

The AT91M40400 is a member of the Atmel AT91 16/32-bit Microcontroller family which is based on the ARM7TDMI embedded processor. This processor has a high-performance 32-bit RISC architecture with a high-density 16-bit instruction set and very low power consumption. In addition, a large number of internally-banked registers result in very fast exception handling, making the device ideal for real-time control applications. The AT91 ARM-based MCU family also features Atmel's high-density, nonvolatile memory technology. The on-chip Flash program memory is in-system programmable.

The AT91M40400 has a direct connection to off-chip memory, including Flash, through the External Bus Interface (EBI).

The device is manufactured using Atmel's high-density CMOS technology. By combining the ARM7TDMI microcontroller core with an on-chip RAM and a wide range of peripheral functions on a monolithic chip, the Atmel AT91M40400 is a powerful microcontroller that provides a flexible, cost-effective solution to many compute-intensive embedded control applications.



---

## 16/32-Bit Microcontroller

---

## AT91M40400 Electrical and Mechanical Characteristics



# Pin Configuration

Figure 1. AT91M40400 Pinout (Top View)

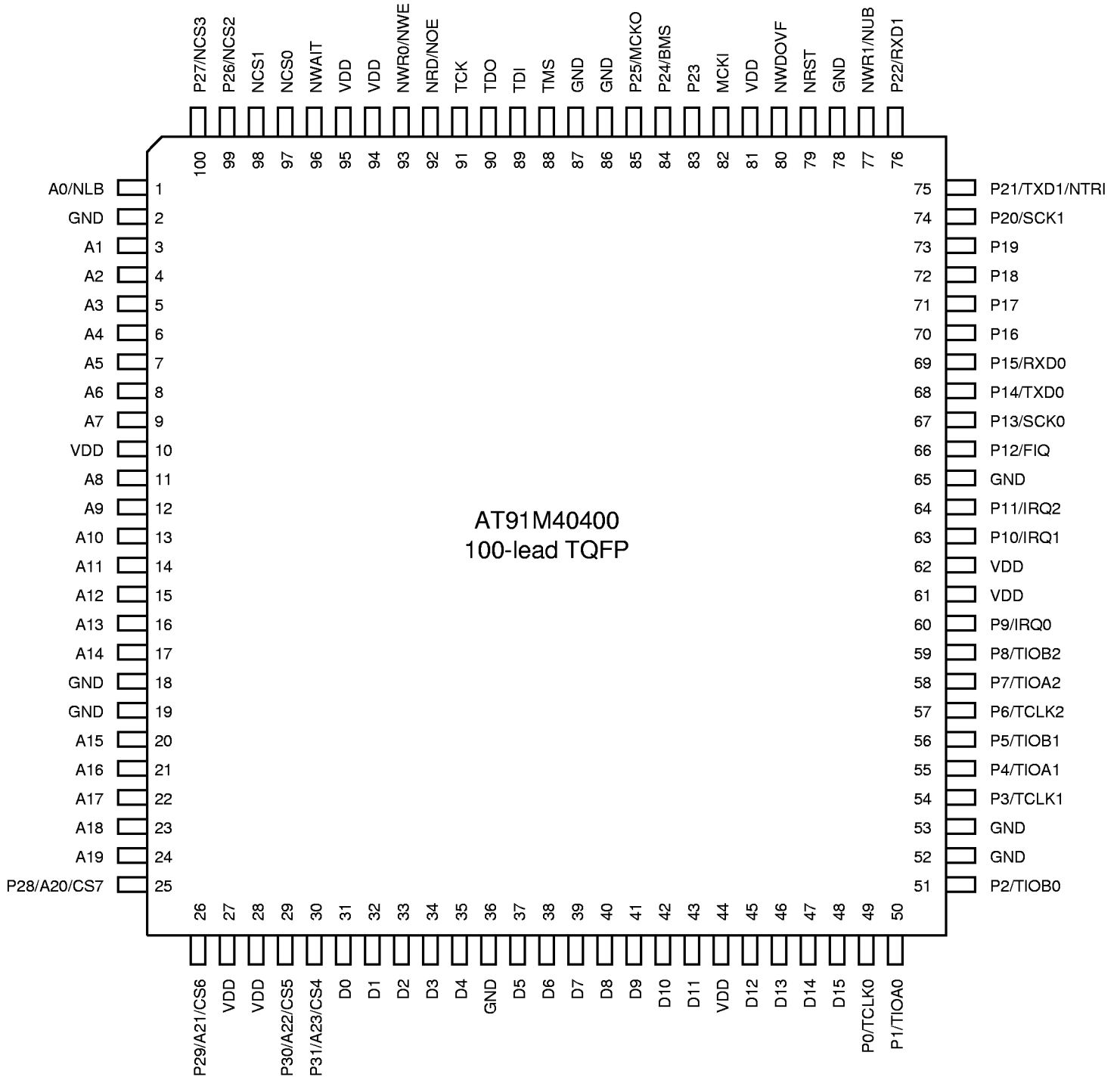

**Table 1.** AT91M40400 Pin Description

Module	Name	Function	Type	Active Level	Comments
EBI	A0-A23	Address Bus	Output	--	All valid after reset
	D0-D15	Data Bus	I/O	--	
	NCS0-NCS3	Chip Select	Output	low	
	CS4-CS7	Chip Select	Output	high	A23-A20 after reset
	NWR0	Lower Byte 0 Write Signal	Output	low	Used in Byte Write Option
	NWR1	Upper Byte 1 Write Signal	Output	low	Used in Byte Write Option
	NRD	Read Signal	Output	low	Used in Byte Write Option
	NWE	Write Enable	Output	low	Used in Byte Select Option
	NOE	Output Enable	Output	low	Used in Byte Select Option
	NUB	Upper Byte Select	Output	low	Used in Byte Select Option
	NLB	Lower Byte Select	Output	low	Used in Byte Select Option
	NWAIT	Wait Input	Input	low	
BMS	Boot Mode Select	Input	--	Sampled during reset	
AIC	FIQ	Fast Interrupt Request	Input	--	PIO controlled after reset
	IRQ0-IRQ2	External Interrupt Request	Input	--	PIO controlled after reset
Timer	TCLK0-TCLK2	Timer External Clock	Input	--	PIO controlled after reset
	TIOA0-TIOA2	Multipurpose Timer I/O pin A	I/O	--	PIO controlled after reset
	TIOB0-TIOB2	Multipurpose Timer I/O pin B	I/O	--	PIO controlled after reset
USART	SCK0-SCK1	External Serial Clock	I/O	--	PIO controlled after reset
	TXD0-TXD1	Transmit Data Output	Output	--	PIO controlled after reset
	RXD0-RXD1	Receive Data Input	Input	--	PIO controlled after reset
PIO	P0-P31	Parallel IO line	I/O	--	
WD	NWDOVF	Watchdog overflow	Output	low	Open drain
Clock	MCKI	Master Clock Input	Input	--	Schmidt trigger
	MCKO	Master Clock Output	Output	--	
Reset	NRST	Hardware Reset Input	Input	low	Schmidt trigger, internal pull-up
	NTRI	Tristate Mode Select	Input	low	Sampled during reset
ICE	TMS	Test Mode Select	Input	--	Schmidt trigger, internal pull-up
	TDI	Test Data Input	Input	--	Schmidt trigger, internal pull-up
	TDO	Test Data Output	Output	--	
	TCK	Test Clock	Input	--	Schmidt trigger, internal pull-up
Power	VDD	Power			
	GND	Ground			



## Absolute Maximum Ratings\*

Operating Temperature (Commercial) .....	0 to +70°C
Operating Temperature (Industrial).....	-40°C to +85°C
Voltage on any input Pin with respect to Ground .....	-0.5V to +5.5V
Maximum Operating Voltage .....	4.6V
DC Output Current .....	2 mA

\*NOTICE: Stresses beyond those listed under “Absolute Maximum Ratings” may cause permanent damage to the device. This is a stress rating only and functional operation of the device at these or other conditions beyond those indicated in the operational sections of this specification is not implied. Exposure to absolute maximum rating conditions for extended periods may affect device reliability.

## DC Characteristics

$T_A = -40^{\circ}\text{C}$  to  $85^{\circ}\text{C}$ ,  $V_{CC} = 2.7\text{V}$  to  $3.6\text{V}$  unless otherwise specified. All pads are 5V tolerant.

**Table 2.** DC Characteristics

Symbol	Parameter	Condition	Min	Typ	Max	Units
$V_{IL}$	Input Low Voltage	$V_{CC} = 2.7\text{V}$ to $3.6\text{V}$	-0.5		$0.3 \times V_{CC}$	V
$V_{IH}$	Input High Voltage	$V_{CC} = 2.7\text{V}$ to $3.6\text{V}$	$0.7 \times V_{CC}$		$V_{CC} + 0.5$	V
$V_{IH}$	Input High Voltage	$V_{CC} = 2.7\text{V}$ to $3.6\text{V}$	$0.7 \times V_{CC}$		5.5	V
$V_{OL}$	Output Low Voltage	$I_{OL} = 0.8\text{ mA}$ , $V_{CC} = 3.0\text{V}$			$V_{SS} + 0.1$	V
$V_{OH}$	Output High Voltage	$I_{OH} = 0.8\text{ mA}$ , $V_{CC} = 3.0\text{V}$	$V_{CC} - 0.1$			V
$I_{CC}$	Power Supply Current	Active Mode, 33 MHz		41	77	mA
		Active Mode, 25 MHz		32	60	mA
		Active Mode, 16 MHz		21	40	mA
		Active Mode, 8 MHz		11	22	mA
		Active Mode, 4 MHz		6	12	mA
		Idle Mode after reset, 3.6V		30		$\mu\text{A}$
$I_{OH}$	Output Source Current	$V_{CC} = 3.0\text{V}$ , $V_{OH} = 2.4\text{V}$			2	mA
$I_{OL}$	Output Sink Current	$V_{CC} = 3.0\text{V}$ , $V_{OL} = 0.4$			2	mA
$I_{LEAK}$	Input Leakage Current				100	nA
$I_{PULL}$	Input Pull-up Current	$V_{CC} = 3.3\text{V}$ , $V_{IN} = 0$	-400		-80	$\mu\text{A}$
$I_{CAP}$	Input Capacitance for all Pins				12	pF

## Conditions

### Environment Constraints

The output delays are valid for a capacitive load of 50pF as shown in the diagram below.

**Figure 2.** Output/Bidir Pad Capacitive Load

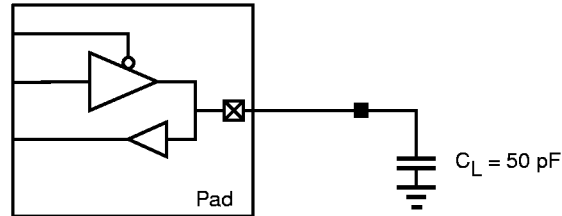

**Table 3.** Environment Constraints

Parameter	Best Case	Nominal Case	Worst Case	
			Commercial	Industrial
Ambient Temperature	-40°C	25°C	70°C	85°C
Supply Voltage, Vdd	3.6V	3.3V	2.7V	2.7V

### Timing Results

The output delays are for a capacitive load of 50pF as shown in Figure 2 above.

In order to obtain the timing for other capacitance values, the following equation should be used.

$$t = t_{datasheet} + factor \times (C_{load} - 50pF)$$

**Table 4.** Derating Factor Due to Capacitive Load Variation

Parameter	Best Case	Nominal Case	Worst Case		Units
			Commercial	Industrial	
Factor	0.0019	0.034	0.052	0.058	ns/pF

## AC Characteristics

The following table shows the Minimum and Maximum timings for external memory read/write (valid for all conditions of operation). See Figures 3 and 4.

**Table 5.** External Memory Read/Write Timings

Symbol	Parameter	Minimum	Maximum			Units
			AT91M40400 -25AC	AT91M40400 -25AI	AT91M40400 -33AC	
$t_{AHRH}$	Address Hold After NRD High	0				ns
$t_{AHHW}$	Address Hold After NWR High	2				ns
$t_{AVRL}$	Address Valid to NRD Low	0				ns
$t_{AVWL}$	Address Valid to NWR Low	$t_{CL} - 6$				ns
$t_{CA}$	Chip Select Active Pulse Width	$t_{CP} - 2$				ns
$t_{CARL}$	Chip Select Active to NRD Low	0				ns
$t_{CAUBL}$	Chip Select Active to NUB Low	0				ns
$t_{DF}$	Data Float After NRD High		$7(t_{CP})$			ns
$t_{DVWH}$	Data Out Valid Before NWR High	$t_{CH} - 5$				ns
$t_{RHCD}$	NRD High to Chip Select Disabled	0				ns
$t_{RHDX}$	Data Hold After NRD High	0.6				ns
$t_{RLDV}$	NRD Low to Valid Data (0 Wait States)		$t_{CP} - 21$ <sup>(1)</sup>	$t_{CP} - 21$ <sup>(1)</sup>	$t_{CP} - 14.7$ <sup>(1)</sup>	ns
			$t_{CH} - 13$ <sup>(2)</sup>	$t_{CH} - 13$ <sup>(2)</sup>	$t_{CH} - 9.1$ <sup>(2)</sup>	ns
$t_{RLRH}$	NRD Pulse Width	$t_{CP} - 2$ <sup>(1)</sup>				ns
		$t_{CP}/2 - 2$ <sup>(2)</sup>				ns
$t_{UBHCD}$	NUB High to Chip Select Disabled	0				ns
$t_{WACK}$	NWAIT Setup Before MCKI High	8				ns
$t_{WAHCK}$	NWAIT Hold After MCKI High	4				ns
$t_{WHCD}$	NWR High to Chip Select Disabled	2				ns
$t_{WHDX}$	Data Out Hold After NWR High	2				ns
$t_{WHRL}$	NWR High to NRD Low	$t_{CL}$				ns
$t_{WHUBH}$	NWR High to NUB High	2				ns
$t_{WLWH}$	NWR Pulse Width	$t_{CP}/2 - 2$				ns

- Notes: 1. Early Read Protocol  
2. Standard Read Protocol

Figure 3. External Data Memory Read Cycle

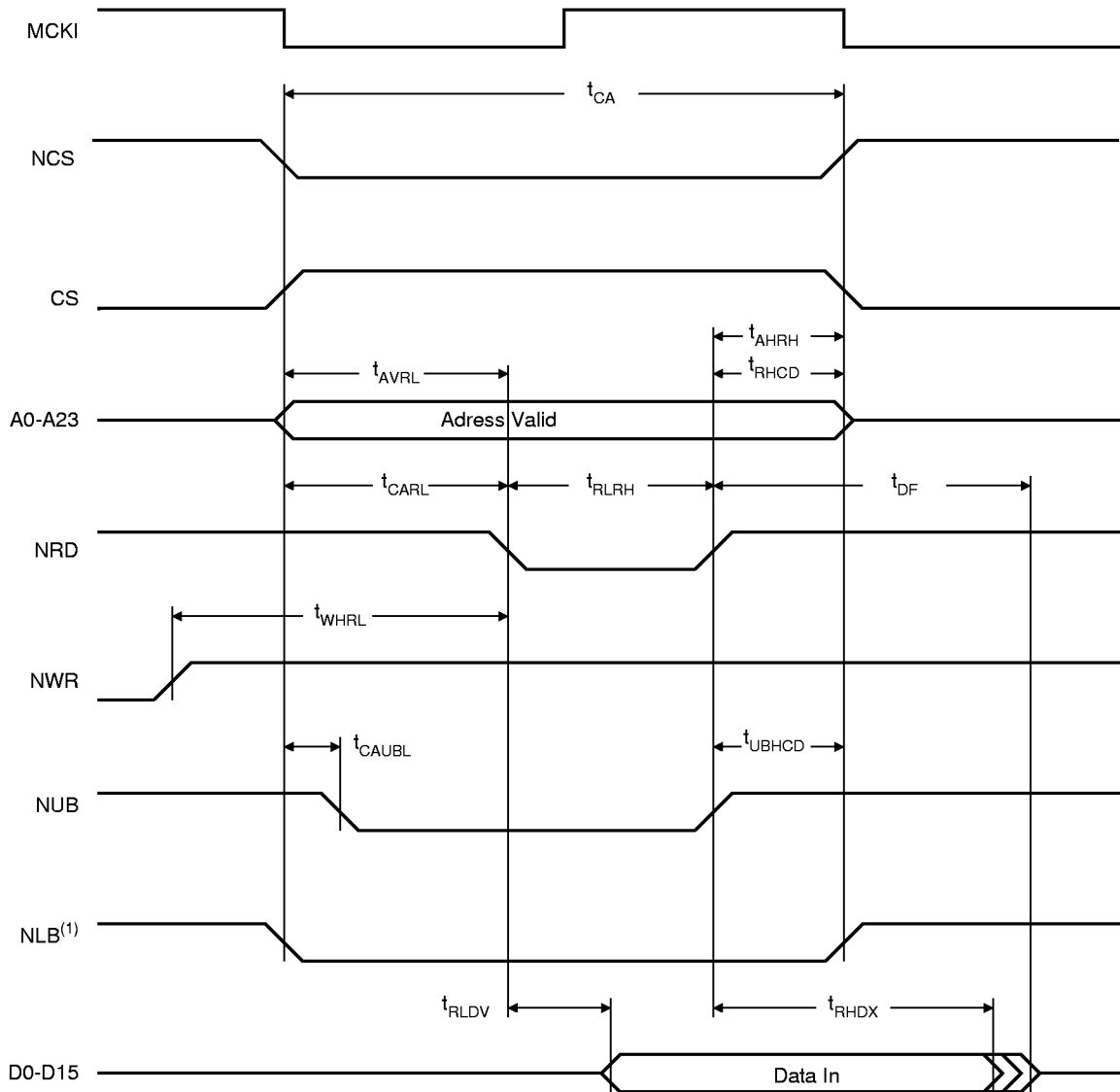

Note: 1. Timing of NLB is equal to timing of A0-A23.

**Figure 4.** External Data Memory Write Cycle

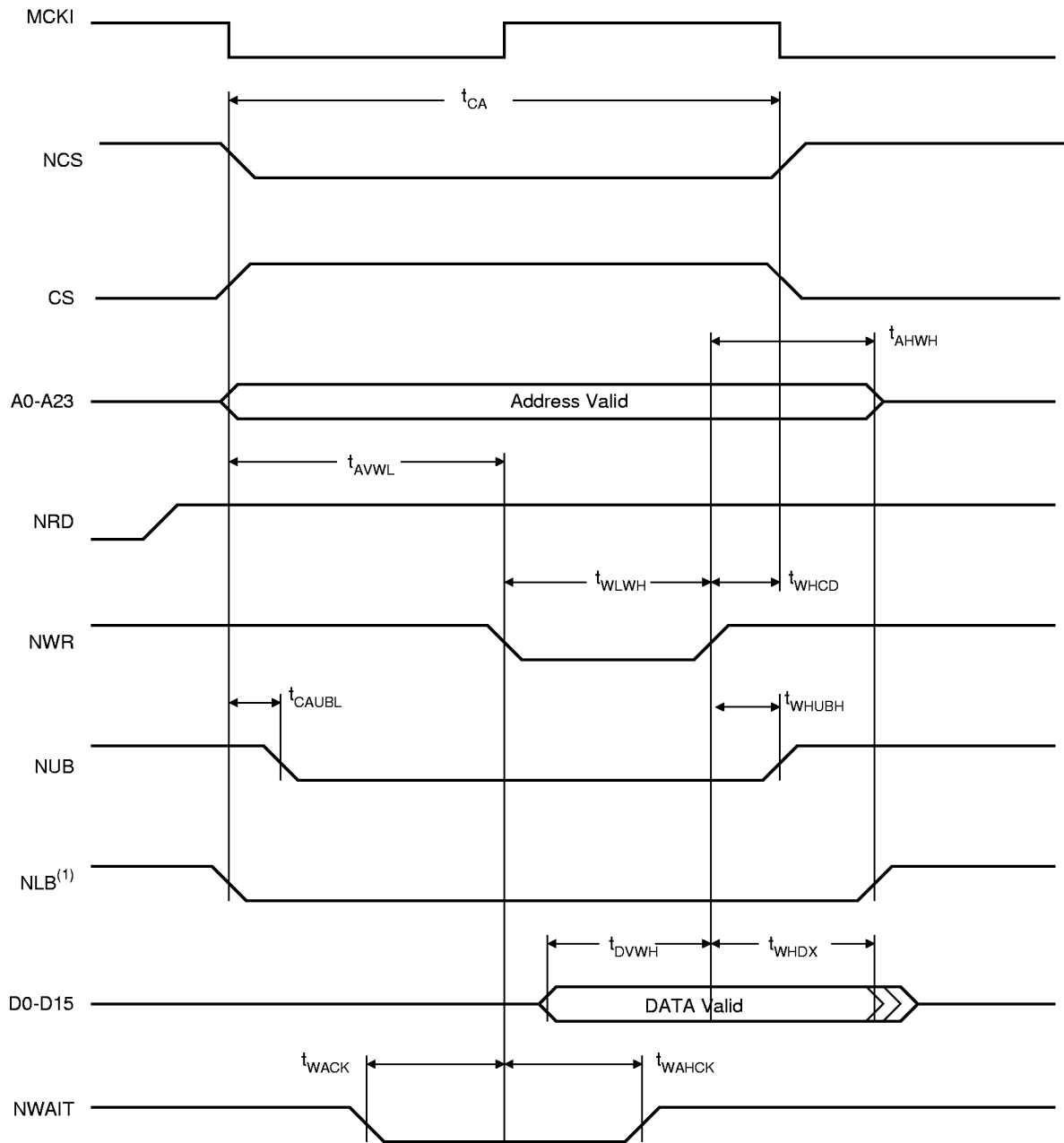

Note: 1. Timing of NLB is equal to timing of A0-A23.

## EBI Signals Relative to MCKI

The following tables show timings relative to operating condition limits (best case and worst case). See Figure 5.

**Table 6.** General Purpose EBI Signals

Symbol	Parameter	Best Case	Worst Case			Units
			-25AC	-25AI	-33AC	
EBI <sub>1</sub>	MCKI Falling to NUB Valid	6	21	22	15	ns
EBI <sub>2</sub>	MCKI Falling to NLB/A0 Valid	6	21	23	15	ns
EBI <sub>3</sub>	MCKI Falling to A7-A1 Valid	6	21	22	15	ns
EBI <sub>4</sub>	MCKI Falling to A23-A8 Valid	6	20	21	14	ns
EBI <sub>5</sub>	MCKI Falling to Chip Select	5	20	21	14	ns
EBI <sub>6</sub>	NWAIT Setup Before MCKI Rising	4	8	8	6	ns
EBI <sub>7</sub>	NWAIT Hold After MCKI Rising	1	5	5	4	ns

**Table 7.** EBI Write Signals

Symbol	Parameter	Best Case	Worst Case			Units
			-25AC	-25AI	-33AC	
EBI <sub>8</sub>	MCKI Rising to NWR Active (No Wait)	4	16	17	12	ns
EBI <sub>9</sub>	MCKI Rising to NWR Active (Wait)	4	17	18	12	ns
EBI <sub>10</sub>	MCKI Falling to NWR Inactive (No Wait)	5	19	20	14	ns
EBI <sub>11</sub>	MCKI Rising to NWR Inactive (Wait)	4	18	19	13	ns
EBI <sub>12</sub>	MCKI Rising to D0-D15 Out Valid	5	21	22	15	ns

**Table 8.** EBI Read Signals

Symbol	Parameter	Best Case	Worst Case			Units
			-25AC	-25AI	-33AC	
EBI <sub>13</sub>	MCKI Falling to NRD <sup>(1)</sup> and <sup>(2)</sup>	5	17	18	12	ns
EBI <sub>14</sub>	MCKI Rising to NRD Valid <sup>(2)</sup>	4	16	17	12	ns
EBI <sub>15</sub>	D0-D15 in Setup Before MCKI Falling	2	3	3	3	ns
EBI <sub>16</sub>	D0-D15 in Hold After MCKI Falling	1	2	2	2	ns

- Notes: 1. Early Read Protocol  
2. Standard Read Protocol

**Figure 5. EBI Signals Relative to MCKI**

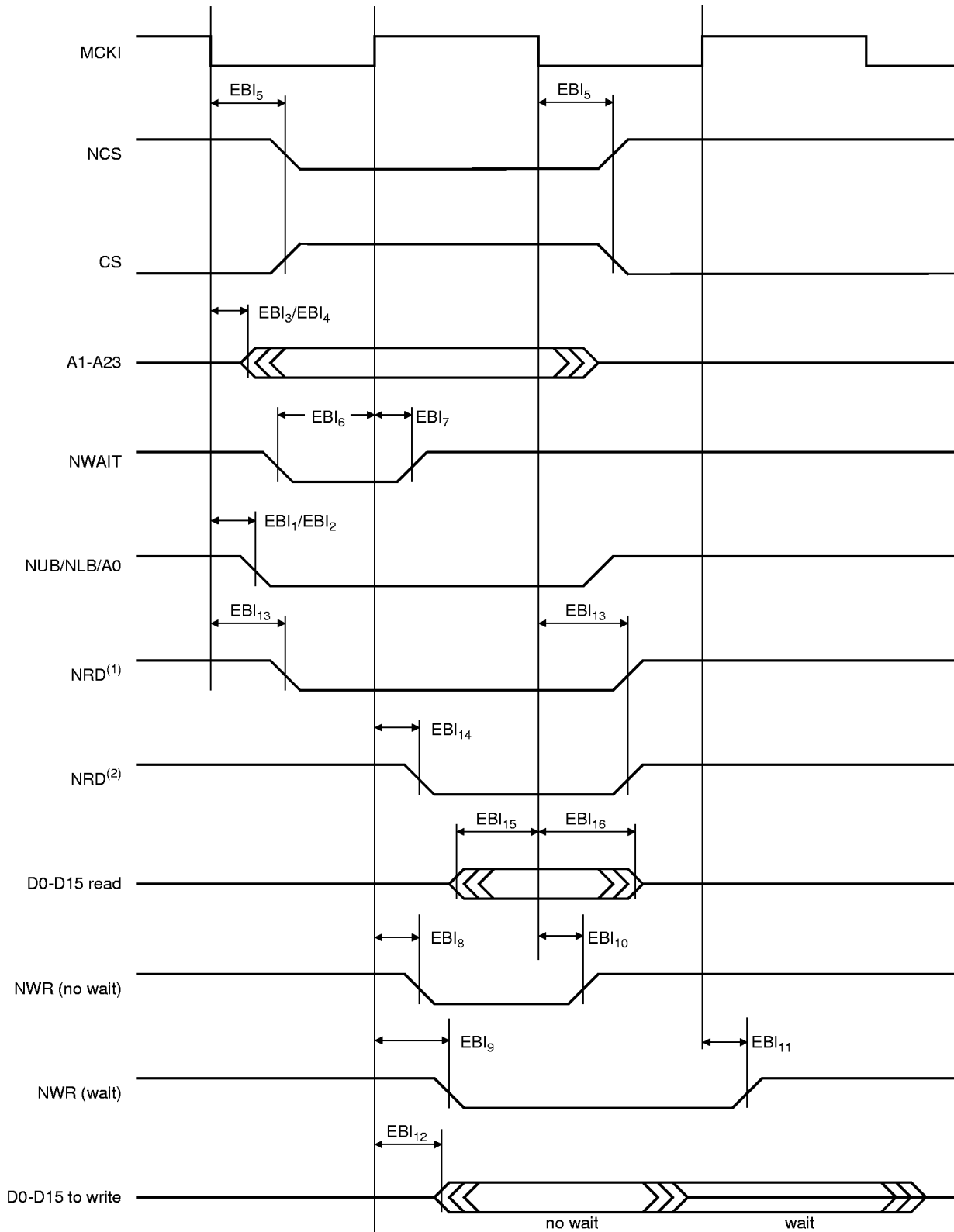

- Notes: 1. Early Read Protocol  
2. Standard Read Protocol

## Peripheral Signals Relative to MCKI

### USART Signals

**Table 9.** USART Outputs

Symbol	Mode	Parameter	Best Case	Worst Case			Units
				-25AC	-25AI	-33AC	
US <sub>1</sub>	Asynchronous	MCKI Rising to SCK Output Rising/Falling	6	23	25	17	ns
US <sub>2</sub>	Asynchronous	MCKI Rising to TXD Toggling	7	25	27	18	ns
US <sub>3</sub>	Synchronous	SCK Output Falling to TXD Toggling	1	4	4	3	ns
US <sub>4</sub>	Synchronous	SCK Input Falling to TXD Toggling	$t_{CP} + 7$	$2(t_{CP}) + 25$	$2(t_{CP}) + 27$	$2(t_{CP}) + 18$	ns

The inputs can be used synchronously or asynchronously (in relation to MCKI).

For synchronous USART inputs, certain setup/hold constraints must be met. These constraints are shown in the Table 10 and are represented in Figure 6.

**Table 10.** USART Setup/Hold Constraints

Symbol	Mode	Parameter	Setup	Hold	Units
US <sub>5</sub>	Asynchronous	RXD Toggling Relative to MCKI Falling	6	2	ns
US <sub>6</sub>	Asynchronous	SCK Input Rising Relative to MCKI Rising	7	1	ns
US <sub>7</sub>	Asynchronous	SCK Input Falling Relative to MCKI Rising	6	1	ns
US <sub>8</sub>	Synchronous	RXD Toggling Relative to SCK Input Rising	$t_{CP} / 2 - 1$	$t_{CP} / 2 + 1$	ns

**Figure 6.** USART Signals Relative to MCKI

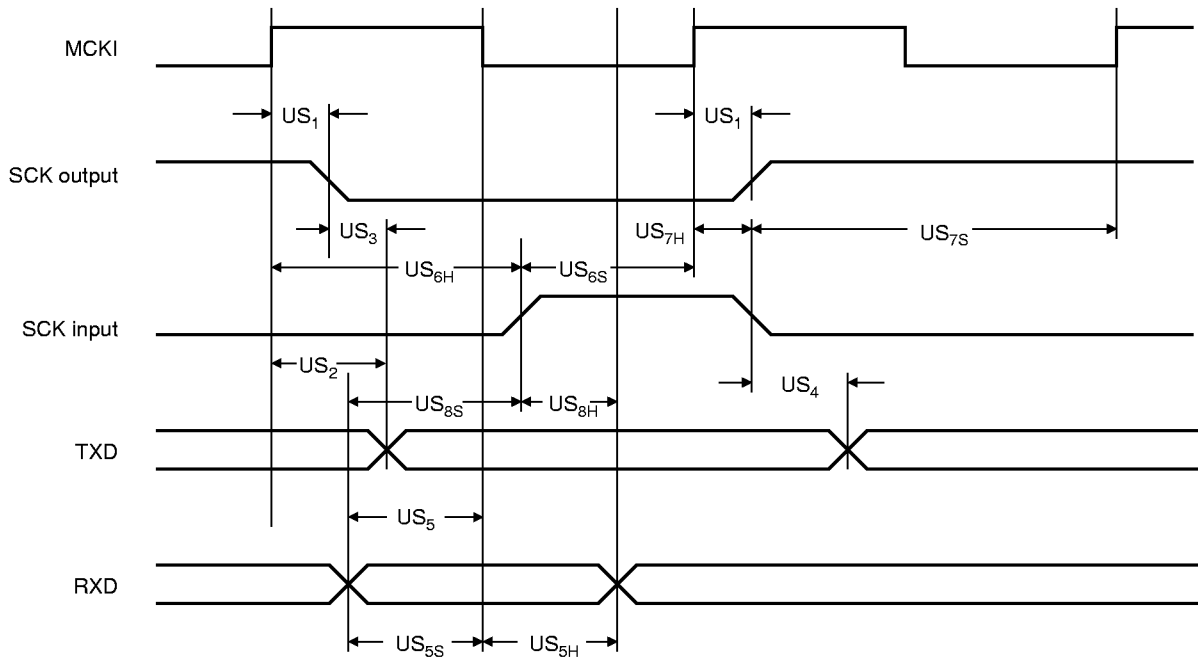

## Timer Counter Signals

Due to internal synchronization of input signals, there is a delay between an input event and a corresponding output event. This delay is  $3(t_{CP})$  in Waveform Event Detection Mode and  $4(t_{CP})$  in Waveform Total-Count Detection Mode.

**Table 11.** Timer Outputs

Symbol	Parameter	Best Case	Worst Case			Units
			-25AC	-25AI	-33AC	
TC <sub>1</sub>	MCKI Rising to TIOA Rising	5	17	18	12	ns
TC <sub>2</sub>	MCKI Rising to TIOA Falling	4	16	17	12	ns
TC <sub>3</sub>	MCKI Rising to TIOB Rising	5	18	19	13	ns
TC <sub>4</sub>	MCKI Rising to TIOB Falling	5	17	18	12	ns

The inputs can be used synchronously or asynchronously (in relation to MCKI).

For synchronous Timer inputs, certain setup/hold constraints must be met. These constraints are shown in the Table 12 and are represented in Figure 7.

For asynchronous inputs, a minimum pulse width and a minimum input period are necessary as shown in Tables 13 and 14 and as represented in Figure 7.

**Table 12.** Timer Synchronous Inputs

Symbol	Type of Input	Parameter	Setup	Hold	Units
TC <sub>5</sub>	Synchronous	TIOA/TIOB Rising Relative to MCKI Rising	5	2	ns
TC <sub>6</sub>	Synchronous	TIOATIOB Falling Relative to MCKI Rising	4	2	ns
TC <sub>7</sub>	Synchronous	TCLK Rising Relative to MCKI Rising	6	1	ns
TC <sub>8</sub>	Synchronous	TCLK Falling Relative to MCKI Rising	5	2	ns

**Table 13.** Timer Asynchronous Input Minimum Pulse Width

Symbol	Type of Inputs	Parameter	Pulse Width	Units
TC <sub>9</sub>	Asynchronous	TCLK/TIOA/TIOB Minimum Pulse Width	$3(t_{CP}/2)$	ns

**Table 14.** Timer Asynchronous Input Minimum Input Period

Symbol	Type of Inputs	Parameter	Input Period	Units
TC <sub>10</sub>	Asynchronous	TCLK/TIOA/TIOB Minimum Input Period	$5(t_{CP}/2)$	ns

Figure 7. Timer Relative to MCKI

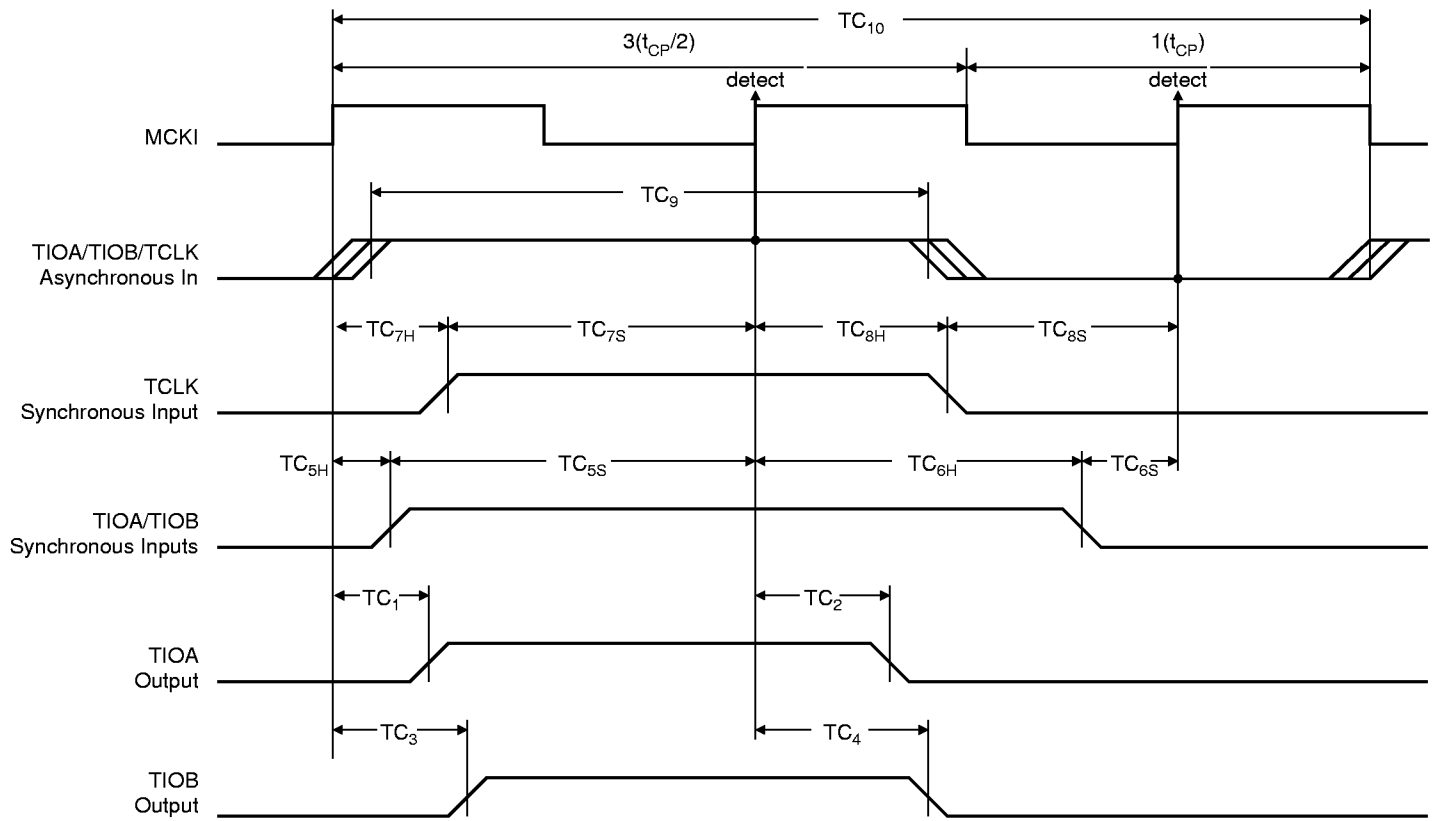

## Watchdog Timer Signals

**Table 15.** Watchdog Timer Outputs

Symbol	Parameter	Best Case	Worst Case			Units
			-25AC	-25AI	-33AC	
WD <sub>1</sub>	MCKI Rising to WDOVF Rising	3	12	13	9	ns
WD <sub>2</sub>	MCKI Rising to WDOVF Falling	4	13	14	10	ns

**Figure 8.** Watchdog Signals Relative to MCKI

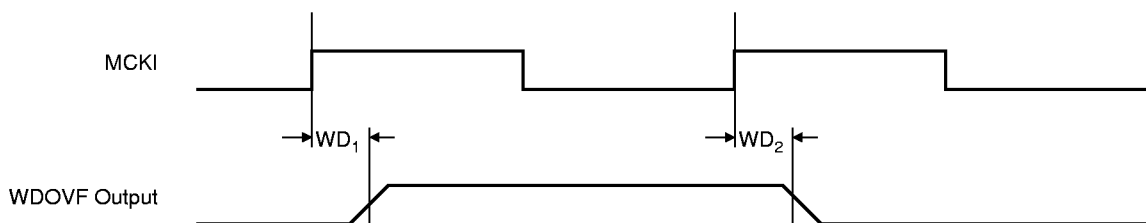

## Reset Signals

Certain setup/hold constraints must be met. These constraints are shown in Table 16 and are represented in Figure 9.

**Table 16.** Reset Setup/Hold Constraints

Symbol	Parameter	Setup	Hold	Units
RST <sub>1</sub>	NRST Rising Related to MCKI Rising	2	2	ns
RST <sub>2</sub>	NRST Falling related to MCKI Rising	2	1	ns

A minimum pulse width is necessary as shown in Table 17 and as represented in Figure 9.

**Table 17.** Reset Minimum Pulse Width

Symbol	Parameter	Pulse Width	Units
RST <sub>3</sub>	NRST Minimum Pulse Width	$10(t_{CP})$	ns

**Figure 9.** Reset Signals Relative to MCKI

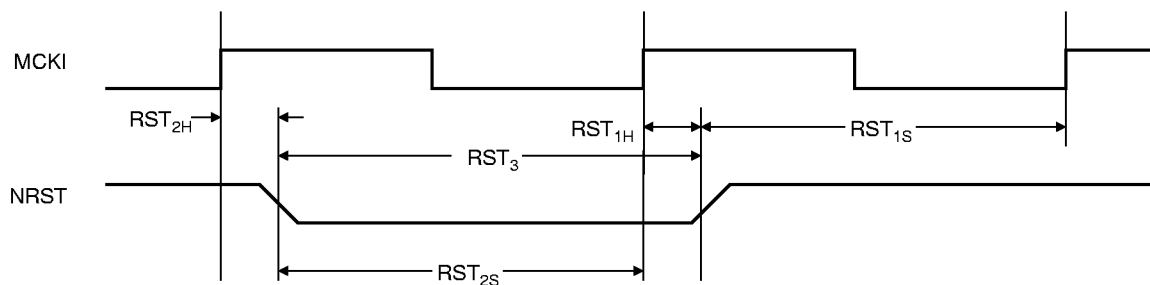

## Advanced Interrupt Controller Signals

The inputs can be used synchronously or asynchronously (in relation to MCKI).

For synchronous AIC inputs, certain setup/hold constraints must be met. These constraints are shown in Table 18 and are represented in Figure 10.

For asynchronous inputs, a minimum pulse width is necessary as shown in Table 19 and as represented in Figure 10.

**Table 18.** AIC Synchronous Input Setup/Hold Constraints

Symbol	Type	Parameter	Setup	Hold	Units
AIC <sub>1</sub>	Synchronous	P24/FIQ/IRQ Rising Relative to MCKI Rising	5	1	ns
AIC <sub>2</sub>	Synchronous	P24/FIQ/IRQ Falling Related to MCKI Rising	5	1	ns
AIC <sub>3</sub>	Synchronous	IRQ Rising Related to MCKI Rising	7	1	ns
AIC <sub>4</sub>	Synchronous	IRQ Falling Related to MCKI Rising	6	1	ns

**Table 19.** AIC Asynchronous Input Minimum Pulse Width

Symbol	Type	Parameter	Pulse Width	Units
AIC <sub>5</sub>	Asynchronous	P24/FIQ/IRQ Minimum Pulse Width	$3(t_{CP}/2)$	ns

**Table 20.** AIC Asynchronous Input Minimum Input Period

Symbol	Type	Parameter	Input Period	Units
AIC <sub>6</sub>	Asynchronous	AIC Minimum Input Period	$5(t_{CP}/2)$	ns

**Figure 10.** AIC Signals Relative to MCKI

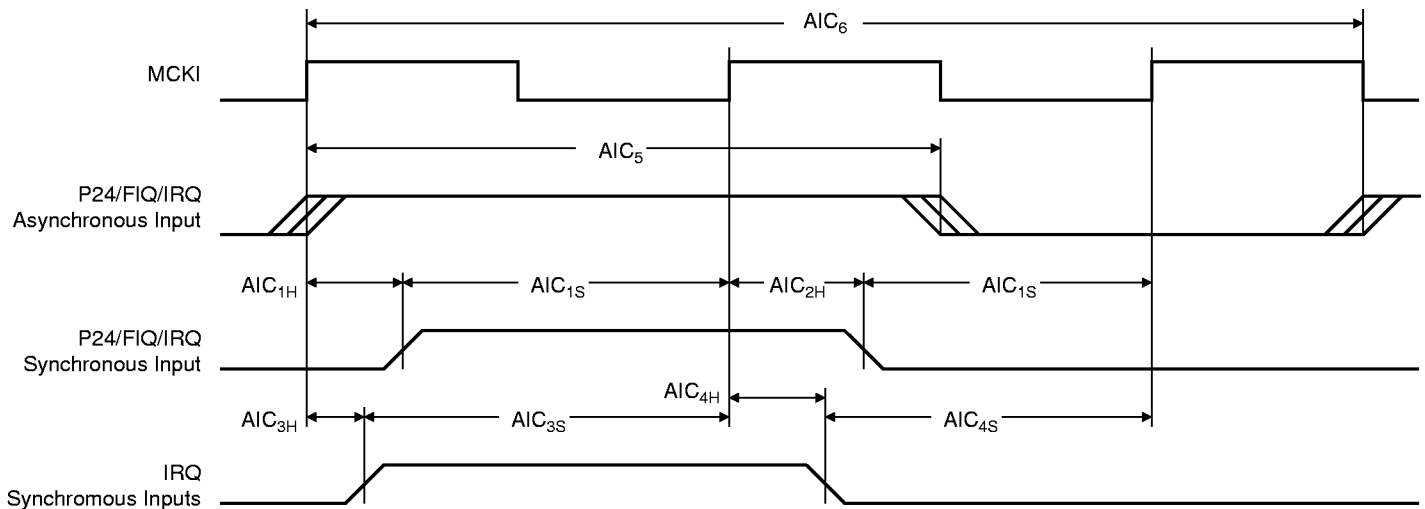

## Parallel I/O Signals

**Table 21.** PIO Outputs

Symbol	Parameter	Best Case	Worst Case			Units
			-25AC	-25AI	-33AC	
PIO <sub>1</sub>	MCKI Falling to PIO Output Rising	4	20	21	15	ns
PIO <sub>2</sub>	MCKI Falling to PIO Output Falling	5	17	18	13	ns

The inputs can be used synchronously or asynchronously (in relation to MCKI).

For synchronous PIO inputs, certain setup/hold constraints must be met. These constraints are shown in the Table 22 and are represented in Figure 11.

For asynchronous inputs, a minimum pulse width is necessary as shown in Table 23 and as represented in Figure 11.

**Table 22.** PIO Synchronous Input Setup/Hold Constraints

Symbol	Type	Parameter	Setup	Hold	Units
PIO <sub>3</sub>	Synchronous	PIO Input Rising Related to MCKI Rising	3	4	ns
PIO <sub>4</sub>	Synchronous	PIO Input Falling Related to MCKI Rising	4	4	ns

**Table 23.** PIO Asynchronous Input Minimum Pulse Width

Symbol	Type	Parameter	Pulse Width	Units
PIO <sub>5</sub>	Asynchronous	PIO Input Minimum Pulse Width	$3(t_{CP}/2)$	ns

**Figure 11.** PIO Signals Relative to MCKI

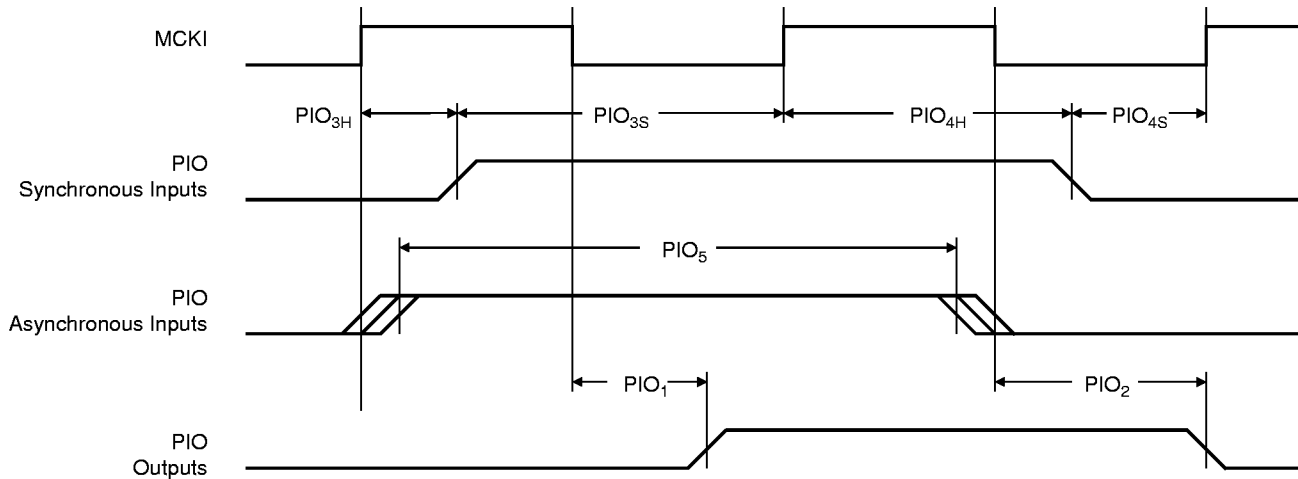

## Clock Waveforms

**Table 24.** Clock Waveform Parameters

Symbol	Parameter	Minimum		Maximum		Units
		-33AC	-25AI	-33AC	-25AI	
$1/t_{CP}$	Oscillator Frequency			33	25	MHz
$t_{CP}$	Main Clock Period	30	40			ns
$t_{CH}$	High Time	12	17			ns
$t_{CL}$	Low Time	12	17			ns

**Table 25.** Clock Propagation Times

Symbol	Parameter	Best Case	Nominal Case	Worst Case			Units
				-25AC	-25AI	-33AC	
$t_{CDLH}$	Rising Edge Propagation Time	3	6	11	12	9	ns
$t_{CDHL}$	Falling Edge Propagation Time	3	6	11	12	9	ns

**Figure 12.** Clock Waveform

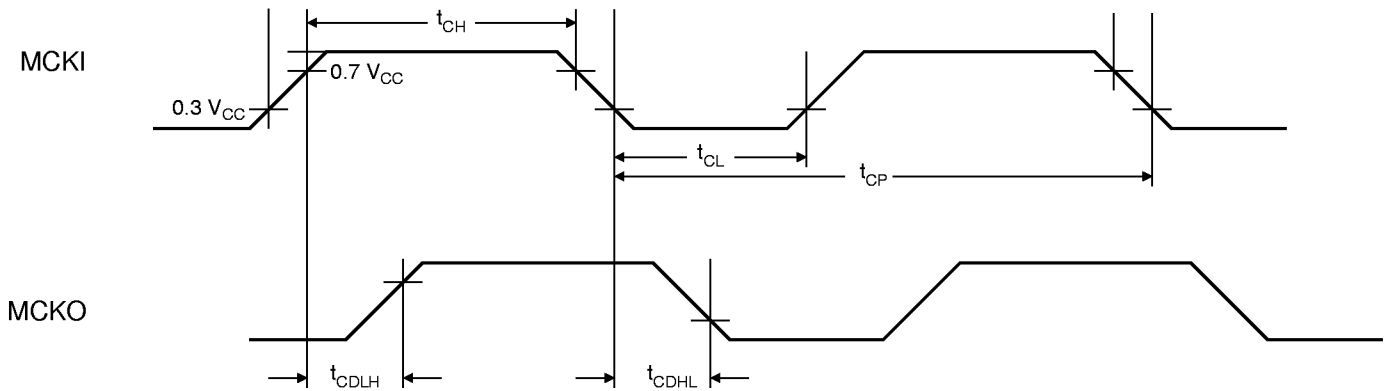

## Package Outline TQPF 100

### 100-Lead, Thin (1.4 mm) Quad Flat Pack

**Table 26.** Common Dimensions (mm)

Symbol	Min	Nom	Max
c	0.09		0.2
c1	0.09		0.16
L	0.45	0.6	0.75
L1	1.00 REF		
R2	0.08		0.2
R1	0.08		
S	0.2		
$\theta$	0°	3.5°	7°
$\theta_1$	0°		
$\theta_2$	11°	12°	13°
$\theta_3$	11°	12°	13°
A			1.6
A1	0.05		0.15
A2	1.35	1.4	1.45
<b>Tolerances of form and position</b>			
aaa		0.2	
bbb		0.2	

**Table 27.** Lead Count Dimensions

Pin Count	D/E BSC	D1/E1 BSC	b			b1			e BSC	ccc	ddd
			Min	Nom	Max	Min	Nom	Max			
100	16.0	14.0	0.17	0.22	0.27	0.17	0.2	0.23	0.50	0.10	0.06

Thermal resistance of package: 40°C/W.

Figure 13. TQFP 100 Package Drawing

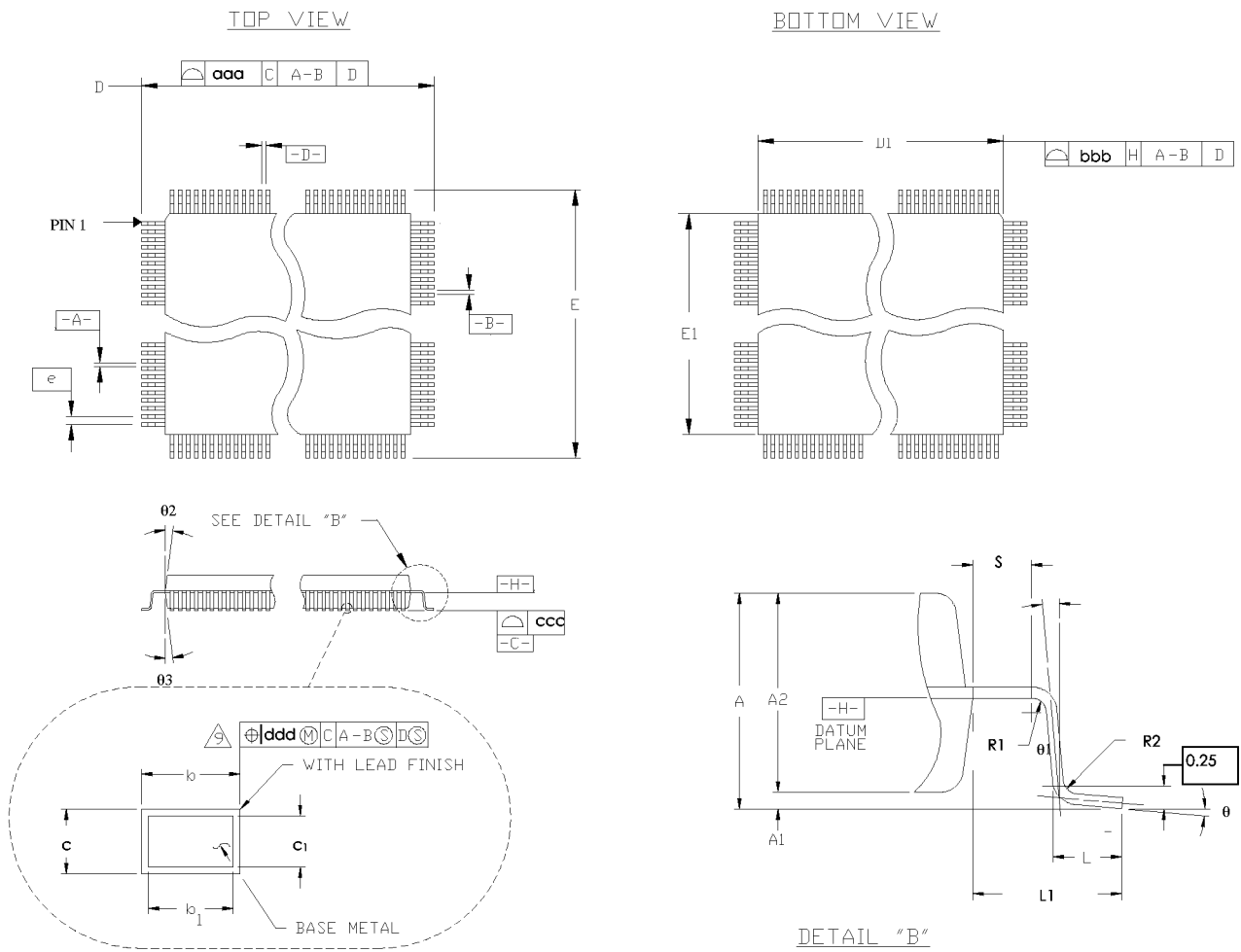





## Ordering Information



Speed (MHz)	Power Supply	Ordering Code	Package	Operation Range
25	2.7V to 3.6V	AT91M40400-25AC	TQFP 100	Commercial (0°C to 70°C)
		AT91M40400-25AI	TQFP 100	Industrial (-40°C to 85°C)
33	2.7V to 3.6V	AT91M40400-33AC	TQFP 100	Commercial (0°C to 70°C)

## Looking for pricing, stock, or lifecycle information?

Click below to explore more details on WIN SOURCE:

-  [View AT91M40400-25AC on WIN SOURCE](#)
-  [Microchip Technology Information](#)

## Optimize Your Supply Chain with WIN SOURCE Solutions

-  Global Sourcing Solution
-  Obsolete Management
-  Cost Control Management
-  Shortage Management
-  Alternative Solution
-  Excess Inventory Management