



**THE DATASHEET OF
AT49BV1614A-90TI**



Features

- Single Voltage Read/Write Operation: 2.65V to 3.3V (BV), 3.0V to 3.6V (LV)
- Access Time – 70 ns
- Sector Erase Architecture
 - Thirty-one 32K Word (64K Bytes) Sectors with Individual Write Lockout
 - Eight 4K Word (8K Bytes) Sectors with Individual Write Lockout
- Fast Word Program Time – 20 μ s
- Fast Sector Erase Time – 300 ms
- Dual-plane Organization, Permitting Concurrent Read while Program/Erase
 - Memory Plane A: Eight 4K Word and Seven 32K Word Sectors
 - Memory Plane B: Twenty-four 32K Word Sectors
- Erase Suspend Capability
 - Supports Reading/Programming Data from Any Sector by Suspending Erase of Any Different Sector
- Low-power Operation
 - 30 mA Active
 - 10 μ A Standby
- Data Polling, Toggle Bit, Ready/Busy for End of Program Detection
- VPP Pin for Accelerated Program/Erase Operations
- $\overline{\text{RESET}}$ Input for Device Initialization
- Sector Lockdown Support
- TSOP and CBGA Package Options
- Top or Bottom Boot Block Configuration Available
- 128-bit Protection Register

Description

The AT49BV/LV16X4A(T) is a 2.65- to 3.3-volt 16-megabit Flash memory organized as 1,048,576 words of 16 bits each or 2,097,152 bytes of 8 bits each. The x16 data appears on I/O0 - I/O15; the x8 data appears on I/O0 - I/O7. The memory is divided into 39 sectors for erase operations. The device is offered in 48-lead TSOP and 48-ball CBGA packages. The device has $\overline{\text{CE}}$ and $\overline{\text{OE}}$ control signals to avoid any bus contention. This device can be read or reprogrammed using a single 2.65V power supply, making it ideally suited for in-system programming.

Pin Configurations

Pin Name	Function
A0 - A19	Addresses
$\overline{\text{CE}}$	Chip Enable
$\overline{\text{OE}}$	Output Enable
$\overline{\text{WE}}$	Write Enable
$\overline{\text{RESET}}$	Reset
RDY/ $\overline{\text{BUSY}}$	READY/ $\overline{\text{BUSY}}$ Output
VPP	Power Supply for Accelerated Program/Erase Operations
I/O0 - I/O14	Data Inputs/Outputs
I/O15 (A-1)	I/O15 (Data Input/Output, Word Mode) A-1 (LSB Address Input, Byte Mode)
$\overline{\text{BYTE}}$	Selects Byte or Word Mode
NC	No Connect
VCCQ	Output Power Supply



**16-megabit
(1M x 16/2M x 8)
3-volt Only
Flash Memory**

**AT49BV1604A
AT49BV1604AT
AT49BV1614A
AT49LV1614A
AT49BV1614AT
AT49LV1614AT**

Rev. 1411F-FLASH-03/02



TSOP Top View

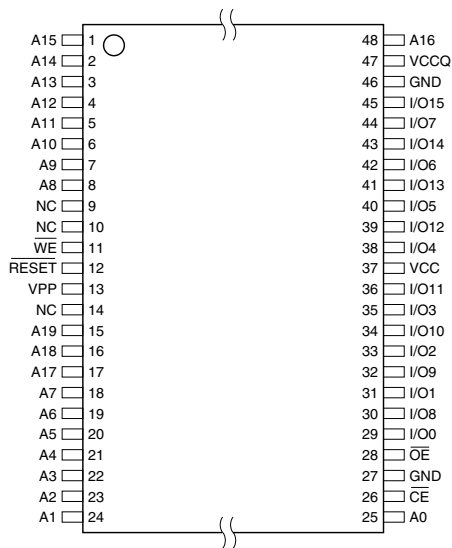

CBGA Top View (Ball Down)

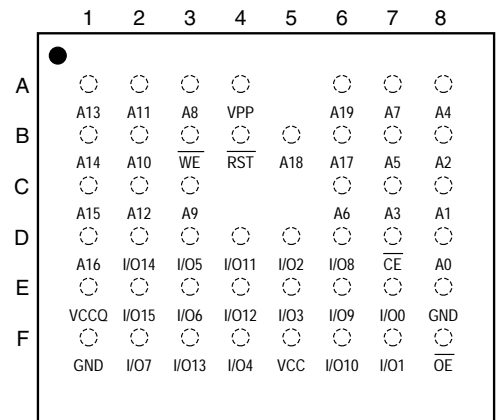

← AT49BV1604A(T) →

TSOP Top View
Type 1

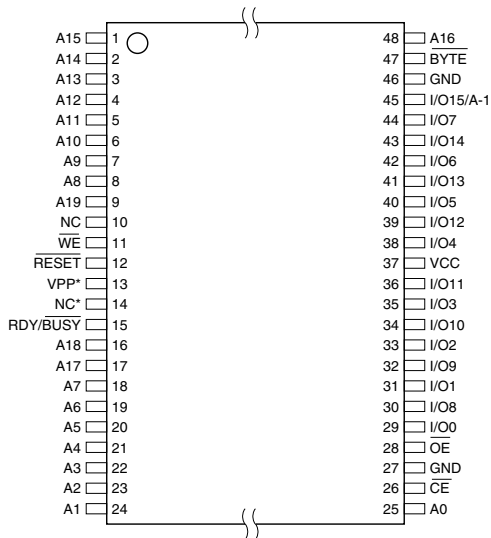

CBGA Top View

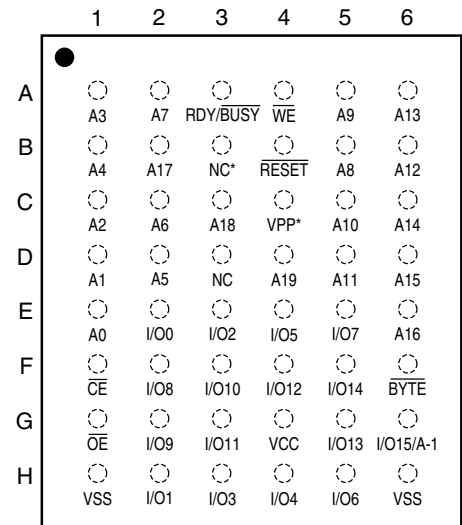

← AT49BV/LV1614A(T) →

Note: *For the AT49BV/LV1614A(T), either pin 13 or pin 14 (TSOP package) or ball B3 or ball C4 (CBGA package) can be connected to V_{PP} or both pins can be unconnected. Accelerated program/erase operations are only achieved if a voltage of $5V \pm 0.5V$ or $12V \pm 0.5V$ is applied to pin 13 (TSOP package) or ball C4 (CBGA package).

The device powers on in the read mode. Command sequences are used to place the device in other operation modes such as program and erase. The device has the capability to protect the data in any sector (see Sector Lockdown section).

The device is segmented into two memory planes. Reads from memory plane B may be performed even while program or erase functions are being executed in memory plane A and vice versa. This operation allows improved system performance by not requiring the system to wait for a program or erase operation to complete before a read is performed. To further increase the flexibility of the device, it contains an Erase Suspend feature. This feature will put the erase on hold for any amount of time and let the user read data from or program data to any of the remaining sectors within the same memory plane. There is no reason to suspend the erase operation if the data to be read is in the other memory plane. The end of a program or an erase cycle is detected by the Ready/ $\overline{\text{Busy}}$ pin, $\overline{\text{Data}}$ Polling or by the toggle bit.

The VPP pin provides faster program/erase times. With V_{PP} at 5.0V or 12.0V, the program and erase operations are accelerated.

A six-byte command (Enter Single Pulse Program Mode) sequence to remove the requirement of entering the three-byte program sequence is offered to further improve programming time. After entering the six-byte code, only single pulses on the write control lines are required for writing into the device. This mode (Single Pulse Byte/Word Program) is exited by powering down the device, or by pulsing the $\overline{\text{RESET}}$ pin low for a minimum of 500 ns and then bringing it back to V_{CC} . Erase and Erase Suspend/Resume commands will not work while in this mode; if entered they will result in data being programmed into the device. It is not recommended that the six-byte code reside in the software of the final product but only exist in external programming code.

When using the AT49BV1604A(T) pinout configuration, the device always operates in the word mode. In the AT49BV/LV1614A(T) configuration, the $\overline{\text{BYTE}}$ pin controls whether the device data I/O pins operate in the byte or word configuration. If the $\overline{\text{BYTE}}$ pin is set at logic "1", the device is in word configuration, I/O0 - I/O15 are active and controlled by $\overline{\text{CE}}$ and $\overline{\text{OE}}$.

If the $\overline{\text{BYTE}}$ pin is set at logic "0", the device is in byte configuration, and only data I/O pins I/O0 - I/O7 are active and controlled by $\overline{\text{CE}}$ and $\overline{\text{OE}}$. The data I/O pins I/O8 - I/O14 are tri-stated, and the I/O15 pin is used as an input for the LSB (A-1) address function.

Block Diagram

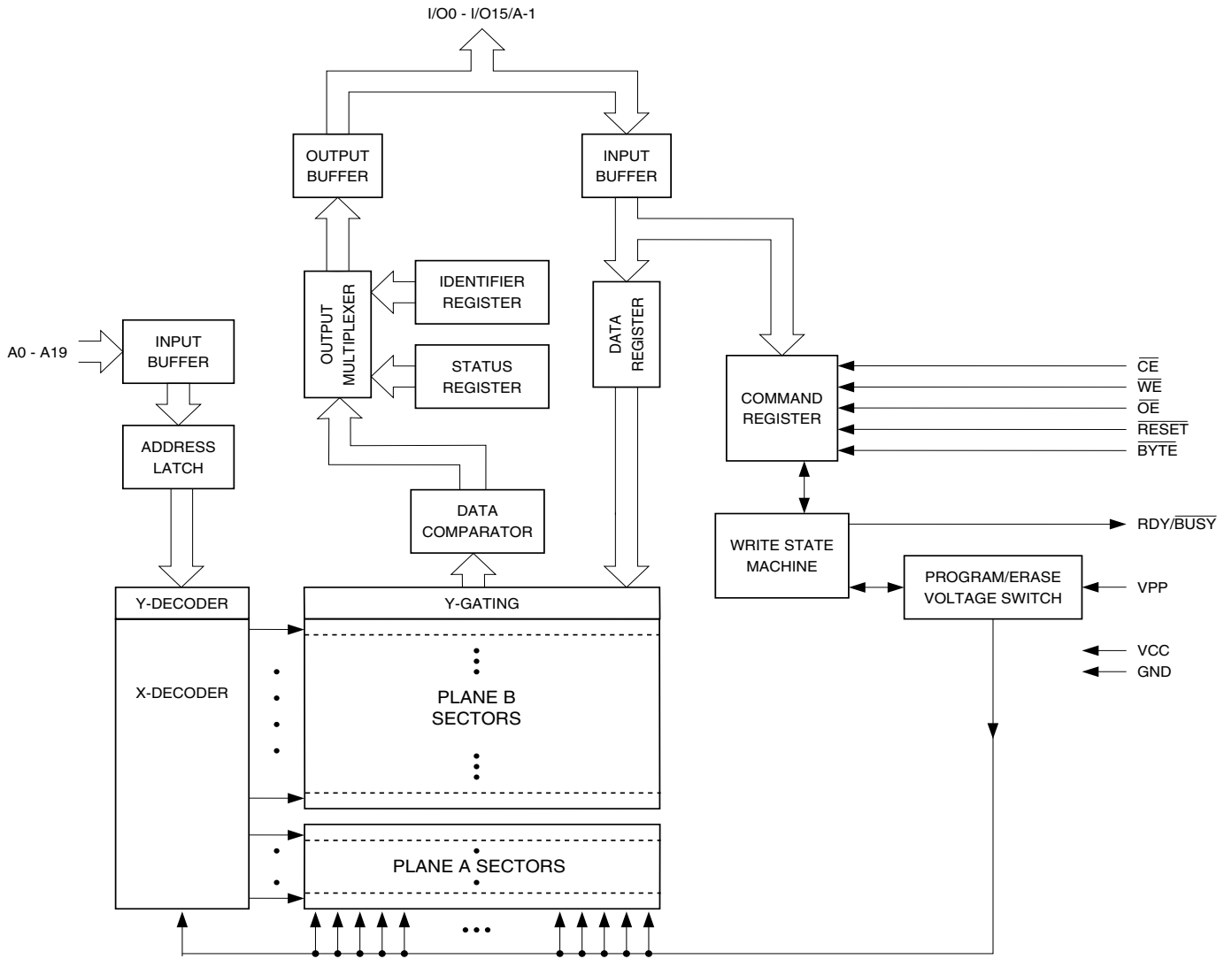

Device Operation

READ: The AT49BV/LV16X4A(T) is accessed like an EPROM. When \overline{CE} and \overline{OE} are low and \overline{WE} is high, the data stored at the memory location determined by the address pins are asserted on the outputs. The outputs are put in the high-impedance state whenever \overline{CE} or \overline{OE} is high. This dual-line control gives designers flexibility in preventing bus contention.

COMMAND SEQUENCES: When the device is first powered on it will be reset to the read or standby mode, depending upon the state of the control line inputs. In order to perform other device functions, a series of command sequences are entered into the device. The command sequences are shown in the Command Definitions table (I/O8 - I/O15 are don't care inputs for the command codes). The command sequences are written by applying a low pulse on the \overline{WE} or \overline{CE} input with \overline{CE} or \overline{WE} low (respectively) and \overline{OE} high. The address is latched on the falling edge of \overline{CE} or \overline{WE} , whichever occurs last. The data is latched by the first rising edge of \overline{CE} or \overline{WE} . Standard microprocessor write timings are used. The address locations used in the command sequences are not affected by entering the command sequences.

RESET: A \overline{RESET} input pin is provided to ease some system applications. When \overline{RESET} is at a logic high level, the device is in its standard operating mode. A low level on the \overline{RESET} input halts the present device operation and puts the outputs of the device in a high-impedance state. When a high level is reasserted on the \overline{RESET} pin, the device returns to the read or standby mode, depending upon the state of the control inputs.

ERASURE: Before a byte/word can be reprogrammed, it must be erased. The erased state of memory bits is a logical "1". The entire device can be erased by using the Chip Erase command or individual sectors can be erased by using the Sector Erase command.

CHIP ERASE: The entire device can be erased at one time by using the six-byte chip erase software code. After the chip erase has been initiated, the device will internally time the erase operation so that no external clocks are required. The maximum time to erase the chip is t_{EC} .

If the sector lockdown has been enabled, the chip erase will not erase the data in the sector that has been locked out; it will erase only the unprotected sectors. After the chip erase, the device will return to the read or standby mode.

SECTOR ERASE: As an alternative to a full chip erase, the device is organized into 39 sectors (SA0 - SA38) that can be individually erased. The Sector Erase command is a six-bus cycle operation. The sector address is latched on the falling \overline{WE} edge of the sixth cycle while the 30H data input command is latched on the rising edge of \overline{WE} . The sector erase starts after the rising edge of \overline{WE} of the sixth cycle. The erase operation is internally controlled; it will automatically time to completion. The maximum time to erase a section is t_{SEC} . When the sector programming lockdown feature is not enabled, the sector will erase (from the same Sector Erase command). An attempt to erase a sector that has been protected will result in the operation terminating in 2 μ s.

BYTE/WORD PROGRAMMING: Once a memory block is erased, it is programmed (to a logical "0") on a byte-by-byte or on a word-by-word basis. Programming is accomplished via the internal device command register and is a four-bus cycle operation. The device will automatically generate the required internal program pulses.

Any commands written to the chip during the embedded programming cycle will be ignored. If a hardware reset happens during programming, the data at the location being programmed will be corrupted. Please note that a data "0" cannot be programmed back to a "1"; only erase operations can convert "0"s to "1"s. Programming is completed after the specified t_{BP} cycle time. The \overline{Data} Polling feature or the Toggle Bit feature may be used to indicate the end of a program cycle.

VPP PIN: The circuitry of the AT49BV/LV16X4A(T) is designed so that the device can be programmed or erased from the V_{CC} power supply or from the VPP input pin. When V_{PP} is less than or equal to the V_{CC} pin, the device selects the V_{CC} supply for programming and erase



operations. When the VPP pin is greater than the V_{CC} supply, the device will select the V_{PP} input as the power supply for programming and erase operations. The device will allow for some variations between the V_{PP} input and the V_{CC} power supply in its selection of V_{CC} or V_{PP} for program or erase operations. If the VPP pin is within 0.3V of V_{CC} for 2.65V < V_{CC} < 3.3V, then the program or erase operations will use V_{CC} and disregard the V_{PP} input signal. When the V_{PP} signal is used to accelerate program and erase operations, the V_{PP} must be in the 5V ± 0.5V or 12V ± 0.5V range to ensure proper operation. The V_{pp} pin can be left unconnected.

SECTOR LOCKDOWN: Each sector has a programming lockdown feature. This feature prevents programming of data in the designated sectors once the feature has been enabled. These sectors can contain secure code that is used to bring up the system. Enabling the lockdown feature will allow the boot code to stay in the device while data in the rest of the device is updated. This feature does not have to be activated; any sector's usage as a write protected region is optional to the user.

At power-up or reset all sectors are unlocked. To activate the lockdown for a specific sector, the six-bus cycle Sector Lockdown command must be issued. Once a sector has been locked down, the contents of the sector is read-only and cannot be erased or programmed.

SECTOR LOCKDOWN DETECTION: A software method is available to determine if programming of a sector is locked down. When the device is in the software product identification mode (see Software Product Identification Entry and Exit sections) a read from address location 00002H within a sector will show if programming the sector is locked down. If the data on I/O0 is low, the sector can be programmed; if the data on I/O0 is high, the program lockdown feature has been enabled and the sector cannot be programmed. The software product identification exit code should be used to return to standard operation.

SECTOR LOCKDOWN OVERRIDE: The only way to unlock a sector that is locked down is through reset or power-up cycles. After power-up or reset, the content of a sector that is locked down can be erased and reprogrammed.

ERASE SUSPEND/ERASE RESUME: The Erase Suspend command allows the system to interrupt a sector erase operation and then program or read data from a different sector within the same plane. Since this device has a dual-plane architecture, there is no need to use the Erase Suspend feature while erasing a sector when you want to read data from a sector in the other plane. After the Erase Suspend command is given, the device requires a maximum time of 15 μs to suspend the erase operation. After the erase operation has been suspended, the plane that contains the suspended sector enters the erase-suspend-read mode. The system can then read data or program data to any other sector within the device. An address is not required during the Erase Suspend command. During a sector erase suspend, another sector cannot be erased. To resume the sector erase operation, the system must write the Erase Resume command. The Erase Resume command is a one-bus cycle command, which does require the plane address (determined by A18 and A19). The device also supports an erase suspend during a complete chip erase. While the chip erase is suspended, the user can read from any sector within the memory that is protected. The command sequence for a chip erase suspend and a sector erase suspend are the same.

PRODUCT IDENTIFICATION: The product identification mode identifies the device and manufacturer as Atmel. It may be accessed by hardware or software operation. The hardware operation mode can be used by an external programmer to identify the correct programming algorithm for the Atmel product.

For details, see "Operating Modes" on page 12 (for hardware operation) or "Software Product Identification Entry/Exit" on page 20. The manufacturer and device codes are the same for both modes.

128-BIT PROTECTION REGISTER: The AT49BV/LV16X4A(T) contains a 128-bit register that can be used for security purposes in system design. The protection register is divided into two 64-bit blocks. The two blocks are designated as block A and block B. The data in block A is non-changeable and is programmed at the factory with a unique number. The data in block B is programmed by the user and can be locked out such that data in the block cannot be reprogrammed. To program block B in the protection register, the four-bus cycle Program Protection Register command must be used as shown in the Command Definition table on page 8. To lock out block B, the four-bus cycle Lock Protection Register command must be used as shown in the Command Definition table. Data bit D1 must be zero during the fourth bus cycle. All other data bits during the fourth bus cycle are don't cares. Please see the "Protection Register Addressing Table" on page 9 for the address locations in the protection register. To read the protection register, the Product ID Entry command is given followed by a normal read operation from an address within the protection register. After reading the protection register, the Product ID Exit command must be given prior to performing any other operation.

DATA POLLING: The AT49BV/LV16X4A(T) features $\overline{\text{Data}}$ Polling to indicate the end of a program cycle. During a program cycle an attempted read of the last byte/word loaded will result in the complement of the loaded data on I/O7. Once the program cycle has been completed, true data is valid on all outputs and the next cycle may begin. During a chip or sector erase operation, an attempt to read the device will give a "0" on I/O7. Once the program or erase cycle has completed, true data will be read from the device. $\overline{\text{Data}}$ Polling may begin at any time during the program cycle. Please see "Status Bit Table" on page 21 for more details.

TOGGLE BIT: In addition to $\overline{\text{Data}}$ Polling, the AT49BV/LV16X4A(T) provides another method for determining the end of a program or erase cycle. During a program or erase operation, successive attempts to read data from the same memory plane will result in I/O6 toggling between one and zero. Once the program cycle has completed, I/O6 will stop toggling and valid data will be read. Examining the toggle bit may begin at any time during a program cycle.

An additional toggle bit is available on I/O2, which can be used in conjunction with the toggle bit that is available on I/O6. While a sector is erase suspended, a read or a program operation from the suspended sector will result in the I/O2 bit toggling. Please see "Status Bit Table" on page 21 for more details.

RDY/ $\overline{\text{BUSY}}$: For the AT49BV/LV1614A(T), an open-drain Ready/ $\overline{\text{Busy}}$ output pin provides another method of detecting the end of a program or erase operation. RDY/ $\overline{\text{BUSY}}$ is actively pulled low during the internal program and erase cycles and is released at the completion of the cycle. The open-drain connection allows for OR-tying of several devices to the same RDY/ $\overline{\text{BUSY}}$ line.

HARDWARE DATA PROTECTION: The Hardware Data Protection feature protects against inadvertent programs to the AT49BV/LV16X4A(T) in the following ways: (a) V_{CC} sense: if V_{CC} is below 1.8V (typical), the program function is inhibited. (b) V_{CC} power-on delay: once V_{CC} has reached the V_{CC} sense level, the device will automatically time out 10 ms (typical) before programming. (c) Program inhibit: holding any one of $\overline{\text{OE}}$ low, $\overline{\text{CE}}$ high or $\overline{\text{WE}}$ high inhibits program cycles. (d) Noise filter: pulses of less than 15 ns (typical) on the $\overline{\text{WE}}$ or $\overline{\text{CE}}$ inputs will not initiate a program cycle.

INPUT LEVELS: While operating with a 2.65V to 3.3V power supply, the address inputs and control inputs ($\overline{\text{OE}}$, $\overline{\text{CE}}$ and $\overline{\text{WE}}$) may be driven from 0 to 5.5V without adversely affecting the operation of the device. The I/O lines can only be driven from 0 to $V_{CC} + 0.6V$.

OUTPUT LEVELS: For the AT49BV1604A(T), output high levels (V_{OH}) are equal to $V_{CCQ} - 0.2V$ (not V_{CC}). For 2.65V - 3.3V output levels, V_{CCQ} must be tied to V_{CC} . For 1.8V - 2.2V output levels, V_{CCQ} must be regulated to $2.0V \pm 10\%$, while V_{CC} must be regulated to 2.65V - 3.0V (for minimum power).



Command Definition in Hex⁽¹⁾

Command Sequence	Bus Cycles	1st Bus Cycle		2nd Bus Cycle		3rd Bus Cycle		4th Bus Cycle		5th Bus Cycle		6th Bus Cycle	
		Addr	Data	Addr	Data	Addr	Data	Addr	Data	Addr	Data	Addr	Data
Read	1	Addr	D _{OUT}										
Chip Erase	6	555	AA	AAA ⁽²⁾	55	555	80	555	AA	AAA	55	555	10
Sector Erase	6	555	AA	AAA	55	555	80	555	AA	AAA	55	SA ⁽³⁾⁽⁴⁾	30
Byte/Word Program	4	555	AA	AAA	55	555	A0	Addr	D _{IN}				
Enter Single Pulse Program Mode	6	555	AA	AAA	55	555	80	555	AA	AAA	55	555	A0
Single Pulse Byte/Word Program	1	Addr	D _{IN}										
Sector Lockdown	6	555	AA	AAA	55	555	80	555	AA	AAA	55	SA ⁽³⁾⁽⁴⁾	60
Erase Suspend	1	XXX	B0										
Erase Resume	1	PA ⁽⁵⁾	30										
Product ID Entry	3	555	AA	AAA	55	555	90						
Product ID Exit ⁽⁶⁾	3	555	AA	AAA	55	555	F0						
Product ID Exit ⁽⁶⁾	1	XXX	F0										
Program Protection Register	4	555	AA	AAA	55	555	C0	Addr	D _{IN}				
Lock Protection Register - Block B	4	555	AA	AAA	55	555	C0	080	X0				
Status of Block B Protection	4	555	AA	AAA	55	555	90	80	D _{OUT} ⁽⁷⁾				

- Notes:
1. The DATA FORMAT shown for each bus cycle is as follows; I/O7 - I/O0 (Hex). In word operation I/O15 - I/O8 are Don't Care. The ADDRESS FORMAT shown for each bus cycle is as follows: A11 - A0 (Hex). Address A19 through A11 are Don't Care in the word mode. Address A19 through A11 are Don't Care in the byte mode.
 2. Since A11 is a Don't Care, AAA can be replaced with 2AA.
 3. SA = sector address. Any byte/word address within a sector can be used to designate the sector address (see pages 10 and 11 for details).
 4. Once a sector is in the lockdown mode, data in the protected sector cannot be changed unless the chip is reset or power cycled.
 5. PA is the plane address (A19-A18).
 6. Either one of the Product ID Exit commands can be used.
 7. If data bit D1 is "0", block B is locked. If data bit D1 is "1", block B can be reprogrammed.

Absolute Maximum Ratings*

Temperature under Bias	-55°C to +125°C
Storage Temperature	-65°C to +150°C
All Input Voltages (including NC Pins) with Respect to Ground	-0.6V to +6.25V
All Output Voltages with Respect to Ground	-0.6V to V _{CC} + 0.6V
Voltage on \overline{OE} and V _{PP} with Respect to Ground	-0.6V to +13.0V

*NOTICE: Stresses beyond those listed under "Absolute Maximum Ratings" may cause permanent damage to the device. This is a stress rating only and functional operation of the device at these or any other conditions beyond those indicated in the operational sections of this specification is not implied. Exposure to absolute maximum rating conditions for extended periods may affect device reliability.

Protection Register Addressing Table

Word	Use	Block	A7	A6	A5	A4	A3	A2	A1	A0
0	Factory	A	1	0	0	0	0	0	0	1
1	Factory	A	1	0	0	0	0	0	1	0
2	Factory	A	1	0	0	0	0	0	1	1
3	Factory	A	1	0	0	0	0	1	0	0
4	User	B	1	0	0	0	0	1	0	1
5	User	B	1	0	0	0	0	1	1	0
6	User	B	1	0	0	0	0	1	1	1
7	User	B	1	0	0	0	1	0	0	0

Note: 1. All address lines not specified in the above table must be 0 when accessing the protection register, i.e., A19 - A8 = 0.



AT49BV/LV1604A/1614A – Sector Address Table

Plane	Sector	Size (Bytes/Words)	x8	x16
			Address Range (A19 - A-1)	Address Range (A19 - A0)
A	SA0	8K/4K	000000 - 001FFF	00000 - 00FFF
A	SA1	8K/4K	002000 - 003FFF	01000 - 01FFF
A	SA2	8K/4K	004000 - 005FFF	02000 - 02FFF
A	SA3	8K/4K	006000 - 007FFF	03000 - 03FFF
A	SA4	8K/4K	008000 - 009FFF	04000 - 04FFF
A	SA5	8K/4K	00A000 - 00BFFF	05000 - 05FFF
A	SA6	8K/4K	00C000 - 00DFFF	06000 - 06FFF
A	SA7	8K/4K	00E000 - 00FFFF	07000 - 07FFF
A	SA8	64K/32K	010000 - 01FFFF	08000 - 0FFFF
A	SA9	64K/32K	020000 - 02FFFF	10000 - 17FFF
A	SA10	64K/32K	030000 - 03FFFF	18000 - 1FFFF
A	SA11	64K/32K	040000 - 04FFFF	20000 - 27FFF
A	SA12	64K/32K	050000 - 05FFFF	28000 - 2FFFF
A	SA13	64K/32K	060000 - 06FFFF	30000 - 37FFF
A	SA14	64K/32K	070000 - 07FFFF	38000 - 3FFFF
B	SA15	64K/32K	080000 - 08FFFF	40000 - 47FFF
B	SA16	64K/32K	090000 - 09FFFF	48000 - 4FFFF
B	SA17	64K/32K	0A0000 - 0AFFFF	50000 - 57FFF
B	SA18	64K/32K	0B0000 - 0BFFFF	58000 - 5FFFF
B	SA19	64K/32K	0C0000 - 0CFFFF	60000 - 67FFF
B	SA20	64K/32K	0D0000 - 0DFFFF	68000 - 6FFFF
B	SA21	64K/32K	0E0000 - 0EFFFF	70000 - 77FFF
B	SA22	64K/32K	0F0000 - 0FFFFF	78000 - 7FFFF
B	SA23	64K/32K	100000 - 10FFFF	80000 - 87FFF
B	SA24	64K/32K	110000 - 11FFFF	88000 - 8FFFF
B	SA25	64K/32K	120000 - 12FFFF	90000 - 97FFF
B	SA26	64K/32K	130000 - 13FFFF	98000 - 9FFFF
B	SA27	64K/32K	140000 - 14FFFF	A0000 - A7FFF
B	SA28	64K/32K	150000 - 15FFFF	A8000 - AFFFF
B	SA29	64K/32K	160000 - 16FFFF	B0000 - B7FFF
B	SA30	64K/32K	170000 - 1EFFFF	B8000 - F7FFF
B	SA31	64K/32K	180000 - 18FFFF	C0000 - C7FFF
B	SA32	64K/32K	190000 - 19FFFF	C8000 - CFFFF
B	SA33	64K/32K	1A0000 - 1AFFFF	D0000 - D7FFF
B	SA34	64K/32K	1B0000 - 1BFFFF	D8000 - DFFFF
B	SA35	64K/32K	1C0000 - 1CFFFF	E0000 - E7FFF
B	SA36	64K/32K	1D0000 - 1DFFFF	E8000 - EFFFF
B	SA37	64K/32K	1E0000 - 1EFFFF	F0000 - F7FFF
B	SA38	64K/32K	1F0000 - 1FFFFF	F8000 - FFFFF

AT49BV/LV1604AT/1614AT – Sector Address Table

Plane	Sector	Size (Bytes/Words)	x8 Address Range (A19 - A-1)	x16 Address Range (A19 - A0)
B	SA0	64K/32K	000000 - 00FFFF	00000 - 07FFF
B	SA1	64K/32K	010000 - 01FFFF	08000 - 0FFFF
B	SA2	64K/32K	020000 - 02FFFF	10000 - 17FFF
B	SA3	64K/32K	030000 - 03FFFF	18000 - 1FFFF
B	SA4	64K/32K	040000 - 04FFFF	20000 - 27FFF
B	SA5	64K/32K	050000 - 05FFFF	28000 - 2FFFF
B	SA6	64K/32K	060000 - 06FFFF	30000 - 37FFF
B	SA7	64K/32K	070000 - 07FFFF	38000 - 3FFFF
B	SA8	64K/32K	080000 - 08FFFF	40000 - 47FFF
B	SA9	64K/32K	090000 - 09FFFF	48000 - 4FFFF
B	SA10	64K/32K	0A0000 - 0AFFFF	50000 - 57FFF
B	SA11	64K/32K	0B0000 - 0BFFFF	58000 - 5FFFF
B	SA12	64K/32K	0C0000 - 0CFFFF	60000 - 67FFF
B	SA13	64K/32K	0D0000 - 0DFFFF	68000 - 6FFFF
B	SA14	64K/32K	0E0000 - 0EFFFF	70000 - 77FFF
B	SA15	64K/32K	0F0000 - 0FFFFF	78000 - 7FFFF
B	SA16	64K/32K	100000 - 10FFFF	80000 - 87FFF
B	SA17	64K/32K	110000 - 11FFFF	88000 - 8FFFF
B	SA18	64K/32K	120000 - 12FFFF	90000 - 97FFF
B	SA19	64K/32K	130000 - 13FFFF	98000 - 9FFFF
B	SA20	64K/32K	140000 - 14FFFF	A0000 - A7FFF
B	SA21	64K/32K	150000 - 15FFFF	A8000 - AFFFF
B	SA22	64K/32K	160000 - 16FFFF	B0000 - B7FFF
B	SA23	64K/32K	170000 - 17FFFF	B8000 - BFFFF
A	SA24	64K/32K	180000 - 18FFFF	C0000 - C7FFF
A	SA25	64K/32K	190000 - 19FFFF	C8000 - CFFFF
A	SA26	64K/32K	1A0000 - 1AFFFF	D0000 - D7FFF
A	SA27	64K/32K	1B0000 - 1BFFFF	D8000 - DFFFF
A	SA28	64K/32K	1C0000 - 1CFFFF	E0000 - E7FFF
A	SA29	64K/32K	1D0000 - 1DFFFF	E8000 - EFFFF
A	SA30	64K/32K	1E0000 - 1EFFFF	F0000 - F7FFF
A	SA31	8K/4K	1F0000 - 1F1FFF	F8000 - F8FFF
A	SA32	8K/4K	1F2000 - 1F3FFF	F9000 - F9FFF
A	SA33	8K/4K	1F4000 - 1F5FFF	FA000 - FAFFF
A	SA34	8K/4K	1F6000 - 1F7FFF	FB000 - FBFFF
A	SA35	8K/4K	1F8000 - 1F9FFF	FC000 - FCFFF
A	SA36	8K/4K	1FA000 - 1FBFFF	FD000 - FDFFF
A	SA37	8K/4K	1FC000 - 1FDFFF	FE000 - FEFFF
A	SA38	8K/4K	1FE000 - 1FFFFF	FF000 - FFFFF





DC and AC Operating Range

		AT49BV/LV16X4A(T)-70	AT49BV/LV16X4A(T)-90
Operating Temperature (Case)	Ind.	-40°C - 85°C	-40°C - 85°C
V _{CC} Power Supply		2.65V to 3.3V/3.0V to 3.6V	2.65V to 3.3V/3.0V to 3.6V

Operating Modes

Mode	\overline{CE}	\overline{OE}	\overline{WE}	\overline{RESET}	V _{PP}	Ai	I/O
Read	V _{IL}	V _{IL}	V _{IH}	V _{IH}	X	Ai	D _{OUT}
Program/Erase ⁽²⁾	V _{IL}	V _{IH}	V _{IL}	V _{IH}	V _{PP} ⁽⁶⁾	Ai	D _{IN}
Standby/Program Inhibit	V _{IH}	X ⁽¹⁾	X	V _{IH}	X	X	High-Z
Program Inhibit	X	X	V _{IH}	V _{IH}	X		
	X	V _{IL}	X	V _{IH}	X		
Output Disable	X	V _{IH}	X	V _{IH}	X		High-Z
Reset	X	X	X	V _{IL}	X	X	High-Z
Product Identification							
Hardware	V _{IL}	V _{IL}	V _{IH}	V _{IH}		A1 - A19 = V _{IL} , A9 = V _H ⁽³⁾ , A0 = V _{IL}	Manufacturer Code ⁽⁴⁾
						A1 - A19 = V _{IL} , A9 = V _H ⁽³⁾ , A0 = V _{IH}	Device Code ⁽⁴⁾
Software ⁽⁵⁾				V _{IH}		A0 = V _{IL} , A1 - A19 = V _{IL}	Manufacturer Code ⁽⁴⁾
						A0 = V _{IH} , A1 - A19 = V _{IL}	Device Code ⁽⁴⁾

- Notes:
- X can be V_{IL} or V_{IH}.
 - Refer to AC programming waveforms on page 19.
 - V_H = 12.0V ± 0.5V.
 - Manufacturer Code: 1FH (x8); 001FH (x16), Device Code: C0H (x8)-AT49BV/LV16X4A; 00C0H (x16)-AT49BV/LV16X4A; C2H (x8)-AT49BV/LV16X4AT; 00C2H (x16)-AT49BV/LV16X4AT.
 - See details under "Software Product Identification Entry/Exit" on page 20.
 - V_{PP} can be left unconnected or 0V ≤ V_{PP} ≤ 3.3V. For faster erase/program operations, V_{PP} can be set to 5.0V ± 0.5V or 12V ± 0.5V.

DC Characteristics

Symbol	Parameter	Condition	Min	Max	Units
I_{LI}	Input Load Current	$V_{IN} = 0V$ to V_{CC}		10	μA
I_{LO}	Output Leakage Current	$V_{I/O} = 0V$ to V_{CC}		10	μA
I_{SB1}	V_{CC} Standby Current CMOS	$\overline{CE} = V_{CC} - 0.3V$ to V_{CC}		10	μA
I_{SB2}	V_{CC} Standby Current TTL	$\overline{CE} = 2.0V$ to V_{CC}		1	mA
I_{SB3}	V_{CC} Standby Current TTL	$\overline{CE} = 2.0V$ to V_{CC} , $V_{CC} = 2.85V$		10	μA
$I_{CC}^{(1)(2)}$	V_{CC} Active Read Current	$f = 5$ MHz; $I_{OUT} = 0$ mA, $3.3V \leq V_{CC}$		30	mA
I_{CC1}	V_{CC} Programming Current ($V_{PP} = V_{CC}$)			45	mA
I_{PP1}	V_{PP} Input Load Current	$V_{PP} = 0V$, $V_{CC} = 3.0V$		10	μA
		$V_{PP} = V_{CC} = 3.0V$		10	μA
I_{CC2}	V_{CC} Programming Current ($V_{PP} = 5.0V \pm 0.5V$)			40	mA
I_{PP2}	V_{PP} Programming Current ($V_{PP} = 5.0V \pm 0.5V$)			5	mA
I_{CC3}	V_{CC} Programming Current ($V_{PP} = 12.0V \pm 0.5V$)			40	mA
I_{PP3}	V_{PP} Programming Current ($V_{PP} = 12.0V \pm 0.5V$)			6	mA
V_{IL}	Input Low Voltage			0.6	V
V_{IH}	Input High Voltage		2.0		V
V_{OL1}	Output Low Voltage	$I_{OL} = 2.1$ mA		0.45	V
V_{OL2}	Output Low Voltage	$I_{OL} = 1.0$ mA		0.20	V
V_{OH1}	Output High Voltage	$I_{OH} = -400$ μA $V_{CCQ} < 2.6V$	$V_{CCQ} - 0.2$ [AT49BV1604A(T)]		V
		$I_{OH} = -400$ μA $V_{CCQ} \geq 2.6V$	2.4 [AT49BV1604A(T)]		V
		$I_{OH} = -400$ μA	2.4 [AT49BV/LV1614A(T)]		V
V_{OH2}	Output High Voltage	$I_{OH} = -100$ μA $V_{CCQ} < 2.6V$	$V_{CCQ} - 0.1$ [AT49BV1604A(T)]		V
		$I_{OH} = -100$ μA $V_{CCQ} \geq 2.6V$	2.5 [AT49BV1604A(T)]		V
		$I_{OH} = -100$ μA	2.5 [AT49BV/LV1614A(T)]		V

- Note:
1. In the erase mode, I_{CC} is 50 mA.
 2. For $3.3V < V_{CC} < 3.6V$, I_{CC} (max) = 35 mA.

AC Read Characteristics

Symbol	Parameter	AT49BV/LV16X4A(T)-70		AT49BV/LV16X4A(T)-90		Units
		Min	Max	Min	Max	
t_{ACC}	Address to Output Delay		70		90	ns
$t_{CE}^{(1)}$	\overline{CE} to Output Delay		70		90	ns
$t_{OE}^{(2)}$	\overline{OE} to Output Delay	0	35	0	40	ns
$t_{DF}^{(3)(4)}$	\overline{CE} or \overline{OE} to Output Float	0	25	0	25	ns
t_{OH}	Output Hold from \overline{OE} , \overline{CE} or Address, whichever occurred first	0		0		ns
t_{RO}	\overline{RESET} to Output Delay		100		100	ns

AC Read Waveforms⁽¹⁾⁽²⁾⁽³⁾⁽⁴⁾

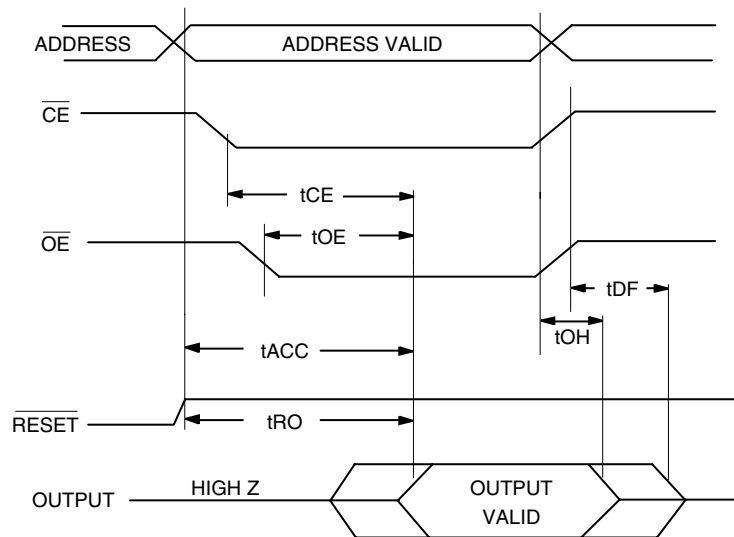

1. \overline{CE} may be delayed up to $t_{ACC} - t_{CE}$ after the address transition without impact on t_{ACC} .
2. \overline{OE} may be delayed up to $t_{CE} - t_{OE}$ after the falling edge of \overline{CE} without impact on t_{CE} or by $t_{ACC} - t_{OE}$ after an address change without impact on t_{ACC} .
3. t_{DF} is specified from \overline{OE} or \overline{CE} , whichever occurs first (CL = 5 pF).
4. This parameter is characterized and is not 100% tested.

Input Test Waveforms and Measurement Level

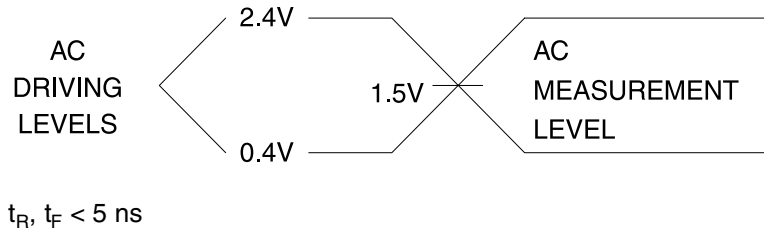

Output Test Load

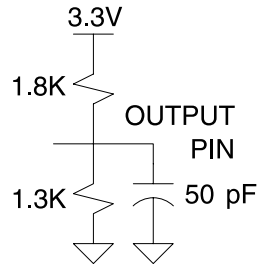

Pin Capacitance

$f = 1 \text{ MHz}, T = 25^\circ\text{C}^{(1)}$

Symbol	Typ	Max	Units	Conditions
C_{IN}	4	6	pF	$V_{IN} = 0V$
C_{OUT}	8	12	pF	$V_{OUT} = 0V$

Note: 1. This parameter is characterized and is not 100% tested.

AC Byte/Word Load Characteristics

Symbol	Parameter	Min	Max	Units
t_{AS}, t_{OES}	Address, \overline{OE} Setup Time	0		ns
t_{AH}	Address Hold Time	40		ns
t_{CS}	Chip Select Setup Time	0		ns
t_{CH}	Chip Select Hold Time	0		ns
t_{WP}	Write Pulse Width (\overline{WE} or \overline{CE})	40		ns
t_{DS}	Data Setup Time	30		ns
t_{DH}, t_{OEH}	Data, \overline{OE} Hold Time	0		ns
t_{WPH}	Write Pulse Width High	30		ns

AC Byte/Word Load Waveforms

\overline{WE} Controlled

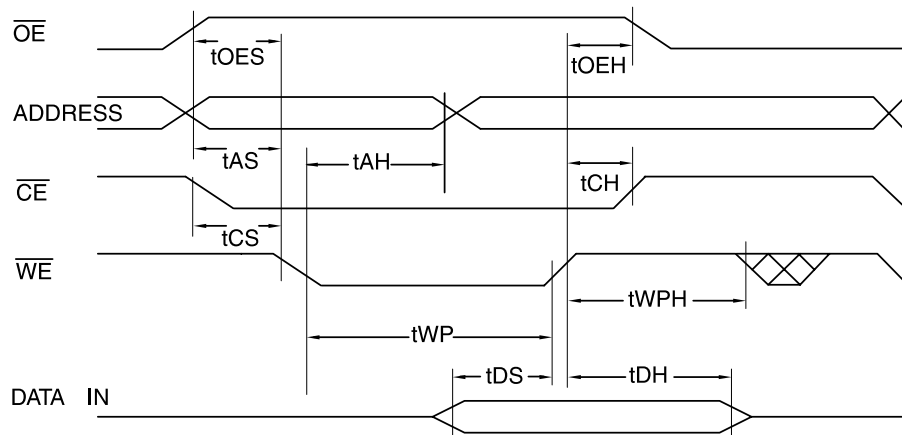

\overline{CE} Controlled

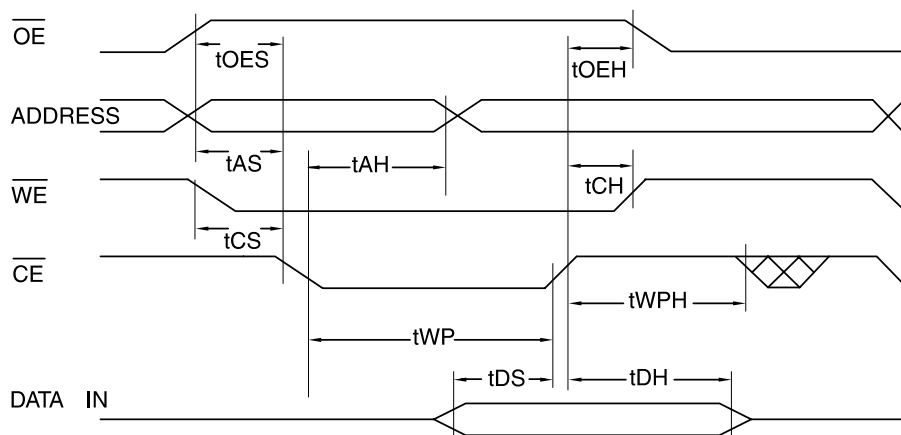

Program Cycle Characteristics

Symbol	Parameter	Min	Typ	Max	Units
t_{BP}	Byte/Word Programming Time ($0V < V_{PP} < 4.5V$)		20	50	μs
t_{BPVPP}	Byte/Word Programming Time ($V_{PP} \geq 4.5V$)		10	25	μs
t_{AS}	Address Setup Time	0			ns
t_{AH}	Address Hold Time	40			ns
t_{DS}	Data Setup Time	30			ns
t_{DH}	Data Hold Time	0			ns
t_{WP}	Write Pulse Width	40			ns
t_{WPH}	Write Pulse Width High	30			ns
t_{WC}	Write Cycle Time	70			ns
$t_{SR/W}$	Latency between Read and Write Operations	50			ns
t_{RP}	Reset Pulse Width	500			ns
t_{RH}	Reset High Time before Read	50			ns
t_{EC}	Chip Erase Cycle Time ($V_{PP} < 4.5V$)			12	seconds
t_{ECVPP}	Chip Erase Cycle Time ($V_{PP} \geq 4.5V$)			6	seconds
t_{SEC}	Sector Erase Cycle Time ($V_{PP} < 4.5V$)		300	400	ms
t_{EPS}	Erase or Program Suspend Time			15	μs

Program Cycle Waveforms

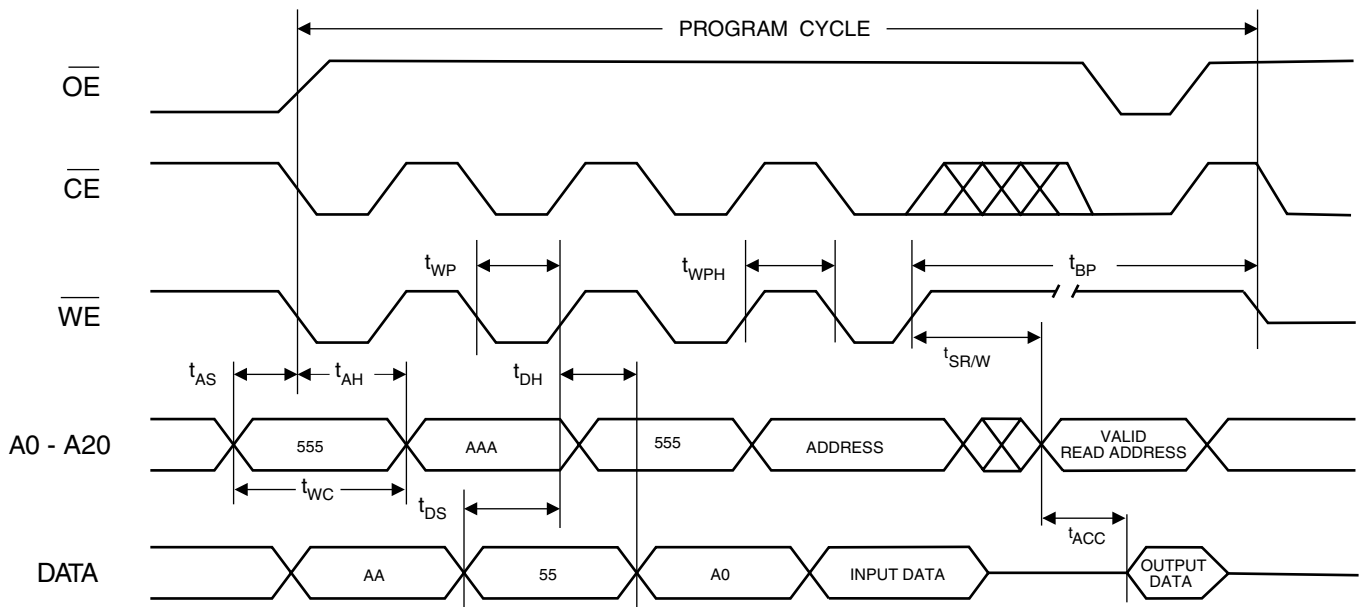

Sector or Chip Erase Cycle Waveforms

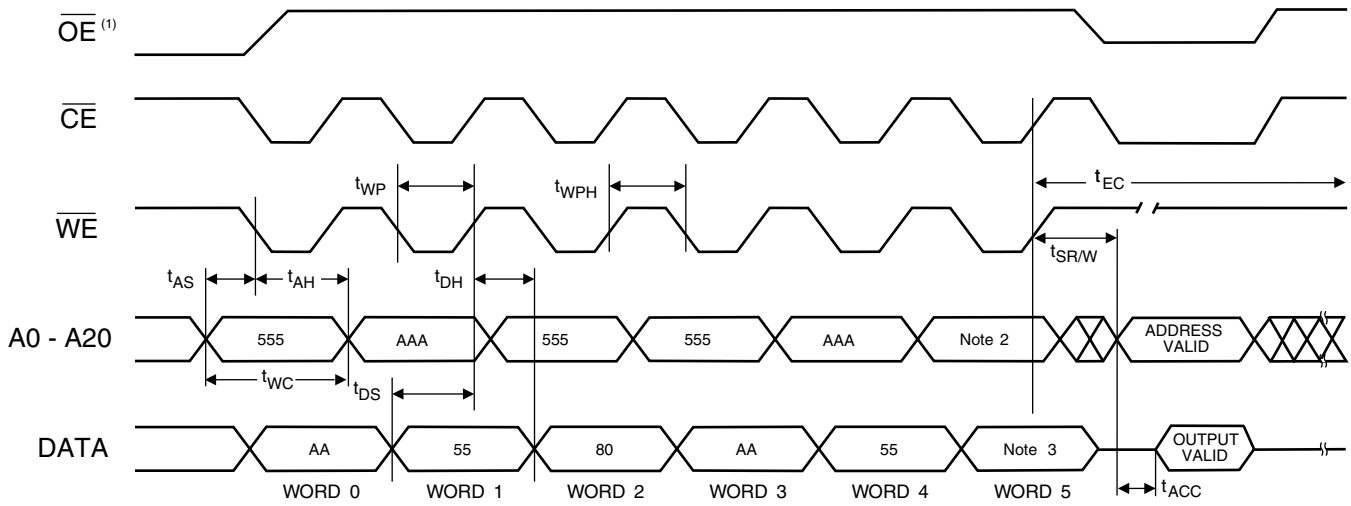

- Notes:
1. \overline{OE} must be high only when \overline{WE} and \overline{CE} are both low.
 2. For chip erase, the address should be 555. For sector erase, the address depends on what sector is to be erased. (See note 3 under Command Definitions.)
 3. For chip erase, the data should be 10H, and for sector erase, the data should be 30H.

Data Polling Characteristics⁽¹⁾

Symbol	Parameter	Min	Typ	Max	Units
t_{DH}	Data Hold Time	10			ns
$t_{OE\overline{H}}$	\overline{OE} Hold Time	10			ns
t_{OE}	\overline{OE} to Output Delay ⁽²⁾				ns
t_{WR}	Write Recovery Time	0			ns

Notes: 1. These parameters are characterized and not 100% tested.
 2. See t_{OE} spec in "AC Read Characteristics" on page 14.

Data Polling Waveforms

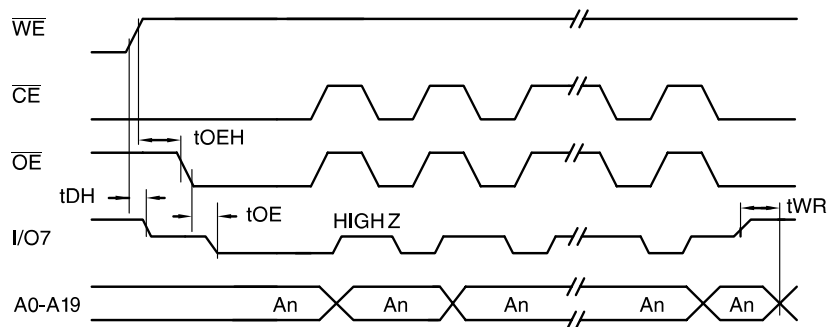

Toggle Bit Characteristics⁽¹⁾

Symbol	Parameter	Min	Typ	Max	Units
t_{DH}	Data Hold Time	10			ns
$t_{OE\overline{H}}$	\overline{OE} Hold Time	10			ns
t_{OE}	\overline{OE} to Output Delay ⁽²⁾				ns
t_{OEHP}	\overline{OE} High Pulse	50			ns
t_{WR}	Write Recovery Time	0			ns

Notes: 1. These parameters are characterized and not 100% tested.
 2. See t_{OE} spec in "AC Read Characteristics" on page 14.

Toggle Bit Waveforms⁽¹⁾⁽²⁾⁽³⁾

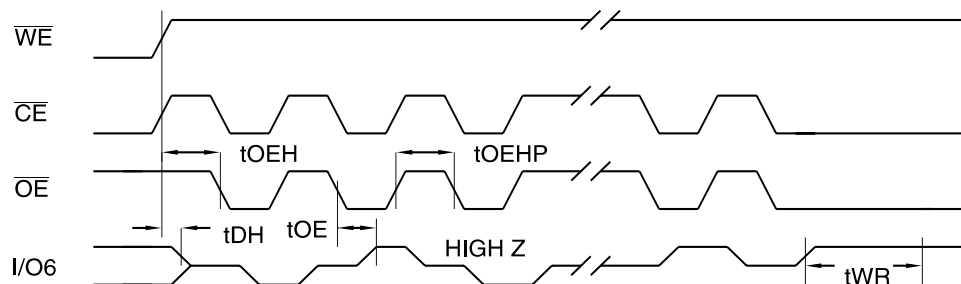

Notes: 1. Toggling either \overline{OE} or \overline{CE} or both \overline{OE} and \overline{CE} will operate toggle bit.
 The t_{OEHP} specification must be met by the toggling input(s).
 2. Beginning and ending state of I/O6 will vary.
 3. Any address location may be used but the address should not vary.

Software Product Identification Entry⁽¹⁾

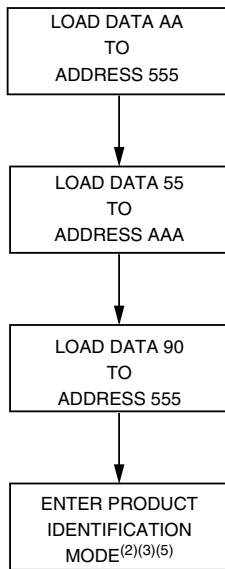

Sector Lockdown Enable Algorithm⁽¹⁾

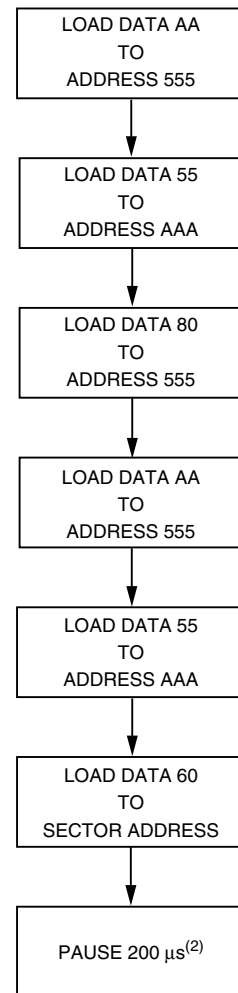

Software Product Identification Exit⁽¹⁾⁽⁶⁾

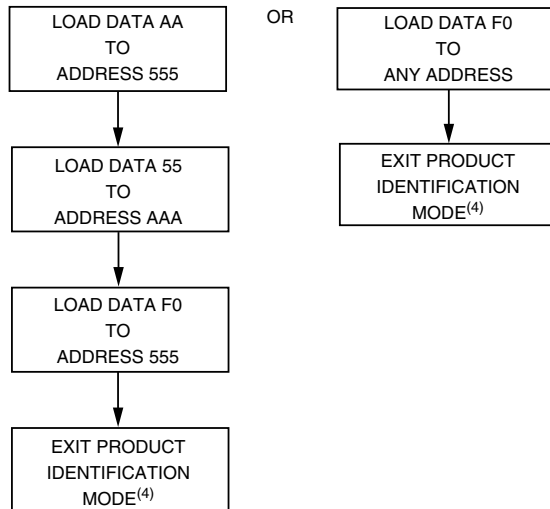

- Notes:
1. Data Format: I/O15 - I/O8 (Don't Care); I/O7 - I/O0 (Hex)
Address Format: A11 - A0 (Hex), A-1, and A11 - A19 (Don't Care).
 2. Sector Lockdown feature enabled.

- Notes:
1. Data Format: I/O15 - I/O8 (Don't Care); I/O7 - I/O0 (Hex)
Address Format: A11 - A0 (Hex), A-1, and A11 - A19 (Don't Care).
 2. A1 - A19 = V_{IL}. Manufacturer Code is read for A0 = V_{IL}; Device Code is read for A0 = V_{IH}.
Additional Device Code is read for address 0003H
 3. The device does not remain in identification mode if powered down.
 4. The device returns to standard operation mode.
 5. Manufacturer Code: 1FH(x8); 001FH(x16)
Device Code: C0H (x8) - AT49BV/LV16X4A;
00C0H (x16) - AT49BV/LV16X4A;
C2H (x8) - AT49BV/LV16X4AT;
00C2H (x16) - AT49BV/LV16X4AT.
Additional Device Code: C8H (x8) - AT49BV/LV16X4A(T)
00C8H (x16) - AT49BV/LV16X4A(T)
 6. Either one of the Product ID Exit commands can be used.

Status Bit Table

	Status Bit					
	I/O7		I/O6		I/O2	
	Plane A	Plane B	Plane A	Plane B	Plane A	Plane B
Read Address In						
While						
Programming in Plane A	$\overline{I/O7}$	DATA	TOGGLE	DATA	1	DATA
Programming in Plane B	DATA	$\overline{I/O7}$	DATA	TOGGLE	DATA	1
Erasing in Plane A	0	DATA	TOGGLE	DATA	TOGGLE	DATA
Erasing in Plane B	DATA	0	DATA	TOGGLE	DATA	TOGGLE
Erase Suspended & Read Erasing Sector	1	1	1	1	TOGGLE	TOGGLE
Erase Suspended & Read Non-erasing Sector	DATA	DATA	DATA	DATA	DATA	DATA
Erase Suspended & Program Non-erasing Sector in Plane A	$\overline{I/O7}$	DATA	TOGGLE	DATA	TOGGLE	DATA
Erase Suspended & Program Non-erasing Sector in Plane B	DATA	$\overline{I/O7}$	DATA	TOGGLE	DATA	TOGGLE



AT49BV1604A(T)/1614A(T) Ordering Information

t _{ACC} (ns)	I _{CC} (mA)		Ordering Code	Package	Operation Range
	Active	Standby			
70	25	0.01	AT49BV1604A-70CI AT49BV1604A-70TI	45C1 48T	Industrial (-40° to 85°C)
90	25	0.01	AT49BV1604A-90CI AT49BV1604A-90TI	45C1 48T	Industrial (-40° to 85°C)
70	25	0.01	AT49BV1604AT-70CI AT49BV1604AT-70TI	45C1 48T	Industrial (-40° to 85°C)
90	25	0.01	AT49BV1604AT-90CI AT49BV1604AT-90TI	45C1 48T	Industrial (-40° to 85°C)
70	25	0.01	AT49BV1614A-70CI AT49BV1614A-70TI	48C5 48T	Industrial (-40° to 85°C)
90	25	0.01	AT49BV1614A-90CI AT49BV1614A-90TI	48C5 48T	Industrial (-40° to 85°C)
70	25	0.01	AT49BV1614AT-70CI AT49BV1614AT-70TI	48C5 48T	Industrial (-40° to 85°C)
90	25	0.01	AT49BV1614AT-90CI AT49BV1614AT-90TI	48C5 48T	Industrial (-40° to 85°C)

AT49LV1614A(T) Ordering Information

t _{ACC} (ns)	I _{CC} (mA)		Ordering Code	Package	Operation Range
	Active	Standby			
70	25	0.01	AT49LV1614A-70CI AT49LV1614A-70TI	48C5 48T	Industrial (-40° to 85°C)
70	25	0.01	AT49LV1614AT-70CI AT49LV1614AT-70TI	48C5 48T	Industrial (-40° to 85°C)

Package Type	
45C1	45-ball, Plastic Chip-size Ball Grid Array Package (CBGA)
48C5	48-ball, Plastic Chip-size Ball Grid Array Package (CBGA)
48T	48-lead, Plastic Thin Small Outline Package (TSOP)

Packaging Information

45C1 – CBGA

Dimensions in Millimeters and (Inches).
Controlling dimension: millimeters.

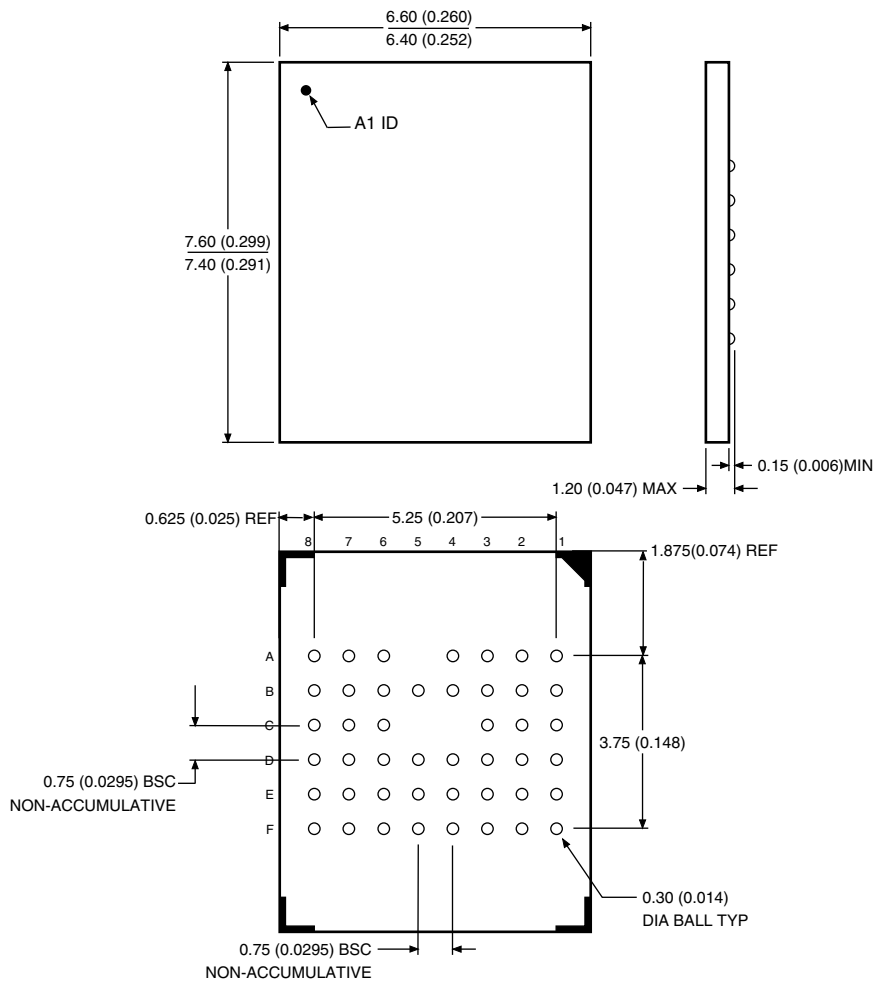

4/11/01



2325 Orchard Parkway
San Jose, CA 95131

TITLE

45C1, 45-ball (8 x 6 Array), 0.75 mm Pitch, 6.5 x 7.5 x 1.2 mm
Chip-scale Ball Grid Array Package (CBGA)

DRAWING NO.

45C1

REV.

A



48C5 – CBGA

Dimensions in Millimeters and (Inches).
Controlling dimension: millimeters.

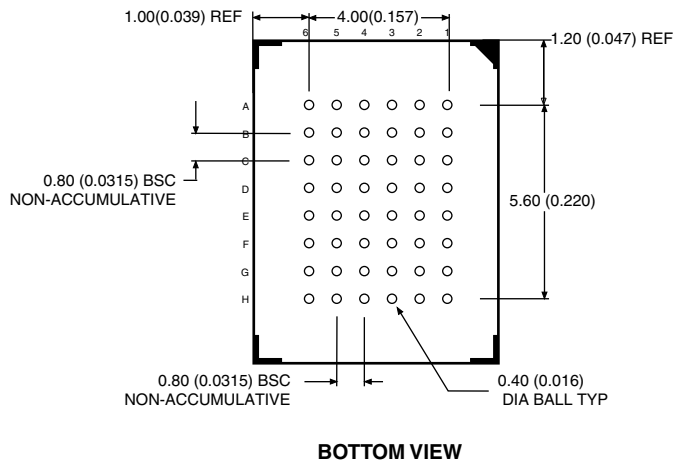
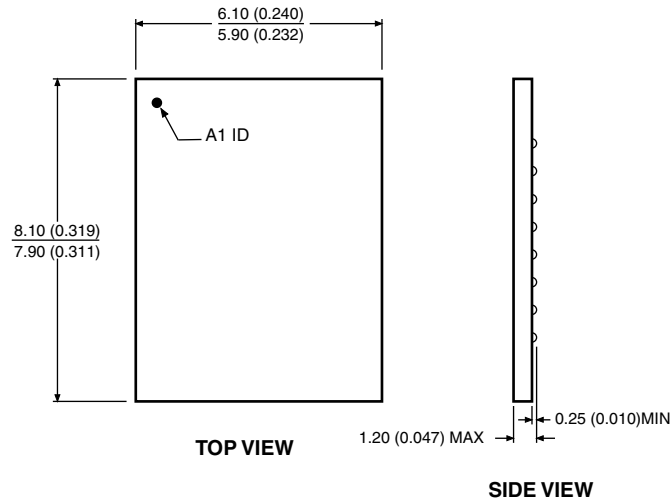

10/18/01



2325 Orchard Parkway
San Jose, CA 95131

TITLE

48C5, 48-ball (6 x 8 Array), 0.80 mm Pitch, 6 x 8 x 1.2 mm
Chip-scale Ball Grid Array Package (CBGA)

DRAWING NO.

48C5

REV.

A

48T – TSOP

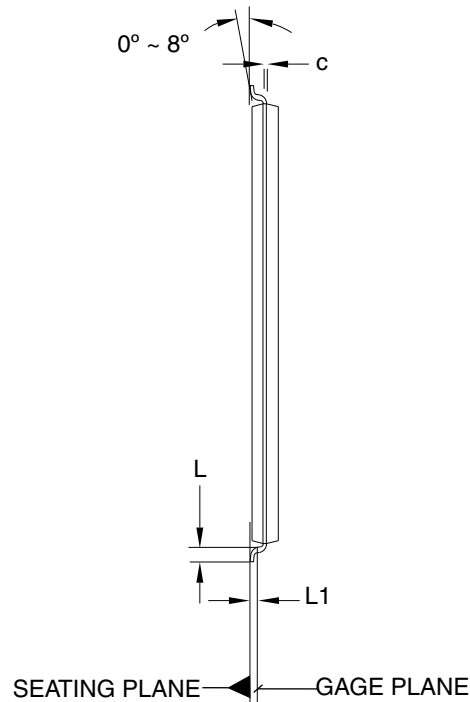
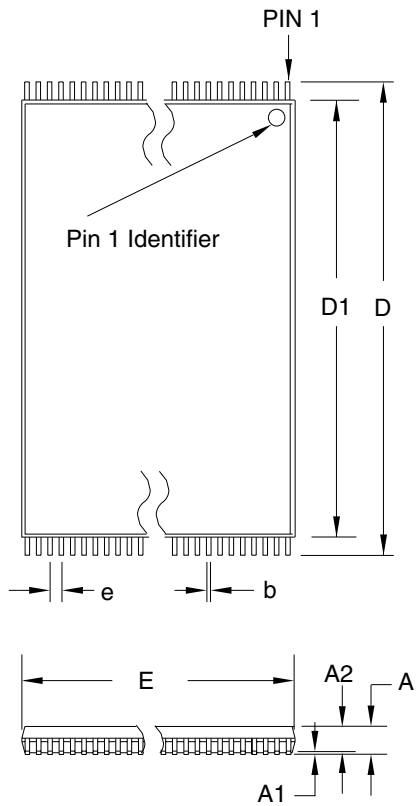

COMMON DIMENSIONS
(Unit of Measure = mm)

SYMBOL	MIN	NOM	MAX	NOTE
A	–	–	1.20	
A1	0.05	–	0.15	
A2	0.95	1.00	1.05	
D	19.80	20.00	20.20	
D1	18.30	18.40	18.50	Note 2
E	11.90	12.00	12.10	Note 2
L	0.50	0.60	0.70	
L1	0.25 BASIC			
b	0.17	0.22	0.27	
c	0.10	–	0.21	
e	0.50 BASIC			

- Notes:
1. This package conforms to JEDEC reference MO-142, Variation DD.
 2. Dimensions D1 and E do not include mold protrusion. Allowable protrusion on E is 0.15 mm per side and on D1 is 0.25 mm per side.
 3. Lead coplanarity is 0.10 mm maximum.

10/18/01



2325 Orchard Parkway
San Jose, CA 95131

TITLE

48T, 48-lead (12 x 20 mm Package) Plastic Thin Small Outline Package, Type I (TSOP)

DRAWING NO.

48T

REV.

B





Atmel Headquarters

Corporate Headquarters

2325 Orchard Parkway
San Jose, CA 95131
TEL 1(408) 441-0311
FAX 1(408) 487-2600

Europe

Atmel SarL
Route des Arsenaux 41
Casa Postale 80
CH-1705 Fribourg
Switzerland
TEL (41) 26-426-5555
FAX (41) 26-426-5500

Asia

Atmel Asia, Ltd.
Room 1219
Chinachem Golden Plaza
77 Mody Road Tsimhatsui
East Kowloon
Hong Kong
TEL (852) 2721-9778
FAX (852) 2722-1369

Japan

Atmel Japan K.K.
9F, Tonetsu Shinkawa Bldg.
1-24-8 Shinkawa
Chuo-ku, Tokyo 104-0033
Japan
TEL (81) 3-3523-3551
FAX (81) 3-3523-7581

Atmel Operations

Memory

Atmel Corporate
2325 Orchard Parkway
San Jose, CA 95131
TEL 1(408) 436-4270
FAX 1(408) 436-4314

Microcontrollers

Atmel Corporate
2325 Orchard Parkway
San Jose, CA 95131
TEL 1(408) 436-4270
FAX 1(408) 436-4314

Atmel Nantes
La Chantrerie
BP 70602
44306 Nantes Cedex 3, France
TEL (33) 2-40-18-18-18
FAX (33) 2-40-18-19-60

ASIC/ASSP/Smart Cards

Atmel Rousset
Zone Industrielle
13106 Rousset Cedex, France
TEL (33) 4-42-53-60-00
FAX (33) 4-42-53-60-01

Atmel Colorado Springs
1150 East Cheyenne Mtn. Blvd.
Colorado Springs, CO 80906
TEL 1(719) 576-3300
FAX 1(719) 540-1759

Atmel Smart Card ICs
Scottish Enterprise Technology Park
Maxwell Building
East Kilbride G75 0QR, Scotland
TEL (44) 1355-803-000
FAX (44) 1355-242-743

RF/Automotive

Atmel Heilbronn
Theresienstrasse 2
Postfach 3535
74025 Heilbronn, Germany
TEL (49) 71-31-67-0
FAX (49) 71-31-67-2340

Atmel Colorado Springs
1150 East Cheyenne Mtn. Blvd.
Colorado Springs, CO 80906
TEL 1(719) 576-3300
FAX 1(719) 540-1759

Biometrics/Imaging/Hi-Rel MPU/ High Speed Converters/RF Datacom

Atmel Grenoble
Avenue de Rochepleine
BP 123
38521 Saint-Egreve Cedex, France
TEL (33) 4-76-58-30-00
FAX (33) 4-76-58-34-80

e-mail

literature@atmel.com

Web Site

<http://www.atmel.com>

© Atmel Corporation 2002.

Atmel Corporation makes no warranty for the use of its products, other than those expressly contained in the Company's standard warranty which is detailed in Atmel's Terms and Conditions located on the Company's web site. The Company assumes no responsibility for any errors which may appear in this document, reserves the right to change devices or specifications detailed herein at any time without notice, and does not make any commitment to update the information contained herein. No licenses to patents or other intellectual property of Atmel are granted by the Company in connection with the sale of Atmel products, expressly or by implication. Atmel's products are not authorized for use as critical components in life support devices or systems.

ATMEL® is the registered trademark of Atmel.

Other terms and product names may be the trademarks of others.



Printed on recycled paper.

Looking for pricing, stock, or lifecycle information?

Click below to explore more details on WIN SOURCE:

 [View AT49BV1614A-90TI on WIN SOURCE](#)

 [Microchip Technology](#) Information

Optimize Your Supply Chain with WIN SOURCE Solutions

-  Global Sourcing Solution
-  Obsolete Management
-  Cost Control Management
-  Shortage Management
-  Alternative Solution
-  Excess Inventory Management