



**THE DATASHEET OF  
AT43USB380E-AC**



## Description

The AT43USB380 is a straightforward upgrade of the AT43USB370 Host/Function Processor to support the USB 2.0 On-The-Go (OTG) specification. It can operate either as a single-chip Host/Function Processor or if used in conjunction with an external Atmel Charge Pump, as a full OTG solution.

The AT43USB380 is functionally equivalent to the AT43USB370 as a Host/Function Processor and can be used in place of the AT43USB370 in the existing AT43USB370 design with minor hardware modifications. The pinout differences between the AT43USB370 and the AT43USB380 are due to the inclusion of the on-chip OTG interface in the AT43USB380.

To support OTG functionality, an external Charge Pump has to be connected to the OTG interface of the AT43USB380, as shown in Figure 1 on page 7. The external Charge Pump serves in the following two capacities:

1. As a power source to the downstream USB devices.
2. As a signaling interface during the OTG session negotiation upon connection.

From the hardware standpoint, the AT43USB380 is equivalent to the AT43USB370 with the following exceptions:

- **On-chip OTG Interface.** This hardware block is added to the AT43USB380 to support the OTG functionality. Signals in the OTG interface include ID, DISCHARGE, PUMP, CONTROL, EN, SESS\_VLD, SESS\_END, SESS\_HIGH and SESS\_LOW. This interface is used during an OTG session to determine the roles of the AT43USB380 and the connected OTG-enabled USB device either as a host or a function.
- **8/16/32 Bit Generic Host Processor Interface.** The AT43USB380 has a variable width, generic host processor interface whereas the AT43USB370 supports only 32-bit host interface. The width of the host interface on the AT43USB380 is determined by firmware configuration.
- **Simplified System Interface.** The GPIOs required in AT43USB370 for handshaking are no longer required in AT43USB380. The system processor can write directly to the AT43USB380 registers thus eliminates the need for PROG, SEL, READY, DONE, MORE, INTR\_IN signals. The WAIT\_N signal is not needed either. It is only there for precaution for SYS\_CLK synchronization.
- **Up to 16 GPIO Pins.** GPIO pins are multiplexed with the host processor interface. When the interface to the host processor is 8 or 16 bits, up to 16 of the unused pins in the host processor interface can be used as GPIO pins. High level APIs are provided to access these GPIO pins.

From the standpoint of the firmware development environment, the AT43USB380 shares the same high level APIs and low level firmware libraries with the AT43USB370. Additions to the AT43USB380 firmware suite include:

- High level APIs specific to the OTG support. The number of additional APIs is less than 10.
- Low level OTG firmware embedded in the AT43USB380 hardware that support Host Negotiation Protocol (HNP) and Session Request Protocol (SRP).

The AT43USB380 share the same debugging tools with the AT43USB370 as well. During development, the AT43USB380 should be treated as a black box in terms of



## On-The-Go Upgrade of the AT43USB370 USB 2.0 Full-Speed Host/Function Processor

### AT43USB380

## Upgrade Map Summary

3420AS-USB-03/04



Note: This is a summary document. A complete document is not available at this time. For more information, please contact your local Atmel sales office.



USB functionality. Communication with the AT43USB380 is achieved through a small set (less than 25) of high level, ANSI C-compliant APIs. The actual USB protocol including HNP and SRP is transparent to the host processor.

## AT43USB380 OTG Processor Pin Description

Table 1 gives the description of the pins.

**Table 1.** Pin Description of the AT43USB380

| Signal Name                  | Dir. | Polarity | Width | Description  |
|------------------------------|------|----------|-------|--|
| <b>System Interface</b>      |      |          |       |  |
| SYS_CLK                      | I    |          | 1     | Host system clock input for synchronization of WAIT_N and DREQ_N. (Synchronization requirement can be enable/disable through internal register settings) |
| A[7:0]                       | I    |          | 8     | System Address Bus   |
| CS_N                         | I    | LO       | 1     | CHIP_SELECT signal from System (ARM®)  |
| D[15:0]                      | B    |          | 16    | System Data Bus [15:0]   |
| D[31:16]/<br>GPIO[15:0]      | B    |          | 16    | BWIDTH[1:0]=1x : System Data Bus [31:16]<br>BWIDTH[1:0]=0x : GPIO[15:0]  |
| DACK_N                       | I    | LO       | 1     | DMA Acknowledge from System (ARM)  |
| DREQ_N                       | O    | LO       | 1     | DMA Request to System (ARM)  |
| INTR_OUT                     | O    | HI       | 1     | Interrupt to System (ARM)  |
| OE_N                         | I    | LO       | 1     | OUTPUT_ENABLE from System (ARM)  |
| WAIT_N                       | O    | LO       | 1     | WAIT to System (ARM)   |
| WE_N                         | I    | LO       | 1     | WRITE_ENABLE from System (ARM)   |
| BWIDTH[1:0]                  | I    |          | 2     | System Data Bus Size:<br>00 : 8 Bit Interface D[7:0]<br>01 : 16 Bit Interface D[15:0]<br>1x : 32 Bit Interface D[31:0]                                   |
| WAKEUP_N                     | I    | LO       | 1     | Wakeup Request from System   |
| <b>USB Interface</b>         |      |          |       |  |
| DM                           | B    |          | 1     | USB Line (D-)  |
| DP                           | B    |          | 1     | USB Line (D+)  |
| ID                           | I    |          | 1     | OTG device type identification; used to differentiate a Mini-A and Mini-B plug   |
| RPU_EN                       | O    |          | 1     | Enable resistive pull-up to the D+ line  |
| RPD_EN                       | O    |          | 1     | Enable resistive pull-down to the D+/D- lines  |
| <b>Charge Pump Interface</b> |      |          |       |  |
| CPClk                        | O    |          | 1     | Charge Pump clock output   |
| EN                           | O    |          | 1     | Charge Pump; Enable for Charge Pump  |
| PUMP_EN                      | O    |          | 1     | Charge Pump; Enable for Charge Pump  |

# AT43USB380 Upgrade Map Summary

**Table 1.** Pin Description of the AT43USB380 (Continued)

| Signal Name               | Dir. | Polarity | Width | Description  |
|---------------------------|------|----------|-------|--|
| SESS_VLD                  | I    |          | 1     | Charge Pump; Active high when VBUS > VSESS_VLD otherwise "0"                                       |
| SESS_END                  | I    |          | 1     | Charge Pump; Active high when VBUS > VSESS_END otherwise "0"                                       |
| SESS_LOW                  | I    |          | 1     | Charge Pump; Active high when VBUS > VSESS_LOW otherwise "0"                                       |
| SESS_HIGH                 | I    |          | 1     | Charge Pump; Active high when VBUS > VSESS_HIGH otherwise "0"                                      |
| LOW_CUR                   | O    |          | 1     | Limits the current output of the Charge Pump. Used during VBUS pulsing when configured as B-device |
| DISCHARGE                 | O    |          | 1     | Charge Pump; Connect VBUS to ground  |
| <b>Oscillator, Clocks</b> |      |          |       |  |
| XTAL1                     | I    |          | 1     | Oscillator input   |
| XTAL2                     | O    |          | 1     | Oscillator output  |
| LFT                       | I    |          | 1     | PLL loop filter  |
| CLK_SEL                   | I    |          | 1     | Clock Source selection between crystal and external oscillator                                     |
| RESET_N                   | I    | LO       | 1     | RESET for USB Processor  |
| <b>Jtag Interface</b>     |      |          |       |  |
| TCK/SI                    | I    |          | 1     | TP3=0: JTAG Clock - from JTAG controller;<br>TP3=1: SI-EEPROM                                      |
| TDI/SCK                   | I    |          | 1     | TP3=0: JTAG Serial Data IN - from JTAG controller;<br>TP3=1: SCK-EEPROM                            |
| TDO/SO                    | O    |          | 1     | TP3=0: JTAG Serial Data OUT - from JTAG controller;<br>TP3=1: SO-EEPROM                            |
| TMS/CS                    | I    |          | 1     | TP3=0: JTAG Mode Select - from JTAG controller;<br>TP3=1: CS-EEPROM                                |
| TRST_N                    | I    | LO       | 1     | JTAG Reset - from JTAG controller  |
| <b>Test Pins</b>          |      |          |       |  |
| TP0                       | I    |          | 1     | Test pin 0   |
| TP1                       | I    |          | 1     | Test Pin 1   |
| TP2                       | I    |          | 1     | Test pin 2   |
| TP3                       | I    |          | 1     | Test pin 3   |
| TP4/SCAN_EN               | I    |          | 1     | Test pin 4/SCAN_EN   |
| TP_CLK<br>/D_CLK          | O    |          | 1     | Clock test output/SIE DPLL extracted clock   |
| TP_RCV_DATA<br>/RCV_DATA  | O    |          | 1     | Extracted serial data test output  |



**Table 1.** Pin Description of the AT43USB380 (Continued)

| Signal Name              | Dir. | Polarity | Width | Description           |
|--------------------------|------|----------|-------|-----------------------|
| <b>Power/Ground Pins</b> |      |          |       |                       |
| VEXT18                   | O    |          | 3     | 1.8V regulated output |
| VDD                      | I    |          | 5     | 3.3V input            |
| VSS                      |      |          | 10    | Ground                |

## AT43USB380 OTG Processor Pin Assignment

| Pin # | Signal    | Type                |
|-------|-----------|---------------------|
| 1     | A7        | Input               |
| 2     | A6        | Input               |
| 3     | A5        | Input               |
| 4     | A4        | Input               |
| 5     | A3        | Input               |
| 6     | A2        | Input               |
| 7     | A1        | Input               |
| 8     | A0        | Input               |
| 9     | CS_N      | Input               |
| 10    | OE_N      | Input               |
| 11    | WE_N      | Input               |
| 12    | INTR_OUT  | Output              |
| 13    | VSS       | Power Supply/Ground |
| 14    | VDD18     | Power Supply/Ground |
| 15    | VDD       | Power Supply/Ground |
| 16    | SYS_CLK   | Input               |
| 17    | WAIT_N    | Output              |
| 18    | DREQ_N    | Output              |
| 19    | DACK_N    | Input               |
| 20    | CPClk     | Output              |
| 21    | DISCHARGE | Output              |
| 22    | EN        | Output              |
| 23    | LOW_CUR   | Output              |
| 24    | PUMP_EN   | Output              |
| 25    | SESS_LOW  | Input               |
| 26    | VSS       | Power Supply/Ground |
| 27    | SESS_VLD  | Input               |
| 28    | SESS_HIGH | Input               |
| 29    | SESS_END  | Input               |

# AT43USB380 Upgrade Map Summary

| Pin # | Signal               | Type                |
|-------|----------------------|---------------------|
| 30    | ID                   | Input               |
| 31    | TP0                  | Input               |
| 32    | TP1                  | Input               |
| 33    | CLK_SEL              | Input               |
| 34    | VSS                  | Power Supply/Ground |
| 35    | XTAL1                | Input               |
| 36    | XTAL2                | Output              |
| 37    | LFT                  | Input               |
| 38    | VDD18                | Power Supply/Ground |
| 39    | VDD                  | Power Supply/Ground |
| 40    | VSS                  | Power Supply/Ground |
| 41    | DM                   | Bi-directional      |
| 42    | DP                   | Bi-directional      |
| 43    | TP2                  | Input               |
| 44    | TP3                  | Input               |
| 45    | RPD_EN               | Output              |
| 46    | RPU_EN               | Output              |
| 47    | RESET_N              | Input               |
| 48    | TCK/SI               | Input               |
| 49    | TMS/CS               | Input               |
| 50    | VDD                  | Power Supply/Ground |
| 51    | VSS                  | Power Supply/Ground |
| 52    | TDI/SCK              | Input               |
| 53    | TDO/SO               | Output              |
| 54    | TRST_N               | Input               |
| 55    | TP_CLK/D_CLK         | Output              |
| 56    | TP_RCV_DATA/RCV_DATA | Output              |
| 57    | TP4/scan_en          | Input               |
| 58    | BWIDTH[0]            | Input               |
| 59    | WAKEUP_N             | Input               |
| 60    | D31/GPIO[15]         | Bi-directional      |
| 61    | D30/GPIO[14]         | Bi-directional      |
| 62    | D29/GPIO[13]         | Bi-directional      |
| 63    | D28/GPIO[12]         | Bi-directional      |
| 64    | VSS                  | Power Supply/Ground |
| 65    | VDD18                | Power Supply/Ground |
| 66    | VDD                  | Power Supply/Ground |



| Pin # | Signal       | Type                |
|-------|--------------|---------------------|
| 67    | D27/GPIO[11] | Bi-directional      |
| 68    | D26/GPIO[10] | Bi-directional      |
| 69    | D25/GPIO[9]  | Bi-directional      |
| 70    | D24/GPIO[8]  | Bi-directional      |
| 71    | D23/GPIO[7]  | Bi-directional      |
| 72    | D22/GPIO[6]  | Bi-directional      |
| 73    | D21/GPIO[5]  | Bi-directional      |
| 74    | D20/GPIO[4]  | Bi-directional      |
| 75    | VDD          | Power Supply/Ground |
| 76    | VSS          | Power Supply/Ground |
| 77    | D19/GPIO[3]  | Bi-directional      |
| 78    | D18/GPIO[2]  | Bi-directional      |
| 79    | D17/GPIO[1]  | Bi-directional      |
| 80    | D16/GPIO[0]  | Bi-directional      |
| 81    | BWIDTH[1]    | Input               |
| 82    | D15          | Bi-directional      |
| 83    | D14          | Bi-directional      |
| 84    | D13          | Bi-directional      |
| 85    | D12          | Bi-directional      |
| 86    | D11          | Bi-directional      |
| 87    | VDD          | Power Supply/Ground |
| 88    | VSS          | Power Supply/Ground |
| 89    | D10          | Bi-directional      |
| 90    | D9           | Bi-directional      |
| 91    | D8           | Bi-directional      |
| 92    | D7           | Bi-directional      |
| 93    | D6           | Bi-directional      |
| 94    | D5           | Bi-directional      |
| 95    | VSS          | Power Supply/Ground |
| 96    | D4           | Bi-directional      |
| 97    | D3           | Bi-directional      |
| 98    | D2           | Bi-directional      |
| 99    | D1           | Bi-directional      |
| 100   | D0           | Bi-directional      |

## USB-OTG Interface Connections for Host Mode

Figure 1. AT43USB380 USB and Charge Pump Connection for Host Mode

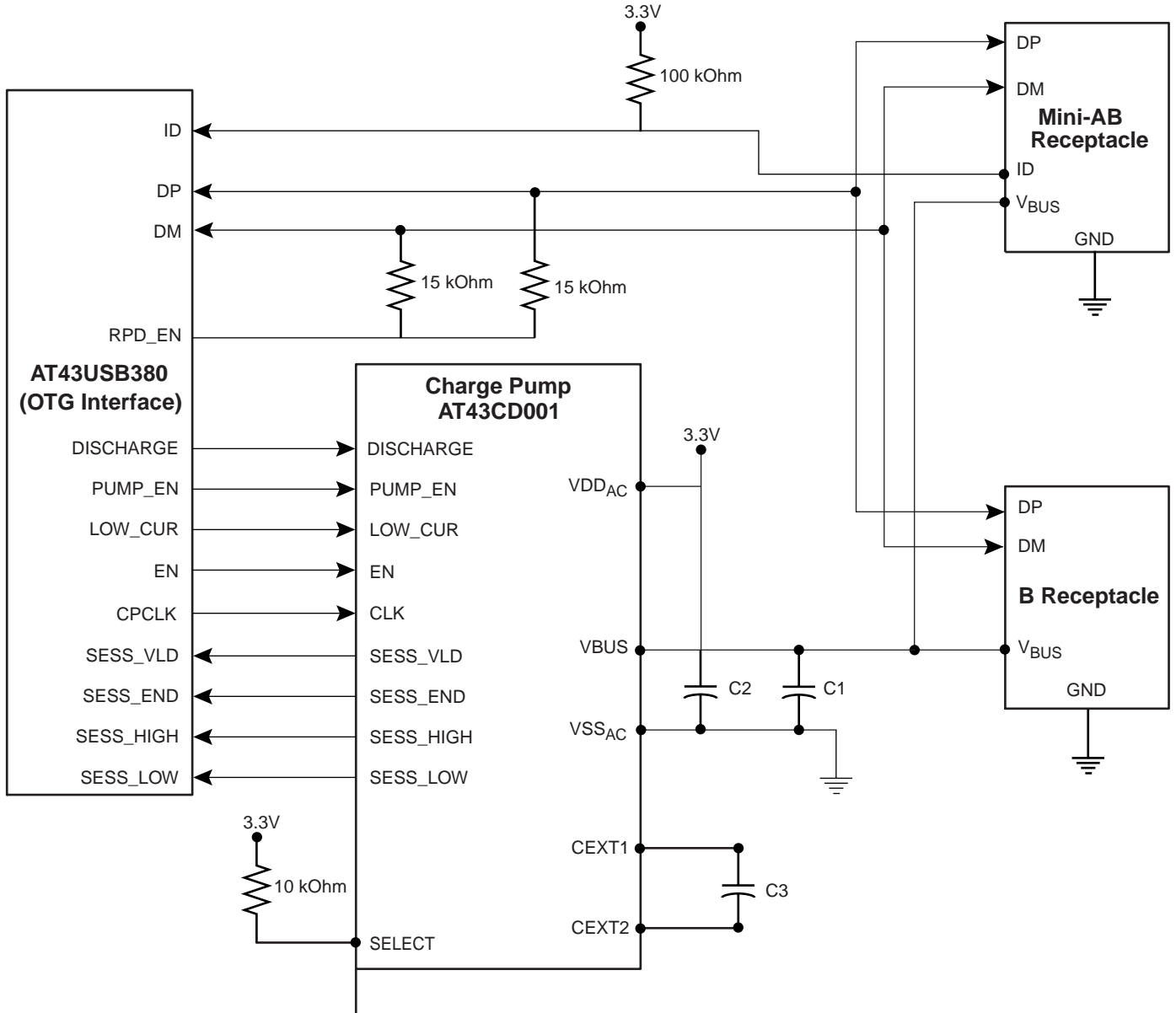



## Atmel Corporation

2325 Orchard Parkway  
San Jose, CA 95131, USA  
Tel: 1(408) 441-0311  
Fax: 1(408) 487-2600

## Regional Headquarters

### Europe

Atmel Sarl  
Route des Arsenalux 41  
Case Postale 80  
CH-1705 Fribourg  
Switzerland  
Tel: (41) 26-426-5555  
Fax: (41) 26-426-5500

### Asia

Room 1219  
Chinachem Golden Plaza  
77 Mody Road Tsimshatsui  
East Kowloon  
Hong Kong  
Tel: (852) 2721-9778  
Fax: (852) 2722-1369

### Japan

9F, Tonetsu Shinkawa Bldg.  
1-24-8 Shinkawa  
Chuo-ku, Tokyo 104-0033  
Japan  
Tel: (81) 3-3523-3551  
Fax: (81) 3-3523-7581

## Atmel Operations

### Memory

2325 Orchard Parkway  
San Jose, CA 95131, USA  
Tel: 1(408) 441-0311  
Fax: 1(408) 436-4314

### Microcontrollers

2325 Orchard Parkway  
San Jose, CA 95131, USA  
Tel: 1(408) 441-0311  
Fax: 1(408) 436-4314

La Chantrerie  
BP 70602  
44306 Nantes Cedex 3, France  
Tel: (33) 2-40-18-18-18  
Fax: (33) 2-40-18-19-60

### ASIC/ASSP/Smart Cards

Zone Industrielle  
13106 Rousset Cedex, France  
Tel: (33) 4-42-53-60-00  
Fax: (33) 4-42-53-60-01

1150 East Cheyenne Mtn. Blvd.  
Colorado Springs, CO 80906, USA  
Tel: 1(719) 576-3300  
Fax: 1(719) 540-1759

Scottish Enterprise Technology Park  
Maxwell Building  
East Kilbride G75 0QR, Scotland  
Tel: (44) 1355-803-000  
Fax: (44) 1355-242-743

### RF/Automotive

Theresienstrasse 2  
Postfach 3535  
74025 Heilbronn, Germany  
Tel: (49) 71-31-67-0  
Fax: (49) 71-31-67-2340

1150 East Cheyenne Mtn. Blvd.  
Colorado Springs, CO 80906, USA  
Tel: 1(719) 576-3300  
Fax: 1(719) 540-1759

### Biometrics/Imaging/Hi-Rel MPU/ High Speed Converters/RF Datacom

Avenue de Rochepleine  
BP 123  
38521 Saint-Egreve Cedex, France  
Tel: (33) 4-76-58-30-00  
Fax: (33) 4-76-58-34-80

---

### Literature Requests

[www.atmel.com/literature](http://www.atmel.com/literature)

**Disclaimer:** Atmel Corporation makes no warranty for the use of its products, other than those expressly contained in the Company's standard warranty which is detailed in Atmel's Terms and Conditions located on the Company's web site. The Company assumes no responsibility for any errors which may appear in this document, reserves the right to change devices or specifications detailed herein at any time without notice, and does not make any commitment to update the information contained herein. No licenses to patents or other intellectual property of Atmel are granted by the Company in connection with the sale of Atmel products, expressly or by implication. Atmel's products are not authorized for use as critical components in life support devices or systems.

© Atmel Corporation 2003. All rights reserved. Atmel® and combinations thereof, are the registered trademarks of Atmel Corporation or its subsidiaries. ARM® is the registered trademark of ARM Limited. Other terms and product names may be the trademarks of others.



Printed on recycled paper.

3420AS-USB-03/04

## Looking for pricing, stock, or lifecycle information?

Click below to explore more details on WIN SOURCE:

- ⊖ [View AT43USB380E-AC on WIN SOURCE](#)
- ⊖ [Microchip Technology](#) Information

## Optimize Your Supply Chain with WIN SOURCE Solutions

- ✓ Global Sourcing Solution
- ✓ Obsolete Management
- ✓ Cost Control Management
- ✓ Shortage Management
- ✓ Alternative Solution
- ✓ Excess Inventory Management