



**THE DATASHEET OF
AS5600-SO_EK_AB**



AS5600

12-Bit Programmable Contactless Potentiometer

General Description

The AS5600 is an easy to program magnetic rotary position sensor with a high-resolution 12-bit analog or PWM output. This contactless system measures the absolute angle of a diametric magnetized on-axis magnet. This AS5600 is designed for contactless potentiometer applications and its robust design eliminates the influence of any homogenous external stray magnetic fields.

The industry-standard I²C interface supports simple user programming of non-volatile parameters without requiring a dedicated programmer.

By default the output represents a range from 0 to 360 degrees. It is also possible to define a smaller range to the output by programming a zero angle (start position) and a maximum angle (stop position).

The AS5600 is also equipped with a smart low power mode feature to automatically reduce the power consumption.

An input pin (DIR) selects the polarity of the output with regard to rotation direction. If DIR is connected to ground, the output value increases with clockwise rotation. If DIR is connected to VDD, the output value increases with counterclockwise rotation.

Ordering Information and Content Guide appear at end of datasheet.

Key Benefits & Features

The benefits and features of AS5600, 12-bit Programmable Contactless Potentiometer are listed below:

Figure 1:
Added Value of Using AS5600

Benefits	Features
<ul style="list-style-type: none"> Highest reliability and durability 	<ul style="list-style-type: none"> Contactless angle measurement
<ul style="list-style-type: none"> Simple programming 	<ul style="list-style-type: none"> Simple user-programmable start and stop positions over the I²C interface
<ul style="list-style-type: none"> Great flexibility on angular excursion 	<ul style="list-style-type: none"> Maximum angle programmable from 18° up to 360°
<ul style="list-style-type: none"> High-resolution output signal 	<ul style="list-style-type: none"> 12-bit DAC output resolution
<ul style="list-style-type: none"> Selectable output 	<ul style="list-style-type: none"> Analog output ratiometric to VDD or PWM-encoded digital output

Benefits	Features
<ul style="list-style-type: none"> • Low-power consumption 	<ul style="list-style-type: none"> • Automatic entry into low-power mode
<ul style="list-style-type: none"> • Easy setup 	<ul style="list-style-type: none"> • Automatic magnet detection
<ul style="list-style-type: none"> • Small form factor 	<ul style="list-style-type: none"> • SOIC-8 package
<ul style="list-style-type: none"> • Robust environmental tolerance 	<ul style="list-style-type: none"> • Wide temperature range: -40°C to 125°C

Applications

The AS5600 is ideally suited for contactless potentiometers, contactless knobs, pedals, RC servos and other angular position measurement solutions.

Block Diagram

The functional blocks of this device are shown below:

Figure 2:
Functional Blocks of AS5600

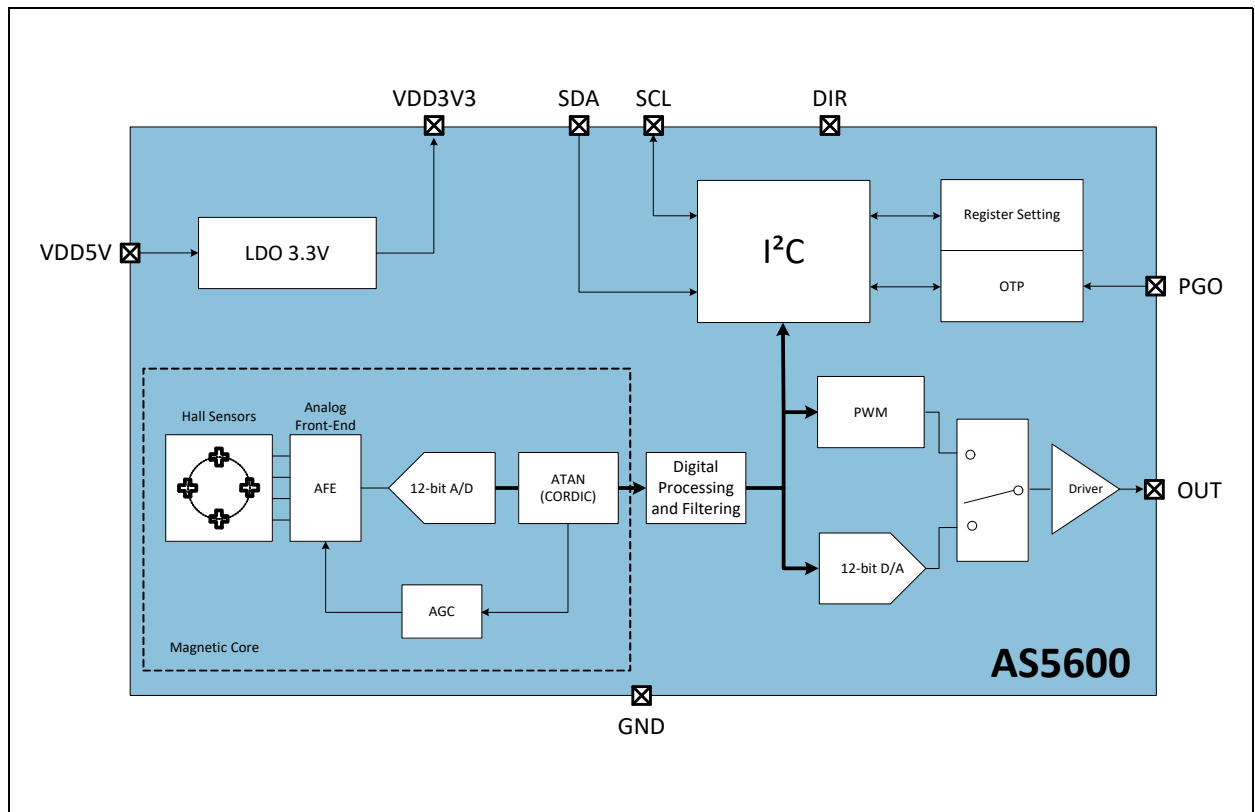

Pin Assignments

Figure 3:
SOIC-8 Pin-Out

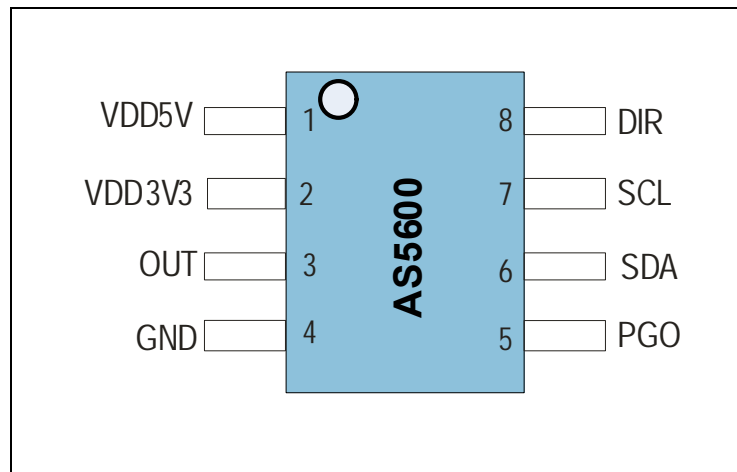

Figure 4:
Pin Description

Pin Number	Name	Type	Description
1	VDD5V	Supply	Positive voltage supply in 5V mode (requires 100nF decoupling capacitor)
2	VDD3V3	Supply	Positive voltage supply in 3.3V mode (requires an external 1- μ F decoupling capacitor in 5V mode)
3	OUT	Analog/digital output	Analog/PWM output
4	GND	Supply	Ground
5	PGO	Digital input	Program option (internal pull-up, connected to GND = Programming Option B)
6	SDA	Digital input/output	I ² C Data (consider external pull-up)
7	SCL	Digital input	I ² C Clock (consider external pull-up)
8	DIR	Digital input	Direction polarity (GND = values increase clockwise, VDD = values increase counterclockwise)

Absolute Maximum Ratings

Stresses beyond those listed under [Absolute Maximum Ratings](#) may cause permanent damage to the device. These are stress ratings only. Functional operation of the device at these or any other conditions beyond those indicated under [Operating Conditions](#) is not implied. Exposure to absolute maximum rating conditions for extended periods may affect device reliability.

Figure 5:
Absolute Maximum Ratings

Symbol	Parameter	Min	Max	Units	Comments
Electrical Parameters					
VDD5V	DC Supply Voltage at VDD5V pin	-0.3	6.1	V	
VDD3V3	DC Supply Voltage at VDD3V3 pin	-0.3	4.0	V	
VIO	DC Supply Voltage at all digital or analog pins	-0.3	VDD+0.3	V	
I _{SCR}	Input current (latch-up immunity)	-100	100	mA	JESD78
Continuous Power Dissipation (T_A = 70°C)					
P _T	Continuous power dissipation		50	mW	
Electrostatic Discharge					
ESD _{HBM}	Electrostatic discharge HBM	±1		kV	MIL 883 E method 3015.7
Temperature Ranges and Storage Conditions					
T _{STRG}	Storage temperature range	-55	125	°C	
T _{BODY}	Package body temperature		260	°C	ICP/JEDEC J-STD-020 The reflow peak soldering temperature (body temperature) is specified according to IPC/JEDEC J-STD-020 "Moisture/Reflow Sensitivity Classification for Non-hermetic Solid State Surface Mount Devices." The lead finish for Pb-free leaded packages is "Matte Tin" (100% Sn)
RH _{NC}	Relative humidity (non-condensing)	5	85	%	
MSL	Moisture sensitivity level	3			ICP/JEDEC J-STD-033

Electrical Characteristics

All limits are guaranteed. The parameters with minimum and maximum values are guaranteed with production tests or SQC (Statistical Quality Control) methods.

Operating Conditions

Figure 6:
System Electrical Characteristics and Temperature Range

Symbol	Parameter	Conditions	Min	Typ	Max	Units
VDD5V	Positive supply voltage in 5.0V mode	5.0V operation mode	4.5	5.0	5.5	V
		During OTP burn procedure ⁽²⁾				
VDD3V3	Positive supply voltage in 3.3V mode	3.3V operation mode	3.0	3.3	3.6	V
		During OTP burn procedure ⁽²⁾	3.25	3.3	3.35	V
IDD	Supply current in NOM ⁽¹⁾	PM = 00 Always on			6.5	mA
IDD_LPM1	Supply current in LPM1 ⁽¹⁾	PM = 01 Polling time = 5ms			3.4	mA
IDD_LPM2	Supply current in LPM2 ⁽¹⁾	PM = 10 Polling time = 20ms			1.8	mA
IDD_LPM3	Supply current in LPM3 ⁽¹⁾	PM = 11 Polling time = 100ms			1.5	mA
IDD_BURN	Supply current per bit for burn procedure	Initial peak, 1 μ s			100	mA
		Steady burning, <30 μ s			40	mA
T _A	Operating temperature		-40		125	°C
T _P	Programming temperature		20		30	°C

Note(s):

1. For typical magnetic field (60mT) excluding current delivered to the external load and tolerance on polling times.
2. For OTP burn procedure the supply line source resistance should not exceed 10 Ω .

Digital Inputs and Outputs

Figure 7:
Digital Input and Output Characteristics

Symbol	Parameter	Conditions	Min	Typ	Max	Units
V_IH	High-level input voltage		$0.7 \times VDD$			V
V_IL	Low-level input voltage				$0.3 \times VDD$	V
V_OH	High-level output voltage		$VDD - 0.5$			V
V_OL	Low-level output voltage				0.4	V
I_LKG	Leakage current				± 1	μA

Analog Output

Figure 8:
Analog Output Characteristics

Symbol	Parameter	Conditions	Min	Typ	Max	Units
INL_DAC	DAC integral-non-linearity electrical specification				± 5	LSB
DNL_DAC	DAC differential-non-linearity electrical specification				± 1	LSB
ROUT_FD	Output resistive load	0 to VDD output	100			$k\Omega$
ROUT_PD	Output resistive load	10% to 90% output	10			$k\Omega$
COUT	Output capacitive load				1	nF

PWM Output

Figure 9:
PWM Output Characteristics

Symbol	Parameter	Conditions	Min	Typ	Max	Units
PWMf1	PWM frequency ⁽¹⁾	PWMF = 00		115		Hz
PWMf2	PWM frequency ⁽¹⁾	PWMF = 01		230		Hz
PWMf3	PWM frequency ⁽¹⁾	PWMF = 10		460		Hz
PWMf4	PWM frequency ⁽¹⁾	PWMF = 11		920		Hz
PWM_DC	PWM duty cycle		2.9		97.1	%
PWM_SR	PWM slew rate	Cload = 1nF	0.5		2	V/μs
I _O	Output current for PWM output		±0.5			mA
C _L	Capacitive load for PWM output				1	nF

Note(s):

1. Frequency is given as typical values, tolerance is ±5%

Timing Characteristics

Figure 10:
Timing Conditions

Symbol	Parameter	Conditions	Min	Typ	Max	Units
T_DETWD	Watchdog detection time ⁽¹⁾	WD = 1		1		minute
T_PU	Power-up time				10	ms
F _S	Sampling rate				150	μs
T_SETTL1	Settling time	SF = 00			2.2	ms
T_SETTL2	Settling time	SF = 01			1.1	ms
T_SETTL3	Settling time	SF = 10			0.55	ms
T_SETTL4	Settling time	SF = 11			0.286	ms

Note(s):

1. Given as typical values, tolerance is ±5%

Magnetic Characteristics

Figure 11:
Magnetic Characteristics

Symbol	Parameter	Conditions	Min	Max	Units
Bz	Orthogonal magnetic field strength, regular output noise ON_SLOW and ON_FAST	Required orthogonal component of the magnetic field strength measured at the die's surface along a circle of 1mm	30	90	mT
Bz_ERROR	Minimum required orthogonal magnetic field strength, Magnet detection level			8	mT

System Characteristics

Figure 12:
System Specifications

Symbol	Parameter	Conditions	Min	Typ	Max	Units
RES	Resolution			12		bit
INL_BL	System INL	Deviation from best line fit; 360° maximum angle, no magnet displacement, no zero-programming performed (PWM, I ² C)			±1	degree
ON_SLOW	RMS output noise (1 sigma)	Orthogonal component for the magnetic field within the specified range (Bz), after 2.2 ms; SF = 00			0.015	degree
ON_FAST	RMS output noise (1 sigma)	Orthogonal component for the magnetic field within the specified range (Bz), after 286 μs, SF=11			0.043	degree

Detailed Description

The AS5600 is a Hall-based rotary magnetic position sensor using planar sensors that convert the magnetic field component perpendicular to the surface of the chip into a voltage.

The signals coming from the Hall sensors are first amplified and filtered before being converted by the analog-to-digital converter (ADC). The output of the ADC is processed by the hardwired CORDIC block (Coordinate Rotation Digital Computer) to compute the angle and magnitude of the magnetic field vector. The intensity of the magnetic field is used by the automatic gain control (AGC) to adjust the amplification level to compensate for temperature and magnetic field variations.

The angle value provided by the CORDIC algorithm is used by the output stage. The user can choose between an analog output and a PWM-encoded digital output. The former provides an output voltage which represents the angle as a ratiometric linear absolute value. The latter provides a digital output which represents the angle as the pulse width.

The AS5600 is programmed through an industry-standard I²C interface to write an on-chip non-volatile memory. This interface can be used to program a zero angle (start position) and a maximum angle (stop position) which maps the full resolution of the output to a subset of the entire 0 to 360 degree range.

IC Power Management

The AS5600 can be powered from a 5.0V supply using the on-chip LDO regulator, or it can be powered directly from a 3.3V supply. The internal LDO is not intended to power other external ICs and needs a 1 μ F capacitor to ground, as shown in [Figure 13](#).

In 3.3V operation, the VDD5V and VDD3V3 pins must be tied together. VDD is the voltage level present at the VDD5V pin.

Figure 13:
5.0V and 3.3V Power Supply Options

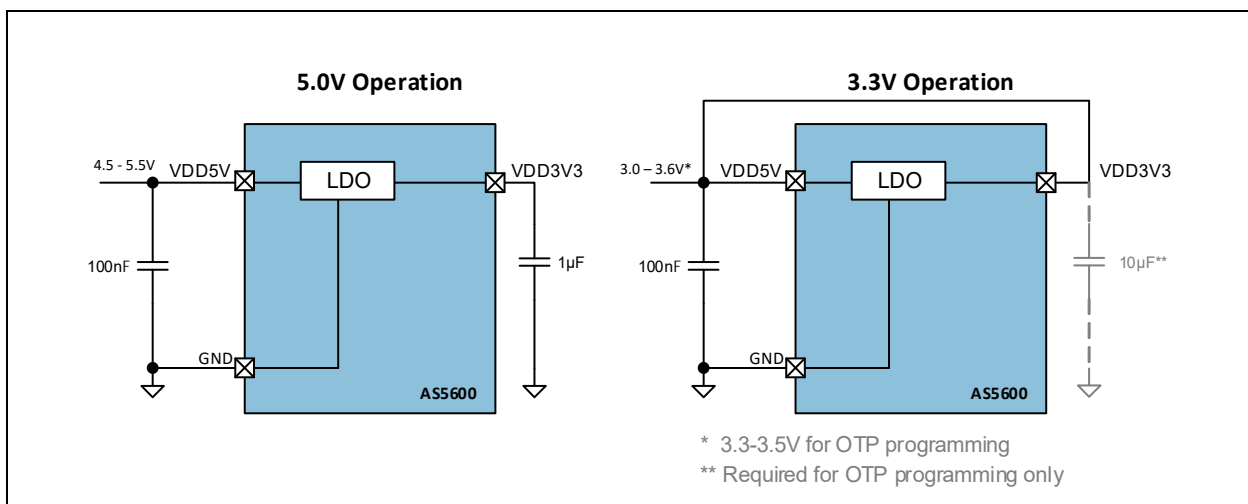

I²C Interface

The AS5600 supports the 2-wire Fast-mode Plus I²C-slave protocol in device mode, in compliance with the NXP Semiconductors (formerly Philips Semiconductors) specification UM10204. A device that sends data onto the bus is a transmitter and a device receiving data is a receiver. The device that controls the message is called a master. The devices that are controlled by the master are called slaves. A master device generates the serial clock (SCL), controls the bus access, and generates the START and STOP conditions that control the bus. The AS5600 always operates as a slave on the I²C bus. Connections to the bus are made through the open-drain I/O lines SDA and the input SCL. Clock stretching is not included.

The host MCU (master) initiates data transfers. The 7-bit slave address of the AS5600 is 0x36 (0110110 in binary).

Supported Modes

- Random/Sequential read
- Byte/Page write
- Automatic increment (ANGLE register)
- Standard-mode
- Fast-mode
- Fast-mode plus

The SDA signal is the bidirectional data line. The SCL signal is the clock generated by the I²C bus master to synchronize sampling data from SDA. The maximum SCL frequency is 1 MHz. Data is sampled on the rising edge of SCL.

I²C Interface Operation

Figure 14:
I²C Timing Diagram

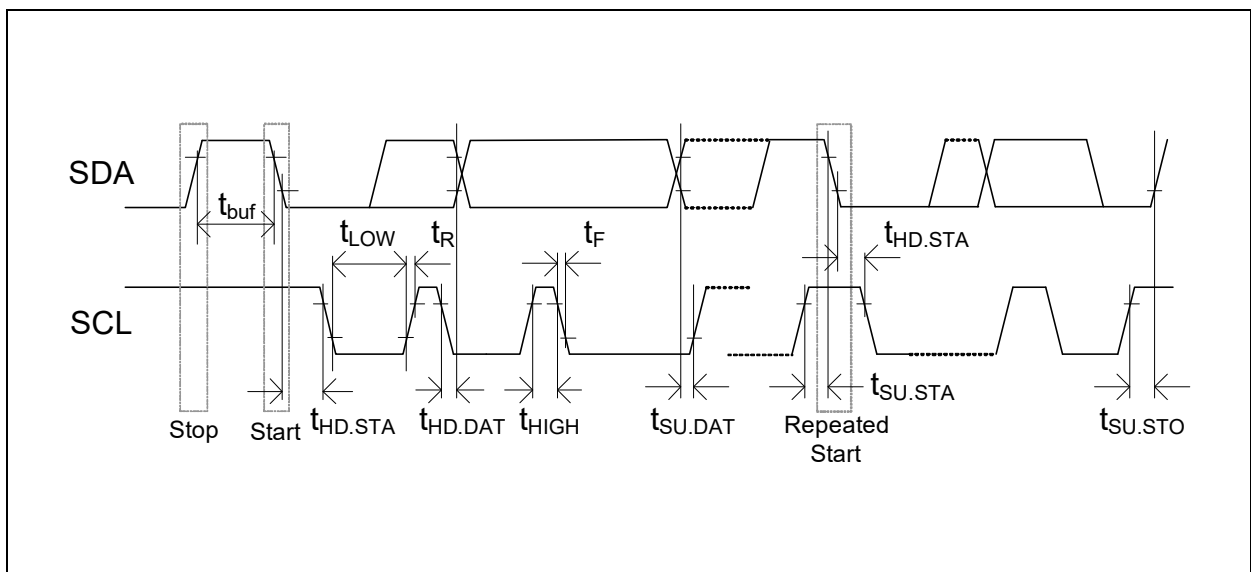

I²C Electrical Specification

Figure 15:
I²C Electrical Specifications

Symbol	Parameter	Conditions	Min	Typ	Max	Unit
V _{IL}	Logic low input voltage		-0.3		0.3 x VDD	V
V _{IH}	Logic high input voltage		0.7 x VDD		VDD + 0.3	V
V _{HYS}	Hysteresis of Schmitt trigger inputs	VDD > 2.5V	0.05 x VDD			V
V _{OL}	Logic low output voltage (open-drain or open-collector) at 3 mA sink current	VDD > 2.5V			0.4	V
I _{OL}	Logic low output current	V _{OL} = 0.4V	20			mA
t _{OF}	Output fall time from V _{IHmax} to V _{ILmax}		10		120 ⁽¹⁾	ns
t _{SP}	Pulse width of spikes that must be suppressed by the input filter				50 ⁽²⁾	ns
I _I	Input current at each I/O Pin	Input Voltage between 0.1 x VDD and 0.9 x VDD	-10		+10 ⁽³⁾	μA
C _B	Total capacitive load for each bus line				550	pF
C _{I/O}	I/O capacitance (SDA, SCL) ⁽⁴⁾				10	pF

Note(s):

1. In Fast-mode Plus, fall time is specified the same for both output stage and bus timing. If series resistors are used this has to be considered for bus timing.
2. Input filters on the SDA and SCL inputs suppress noise spikes of less than 50 ns.
3. I/O pins of Fast-mode and Fast-mode Plus devices must not load or drive the SDA and SCL lines if VDD is switched OFF.
4. Special-purpose devices such as multiplexers and switches may exceed this capacitance because they connect multiple paths together.

I²C Timing

Figure 16:
I²C Timing

Symbol	Parameter	Min	Max	Unit
f_{SCLK}	SCL clock frequency		1.0	MHz
t_{BUF}	Bus free time (time between the STOP and START conditions)	0.5		μs
$t_{\text{HD;STA}}$	Hold time; (Repeated) START condition ⁽¹⁾	0.26		μs
t_{LOW}	Low phase of SCL clock	0.5		μs
t_{HIGH}	High phase of SCL clock	0.26		μs
$t_{\text{SU;STA}}$	Setup time for a Repeated START condition	0.26		μs
$t_{\text{HD;DAT}}$	Data hold time ⁽²⁾		0.45	μs
$t_{\text{SU;DAT}}$	Data setup time ⁽³⁾	50		ns
t_{R}	Rise time of SDA and SCL signals		120	ns
t_{F}	Fall time of SDA and SCL signals	10	120 ⁽⁴⁾	ns
$t_{\text{SU;STO}}$	Setup time for STOP condition	0.26		μs

Note(s):

1. After this time, the first clock is generated.
2. A device must internally provide a minimum hold time of 120 ns (Fast-mode Plus) for the SDA signal (referred to the V_{IHmin} of SCL) to bridge the undefined region of the falling edge of SCL.
3. A Fast-mode device can be used in a standard-mode system, but the requirement $t_{\text{SU;DAT}} = 250$ ns must be met. This is automatically if the device does not stretch the low phase of SCL. If such a device does stretch the low phase of SCL, it must drive the next data bit on SDA ($t_{\text{Rmax}} + t_{\text{SU;DAT}} = 1000 + 250 = 1250$ ns) before SCL is released.
4. In Fast-mode Plus, fall time is specified the same for both output stage and bus timing. If series resistors are used, this has to be considered for bus timing.

I²C Modes

Invalid Addresses

There are two addresses used to access an AS5600 register. The first is the slave address used to select the AS5600. All I²C bus transactions include a slave address. The slave address of the AS5600 is 0x36 (0110110 in binary). The second address is a word address sent in the first byte transferred in a write transaction. The word address selects a register on the AS5600. The word address is loaded into the address pointer on the AS5600. During subsequent read transactions and subsequent bytes in the write transaction, the address pointer provides the address of the selected register. The address pointer is incremented after each byte is transferred, except for certain read transactions to special registers.

If the user sets the address pointer to an invalid word address, the address byte is not acknowledged (the A bit is high). Nevertheless, a read or write cycle is possible. The address pointer is increased after each byte.

Reading

When reading from an invalid address, the AS5600 returns all zeros in the data bytes. The address pointer is incremented after each byte. Sequential reads over the whole address range are possible including address overflow.

Automatic Increment of the Address Pointer for ANGLE, RAW ANGLE and MAGNITUDE Registers

These are special registers which suppress the automatic increment of the address pointer on reads, so a re-read of these registers requires no I²C write command to reload the address pointer. This special treatment of the pointer is effective only if the address pointer is set to the high byte of the register.

Writing

A write to an invalid address is not acknowledged by the AS5600, although the address pointer is incremented. When the address pointer points to a valid address again, a successful write accessed is acknowledged. Page write over the whole address range is possible including address overflow.

Supported Bus Protocol

Data transfer may be initiated only when the bus is not busy. During data transfer, the data line must remain stable whenever SCL is high. Changes in the data line while SCL is high are interpreted as START or STOP conditions.

Accordingly, the following bus conditions have been defined:

Bus Not Busy

Both SDA and SCL remain high.

Start Data Transfer

A change in the state of SDA from high to low while SCL is high defines the START condition.

Stop Data Transfer

A change in the state of SDA from low to high while SCL is high defines the STOP condition.

Data Valid

The state of the data line represents valid data when, after a START condition, SDA is stable for the duration of the high phase of SCL. The data on SDA must be changed during the low phase of SCL. There is one clock period per bit of data.

Each I²C bus transaction is initiated with a START condition and terminated with a STOP condition. The number of data bytes transferred between START and STOP conditions is not limited, and is determined by the I²C bus master. The information is transferred byte-wise and each receiver acknowledges with a ninth bit.

Acknowledge

Each I²C slave device, when addressed, is obliged to generate an acknowledge after the reception of each byte. The I²C bus master device must generate an extra clock period for this acknowledge bit.

A slave that acknowledges must pull down SDA during the acknowledge clock period in such a way that SDA is stable low during the high phase of the acknowledge clock period. Of course, setup and hold times must be taken into account. A master must signal an end of a read transaction by not generating an acknowledge bit on the last byte that has been clocked out of the slave. In this case, the slave must leave SDA high to enable the master to generate the STOP condition.

Figure 17:
Data Read

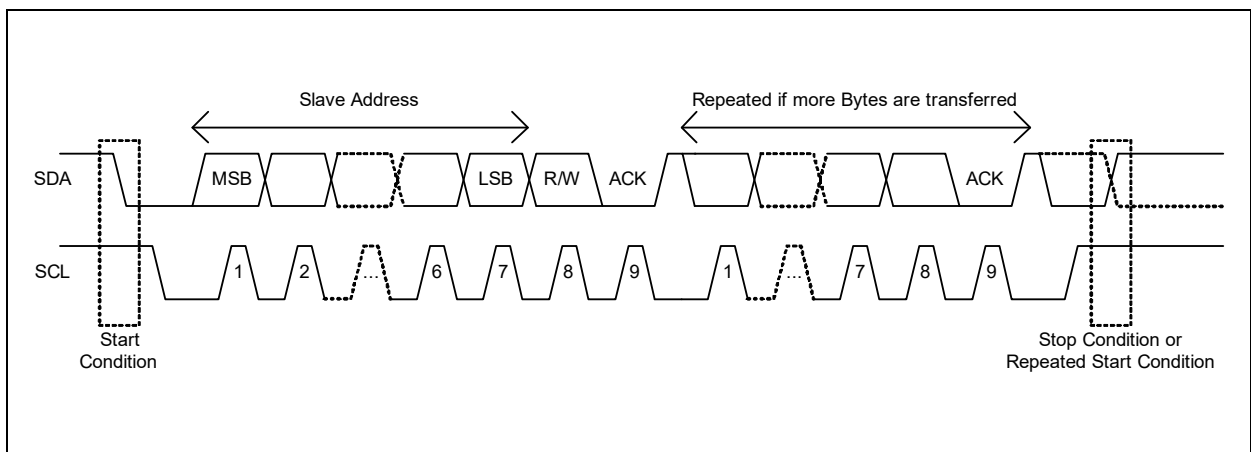

Depending on the state of the R/W bit, two types of data transfer are possible:

Data Transfer from a Master Transmitter to a Slave Receiver

The first byte transmitted by the master is the slave address, followed by R/W = 0. Next follows a number of data bytes. The slave returns an acknowledge bit after each received byte. If the slave does not understand the command or data it sends a not acknowledge (NACK). Data is transferred with the most significant bit (MSB) first.

Data Transfer from a Slave Transmitter to a Master Receiver

The master transmits the first byte (the slave address). The slave then returns an acknowledge bit, followed by the slave transmitting a number of data bytes. The master returns an acknowledge bit after all received bytes other than the last byte. At the end of the last received byte, a NACK is returned. The master generates all of the SCL clock periods and the START and STOP conditions. A transfer is ended with a STOP condition or with a repeated START condition. Because a repeated START condition is also the beginning of the next serial transfer, the bus is not released. Data is transferred with the most significant bit (MSB) first.

AS5600 Slave Modes

Slave Receiver Mode (Write Mode)

Serial data and clock are received through SDA and SCL. Each byte is followed by an acknowledge bit or by a not acknowledge depending on whether the address-pointer selects a valid address. START and STOP conditions are recognized as the beginning and end of a bus transaction. The slave address byte is the first byte received after the START condition. The 7-bit AS5600 address is 0x36 (0110110 in binary).

The 7-bit slave address is followed by the direction bit (R/W), which, for a write, is 0 (low). After receiving and decoding the slave address byte the slave device drives an acknowledge on SDA. After the AS5600 acknowledges the slave address and write bit, the master transmits a register address (word address) to the AS5600. This is loaded into the address pointer on the AS5600. If the address is a valid readable address, the AS5600 answers by sending an acknowledge (A bit low). If the address pointer selects an invalid address, a not acknowledge is sent (A bit high). The master may then transmit zero or more bytes of data. If the address pointer selects an invalid address, the received data are not stored. The address pointer will increment after each byte transferred whether or not the address is valid. If the address-pointer reaches a valid position again, the AS5600 answers with an acknowledge and stores the data. The master generates a STOP condition to terminate the write transaction.

Figure 18:
Data Write (Slave Receiver Mode)

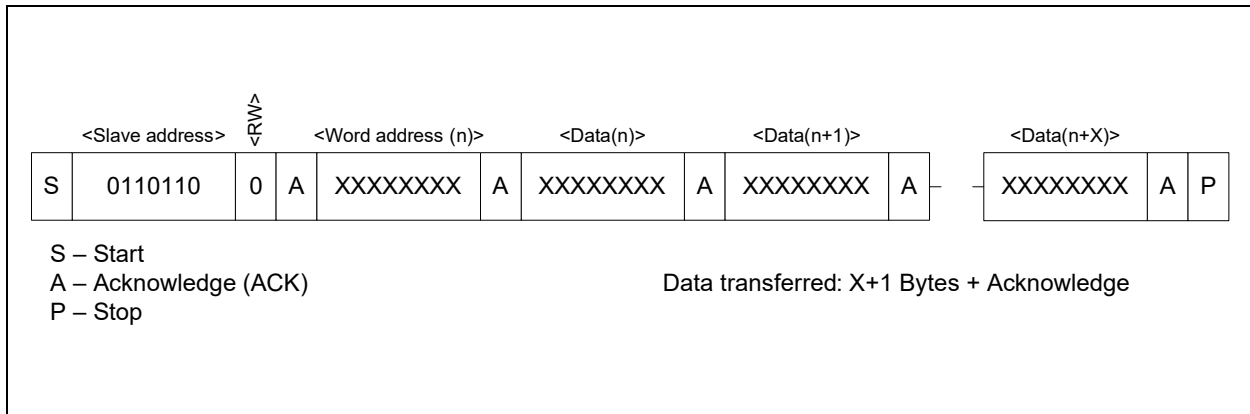

Slave Transmitter Mode (Read Mode)

The first byte is received and handled as in the slave receiver mode. However, in this mode, the direction bit indicates that the AS5600 will drive data on SDA. START and STOP conditions are recognized as the beginning and end of a bus transaction. The slave address byte is the first byte received after the master generates a START condition. The slave address byte contains the 7-bit AS5600 address. The 7-bit slave address is followed by the direction bit (R/W), which, for a read, is 1 (high). After receiving and decoding the slave address byte, the slave device drives an acknowledge on the SDA line. The AS5600 then begins to transmit data starting with the register address pointed to by the address pointer. If the address pointer is not written before the initiation of a read transaction, the first address that is read is the last one stored in the address pointer. The AS5600 must receive a not acknowledge (NACK) to end a read transaction.

Figure 19:
Data Read (Slave Transmitter Mode)

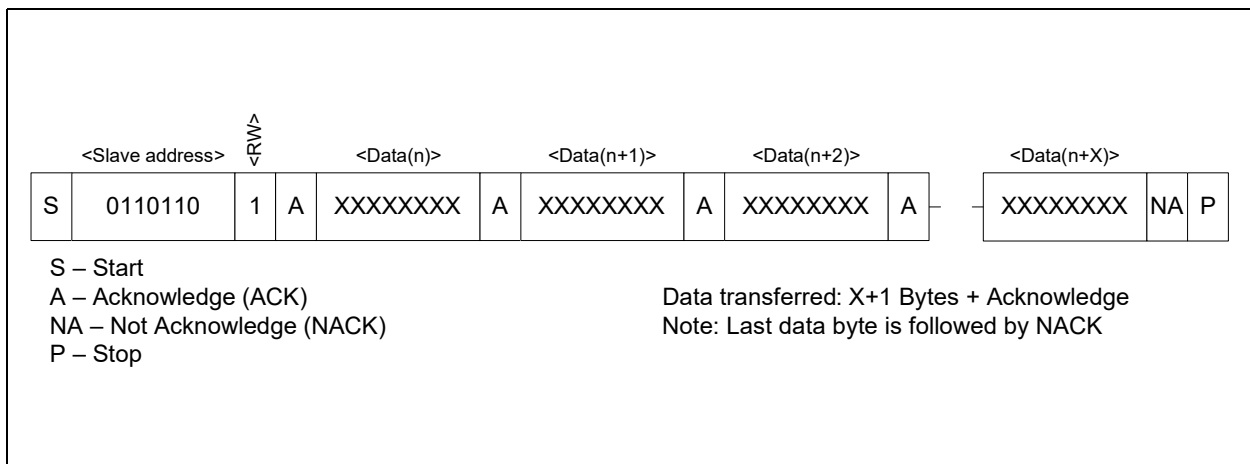
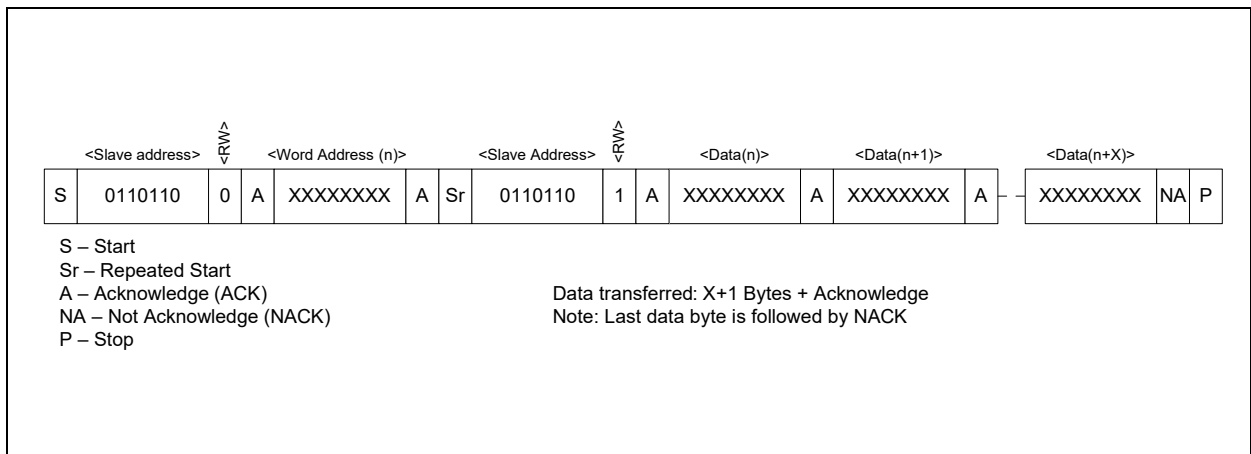

Figure 20:
Data Read with Address Pointer Reload (Slave Transmitter Mode)



SDA and SCL Input Filters

Input filters for SDA and SCL inputs are included to suppress noise spikes of less than 50 ns.

Register Description

The following registers are accessible over the serial I²C interface. The 7-bit device address of the slave is 0x36 (0110110 in binary). To permanently program a configuration, a non-volatile memory (OTP) is provided.

Figure 21:
Register Map

Address	Name	R/W	Bit 7	Bit 6	Bit 5	Bit 4	Bit 3	Bit 2	Bit 1	Bit 0
Configuration Registers ^{(1), (2)}										
0x00	ZMCO	R								ZMCO(1:0)
0x01	ZPOS	R/W/P						ZPOS(11:8)		
0x02			ZPOS(7:0)							
0x03	MPOS	R/W/P						MPOS(11:8)		
0x04			MPOS(7:0)							
0x05	MANG	R/W/P						MANG(11:8)		
0x06			MANG(7:0)							
0x07	CONF	R/W/P			WD	FTH(2:0)			SF(1:0)	
0x08			PWMF(1:0)	OUTS(1:0)	HYST(1:0)	PM(1:0)				
Output Registers										
0x0C	RAW ANGLE	R						RAW ANGLE(11:8)		
0x0D		R	RAW ANGLE(7:0)							
0x0E	ANGLE	R						ANGLE(11:8)		
0x0F		R	ANGLE(7:0)							
Status Registers										
0x0B	STATUS	R			MD	ML	MH			
0x1A	AGC	R	AGC(7:0)							
0x1B	MAGNITUDE	R						MAGNITUDE (11:8)		
0x1C		R	MAGNITUDE(7:0)							
Burn Commands										
0xFF	BURN	W	Burn_Angle = 0x80; Burn_Setting = 0x40							

Note(s):

- To change a configuration, read out the register, modify only the desired bits and write the new configuration. Blank fields may contain factory settings.
- During power-up, configuration registers are reset to the permanently programmed value. Not programmed bits are zero.

ZPOS/MPOS/MANG Registers

These registers are used to configure the start position (ZPOS) and a stop position (MPOS) or maximum angle (MANG) for a narrower angular range. The angular range must be greater than 18 degrees. In case of narrowed angular range, the resolution is not scaled to narrowed range (e.g. 0° to 360°(full-turn) → 4096dec; 0° to 180° → 2048dec). To configure the angular range, see [Angle Programming](#).

CONF Register

The CONF register supports customizing the AS5600. [Figure 22](#) shows the mapping of the CONF register.

Figure 22:
CONF Register

Name	Bit Position	Description
PM(1:0)	1:0	Power Mode 00 = NOM, 01 = LPM1, 10 = LPM2, 11 = LPM3
HYST(1:0)	3:2	Hysteresis 00 = OFF, 01 = 1 LSB, 10 = 2 LSBs, 11 = 3 LSBs
OUTS(1:0)	5:4	Output Stage 00 = analog (full range from 0% to 100% between GND and VDD, 01 = analog (reduced range from 10% to 90% between GND and VDD, 10 = digital PWM
PWMF (1:0)	7:6	PWM Frequency 00 = 115 Hz; 01 = 230 Hz; 10 = 460 Hz; 11 = 920 Hz
SF(1:0)	9:8	Slow Filter 00 = 16x ⁽¹⁾ ; 01 = 8x; 10 = 4x; 11 = 2x
FTH(2:0)	12:10	Fast Filter Threshold 000 = slow filter only, 001 = 6 LSBs, 010 = 7 LSBs, 011 = 9 LSBs, 100 = 18 LSBs, 101 = 21 LSBs, 110 = 24 LSBs, 111 = 10 LSBs
WD	13	Watchdog 0 = OFF, 1 = ON

Note(s):

1. Forced in Low Power Mode (LPM)

ANGLE/RAW ANGLE Register

The RAW ANGLE register contains the unscaled and unmodified angle. The scaled output value is available in the ANGLE register.

Note(s): The ANGLE register has a 10-LSB hysteresis at the limit of the 360 degree range to avoid discontinuity points or toggling of the output within one rotation.

STATUS Register

The STATUS register provides bits that indicate the current state of the AS5600.

Figure 23:
STATUS Register

Name	State When Bit Is High
MH	AGC minimum gain overflow, magnet too strong
ML	AGC maximum gain overflow, magnet too weak
MD	Magnet was detected

AGC Register

The AS5600 uses Automatic Gain Control in a closed loop to compensate for variations of the magnetic field strength due to changes of temperature, airgap between IC and magnet, and magnet degradation. The AGC register indicates the gain. For the most robust performance, the gain value should be in the center of its range. The airgap of the physical system can be adjusted to achieve this value.

In 5V operation, the AGC range is 0-255 counts. The AGC range is reduced to 0-128 counts in 3.3V mode.

MAGNITUDE Register

The MAGNITUDE register indicates the magnitude value of the internal CORDIC.

Non-Volatile Memory (OTP)

The non-volatile memory is used to permanently program the configuration. To program the non-volatile memory, the I²C interface is used ([Option A](#), [Option C](#)). Alternatively, start and stop positions can be programmed through the output pin ([Option B](#)). The programming can be either performed in the 5V supply mode or in the 3.3V operation mode but using a minimum supply voltage of 3.3V and a 10 µF capacitor at the VDD3V3 pin to ground. This 10 µF capacitor is needed only during the programming of the device. Two different commands are used to permanently program the device:

Burn_Angle Command (ZPOS, MPOS)

The host microcontroller can perform a permanent programming of ZPOS and MPOS with a BURN_ANGLE command. To perform a BURN_ANGLE command, write the value 0x80 into register 0xFF. The BURN_ANGLE command can be executed up to 3 times. ZMCO shows how many times ZPOS and MPOS have been permanently written.

This command may only be executed if the presence of the magnet is detected (MD = 1).

Burn_Setting Command (MANG, CONFIG)

The host microcontroller can perform a permanent writing of MANG and CONFIG with a BURN_SETTING command. To perform a BURN_SETTING command, write the value 0x40 into register 0xFF.

MANG can be written only if ZPOS and MPOS have never been permanently written (ZMCO = 00). The BURN_SETTING command can be performed only one time.

Angle Programming

For applications which do not use the full 0 to 360 degree angular range, the output resolution can be enhanced by programming the range which is actually used. In this case, the full resolution of the output is automatically scaled to the programmed angular range. The angular range must be greater than 18 degrees.

The range is specified by programming a start position (ZPOS) and either a stop position (MPOS) or the size of the angular range (MANG).

The BURN_ANGLE command can be executed up to 3 times.

There are three recommended methods for programming the angular range:

- **Option A:** Angle Programming Through the I²C Interface
- **Option B:** Angle Programming Through the OUT Pin
- **Option C:** Programming a Maximum Angular Range Through the I²C Interface

Figure 24:
Option A: Angle Programming Through the I²C Interface

Use the correct hardware configuration shown in Figure 37 and Figure 38 .	
Step 1	Power up the AS5600.
Step 2	Turn the magnet to the start position.
Step 3	Read the RAW ANGLE register. Write the RAW ANGLE value into the ZPOS register. Wait at least 1 ms.
Step 4	Rotate the magnet in the direction defined by the level on the DIR pin (GND for clockwise, VDD for counterclockwise) to the stop position. The amount of rotation must be greater than 18 degrees.
Step 5	Read the RAW ANGLE register. Write the RAW ANGLE value into the MPOS register. Wait at least 1 ms.
Proceed with Step 6 to permanently program the configuration.	
Step 6	Perform a BURN_ANGLE command to permanently program the device. Wait at least 1 ms.
Step 7	Verify the BURN_ANGLE command: Write the commands 0x01, 0x11 and 0x10 sequentially into the register 0xFF to load the actual OTP content. Read the ZPOS and MPOS registers to verify that the BURN_ANGLE command was successful.
Step 8	Read and verify the ZPOS and MPOS registers again after a new power-up cycle.

Note(s):

1. After each register command, the new setting is effective at the output at least 1 ms later.
2. It is highly recommended to perform a functional test after this procedure.

Figure 25:
Option B: Angle Programming Through the OUT Pin

Use the correct hardware configuration shown in Figure 37 and Figure 38 . The PGO pin is connected to GND and the OUT pin is pulled high by an internal resistor until the programming procedure is finished.	
Step 1	Power up the AS5600.
Step 2	Position the magnet in the start position.
Step 3	Pull the OUT pin to GND for at least 100 ms, then allow the pin to float.
Step 4	Rotate the magnet in the same direction defined by the level on the DIR pin (GND for clockwise, VDD for counterclockwise) to the stop position. The amount of rotation must be greater than 18 degrees.
Step 5	Pull the OUT pin to GND for at least 100 ms, then allow the pin to float.
Step 6	Check if the OUT pin is permanently driven to GND. This indicates an error occurred during programming. If the voltage driven on the OUT pin corresponds to the magnet position, the procedure was performed successfully.

Note(s):

1. After step 5 the new setting is effective at the output.
2. If step 3 is not followed by step 5 no permanent write will be performed.
3. It is highly recommended to perform a functional test after the procedure.
4. This procedure can be executed only one time; the zero position and maximum angle can be reprogrammed only through the I²C ([Option A](#)).
5. This procedure can be executed only if the presence of the magnet is detected (MD = 1).

Figure 26:
Option C: Programming a Maximum Angular Range Through the I²C Interface

Use the correct hardware configuration shown in Figure 37 and Figure 38 .	
Step 1	Power up the AS5600.
Step 2	Use the I ² C interface to write the maximum angular range into the MANG register. For example, if the maximum angular range is 90 degrees, write the MANG register with 0x400. Configure additional configuration settings by writing the CONFIG register. Wait at least 1 ms.
Proceed with Step 3 to permanently program the configuration.	
Step 3	Perform a BURN_SETTINGS command to permanently program the device. Wait at least 1 ms.
Step 4	Verify the BURN_SETTINGS command: Write the commands 0x01, 0x11 and 0x10 sequentially into the register 0xFF to load the actual OTP content. Read and verify the MANG and CONF registers to verify that the BURN_SETTINGS command was successful.
Proceed with Step 5 to permanently program a zero position. If the OUT pin is used for this option, the PGO pin must be connected to GND.	
Step 5	Position the magnet in the start position (zero angle).
Step 6	Pull the OUT pin to GND for at least 100 ms, then allow the pin to float. Alternatively, program the zero position through the I ² C interface (Option A). Wait at least 1 ms.
Step 7	Verify the permanent programming by I ² C (Option A) or check if OUT is permanently driven to GND (Option B).
Step 8	Read and verify the permanently programmed registers again after a new power-up cycle.

Note(s):

1. After each register command, the new configuration is effective at the output at least 1 ms later.
2. It is recommended to perform a functional test after this procedure.

Output Stage

The OUTS bits in the CONF register are used to choose between an analog ratiometric output (default) and a digital PWM output. If PWM is selected, the DAC is powered down.

Without regard to which output is enabled, an external unit can read the angle from the ANGLE register through I²C interface at any time.

Analog Output Mode

By default, the AS5600 output stage is configured as analog ratiometric output. The Digital to Analog Converter (DAC) has 12-bit resolution. In default mode, the lower reference voltage for the DAC is GND, while the upper reference voltage is VDD. The output voltage on the OUT pin is ratiometric between GND and VDD.

The maximum angular range can be programmed from 18 degrees to 360 degrees. The default range is 360 degrees.

As shown below, if the range is 360 degrees, to avoid discontinuity points exactly at the limit of the range, a 10-LSB hysteresis is applied. This hysteresis suppresses toggling the OUT pin when the magnet is close to zero or 360 degrees.

Figure 27:
Output Characteristic Over a 360° Full-Turn Revolution

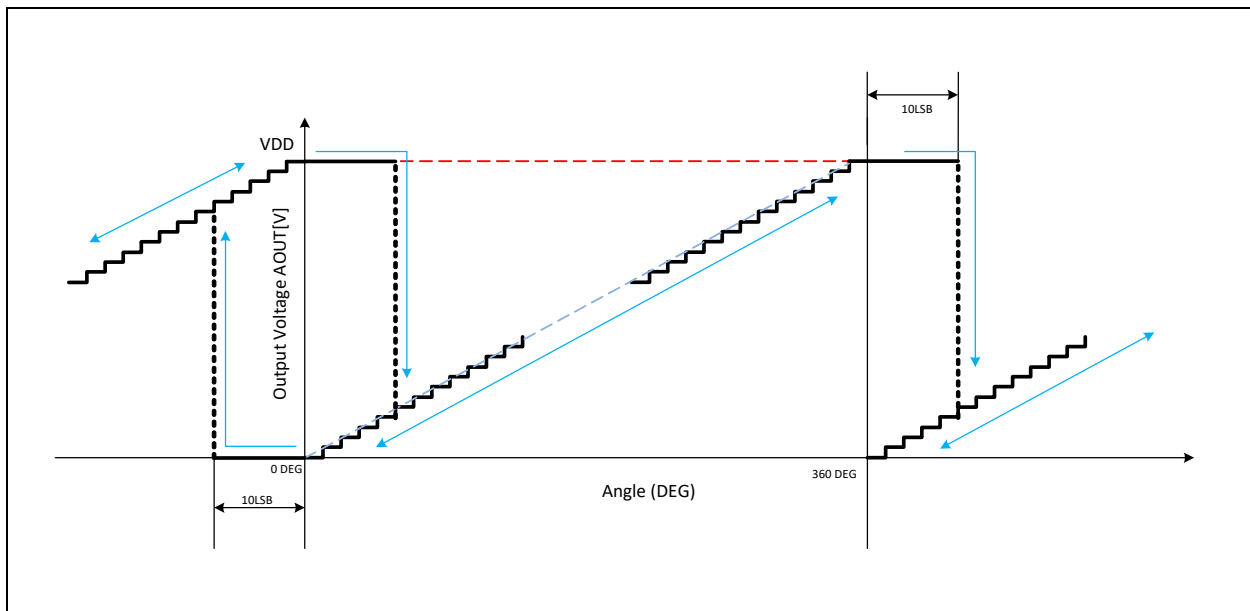

The AS5600 supports programming both a zero angle as well as the maximum angular range. As shown in [Figure 28](#), reducing the maximum angular range pushes the non-discontinuity points to the edges, away from the 0 and θ_{\max} (where θ_{\max} is the maximum angle) by λ , where $\lambda = (360 - \theta_{\max})/2$.

Figure 28:
Output Characteristic Over a Range Smaller Than 360°

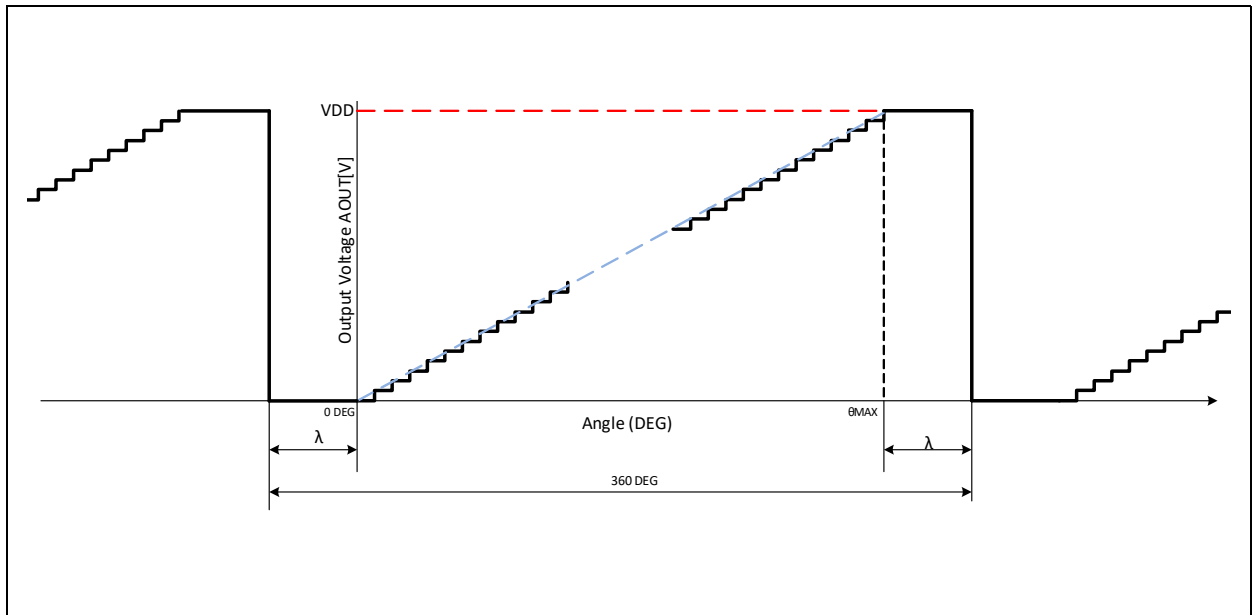

If the maximum angular range is smaller than 360 degrees, the DAC resolution is automatically reduced. If θ_{max} is the maximum angle, the number of steps N of the output signal OUT is:

$$N = (\theta_{max}/360) \times 4096$$

The AS5600 also allows selecting the output dynamic characteristics of the OUT signal with the OUTS bits in the CONF register. By default (OUTS = 00), the output can cover the full voltage range (0V to VDD), but a reduced range from 10% to 90% between GND and VDD may be programmed (OUTS = 01).

Figure 29:
Output Characteristics with Reduced Output Range (10%-90%)

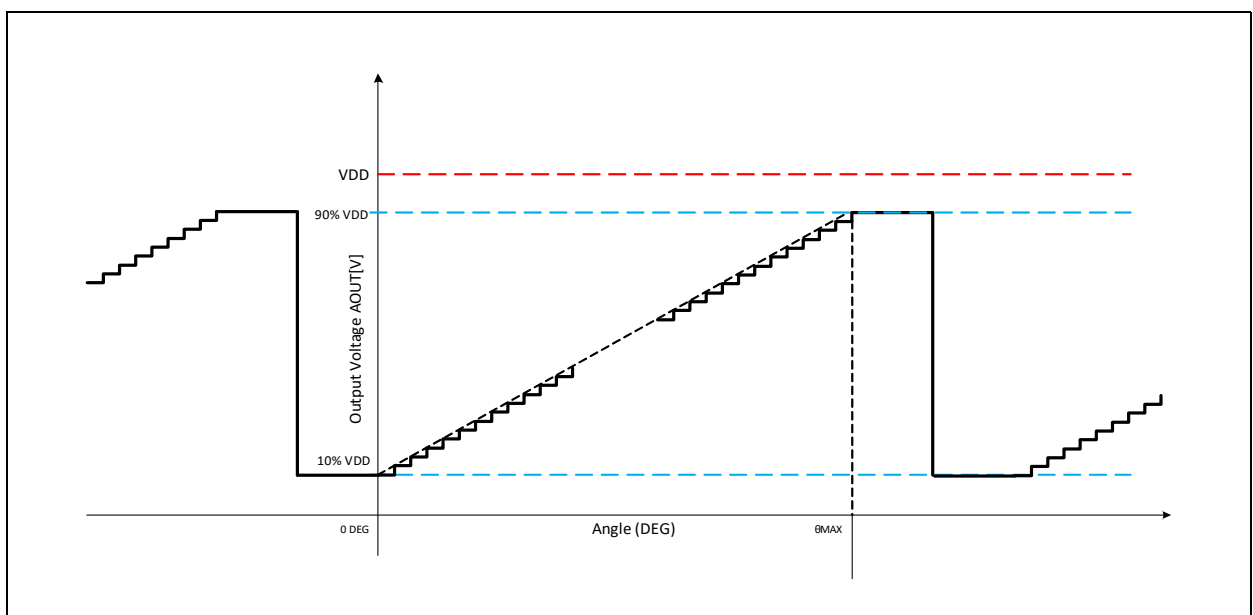

PWM Output Mode

The AS5600 output stage can be programmed in the OUTS bits of the CONF register for a PWM-encoded digital output (OUTS = 10). In this mode, the OUT pin provides a digital PWM signal. The duty cycle of each pulse is proportional to the absolute angle of the rotating magnet.

The PWM signal consists of a frame of 4351 PWM clock periods as shown in Figure 30. This PWM frame is composed of the following sections:

- 128 PWM clock periods high
- 4095 PWM clock periods data
- 128 PWM clock periods low

The angle is represented in the data part of the frame, and one PWM clock period represents one 4096th of the full angular range. The PWM frequency is programmed with the PWMF bits in the CONF register.

Figure 30:
Output Characteristics in Pulse Width Modulation Mode

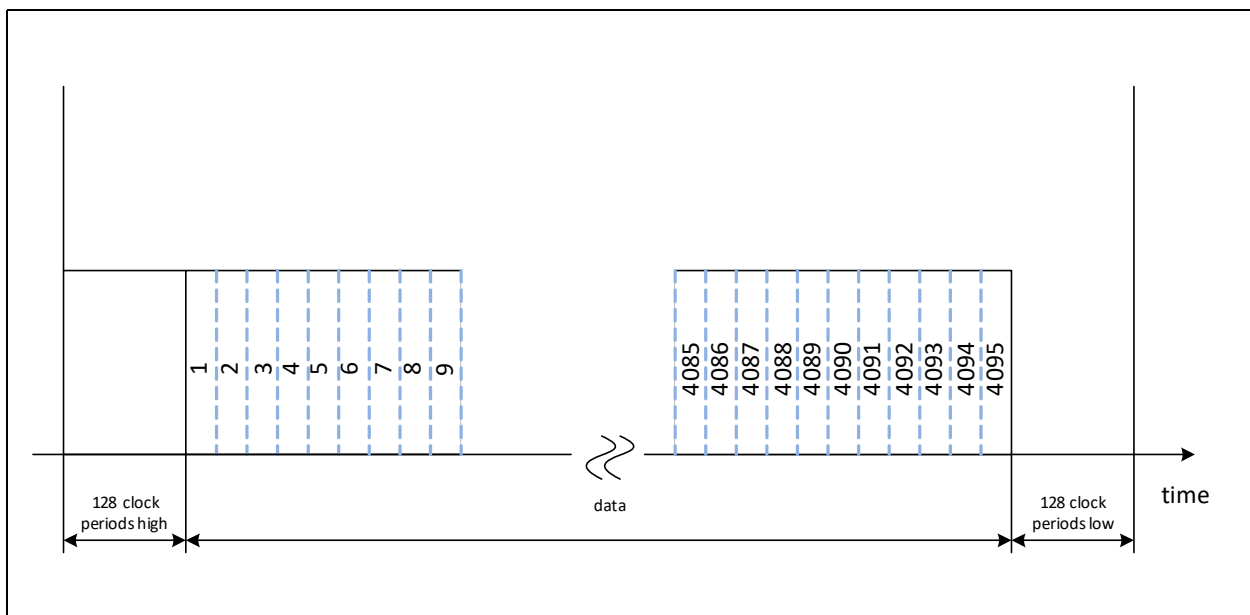

An angle of zero degrees is represented by 128 clock periods high and 4223 clock periods low, while a maximum angle consists of 4223 clock periods high and 128 clock periods low.

Step Response and Filter Settings

The AS5600 has a digital post-processing programmable filter which can be set in fast or slow modes. The fast filter mode can be enabled by setting a fast filter threshold in the FTH bits of the CONF register.

If the fast filter is OFF, the step output response is controlled by the slow linear filter. The step response of the slow filter is programmable with the SF bits in the CONF register. Figure 32 shows the tradeoff between delay and noise for the different SF bit settings.

Figure 31:
Step Response Delay vs. Noise Band

SF	Step Response Delay (ms)	Max. RMS Output Noise (1 Sigma) (Degree)
00	2.2	0.015
01	1.1	0.021
10	0.55	0.030
11	0.286	0.043

Figure 32:
Step Response (fast filter OFF)

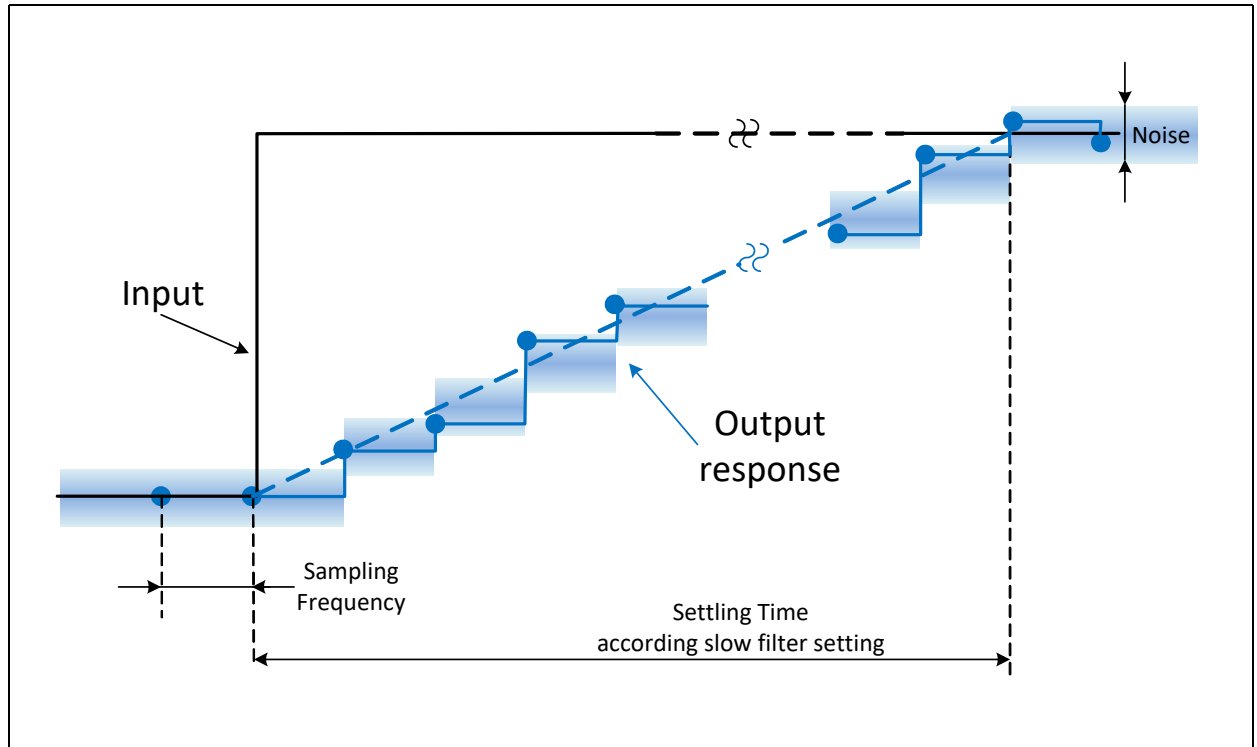

For a fast step response and low noise after settling, the fast filter can be enabled. The fast filter works only if the input variation is greater than the fast filter threshold, otherwise the output response is determined only by the slow filter. The fast filter threshold is programmed with the **FTH bits** in the **CONF Register**. As shown in **Figure 34**, the step response stays within an error band after two full sampling periods to settle to the final value determined by the slow filter.

Figure 33:
Fast Filter Threshold

FTH	Fast Filter Threshold (LSB)	
	Slow-to-fast filter	Fast-to-slow filter
000	Slow filter only	
001	6	1
010	7	1
011	9	1
100	18	2
101	21	2
110	24	2
111	10	4

Figure 34:
Step Response (fast filter ON)

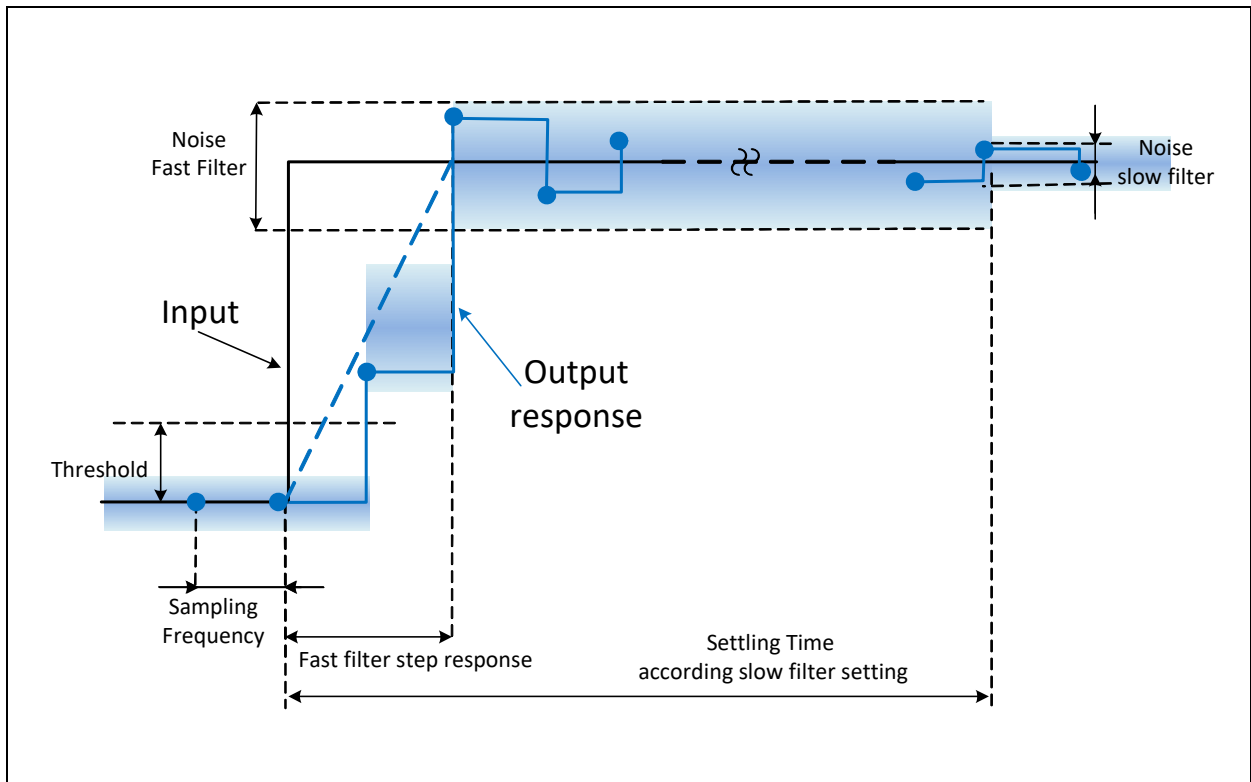

Direction (clockwise vs. counterclockwise)

The AS5600 allows controlling the direction of the magnet rotation with the DIR pin. If DIR is connected to GND (DIR = 0) a clockwise rotation viewed from the top will generate an increment of the calculated angle. If the DIR pin is connected to VDD (DIR = 1) an increment of the calculated angle will happen with counterclockwise rotation.

Figure 35:
Raw Angle in Clockwise Direction

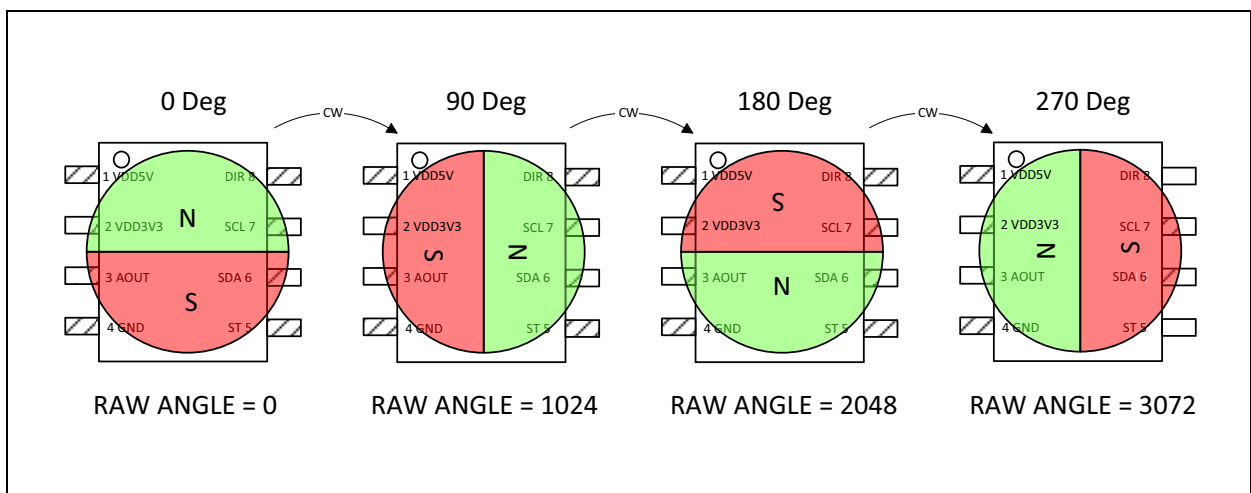

Hysteresis

To avoid any toggling of the output when the magnet is not moving, a 1 to 3 LSB hysteresis of the 12-bit resolution can be enabled with the **HYST** bits in the **CONF** register.

Magnet Detection

As a safety and diagnostic feature, the AS5600 indicates the absence of the magnet. If the measured magnet field strength goes below the minimum specified level (**Bz_ERROR**), the output is driven low, without regard to which output mode has been selected (analog or PWM) and the **MD** bit in the **STATUS** register is 0.

Low Power Modes

A digital state machine automatically manages the low power modes to reduce the average current consumption. Three low power modes are available and can be enabled with the **PM** bits in the **CONF** register. Current consumption and polling times are shown in [Figure 6](#).

Watchdog Timer

The watchdog timer allows saving power by switching into LMP3 if the angle stays within the watchdog threshold of 4 LSB for at least one minute, as shown in [Figure 36](#). The watchdog function can be enabled with the **WD** bit in the **CONF** register.

Figure 36:
Watchdog Timer Function

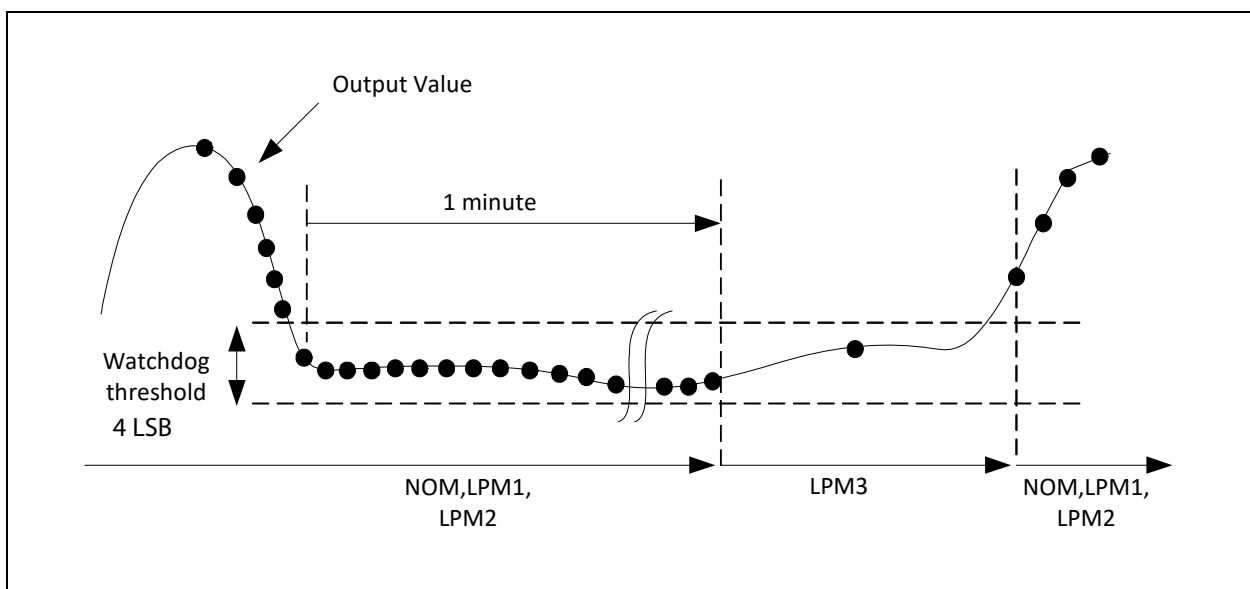

Application Information

Schematic

All required external components are shown below for the reference application diagram. To improve EMC and for remote applications, consider additional protection circuitry.

Figure 37:
Application Diagram for Angle Readout and Programming Through OUT Pin (Option B)

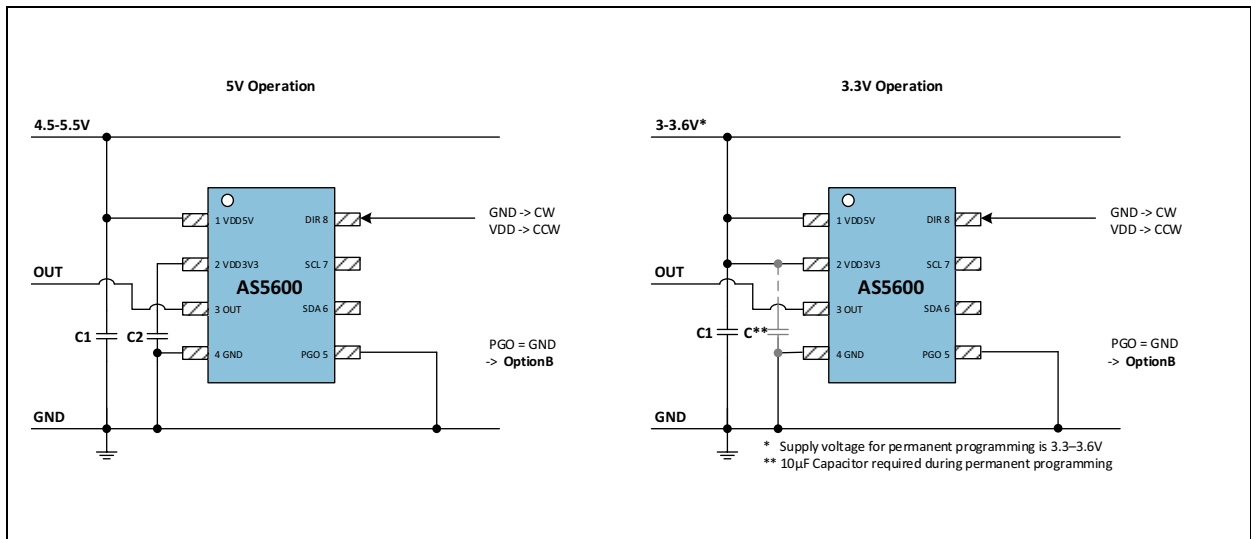

Note(s):

1. Consider that the output is driven high by an internal pull-up resistor during programming through the OUT pin. Disconnect additional external load during the programming procedure.

Figure 38:
Application Diagram for Angle Readout and Programming with I²C (Option A and Option C)

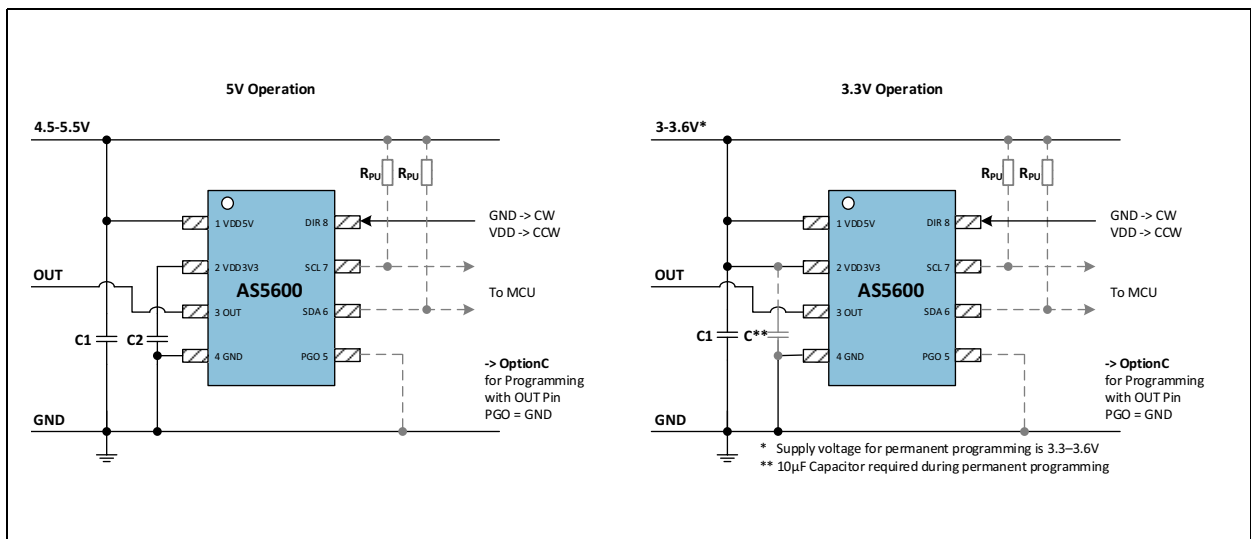

Figure 39:
Recommended External Components

Component	Symbol	Value	Units	Notes
VDD5V buffer capacitor	C1	100	nF	20%
LDO regulator capacitor	C2	1	μ F	20%; < 100 m Ω ; Low ESR ceramic capacitor
Optional pull-up for I ² C bus	RPU	4.7	K Ω	Refer to UM10204 for RPU sizing

Note(s):

1. Given parameter characteristics have to be fulfilled over operation temperature and product lifetime

Magnetic Requirements

The AS5600 requires the magnetic field component B_z perpendicular to the sensitive area on the chip.

Along the circumference of the Hall element circle the magnetic field B_z should be sine-shaped. The magnetic field gradient of B_z along the radius of the circle should be in the linear range of the magnet to eliminate displacement error by the differential measurement principle.

Figure 40:
Magnetic Field B_z and Typical Airgap

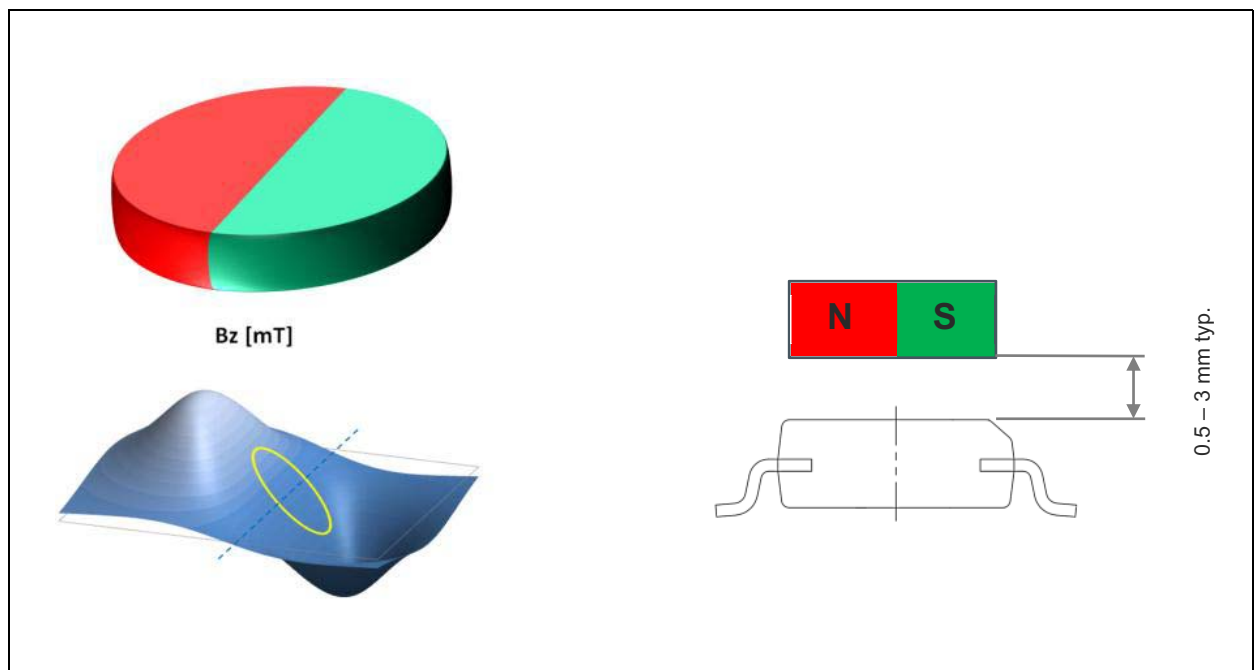

The typical airgap is between 0.5 mm and 3 mm, and it depends on the selected magnet. A larger and stronger magnet allows a larger airgap. Using the AGC value as a guide, the optimal airgap can be found by adjusting the distance between the magnet and the AS5600 so that the AGC value is in the center of its range. The maximum allowed displacement of the rotational axis of the reference magnet from the center of the package is 0.25 mm when using a magnet with a diameter of 6mm.

Mechanical Data

The internal Hall elements are placed in the center of the package on a circle with a radius of 1 mm.

Figure 41:
Hall Element Positions

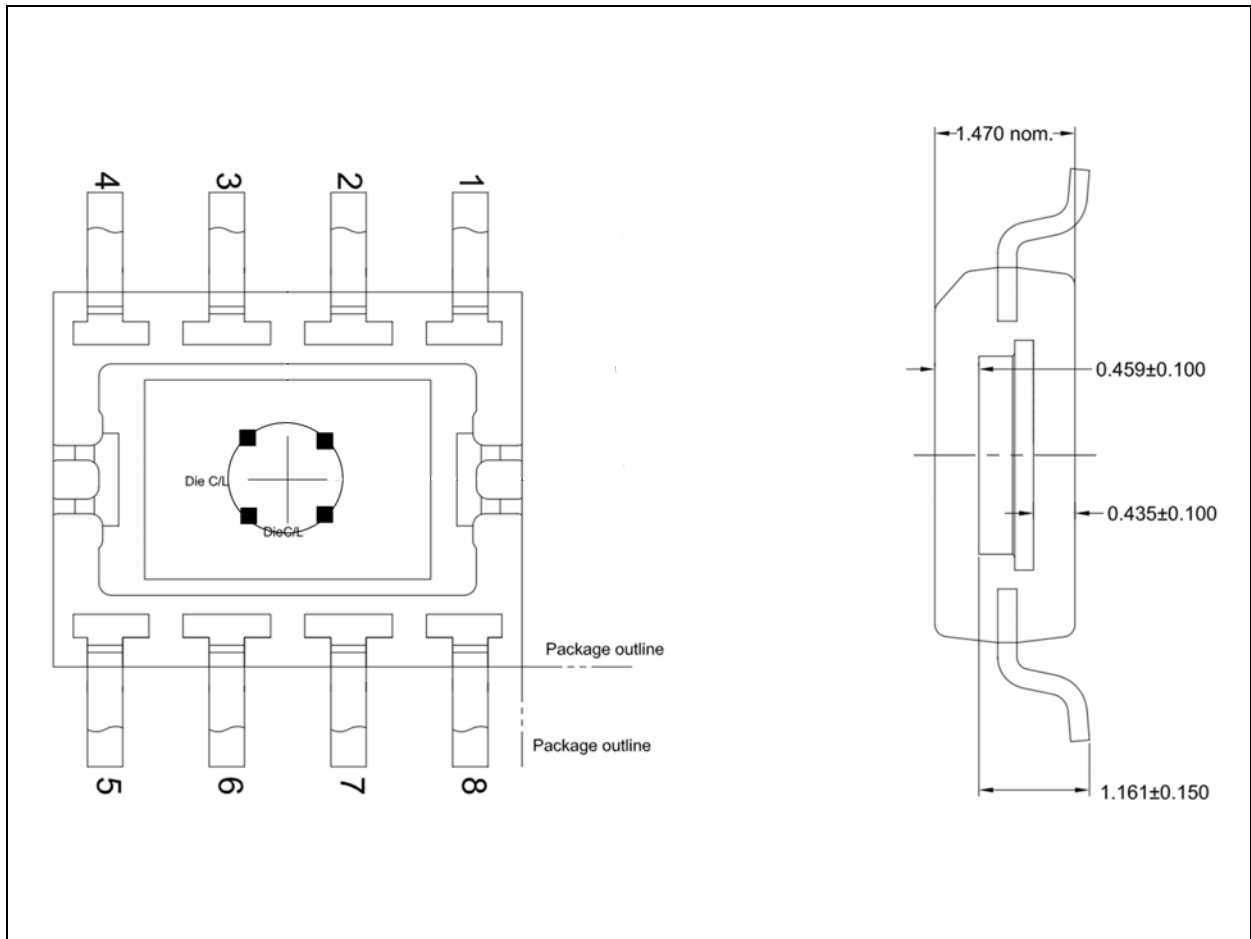

Note(s):

1. All dimensions in mm.
2. Die thickness 356µm nom.

Package Drawings & Markings

Figure 42:
SOIC8 Package Outline Drawing

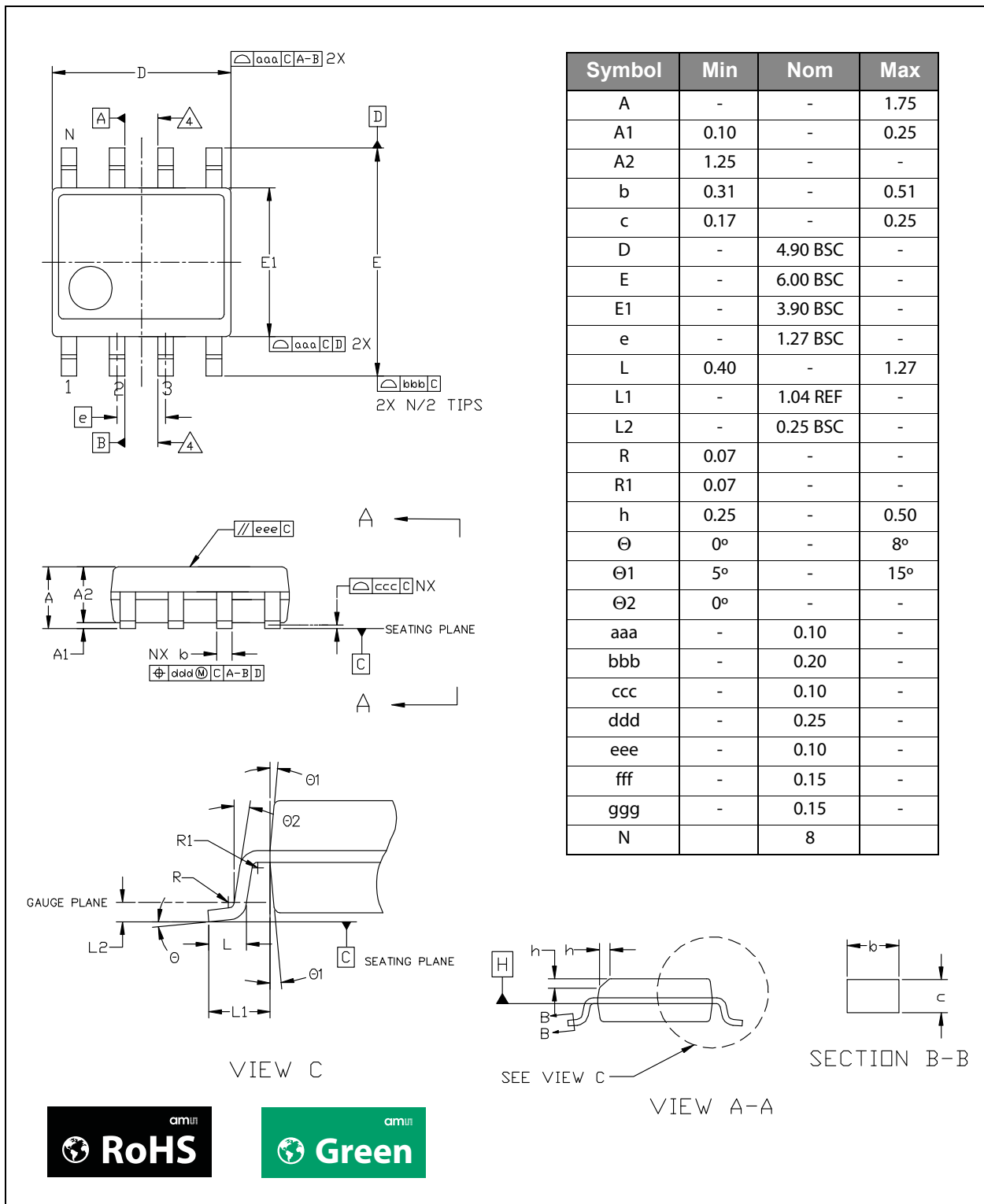

Note(s):

1. Dimensioning & tolerancing conform to ASME Y14.5M-1994.
2. All dimensions are in millimeters. Angles are in degrees.
3. N is the total number of terminals.
4. DATUMS A & B to be determined at DATUM H.

Figure 43:
Package Marking

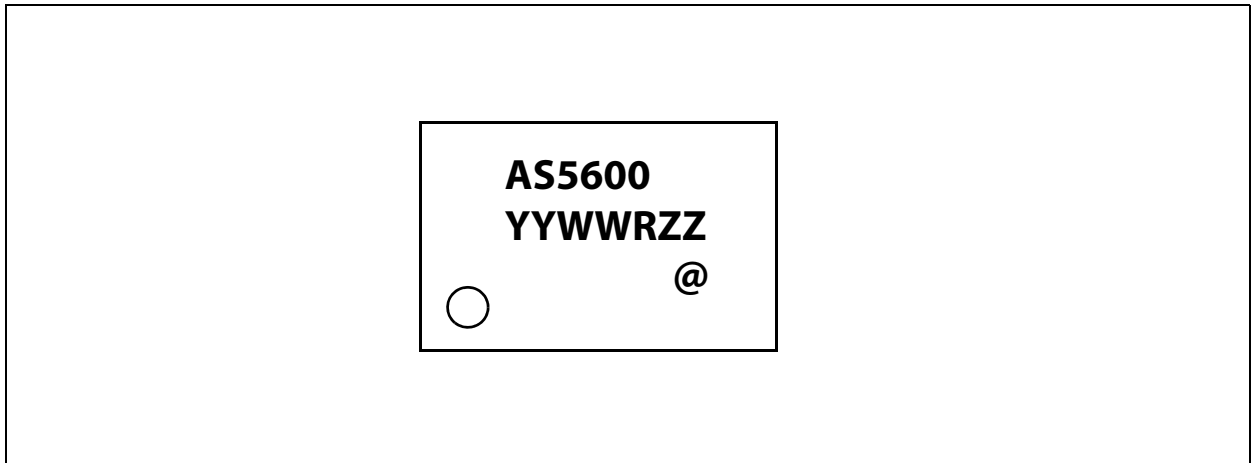

Figure 44:
Packaging Code

YY	WW	R	ZZ	@
Last two digits of the manufacturing year	Manufacturing week	Plant identifier	Free choice/ traceability code	Sublot identifier

Ordering & Contact Information

Figure 45:
Ordering Information

Ordering Code	Package	Marking	Delivery Form	Delivery Quantity
AS5600-ASOT	SOIC-8	AS5600	13" Tape&Reel in dry pack	2500 pcs
AS5600-ASOM	SOIC-8	AS5600	7" Tape&Reel in dry pack	500 pcs

Buy our products or get free samples online at:

www.ams.com/Products

Technical Support is available at:

www.ams.com/Technical-Support

Provide feedback about this document at:

www.ams.com/Document-Feedback

For further information and requests, e-mail us at:

ams_sales@ams.com

For sales offices, distributors and representatives, please visit:

www.ams.com/Contact

Headquarters

ams AG

Tobelbader Strasse 30

8141 Premstaetten

Austria, Europe

Tel: +43 (0) 3136 500 0

Website: www.ams.com

RoHS Compliant & ams Green Statement

RoHS: The term RoHS compliant means that ams AG products fully comply with current RoHS directives. Our semiconductor products do not contain any chemicals for all 6 substance categories, including the requirement that lead not exceed 0.1% by weight in homogeneous materials. Where designed to be soldered at high temperatures, RoHS compliant products are suitable for use in specified lead-free processes.

ams Green (RoHS compliant and no Sb/Br): ams Green defines that in addition to RoHS compliance, our products are free of Bromine (Br) and Antimony (Sb) based flame retardants (Br or Sb do not exceed 0.1% by weight in homogeneous material).

Important Information: The information provided in this statement represents ams AG knowledge and belief as of the date that it is provided. ams AG bases its knowledge and belief on information provided by third parties, and makes no representation or warranty as to the accuracy of such information. Efforts are underway to better integrate information from third parties. ams AG has taken and continues to take reasonable steps to provide representative and accurate information but may not have conducted destructive testing or chemical analysis on incoming materials and chemicals. ams AG and ams AG suppliers consider certain information to be proprietary, and thus CAS numbers and other limited information may not be available for release.

Copyrights & Disclaimer

Copyright ams AG, Tobelbader Strasse 30, 8141 Premstaetten, Austria-Europe. Trademarks Registered. All rights reserved. The material herein may not be reproduced, adapted, merged, translated, stored, or used without the prior written consent of the copyright owner.

Devices sold by ams AG are covered by the warranty and patent indemnification provisions appearing in its General Terms of Trade. ams AG makes no warranty, express, statutory, implied, or by description regarding the information set forth herein. ams AG reserves the right to change specifications and prices at any time and without notice. Therefore, prior to designing this product into a system, it is necessary to check with ams AG for current information. This product is intended for use in commercial applications. Applications requiring extended temperature range, unusual environmental requirements, or high reliability applications, such as military, medical life-support or life-sustaining equipment are specifically not recommended without additional processing by ams AG for each application. This product is provided by ams AG "AS IS" and any express or implied warranties, including, but not limited to the implied warranties of merchantability and fitness for a particular purpose are disclaimed.

ams AG shall not be liable to recipient or any third party for any damages, including but not limited to personal injury, property damage, loss of profits, loss of use, interruption of business or indirect, special, incidental or consequential damages, of any kind, in connection with or arising out of the furnishing, performance or use of the technical data herein. No obligation or liability to recipient or any third party shall arise or flow out of ams AG rendering of technical or other services.

Document Status

Document Status	Product Status	Definition
Product Preview	Pre-Development	Information in this datasheet is based on product ideas in the planning phase of development. All specifications are design goals without any warranty and are subject to change without notice
Preliminary Datasheet	Pre-Production	Information in this datasheet is based on products in the design, validation or qualification phase of development. The performance and parameters shown in this document are preliminary without any warranty and are subject to change without notice
Datasheet	Production	Information in this datasheet is based on products in ramp-up to full production or full production which conform to specifications in accordance with the terms of ams AG standard warranty as given in the General Terms of Trade
Datasheet (discontinued)	Discontinued	Information in this datasheet is based on products which conform to specifications in accordance with the terms of ams AG standard warranty as given in the General Terms of Trade, but these products have been superseded and should not be used for new designs

Revision Information

Changes from 1-05 (2018-May-18) to current revision 1-06 (2018-Jun-20)	Page
Updated Figure 6	5
Updated text under ZPOS/MPOS/MANG Registers	19

Note(s):

1. Page and figure numbers for the previous version may differ from page and figure numbers in the current revision.
2. Correction of typographical errors is not explicitly mentioned.

Content Guide

1	General Description
1	Key Benefits & Features
2	Applications
2	Block Diagram
3	Pin Assignments
4	Absolute Maximum Ratings
5	Electrical Characteristics
5	Operating Conditions
6	Digital Inputs and Outputs
6	Analog Output
7	PWM Output
7	Timing Characteristics
8	Magnetic Characteristics
8	System Characteristics
9	Detailed Description
9	IC Power Management
10	I ² C Interface
10	Supported Modes
10	I ² C Interface Operation
11	I ² C Electrical Specification
12	I ² C Timing
13	I ² C Modes
13	<i>Invalid Addresses</i>
13	<i>Reading</i>
13	<i>Automatic Increment of the Address Pointer for ANGLE, RAW ANGLE and MAGNITUDE Registers</i>
13	<i>Writing</i>
13	<i>Supported Bus Protocol</i>
15	AS5600 Slave Modes
15	<i>Slave Receiver Mode (Write Mode)</i>
16	<i>Slave Transmitter Mode (Read Mode)</i>
17	<i>SDA and SCL Input Filters</i>
18	Register Description
19	ZPOS/MPOS/MANG Registers
19	CONF Register
19	ANGLE/RAW ANGLE Register
20	STATUS Register
20	AGC Register
20	MAGNITUDE Register
20	Non-Volatile Memory (OTP)
20	<i>Burn_Angle Command (ZPOS, MPOS)</i>
21	<i>Burn_Setting Command (MANG, CONFIG)</i>
21	Angle Programming
24	Output Stage
25	Analog Output Mode
27	PWM Output Mode
28	Step Response and Filter Settings
30	Direction (clockwise vs. counterclockwise)
31	Hysteresis
31	Magnet Detection

- 31 Low Power Modes
- 31 Watchdog Timer

- 32 Application Information**
- 32 Schematic
- 33 Magnetic Requirements
- 34 Mechanical Data

- 35 Package Drawings & Markings**
- 37 Ordering & Contact Information**
- 38 RoHS Compliant & ams Green Statement**
- 39 Copyrights & Disclaimer**
- 40 Document Status**
- 41 Revision Information**

Looking for pricing, stock, or lifecycle information?

Click below to explore more details on WIN SOURCE:

- ⊖ [View AS5600-SO_EK_AB on WIN SOURCE](#)
- ⊖ [ams Information](#)

Optimize Your Supply Chain with WIN SOURCE Solutions

- ✓ Global Sourcing Solution
- ✓ Obsolete Management
- ✓ Cost Control Management
- ✓ Shortage Management
- ✓ Alternative Solution
- ✓ Excess Inventory Management