



THE DATASHEET OF AS5011 DB EASYPOINT



AS5011

Low power Integrated Hall IC for human interface applications

DEMOBOARD AND SOFTWARE OPERATION MANUAL

1 General Description

The AS5011 is a complete Hall Sensor IC for smart navigation key applications to meet the low power requirements and host SW integration challenges for products such as cell phones and smart handheld devices. Due to the on chip processing engine, system designers are not tasked with integrating complex SW algorithms on their host processor thus leading to rapid development cycles.

The AS5011 single-chip IC includes 4 integrated Hall sensing elements for detecting up to $\pm 2\text{mm}$ lateral displacement, high resolution ADC, XY coordinate and motion detection engine combined with a smart power management controller.

The X and Y positions coordinates and magnetic field information for each Hall sensor element is transmitted over a 2-wire I²C compatible interface to the host processor.

The AS5011 is available in a small 16-pin 5x5mm QFN package and specified over an operating temperature of -20 to +80°C.

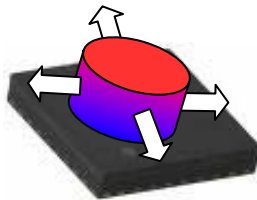

2 The AS5011 Demoboard

The AS5011 demoboard consists of an input module and an USB interface PCB. The whole system is USB powered.

Once plugged on a PC running Windows, the AS5011 demoboard will work as a standard HID mouse. Pressing down the knob of the module works as a left mouse click.

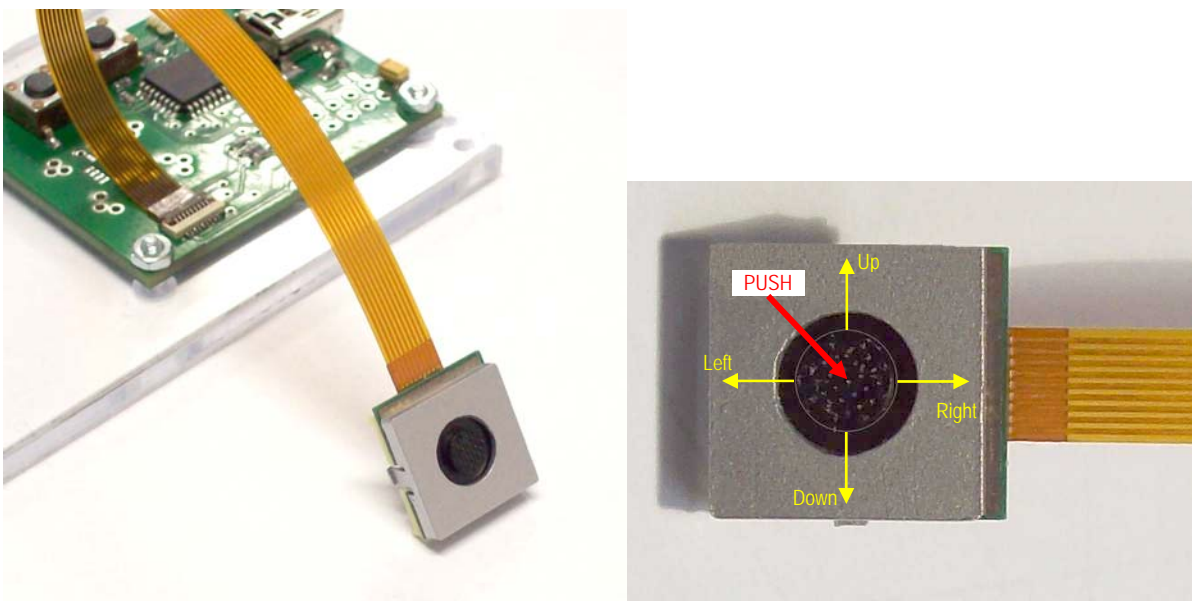

Figure 1: AS5011 pointing module

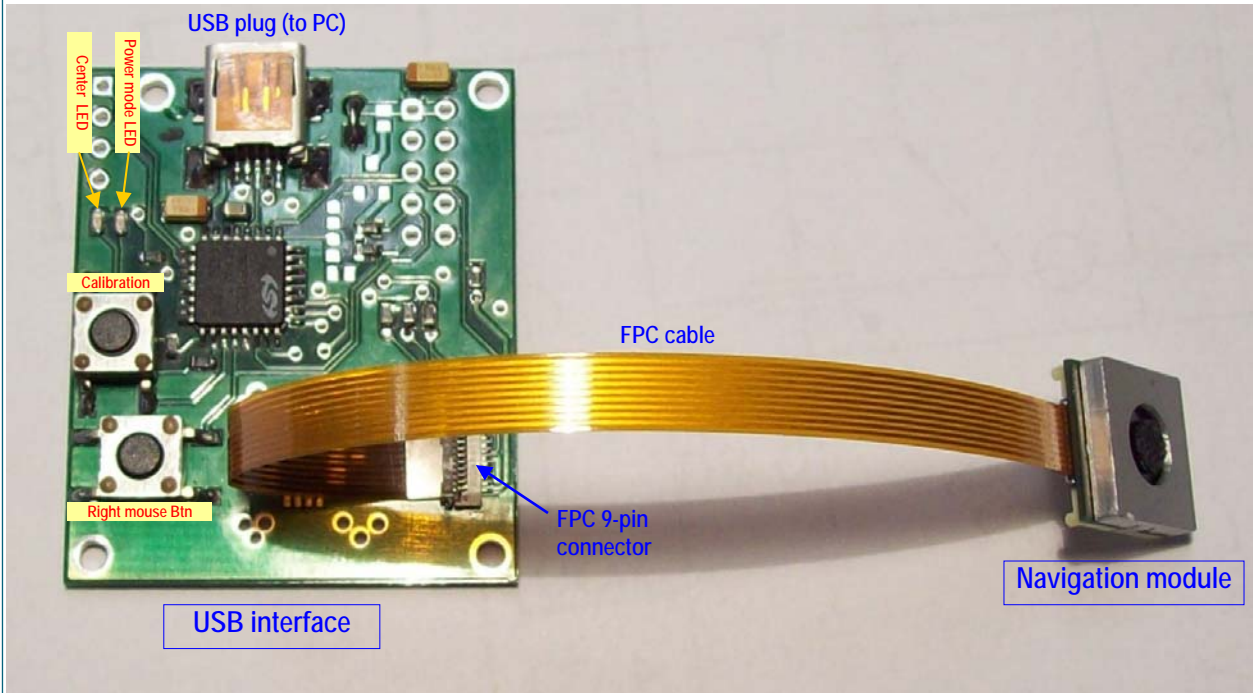

Figure 2: AS5011 demoboard

As the AS5011 is considered as a standard HID mouse in Windows, a right mouse button has been implemented.

In order to compensate an inaccurate centering of the module's knob, an automatic centering calibration is performed each time the demoboard is plugged on the PC. The calibration procedure can be manually done by clicking the calibration knob on the USB interface.

If this button is kept pressed, the mouse pointer doesn't move, but can be controlled by the normal mouse or touchpad of the PC. The AS5011 Mouse and a standard mouse can work in parallel if they are connected at the same time.

Two LEDs are present on the USB interface:

- **Power Mode LED:** Indicates the actual power mode configured in the AS5011, and automatically updated.
 - Power mode LED off: Shutdown mode (50uA current)
 - Power mode LED on: Low power mode (200uA current)
- **Center LED:** Indicates that the knob is centered on the (0,0) corrected position

3 AS5011 Mouse pointer

Due to the high number of velocity steps provided by the AS5011 to the Windows mouse driver, the pointer displacement speed can be too high to control it properly.

The mouse pointer speed can be configured in Windows Settings → Control Panel → Mouse

Depending on the PC and the user's feeling, speed level 1-level 3 are the best values.

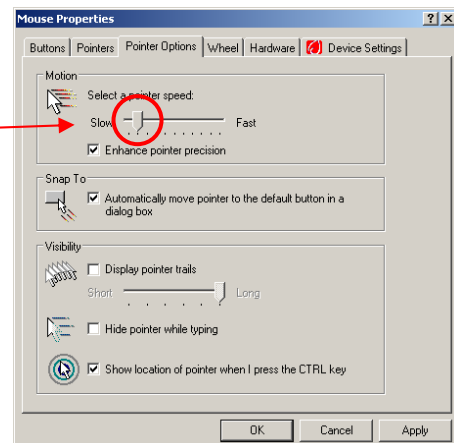

Figure 3: Windows Mouse control panel

4 AS5011 Mouse GUI Software

4.1 Getting Started

As the AS5011 Demoboard works like a standard HID mouse, no software is needed to test it. But for more flexibility and in order to become familiar with the principle of the AS5011 sensor, the *AS5011 Mouse GUI* software allows to modify the device registers, read the magnet coordinates and change some attribute of the mouse.

In order to get started, you need:

- The AS5011 Mouse GUI Software installer
- a Win-XP® or Windows Vista® operating system
- one free USB slot on your PC to connect the demoboard

4.2 Installing the Software

1. Before plugging the demoboard on the PC, execute the AS5011 Mouse installer, and follow the instructions.
2. Once the installation is complete, plug the AS5011 demoboard into the PC with the USB cable.
3. If it is the first time the AS5011 demoboard is connected on the computer, Windows will look for the driver "Silnt.sys". Search for the file manually, from a specific location:

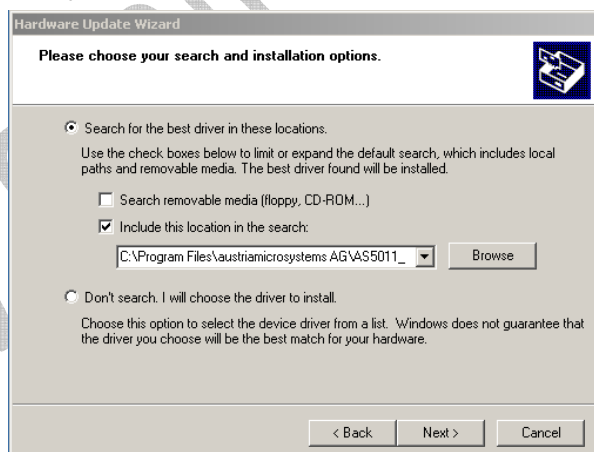
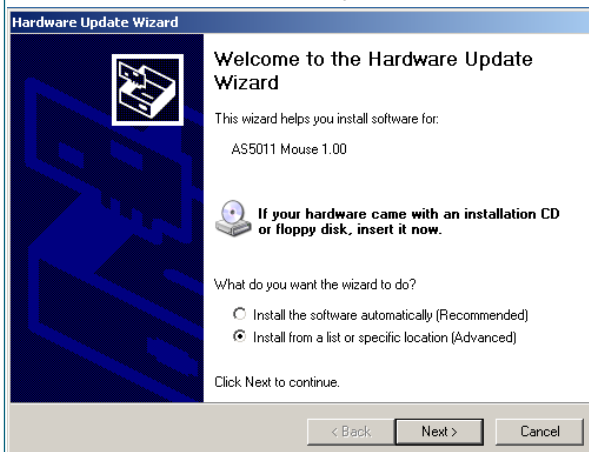

Enter the path: C:\Program Files\ austriamicrosystems AG\AS5011_Mouse\Driver, where the Silnt.sys file is located.

4.3 Software Usage

Before starting the software the board needs to be connected to the PC.

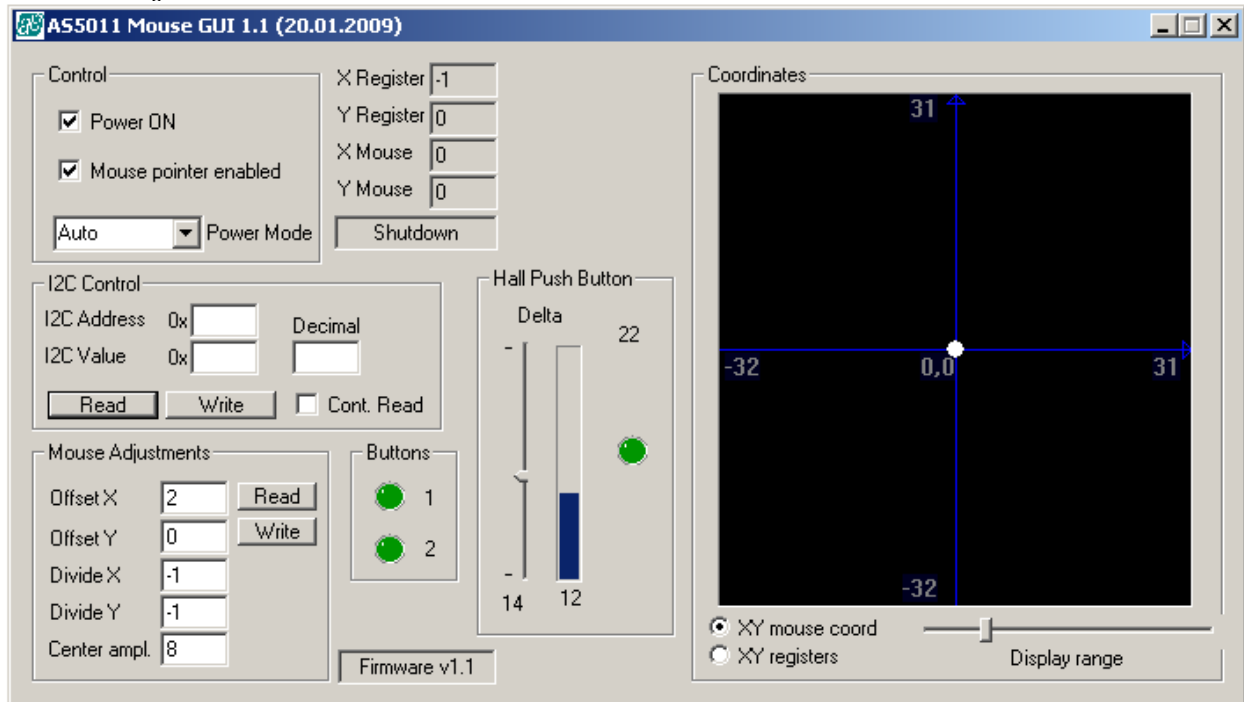

Figure 4: AS5011 Mouse GUI

- **X_Register, Y_Register:** Are the raw X and Y register values from the AS5011.
- **X_Mouse, Y_Mouse:** Are the corrected XY coordinates sent to Windows for the mouse pointer acceleration. The correction is made by the "Mouse Adjustments" values described below.
- **Shutdown / Low Power field:** Is the realtime power mode configured in the AS5011.
- **Power ON:** If unchecked, the USB communication is disabled.
- **Mouse pointer enabled:** If unchecked, the USB communication goes on, the registers are still updated. But the mouse pointer as the X_Mouse/Y_Mouse aren't updated anymore. This mode is used in order to test the demoboard without interacting the Windows mouse pointer.
- **Power Mode:** Configures the AS5011 to the following power modes:
 - **Auto:** The AS5011 power mode is automatically set, depending on the position of the knob. If X_Mouse=0 and Y_Mouse=0, then the AS5011 is in shutdown mode and the X_Registers/Y_Registers are not updated, otherwise it will be set in low power mode.
 - **Shutdown:** Sets manually the AS5011 in Shutdown mode. The registers are not updated if X_Mouse=0 and Y_Mouse=0 (knob around the center)
 - **Low Power:** Sets manually the AS5011 in Low Power mode. The X_Register Y_Register are updated everytime.
- **I2C Control:** The AS5011 registers can be read or written.
 - To READ a register, enter the register address in hex format, and click on the READ button
 - To write a register, enter the register address in hex format, enter the value in hex format or decimal format (unsigned), and click on the WRITE button. The AS5011 pointed register will be immediately updated.
- **Mouse adjustments:** The mouse coordinates (X_Mouse/Y_Mouse) send to the Windows mouse driver can be adjusted with those parameters.
Here is the calculation of X_mouse (the same is applied for Y_Mouse):

```
If (X_Register + Offset_X) > Center_ampl →  
    X_Mouse = (X_Register + Offset_X - Center_ampl) / Coord_divider_X  
Else if (X_Register + Offset_X) < Center_ampl →  
    X_Mouse = (X_Register + Offset_X + Center_ampl) / Coord_divider_X  
Else X_Mouse = 0
```

- Offset_X (signed integer): Adds an offset on the X register read from the AS5011. This offset is used to correct the center value of the knob. This Offset_X value is set at power-up.
 - Divide_X (signed integer): Divide the corrected X_Register to decrease the resolution on the X axis. Using a negative value will invert the direction of the mouse pointer.
 - Center_ampl. (unsigned integer): Defines a range around the center where the resulting X_Mouse will remain at 0. If Center_ampl. = 8, then the knob can move around +8 decimals around the center (-Offset_X) and the mouse will not move. This can be used to avoid the mouse moving while clicking on the knob.
- **Hall push button:** This algorithm can determine if the knob has been pushed only by reading the center hall element of the AS5011. That means no contact is used to achieve a push button function. The vertical slider is the threshold of the push detection. If the delta value is higher than the slider value, then the pushed status has been detected.
 - **Buttons status 1 & 2:** Are the status of the left push button (the module knob) and the right mouse button on the USB interface.
 - **Coordinates:** Shows the position of the knob graphically. The corrected XY_Mouse position (by default) or the real XY_Registers position can be represented.

The coordinates can be zoomed by the display range slider. A correct value for the actual navigation module is 32.

5 AS5011 Demoboard hardware

5.1 USB interface

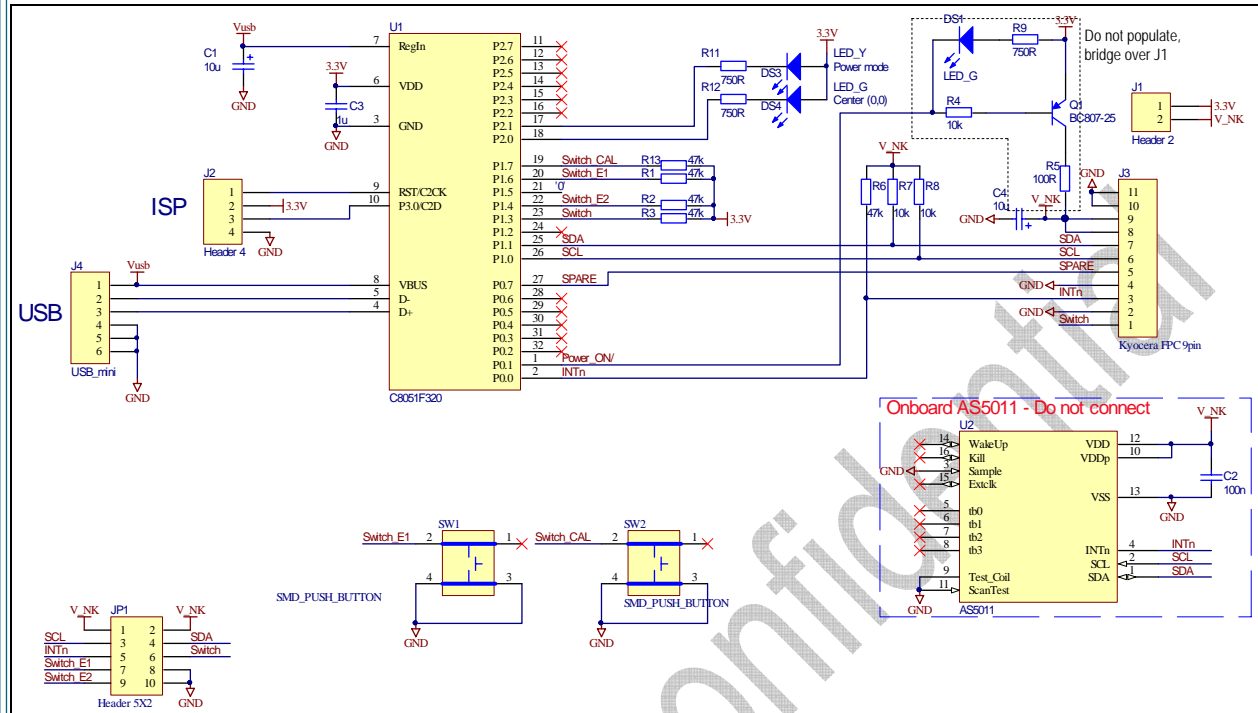

Figure 5: AS5011_NB_1.1 USB Interface schematics

The microcontroller C8051C320 (U1) from SiLabs includes an on-chip USB interface. The firmware is stored in its internal flash memory (16kB).

The whole power supply is taken from the USB bus by the microcontroller, and converts it internally to 3.3V. No external LDO is required.

Connector J1 is the navigation module connection through a 0.5mm pitch 0.3mm thick FPC cable. The Module power supply is 3.3V for both core and IO.

Connector JP1 is used to easily connect an external navigation module.

Connector J2 is used for ISP programming of the microcontroller only.

All the switches (module dome switch: left mouse button, SW1: right mouse button, SW2: Calibration button) are connected directly to the microcontroller.

5.2 Navigation Module

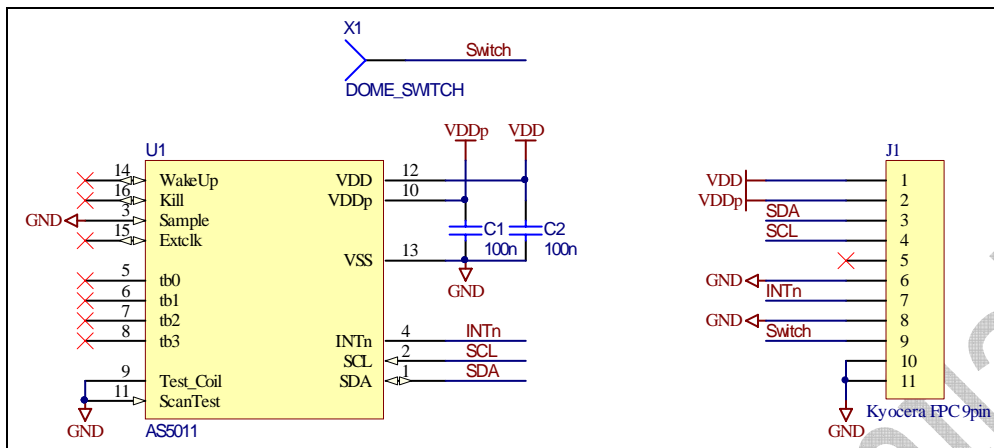

Figure 6: AS5011_NK_1.0 navigation module schematics

The I²C serial interface (SCL, SDA) is controlled by the C8051 microcontroller. The interrupt output INTn is connected directly to the interrupt input the MCU.

The module has 2 separate power supplies: VDD (core: 2.7V~3.6V) and VDDp (IO: 1.8V~3.6V). Connected to the USB interface, both power supplies are connected to 3.3V.

The push button signal from the dome switch placed under the magnet is connected to the FPC cable pin 9.

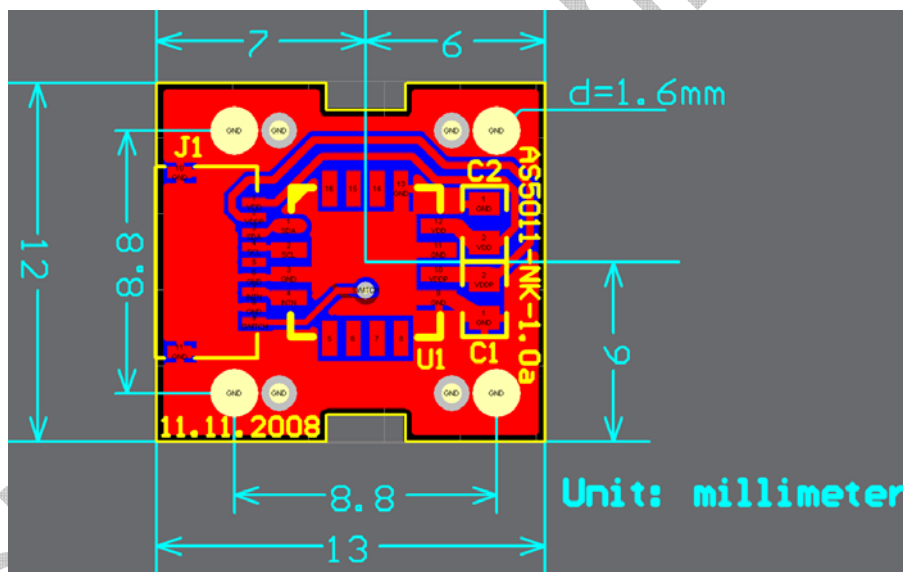

Figure 7: AS5011_NK_1.0 navigation module PCB, bottom view

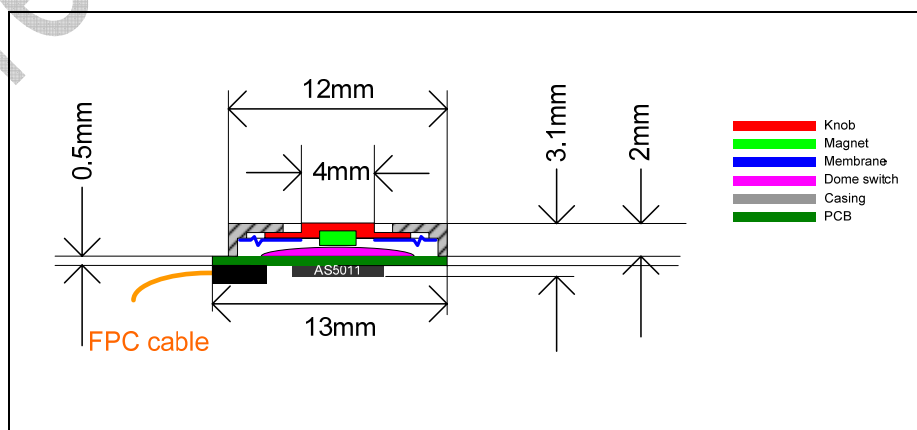

Figure 8: Module mechanics stack up

Table of contents

1	General Description	1
2	The AS5011 Demoboard	1
3	AS5011 Mouse pointer	2
4	AS5011 Mouse GUI Software	3
4.1	Getting Started	3
4.2	Installing the Software	3
4.3	Software Usage	4
5	AS5011 Demoboard hardware	6
5.1	USB interface	6
5.2	Navigation Module	7
	Table of contents	8
	Copyrights	9
	Disclaimer	9
	Contact Information	9

Copyrights

Copyright © 1997-2009, austriamicrosystems AG, Schloss Premstaetten, 8141 Unterpemstaetten, Austria-Europe. Trademarks Registered ®. All rights reserved. The material herein may not be reproduced, adapted, merged, translated, stored, or used without the prior written consent of the copyright owner. All products and companies mentioned are trademarks or registered trademarks of their respective companies.

Disclaimer

Devices sold by austriamicrosystems AG are covered by the warranty and patent indemnification provisions appearing in its Term of Sale. austriamicrosystems AG makes no warranty, express, statutory, implied, or by description regarding the information set forth herein or regarding the freedom of the described devices from patent infringement. austriamicrosystems AG reserves the right to change specifications and prices at any time and without notice. Therefore, prior to designing this product into a system, it is necessary to check with austriamicrosystems AG for current information. This product is intended for use in normal commercial applications. Applications requiring extended temperature range, unusual environmental requirements, or high reliability applications, such as military, medical life-support or lifesustaining equipment are specifically not recommended without additional processing by austriamicrosystems AG for each application. The information furnished here by austriamicrosystems AG is believed to be correct and accurate. However, austriamicrosystems AG shall not be liable to recipient or any third party for any damages, including but not limited to personal injury, property damage, loss of profits, loss of use, interruption of business or indirect, special, incidental or consequential damages, of any kind, in connection with or arising out of the furnishing, performance or use of the technical data herein. No obligation or liability to recipient or any third party shall arise or flow out of austriamicrosystems AG rendering of technical or other services.

Contact Information

Headquarters

austriamicrosystems AG
A-8141 Schloss Premstaetten, Austria
Tel: +43 (0) 3136 500 0
Fax: +43 (0) 3136 525 01

For Sales Offices, Distributors and Representatives, please visit:
<http://www.austriamicrosystems.com>

Looking for pricing, stock, or lifecycle information?

Click below to explore more details on WIN SOURCE:

- ⊖ [View AS5011 DB EASYPOINT](#) on WIN SOURCE
- ⊖ [ams](#) Information

Optimize Your Supply Chain with WIN SOURCE Solutions

- ✓ Global Sourcing Solution
- ✓ Obsolete Management
- ✓ Cost Control Management
- ✓ Shortage Management
- ✓ Alternative Solution
- ✓ Excess Inventory Management