



**THE DATASHEET OF  
AS3685A-DB-DFN**



# AS3685A/AS3685B

## Ultra Small High Efficiency 1000mA Charge Pump for White LED Flash

### General Description

The AS3685 is low noise high efficiency capacitive charge pump with 1:1, 1:1.5 and 1:2 operating modes in a small 3x3mm DFN10 or a tiny 2x1.5mm WL-CSP (Wafer Level Chip Scale Package) package. It can drive one flash LED at up to 1000mA current. It supports flash/torch and indicator mode for the flash LED.

Additionally the AS3685 limits the flash time automatically to protect the flash LED.

*Ordering Information and Content Guide appear at end of datasheet.*

### Key Benefits & Features

The benefits and features of AS3685A/AS3685B, Ultra Small High Efficiency 1000mA Charge Pump for White LED Flash are listed below:

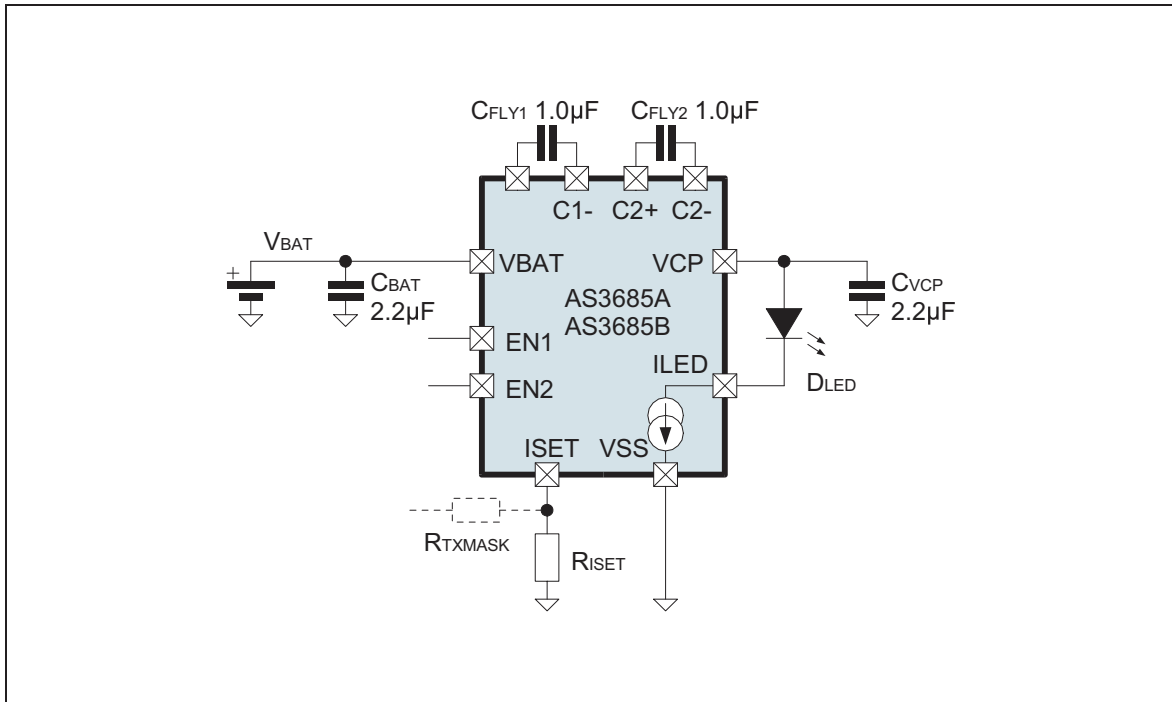
**Figure 1:**  
Added Value Of Using AS3685A/AS3685B

Benefits	Features
<ul style="list-style-type: none"> <li>System safety</li> </ul>	<ul style="list-style-type: none"> <li>High efficiency capacitive charge pump with 1:1, 1:1.5 and 1:2 modes therefore maximum input current is exactly controlled.</li> <li>Overtemperature protection</li> <li>Automatic 800ms flash timeout to protect the flash LED</li> </ul>
<ul style="list-style-type: none"> <li>Drive LED at high brightness for better pictures</li> </ul>	<ul style="list-style-type: none"> <li>Up to 1000mA LED Current</li> </ul>
<ul style="list-style-type: none"> <li>Flexible selection of interface type</li> </ul>	<ul style="list-style-type: none"> <li>Two device variants:               <ul style="list-style-type: none"> <li>AS3685A: Direct control to select three currents</li> <li>AS3685B: Single pin interface or two pin interface with strobe input; 17 different currents can be selected</li> </ul> </li> </ul>
<ul style="list-style-type: none"> <li>Flexible package options</li> </ul>	<ul style="list-style-type: none"> <li>DFN10 (3x3mm) 10 pins + exposed pad</li> <li>WL-CSP (2x1.5mm) 3x4 balls 0.5mm pitch</li> </ul>

### Applications

The AS3685A/AS3685B, Ultra Small High Efficiency 1000mA Charge Pump for White LED Flash is ideal for Flash / Torch for Mobile Phones, Digital Cameras and PDAs.

**Figure 2:**  
Application Diagram of AS3685A/AS3685B



## Pin Assignment

### DFN10 (3x3mm)

Figure 3:  
Pin Diagram DFN10 (3x3mm)

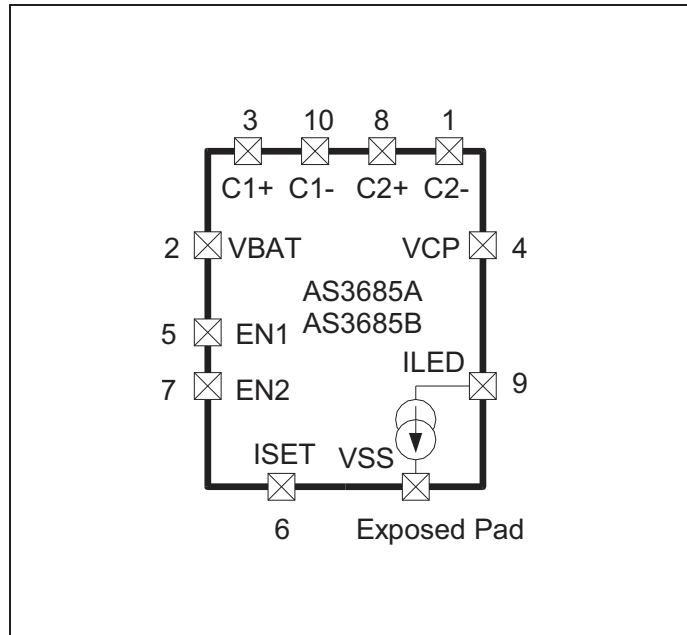


Figure 4:  
Pin Description DFN10 (3x3mm)

Pin Number	Pin Name	Type	Description
1	C2-	AI/O	Flying Capacitor 2 connection – connect 1 $\mu$ F ceramic capacitor $C_{FLY2}$ between C2- and C2+
2	VBAT	S	Battery Supply Voltage
3	C1+	AI/O	Flying Capacitor 1 connection – connect 1 $\mu$ F ceramic capacitor $C_{FLY1}$ between C1- and C1+
4	VCP	AI/O	Charge Pump Output voltage – connect flash LED anode to this pin and add $C_{VCP}$ capacitor with 2.2 $\mu$ F to VSS
5	EN1	DI	Digital Control Signal EN1
6	ISET	AI/O	Current Generator input pin – connect current set resistor $R_{ISET}$ between this pin and VSS (and optional $R_{TXMASK}$ )
7	EN2	DI	Digital Control Signal EN2

Pin Number	Pin Name	Type	Description
8	C2+	AI/O	Flying Capacitor 2 connection – connect 1 $\mu$ F ceramic capacitor C <sub>FLY2</sub> between C2- and C2+
9	ILED	AI/O	Current Source input pin – connect flash LED cathode to this pin
10	C1-	AI/O	Flying capacitor 1 connection – connect 1 $\mu$ F ceramic capacitor C <sub>FLY1</sub> between C1- and C1+
Exposed Pad	VSS	S	Ground Connection – a proper thermal connection with several vias to the ground plane is recommended

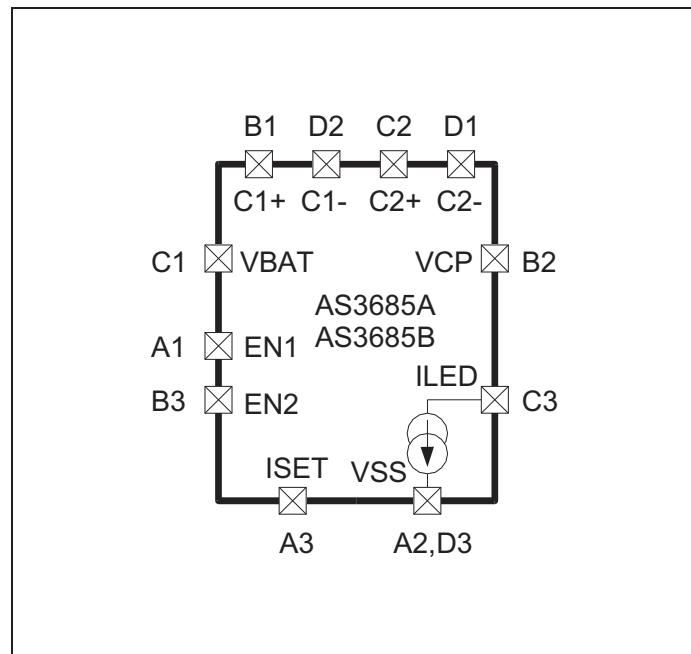
**Note(s):**

1. Pin Type Descriptions:

**AI/O:** Analog Pin

**D:** Digital Input

**S:** Supply Pin

**WL-CSP (2x1.5mm)**
**Figure 5:**  
**WL-CSP (2x1.5mm) Pin Diagram**


**Figure 6:**  
**Pin Description WL-CSP (2x1.5mm)**

Pin Number	Pin Name	Type	Description
A1	EN1	DI	Digital Control Signal EN1
A2	VSS	S	Ground Connection – a proper thermal connection to the ground plane is recommended
A3	ISET	AI/O	Current Generator input pin – connect current set resistor $R_{ISET}$ between this pin and VSS (and optional $R_{TXMASK}$ )
B1	C1+	AI/O	Flying Capacitor 1 connection – connect $1\mu\text{F}$ ceramic capacitor $C_{FLY1}$ between C1- and C1+
B2	VCP	AI/O	Charge Pump Output voltage – connect flash LED anode to this pin and add $C_{VCP}$ capacitor with $2.2\mu\text{F}$ to VSS
B3	EN2	DI	Digital Control Signal EN2
C1	VBAT	S	Battery Supply Voltage
C2	C2+	AI/O	Flying Capacitor 2 connection – connect $1\mu\text{F}$ ceramic capacitor $C_{FLY2}$ between C2- and C2+
C3	ILED	AI/O	Current Source input pin – connect flash LED cathode to this pin
D1	C2-	AI/O	Flying Capacitor 2 connection – connect $1\mu\text{F}$ ceramic capacitor $C_{FLY2}$ between C2- and C2+
D2	C1-	AI/O	Flying capacitor 1 connection – connect $1\mu\text{F}$ ceramic capacitor $C_{FLY1}$ between C1- and C1+
D3	VSS	S	Ground Connection – a proper thermal connection to the ground plane is recommended

**Note(s):**

1. Pin Type Descriptions WL-CSP (2x1.5mm):

**AI/O:** Analog Pin

**DI:** Digital Input

**S:** Supply Pin

## Absolute Maximum Ratings

Stresses beyond those listed in [Absolute Maximum Ratings](#) may cause permanent damage to the device. These are stress ratings only, and functional operation of the device at these or any other conditions beyond those indicated in [Electrical Characteristics](#) is not implied. Exposure to absolute maximum rating conditions for extended periods may affect device reliability.

**Figure 7:**  
Absolute Maximum Ratings

Symbol	Parameter	Min	Max	Units	Comments
$V_{BATMAX}$	Maximum Supply Voltage	-0.3	7.0	V	
$I_{IN}$	Input Pin Current without causing latchup	-25	+25	mA	At 25°C, according to JEDEC 17
$T_{STRG}$	Storage Temperature Range	-55	125	°C	
$RH_{NC}$	Relative Humidity (non-condensing)	5	85	%	
$ESD_{HBM}$	Electrostatic Discharge (Human Body Model)	±1000		V	MIL 883 E Method 3015
$P_T$	Total Continuous Power Dissipation		1.14	W	DFN10 (3x3mm), $T_{AMB} = 70^{\circ}C$ <sup>(1)</sup>
			1.02	W	WL-CSP (2x1.5mm), $T_{AMB} = 70^{\circ}C$ <sup>(1)</sup>
$P_{DERATE}$	PT Derating Factor <sup>(2)</sup>		16.3	mW/°C	DFN10 (3x3mm)
			14.7	mW/°C	WL-CSP (2x1.5mm)
$T_{JUNC}$	Junction Temperature		150	°C	
$T_{BODY}$	Body Temperature during Soldering		260	°C	According to IPC/JEDEC J-STD-020C
$MSL$	Moisture sensitivity level	1			WLCSP package; Represents a max. floor life time of unlimited hours
		3			DFN package; Represents a max. floor life time of 168 hours

**Note(s):**

- Depending on actual PCB layout and PCB used; for peak power dissipation during flashing see document 'AS3685 Thermal Measurements'.  
For 1A flash current see application notes 'AN3685\_1Aflash' and 'AN3685\_1Aflash\_thermal\_1v0'.
- The PT derating factor changes the total continuous power dissipation, if the ambient temperature is different to 70°C. Therefore for e.g. 85°C calculate  $PT_{85^{\circ}C} = PT - P_{DERATE} * (85^{\circ}C - 70^{\circ}C)$ .

## Electrical Characteristics

All limits are guaranteed. The parameters with minimum and maximum values are guaranteed with production tests or SQC (Statistical Quality Control) methods.

**Figure 8:**  
Operating Conditions

Symbol	Parameter	Min	Typ	Max	Units	Note
V <sub>BAT</sub>	Battery Supply Voltage	3.0	3.6	5.5	V	Supply voltage range
V <sub>BATFUNC</sub>	Battery Supply Voltage (functionally working)	2.6			V	AS3685 functionally working, but not all parameters fulfilled
I <sub>BAT</sub>	Operating Current			0.4	A	Depending on load current and charge pump mode
				2.0	A	Limited lifetime, max 20,000s
T <sub>AMB</sub>	Ambient Temperature	-30	25	85	°C	
I <sub>OFF</sub>	Off Mode Current		1.0	4.0	μA	EN1 = 0, EN2 = 0; V <sub>BAT</sub> ≤ 4.2V
I <sub>OPERATING</sub>	Power Consumption (without load)		0.85		mA	1:1 Mode
			6.6		mA	1:1.5 Mode
			8.1		mA	1:2 Mode

**Figure 9:**  
Charge Pump Characteristics

Symbol	Parameter	Min	Typ	Max	Units	Note
V <sub>CP<sub>OUT</sub></sub>	V(VCP) Output Voltage (without load – do not short to VSS)			V <sub>BAT</sub> × CP-mode	V	CP-mode is 1, 1.5 or 2 (automatically selected)
	Output Limitation		5.4	5.6		Internally limited
R <sub>CP</sub>	Charge Pump Effective Resistance		0.28	0.53	Ω	1:1 Mode V <sub>BAT</sub> = 3.6V, I <sub>CP<sub>OUT</sub></sub> = 200mA
			1.37	2.00	Ω	1:1.5 Mode V <sub>BAT</sub> = 3.3V, I <sub>CP<sub>OUT</sub></sub> = 500mA, T <sub>JUNCTION</sub> ≤ 85°C
			1.95	2.44	Ω	1:2 Mode V <sub>BAT</sub> = 3.0V, I <sub>CP<sub>OUT</sub></sub> = 700mA, T <sub>JUNCTION</sub> ≤ 85°C
Eta	Efficiency	75		93	%	V <sub>in</sub> = 3.0V-4.5V, I <sub>out</sub> = 100mA (charge pump alone)
V <sub>RIPPLE</sub>	Output Ripple Voltage		100		mVpp	V <sub>in</sub> = 3.0-4.5V, I <sub>out</sub> = 350mA,

Symbol	Parameter	Min	Typ	Max	Units	Note
fclk	Operating Frequency	-20%	1.0	+20%	MHz	
t <sub>UP_DEB_LONG</sub>	Initial Mode Switching Debounce Time		256		μs	Mode switching up-debounce time after enabling of the charge pump or after mode switching between 1:1 to 1:1.5
t <sub>UP_DEB</sub>	Mode Switching Debounce Time		16		μs	Mode switching up-debounce time in normal operation

**Figure 10:**  
Current Source (Sink) Characteristics

Symbol	Parameter	Min	Typ	Max	Units	Note
I <sub>LED</sub>	Output Current Range		700	1000	mA	700mA: R <sub>ISET</sub> = 14.2kΩ 1000mA: R <sub>ISET</sub> = 10kΩ
I <sub>ACCURACY</sub>	Current Setting Accuracy	-10%	500	+10%	mA	Measured with R <sub>ISET</sub> = 19.9kΩ and maximum flash current
V <sub>ISET</sub>	Current Generator Set Point Voltage (pin ISET)		1.3		V	I <sub>ISET</sub> = V <sub>ISET</sub> / R <sub>ISET</sub> if the resulting bias current is higher than 200μA (typ.), the current source is disabled
I <sub>ISET</sub>	Current Generator Operating Range	10.0		130	μA	
I <sub>FLASH2ISET</sub>	Flash Current to Bias Current Ratio		7650		A/A	AS3685A, EN1=1, EN2=1 or AS3685B at full flash current (700mA with R <sub>ISET</sub> = 14.2kΩ)
I <sub>TORCH2ISET</sub>	Torch Current to Bias Current Ratio		1639		A/A	AS3685A, EN1=0, EN2=1 (150mA with R <sub>ISET</sub> = 14.2kΩ)
V <sub>SWITCH</sub>	Mode Switching Threshold on V(I <sub>LED</sub> ) between 1:1 → 1:1.5 and 1:1.5 → 1:2		400		mV	AS3685A, EN1=1, EN2=1 or AS3685B with I <sub>LED</sub> >350mA (with R <sub>ISET</sub> = 14.2kΩ)
		150	200	250	mV	All lower currents

**Figure 11:**  
**Digital Interface Characteristics**

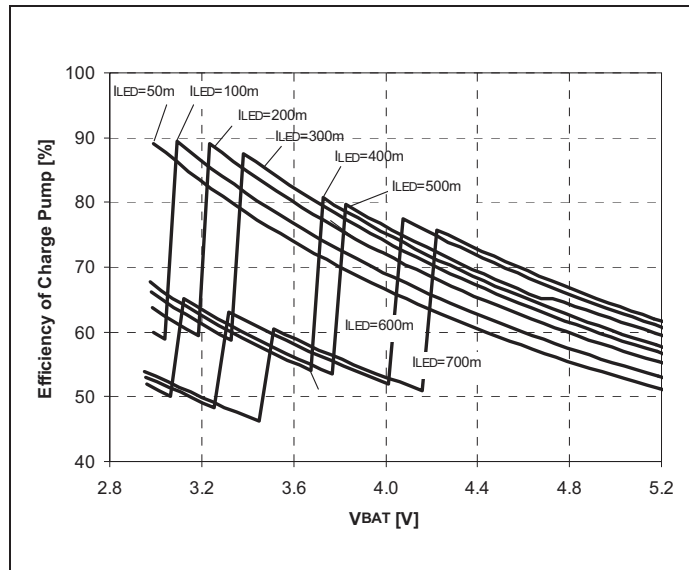
Symbol	Parameter	Min	Typ	Max	Units	Note
$V_{IH}$	High Level Input Voltage	1.5		VBAT	V	For Pins EN1 and EN2  Do not leave EN1 and EN2 floating (47k $\Omega$ pulldowns can be used)
$V_{IL}$	Low Level Input Voltage	0.0		0.5	V	
$I_{LEAKAGE}$	Input Pin Leakage Current	-10		10	$\mu$ A	
$t_{PULSEWIDTH}$	Pulsewidth for Signals on EN1 and EN2 (high or low pulses)	1.0		unlimited	$\mu$ s	

**Figure 12:**  
**Protection Functions**

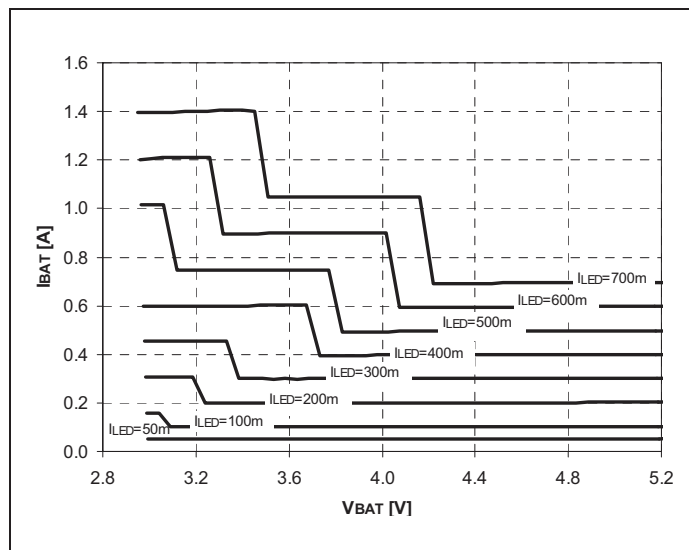
Symbol	Parameter	Min	Typ	Max	Units	Note
$T_{OVTEMP}$	Overtemperature Protection		140		$^{\circ}$ C	If the junction temperature exceeds $T_{OVTEMP}$ , the current sink will be disabled and the charge pump switched back into 1:1 mode until the temperature drops below $T_{OVTEMP} - T_{OVTEMPHYST}$
$T_{OVTEMPHYST}$	Overtemperature Protection Hysteresis		5		$^{\circ}$ C	
$t_{FLASHTIMEOUT}$	Flash Timeout Time	-20%	800	+20%	ms	AS3685A, EN1=1, EN2=1 or AS3685B flash modes

**Typical Operating Characteristics**

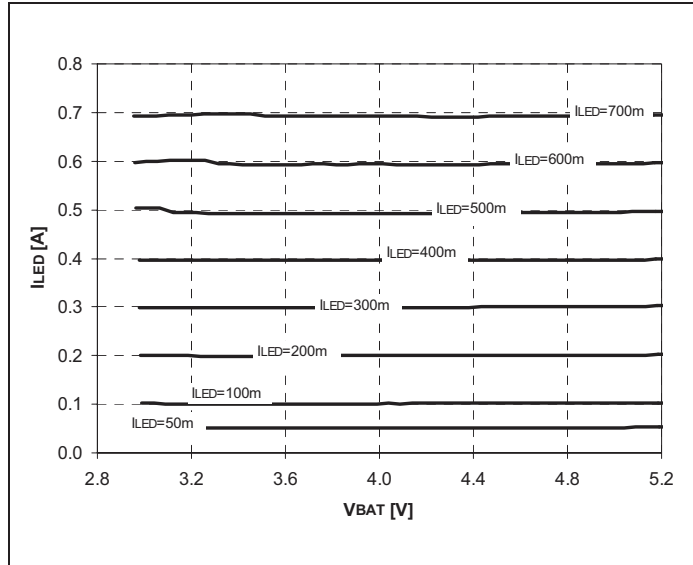
**Figure 13:**  
Efficiency vs. Battery Voltage (with Lumiled PWF1)



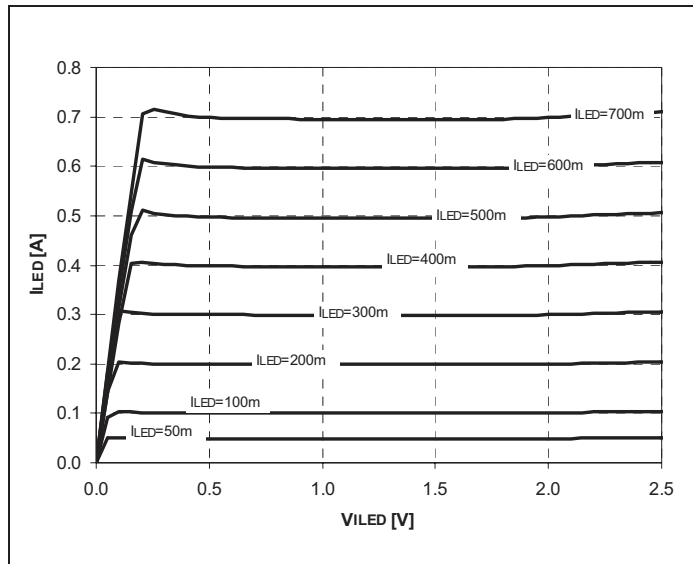
**Figure 14:**  
Battery Current vs. Battery Voltage (with Lumiled PWF1)



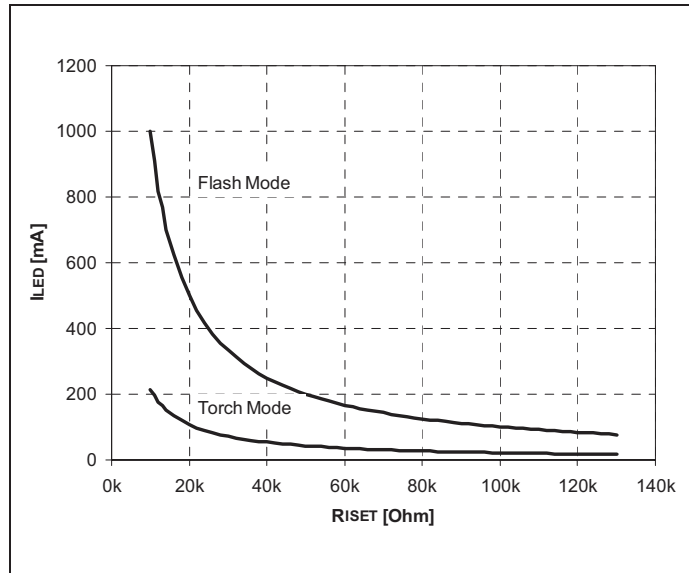
**Figure 15:**  
LED Current I(ILED) vs. Battery Voltage (with Lumiled PWF1)



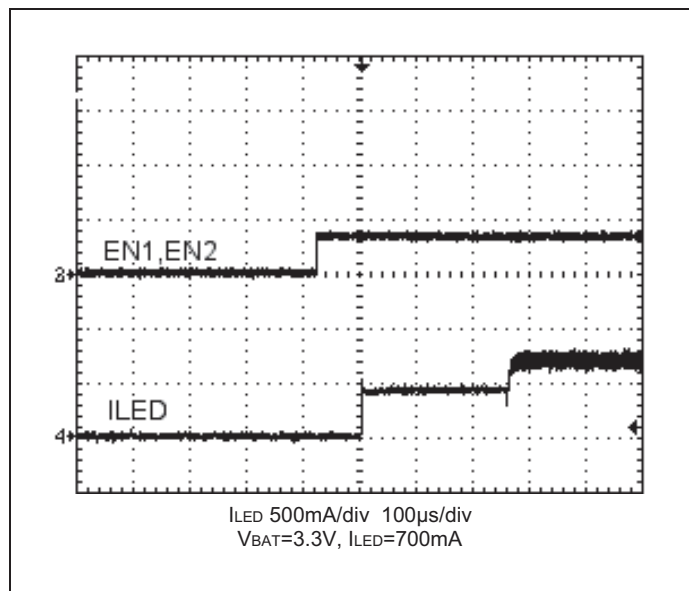
**Figure 16:**  
Linearity of Current Sink



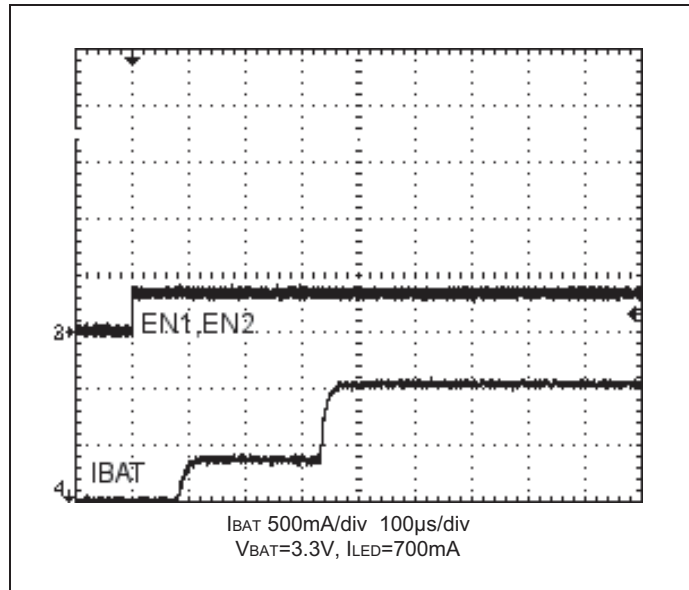
**Figure 17:**  
**I(ILED) vs. R(ISET) (Flash and Torch Mode of AS3685A)**



**Figure 18:**  
**Startup of AS3685A -- I<sub>LED</sub> Current**



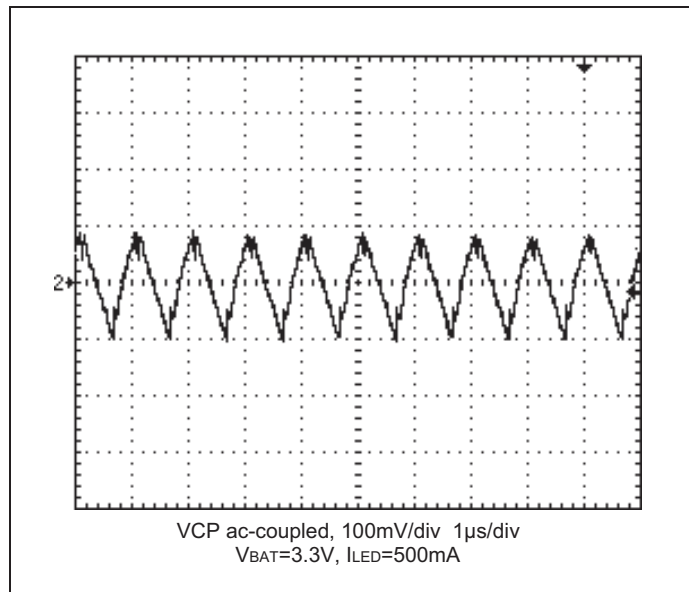
**Figure 19:**  
Startup of AS3685A --  $I_{BAT}$  Current



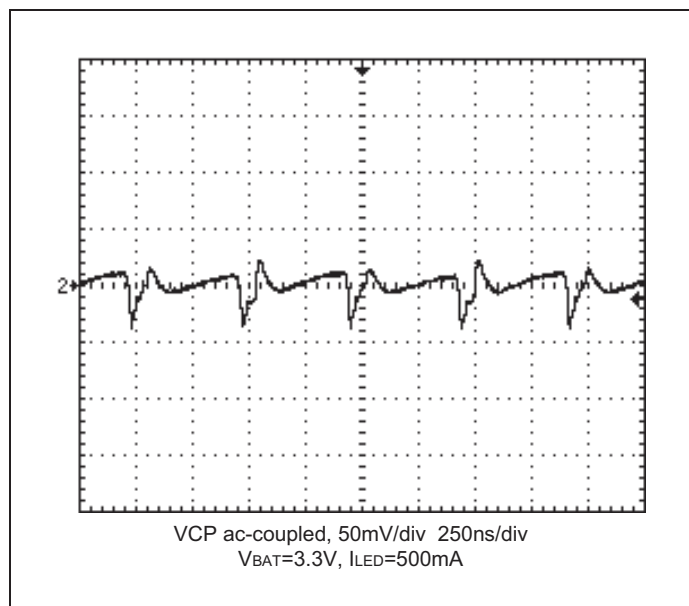
**Figure 20:**  
Shutdown of AS3685A --  $I_{BAT}$  Current



**Figure 21:**  
**Typical Operating Waveforms 1:1.5 Mode**

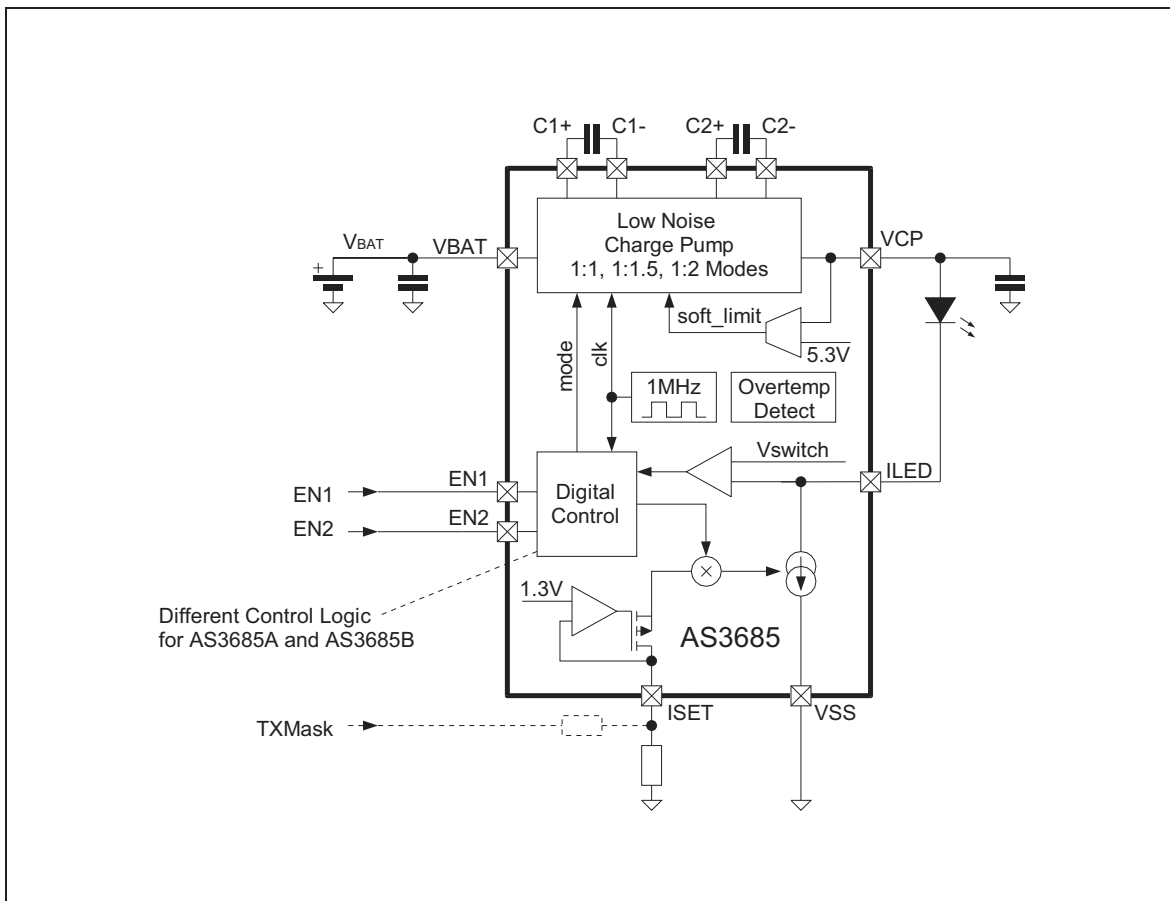


**Figure 22:**  
**Typical Operating Waveforms 1:2 Mode**



## Detailed Description

Figure 23:  
Internal Circuit Diagram of AS3685A/AS3685B



### Low Noise Charge Pump

The AS3685 charge pump uses two external flying capacitors to generate output voltages higher than the battery voltage. The charge pump can operate in three different modes:

- 1:1 Bypass Mode or Off Mode
  - Battery input and output are connected by a low-impedance switch
  - Battery current = output current
- 1:1.5 Mode
  - The output voltage is 1.5 times the battery voltage (without load)
  - Battery current = 1.5 times output current
- 1:2 Mode
  - The output voltage is 2 times the battery voltage (without load)
  - Battery current = 2 times output current

The flying capacitors are switched at the fixed frequency fclk.

### **Mode Switching**

The AS3685 monitors the voltage at the current sink  $V(I_{LED})$  and if this voltage falls below  $V_{SWITCH}$ , for a time longer than the debounce time, the charge pump automatically switches into a higher mode. The debounce time is set to  $t_{UP\_DEB\_LONG}$  at enabling of the charge pump or immediately after a 1:1 to 1:1.5 mode change. Afterwards the debounce time is reduced to  $t_{UP\_DEB}$ . (This allows the LED current to settle properly on startup or after a mode change).

The charge pump enters always 1:1 mode in off mode or in case of overtemperature. It is possible to avoid the 1:2 mode (factory programmable) to limit the battery current to 1.5 times the output (=LED) current.

### **Soft Start**

The soft start mechanism reduces the inrush current. Battery current is smoothed when switching the charge pump on and also at each switching condition. This precaution reduces electromagnetic radiation significantly.

### **Current Source (Sink)**

The AS3685 operates in three different modes:

- Indicator Mode: A small (average) current is used to obtain an indication function with the flash LED (e.g. indication for camera operation).
- Torch Mode: A moderate current of e.g. 150mA allows the use of the flash LED as a torch or video light.
- Flash Mode: A high current of e.g. 700mA (up to 1000mA) is set for a high brightness flash. Only in this mode, the flash timeout timer limits the total flash time.
- Pulsed Indicator Mode (only AS3685A): The control device sends a short sequence to the AS3685A and the AS3685A enables the flash LED for a defined fixed duration (torch current setting). This duration is controlled by the AS3685A and the control device does not need to start an internal timer function.

The current through the LED and the operating mode is controlled by the two digital pins EN1 and EN2. There are two versions of the AS3685 available: AS3685A and AS3685B. The only difference between these versions is the digital interface as shown below:

### AS3685A Current Setting

For the AS3685A, the operating mode and the current through the LED is defined by the following table:

**Figure 24:**  
AS3685A Current Settings

EN1	EN2	Mode	$I_{LED}$ for $R_{ISET} =$		Percent of Full Scale	$I_{LED}/I_{ISET}$
			14.2k $\Omega$	10k $\Omega$		
0	0	Off	0mA	0mA	0%	0 (Off)
1	0	Indicator	4.7mA average (=150mA with 1/32 duty cycle <sup>(1)</sup> )	6.7mA average (=214mA with 1/32 duty cycle <sup>(1)</sup> )	0.67% (=21.4% / 32)	52.2 (= $I_{TORCH2ISET}/32$ )
0	1	Torch	150mA	214mA	21.4%	1639 (= $I_{TORCH2ISET}$ )
1	1	Flash	700mA	1000mA	100%	7650 (= $I_{FLASH2ISET}$ )

**Note(s):**

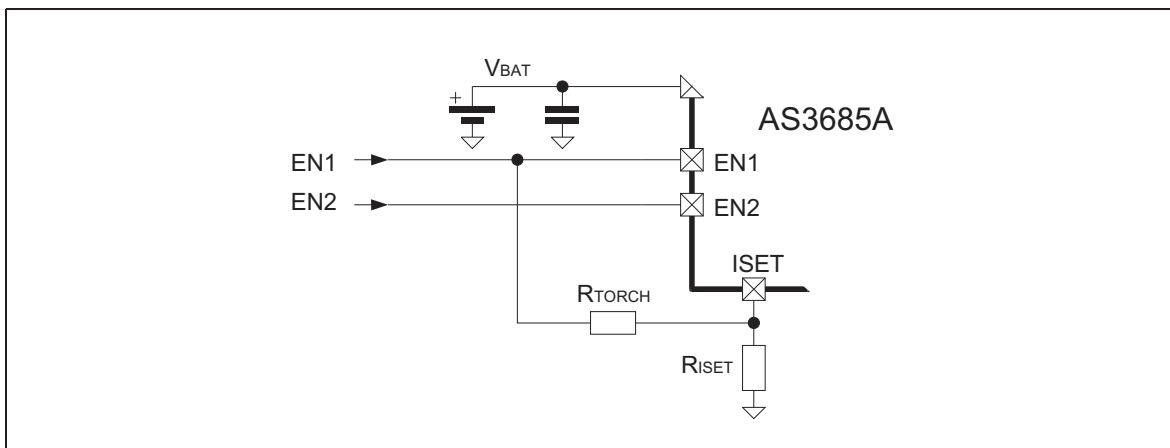
1. The on-time for indicator mode is 1 $\mu$ s, off time 31 $\mu$ s (32 $\mu$ s = 32.25kHz).

Where  $I_{ISET}$  is:

$$(EQ1) \quad I_{ISET} = \frac{V_{ISET}}{R_{ISET}} = \frac{1.3V}{R_{ISET}}$$

**Application Hint:** To obtain higher torch currents use the following circuit:

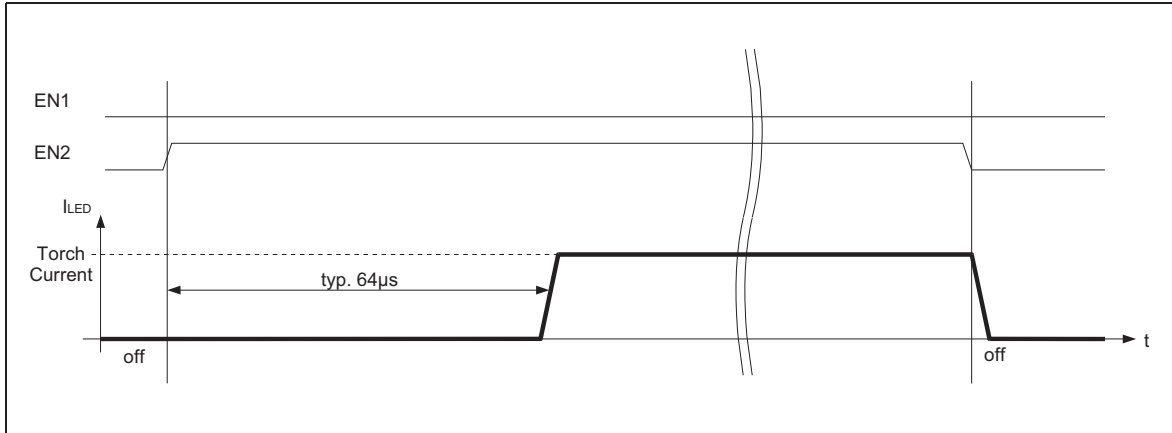
**Figure 25:**  
AS3685A Increasing Torch Current



**AS3685A Pulsed Indicator Mode**

The torch mode is controlled by EN1=0 and EN2=1 as following figure shows:

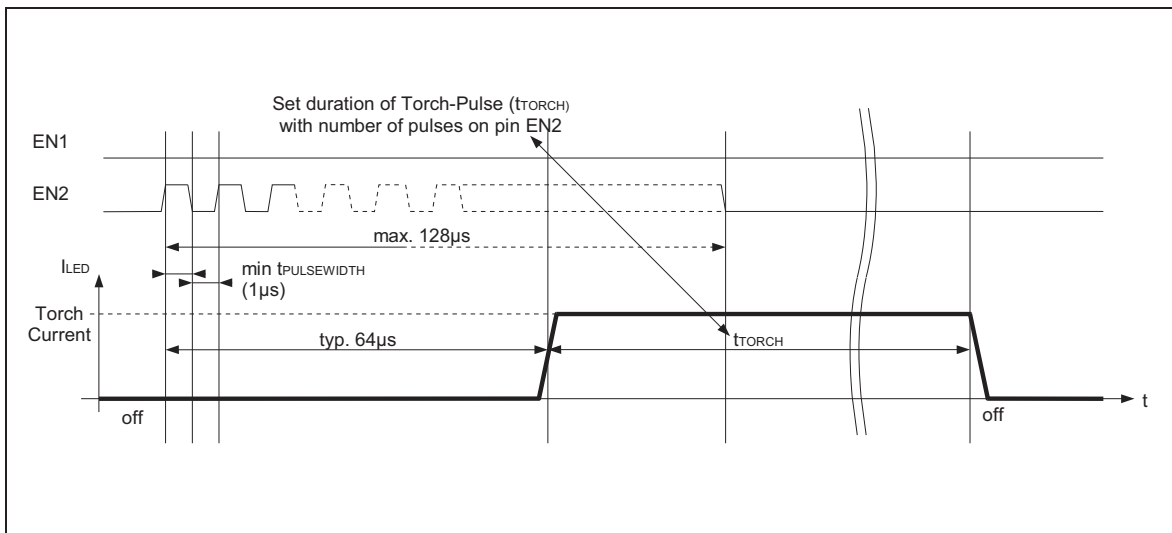
**Figure 26:**  
AS3685A Torch Mode



To allow an indication function using short pulses (with torch current settings), the pulsed indicator mode can be used. The control device sends a setup sequence (total time required: less than 128µs) to 'program' the AS3685A, and the AS3685A enables its current sink for the duration  $t_{TORCH}$  (the current used is exactly the torch current setting). Therefore the control does not need to setup a timer to accurately define the duration of the indicator pulse.

The duration  $t_{TORCH}$  can be setup from 1ms to 15ms depending on the number of pulses on EN2 as shown in the following figure and table:

**Figure 27:**  
AS3685A Pulsed Indicator Mode



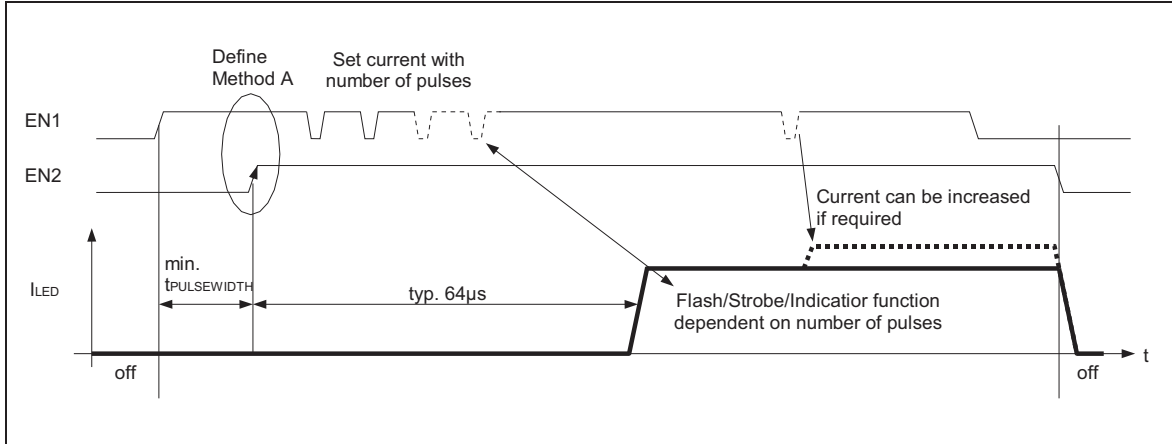
**Figure 28:**  
AS3685A  $t_{TORCH}$  Timings

H-L Pulses on EN2	$t_{TORCH}$
1,2	0ms ignored (noise filter)
3	1ms
4	2ms
5	3ms
6	4ms
7	5ms
8	6ms
9	7ms
10	8ms
11	9ms
12	10ms
13	11ms
14	12ms
15	13ms
16	14ms
$\geq 17$	15ms

**AS3685B Current Setting**

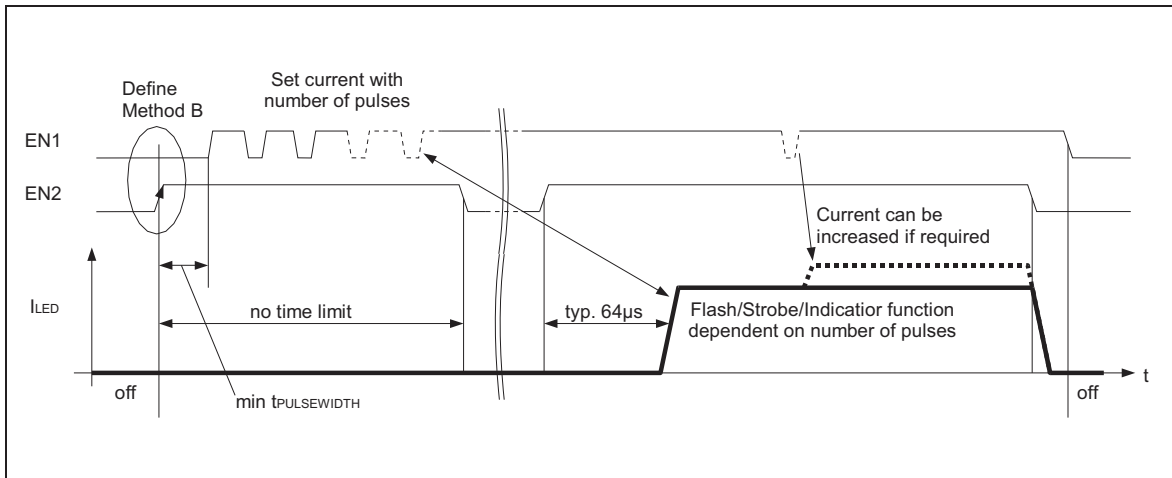
The current through the LED ( $I_{LED}$ ) can be set in several steps using the following waveforms:

**Figure 29:**  
AS3685B Current Setting Method A



For method A, the current is started after a certain time after the first rising edge of EN1. The AS3685B chooses method A, if EN1 is high at the first rising edge of EN2.

**Figure 30:**  
AS3685B Current Setting Method B



For method B, the current is started after the second rising edge of EN2. The AS3685B chooses method B, if EN1 is low at the first rising edge of EN2.

Any high or low level duration for EN1 or EN2 should not be shorter than  $t_{PULSEWIDTH}$ .

The actual number of pulses on the pin EN1 (applies for methods A and B) define the mode and the current settings for the AS3685B:

**Figure 31:**  
**AS3685B Current Settings**

H-L-H Pulses on EN1	Mode	$I_{LED}$ (for $R_{ISET} = 14.2k\Omega$ )	$I_{LED}$ (for $R_{ISET} = 10k\Omega$ )	$I_{LED}/I_{ISET}$
EN1=EN2=0	Off	0mA	0%	0 (Off)
0	Indicator	4.7mA average	6.7mA	52.2
1		(=150mA with 1/32 duty cycle <sup>(1)</sup> )	(=214mA with 1/32 duty cycle <sup>(1)</sup> )	(= $I_{TORCH2ISET}/32$ )
2	Torch	41mA	60mA	448
3		85mA	120mA	929
4		129mA	180mA	1410
5		173mA	250mA	1891
6	Flash	217mA	310mA	2371
7	Flash	261mA	370mA	2852
8		305mA	440mA	3333
9		349mA	500mA	3814
10		393mA	560mA	4295
11		437mA	620mA	4776
12		481mA	690mA	5257
13		525mA	750mA	5737
14		569mA	810mA	6218
15		613mA	880mA	6699
16		657mA	940mA	7180
17		700mA	1000mA	7650(= $I_{FLASH2ISET}$ )

**Note(s):**

1. The on-time for indicator mode is 1 $\mu$ s, off time 31 $\mu$ s (32 $\mu$ s = 32.25kHz).

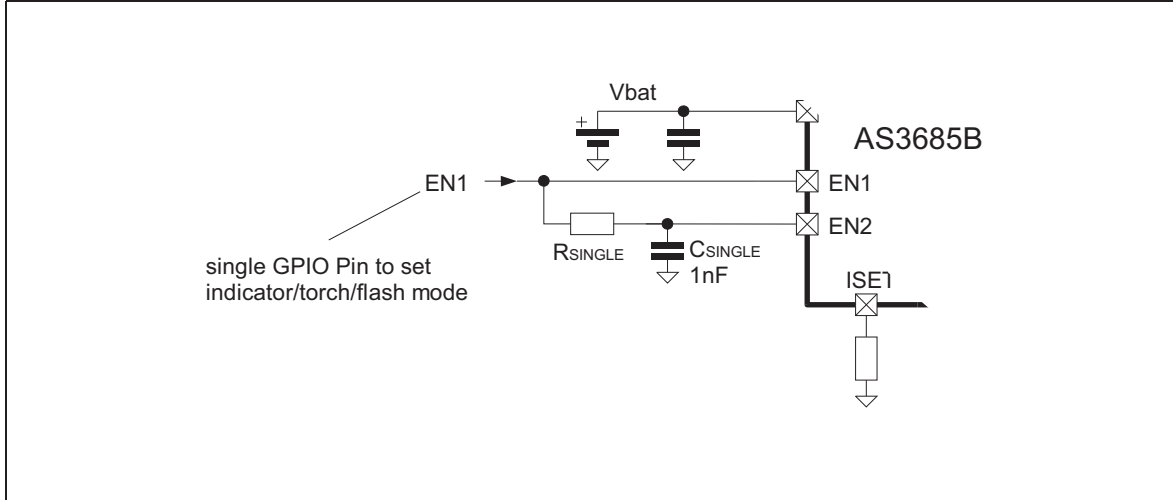
Where  $I_{ISET}$  is:

$$(EQ2) \quad I_{ISET} = \frac{V_{ISET}}{R_{ISET}} = \frac{1.3V}{R_{ISET}}$$

**AS3685B Single Wire Interface**

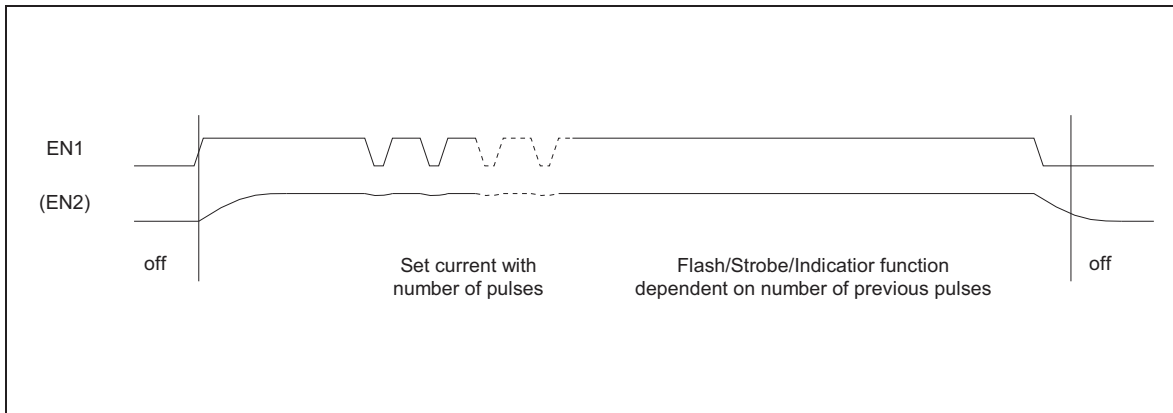
Using the following application schematic, a single GPIO pin can be used to control the mode and current of the AS3685B:

**Figure 32:**  
AS3685B Single Wire Interface



An example driving waveform can be (this uses method A as shown above in section 'AS3685B Current Settings'):

**Figure 33:**  
AS3685B Example Single Wire Interface Driving Waveform

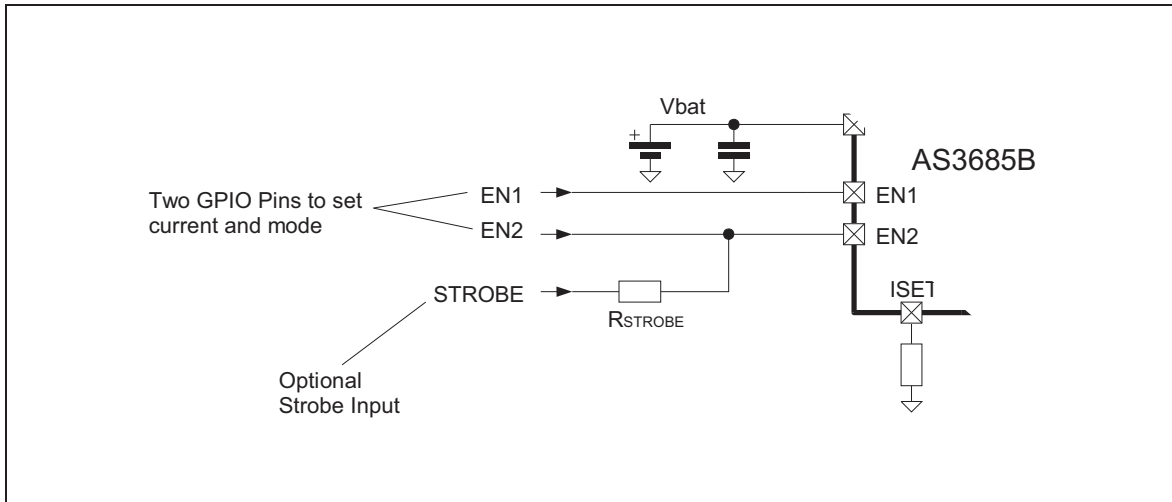


The low time of the pulses on EN1 for setting the current should be kept short. Then the (generated) signal on pin EN2 will stay at a high level during this time ensuring correct operation.  $R_{SINGLE}$  should be chosen to fit to the actual driving waveform on EN1.

**AS3685B Two Wire Interface with Strobe Input**

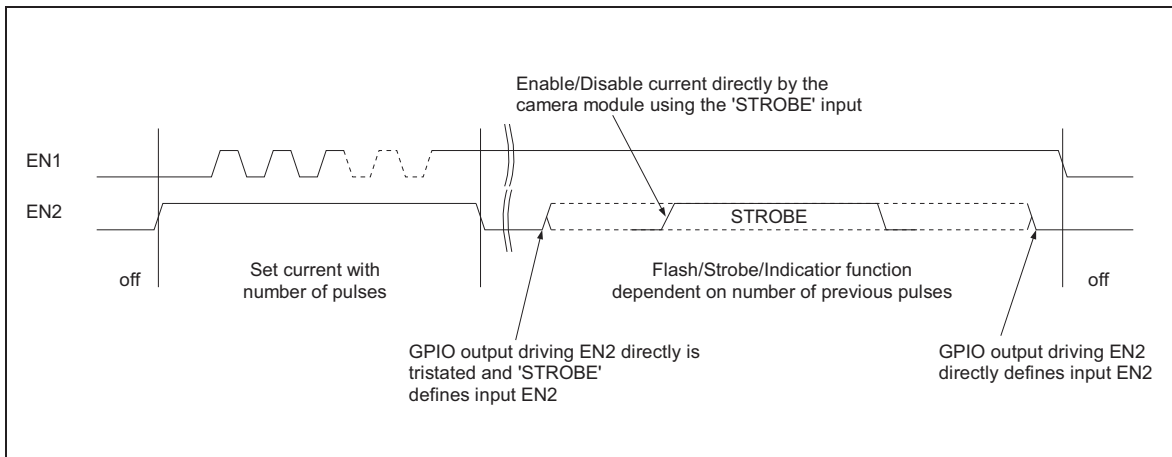
Using the following application schematic, the AS3685B current and mode can be set accurately and the camera can directly control the exact strobe time:

**Figure 34:**  
AS3685B Two Wire Interface with Strobe Input



An example driving waveform can be (this uses method B as shown above in section [AS3685B Current Setting](#)):

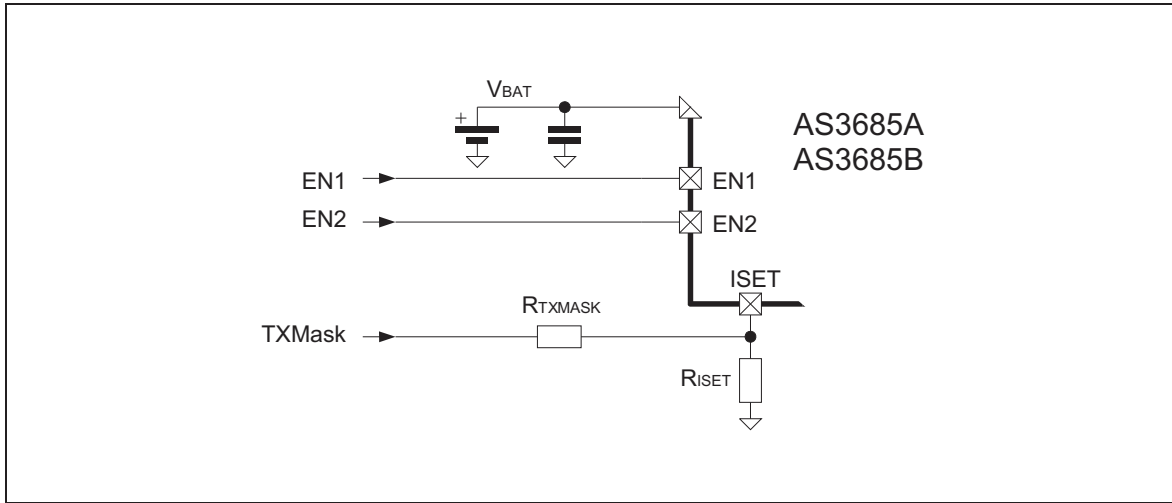
**Figure 35:**  
AS3685B Example Two Wire Interface Driving Waveform



**AS3685A and AS3685B TXMask Function**

If the battery has to supply two high currents at the same time (e.g. the AS3685 flash and a RF-power amplifier) it is possible, that the total current causes a high voltage drop on the battery resulting in a shutdown of the complete system. In order to avoid this shutdown, the AS3685 (AS3685A or AS3685B) can reduce its current with the signal 'TXMask' using the following circuit:

**Figure 36:**  
TXMask Function of the AS3685



The TXMask signal is connected to e.g. the (RF-) power amplifier enable pin (active high if the PA is enabled). This reduces the flash current if the power amplifier is enabled and avoids the unexpected shutdown of the system.

**Note(s):** The internal flash timeout timer ( $t_{FLASH\ TIMEOUT}$ ) to limit the total flash duration, is not affected by the TXMask function (see also section [Flash Timeout](#)).

The  $I_{ISET}$  current (current into the pin ISET) for TXMask = 0 can be calculated with:

$$(EQ3) \quad I_{ISET, TXMASK = 0} = \frac{V_{ISET}}{R_{ISET}} + \frac{V_{ISET}}{R_{TXMASK}} = \frac{1.3V}{R_{ISET}} + \frac{1.3V}{R_{TXMASK}}$$

For TXMask = 1 the current  $I_{ISET}$  is reduced to:

$$(EQ4) \quad I_{ISET, TXMASK = 1} = \frac{V_{ISET}}{R_{ISET}} + \frac{V_{ISET} - V(TXMASK)}{R_{TXMASK}} = \frac{1.3V}{R_{ISET}} + \frac{1.3V - V(TXMASK)}{R_{TXMASK}}$$

$V(TXMask)$  is the actual voltage for the high level ('1') for the signal TXMask

The maximum flash current  $I_{LEDMAX}$  for TXMask=0 or 1 can be calculated according to the following formula using the above obtained  $I_{ISET}$  values:

$$(EQ5) \quad I_{LEDMAX} = I_{FLASH2BIAS} I_{ISET} = 7650 \cdot I_{ISET}$$

Choose the values for  $R_{ISET}$  and  $R_{TXMASK}$  according to your application requirements.

## Protection Functions

### ***Overtemperature Protection***

If the AS3685 junction temperature exceeds  $T_{OVTEMP}$ , the current sink will be disabled and the charge pump forced into 1:1 mode. If the junction temperature drops below  $T_{OVTEMP} - T_{OVTEMPHYST}$ , the device enables the current sink again and the charge pump resumes normal operation.

### ***LED Shortcircuit Protection***

If the LED is shorted (VCP to ILED), then depending on the set current and the resulting high power dissipation inside the AS3685, the overtemperature protection will trigger. This protects the AS3685 and the system against damage. If the AS3685 is in off-mode, then shorting of the diode will have no influence on the system.

**Note(s):** Do not short VCP to VSS if the supply is not current limited (e.g. by an internal protection inside the battery), as there is an internal diode between VBAT (anode) and VCP (cathode).

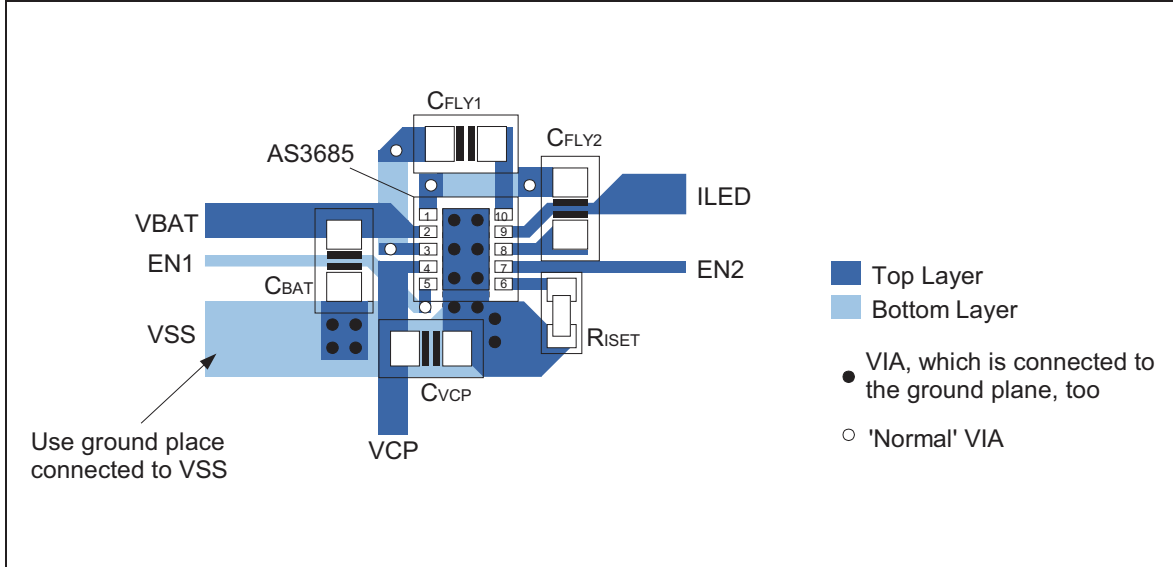
### ***Flash Timeout***

The flash duration of a single flash is limited automatically to  $t_{FLASHTIMEOUT}$  (applies only for 'Flash' mode(s)). This protects the flash LED against thermal damage.

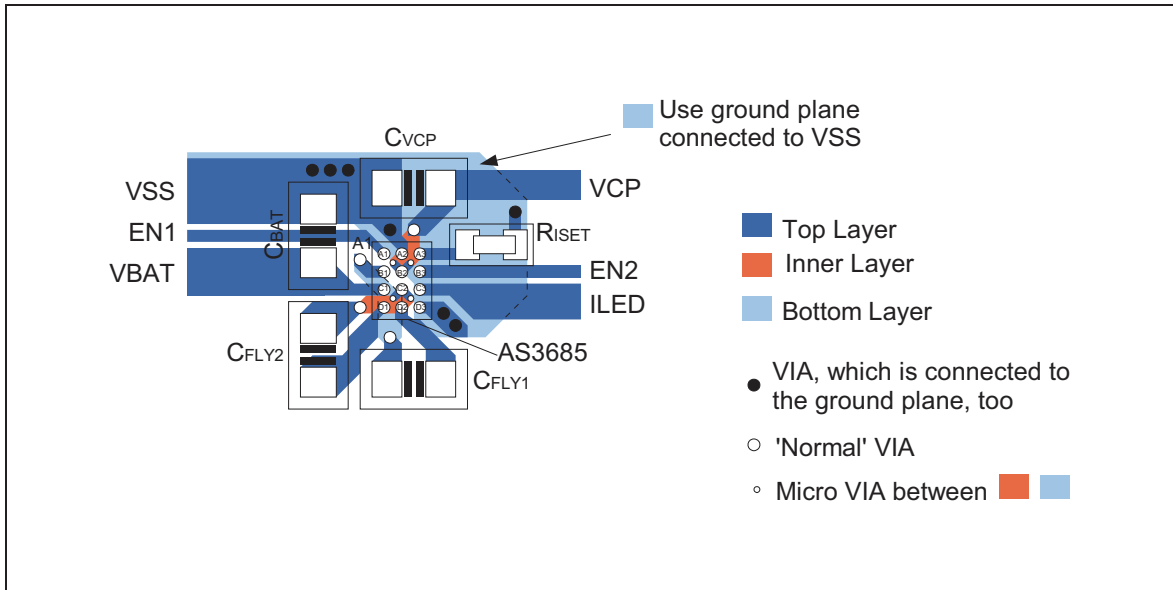
### Layout Recommendations

To improve the heat dissipation, use a massive ground plane.

**Figure 37:**  
AS3685 DFN10 (3x3mm) Layout Recommendation



**Figure 38:**  
AS3685 WL-CSP (2x1.5mm) Layout Recommendation



## External Components

### Capacitor and Resistor Selection

Use low-ESR ceramic capacitors with X7R or X5R dielectric. These capacitors allow good filtering and have a wide temperature range. The connections of all external capacitors should be kept as short as possible. All resistors should have a tolerance of  $\pm 1\%$ .

### Usage of PCB Wire Inductance

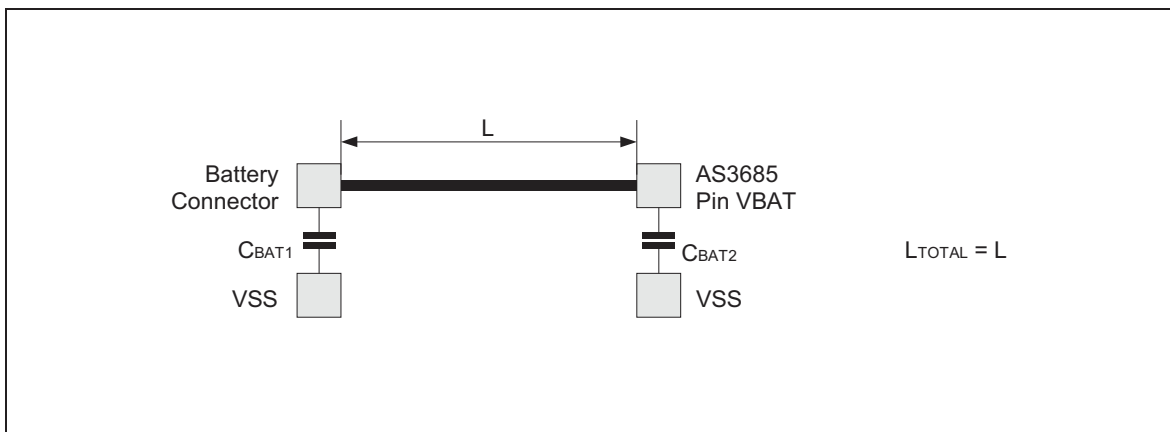
The inductance between the battery and pin VBAT can be used as a filter to reduce disturbance on the battery. Instead of using one capacitor ( $C_{BAT}$ ) it is recommended to split  $C_{BAT}$  into  $C_{BAT1}$  and  $C_{BAT2}$  with the capacitance of

$$(EQ6) \quad C_{BAT1} = C_{BAT2} = C_{BAT}$$

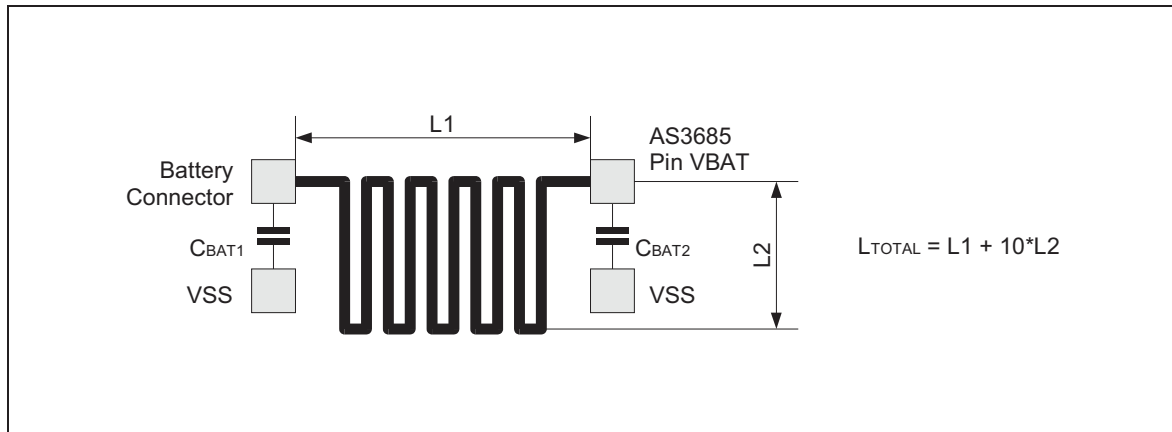
It is recommended to apply a minimum of 20nH (maximum 200nH) with low impedance. This inductance can be realized on the PCB without any discrete coil. Assuming that a 1mm signal line corresponds to approximately 1nH (valid if the length ( $L$ ) is significantly bigger than the width ( $W$ ) of the line ( $L/W < 10$ )), a line length of

$$(EQ7) \quad 20\text{mm} < L < 200\text{mm}$$

**Figure 39:**  
PCB Wire Inductance Example 1



**Figure 40:**  
PCB Wire Inductance Example2



### External Component Specifications

**Figure 41:**  
External Components List

Part	Value			Tol (Min)	Rating (Max)	Notes	Package (Min)
	Min	Typ	Max				
$C_{BAT}^{(1)}$		2.2 $\mu$ f		$\pm 20\%$	6.3V	Ceramic, X5R e.g. Murata GRM21BR71A225KA01L	0603
$C_{FLY1}$ , $C_{FLY2}$		1.0 $\mu$ f		$\pm 20\%$	6.3V	Ceramic, X5R e.g. Murata GRM188R60J105K	0603 (0402,0405)
$C_{VCP}$		2.2 $\mu$ f		$\pm 20\%$	6.3V	Ceramic, X5R e.g. Murata GRM21BR71A225KA01L	0603
$R_{ISET}$	10k $\Omega$		130k $\Omega$	$\pm 1\%$		Current Set Resistor	0201
$R_{TXMASK}$	See section 'TXMask function'			$\pm 1\%$		TXMask Set Resistor	0201
$D_{LED}$	Flash LED						

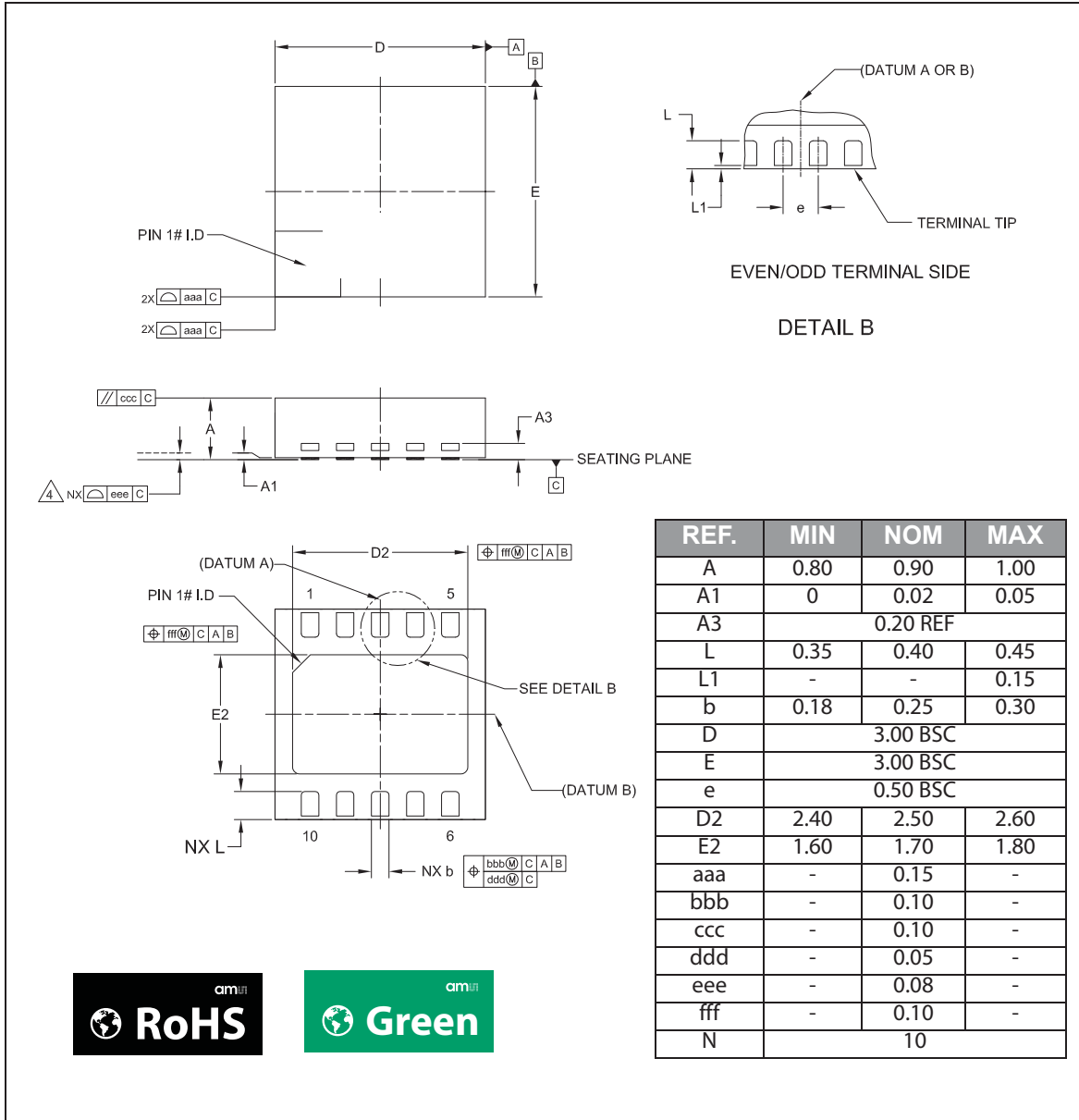
**Note(s):**

1. See section [Usage of PCB Wire Inductance](#).

## Package Drawings & Markings

### DFN10 (3 × 3mm)

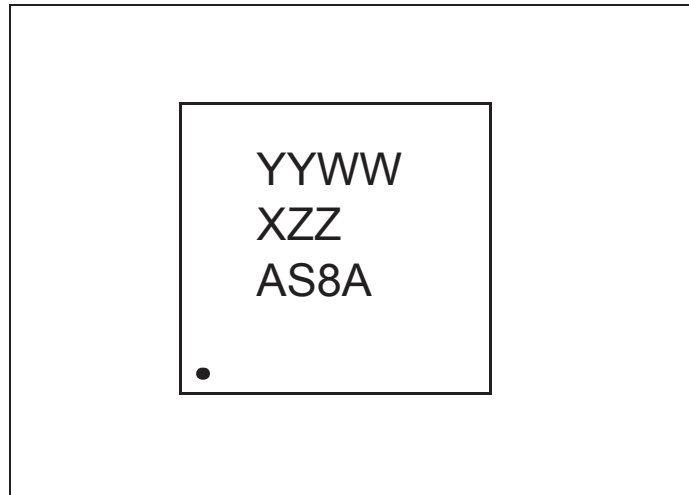
Figure 42:  
DFN10 (3x3mm) Package Drawing



**Note(s):**

1. Dimensioning & tolerancing confirm to ASME Y14.5M-1994
2. All dimensions are in millimeters. Angles are in degrees.
3. Dimension b applies to metallized terminal and is measured between 0.25mm to 0.30mm from terminal tip. dimension L1 represents terminal full back from package edge up to 0.1mm is acceptable.
4. Coplanarity applies to the exposed heat slug as well as the terminal.
5. Radius on the terminal optional.
6. N is the total number of terminals.

**Figure 43:**  
DFN Package Marking



**Note(s):**

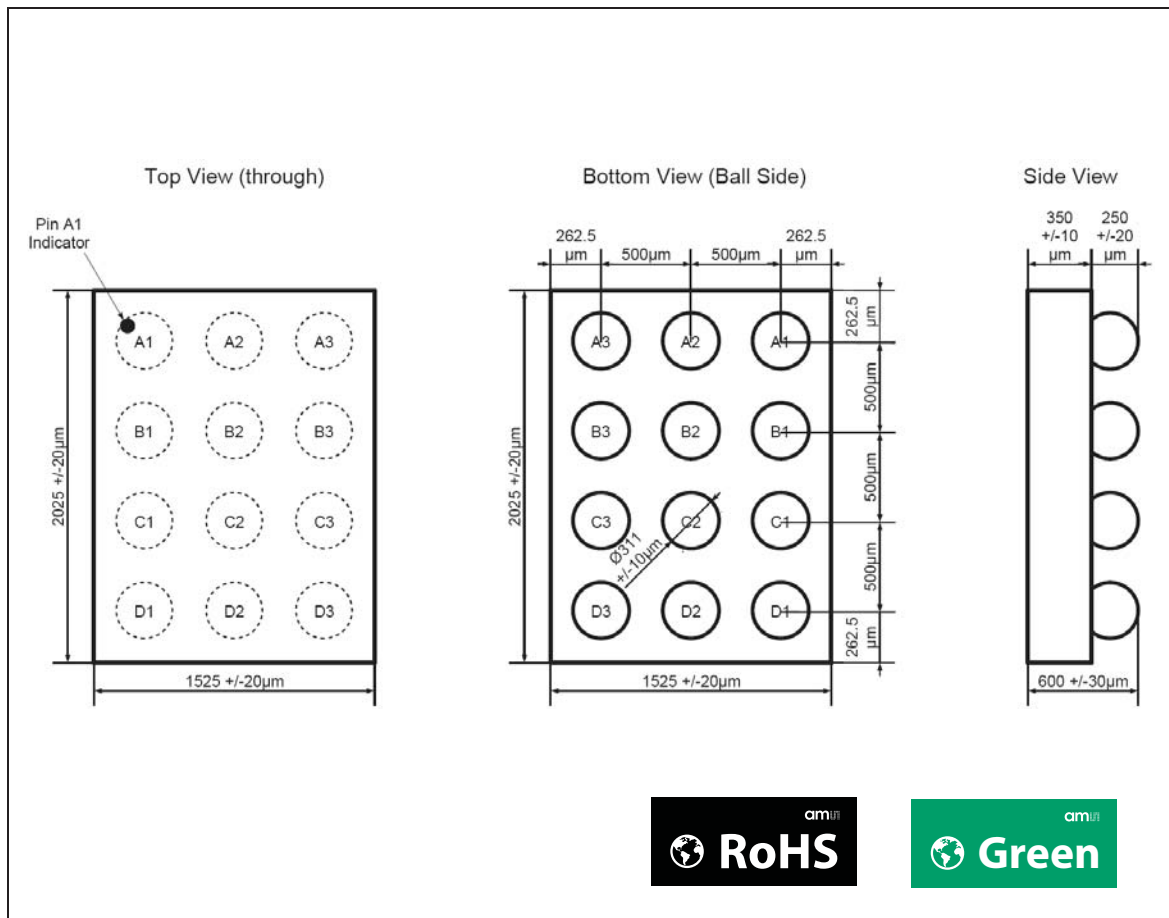
1. AS8A for AS3685A or AS8B for AS3685B.

**Figure 44:**  
DFN Package Code YYWWXZZ

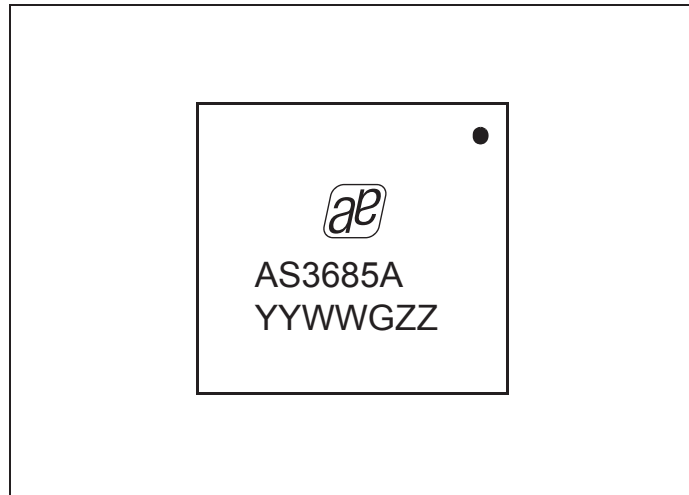
YY	WW	X	ZZ
Last two digits of the manufacturing year	Manufacturing week	Plant identifier	Letters for free choice

### WL-CSP (2 x 1.5mm)

Figure 45:  
WL-CSP (2x1.5mm) Package Drawing



**Figure 46:**  
**WL-CSP Package Marking**



**Figure 47:**  
**WL-CSP Package Code YYWWGZZ**

YY	WW	G	ZZ
Last two digits of the manufacturing year	Manufacturing week	Plant identifier	Letters for free choice

## Ordering & Contact Information

The devices are available as the standard products shown in [Figure 48](#).

**Figure 48:**  
Ordering Information

Ordering Code	Description	Marking	Package	Delivery Form	Delivery Quantity
AS3685A-ZWLT-2N80	AS3685A interface version, 800ms flash timeout, 1:2 mode <b>locked</b>	AS3685A	WL-CSP 2x1.5mm	Tape & Reel	6000 pcs/reel
AS3685A-ZWLT-2Y80	AS3685A interface version, 800ms flash timeout, 1:2 mode <b>enabled</b> <sup>(1)</sup>	AS3685A2	WL-CSP 2x1.5mm	Tape & Reel	6000 pcs/reel
AS3685A-ZDFT-2Y80	AS3685A interface version, 800ms flash timeout, 1:2 mode <b>enabled</b> <sup>(1)</sup>	AS8A	DFN 10 3x3mm	Tape & Reel	6000 pcs/reel
AS3685B-ZDFT-2Y80	AS3685B interface version, 800ms flash timeout, 1:2 mode <b>enabled</b>	AS8B	DFN 10 3x3mm	Tape & Reel	6000 pcs/reel

**Note(s):**

1. If 1000mA flash LED current is used it is usually required to allow 1:2 mode (due to the high forward voltage of the LED).

**Description:**

AS3685V-ZPPT-2X80

V ... AS3685 Interface Version:  
 A = AS3685A: Direct control to select three different currents.  
 B = AS3685B: Single or two pin interface with strobe; 17 different current settings.  
 -  
 Z ... Temperature Range: Z = -30°C to 85°C  
 PP ... Package: WL = Wafer Level Chip Scale Package  
 DF = DFN10  
 T ... Delivery Form: T = Tape & Reel  
 -  
 2X ... Charge Pump Mode Locking:  
 2N = 1:2 mode locked (device can only use 1:1 and 1:1.5 mode)  
 2Y = 1:2 mode available (device can use 1:1, 1:1.5 and 1:2 mode)  
 80 ... Flash Timeout Time Programming  
 80 = 800ms flash timeout time

Buy our products or get free samples online at:

[www.ams.com/ICdirect](http://www.ams.com/ICdirect)

Technical Support is available at:

[www.ams.com/Technical-Support](http://www.ams.com/Technical-Support)

Provide feedback about this document at:

[www.ams.com/Document-Feedback](http://www.ams.com/Document-Feedback)

For further information and requests, e-mail us at:

[ams\\_sales@ams.com](mailto:ams_sales@ams.com)

For sales offices, distributors and representatives, please visit:

[www.ams.com/contact](http://www.ams.com/contact)

#### **Headquarters**

ams AG

Tobelbaderstrasse 30

8141 Premstaetten

Austria, Europe

Tel: +43 (0) 3136 500 0

Website: [www.ams.com](http://www.ams.com)

## RoHS Compliant & ams Green Statement

**RoHS:** The term RoHS compliant means that ams AG products fully comply with current RoHS directives. Our semiconductor products do not contain any chemicals for all 6 substance categories, including the requirement that lead not exceed 0.1% by weight in homogeneous materials. Where designed to be soldered at high temperatures, RoHS compliant products are suitable for use in specified lead-free processes.

**ams Green (RoHS compliant and no Sb/Br):** ams Green defines that in addition to RoHS compliance, our products are free of Bromine (Br) and Antimony (Sb) based flame retardants (Br or Sb do not exceed 0.1% by weight in homogeneous material).

**Important Information:** The information provided in this statement represents ams AG knowledge and belief as of the date that it is provided. ams AG bases its knowledge and belief on information provided by third parties, and makes no representation or warranty as to the accuracy of such information. Efforts are underway to better integrate information from third parties. ams AG has taken and continues to take reasonable steps to provide representative and accurate information but may not have conducted destructive testing or chemical analysis on incoming materials and chemicals. ams AG and ams AG suppliers consider certain information to be proprietary, and thus CAS numbers and other limited information may not be available for release.

## Copyrights & Disclaimer

Copyright ams AG, Tobelbader Strasse 30, 8141 Premstaetten, Austria-Europe. Trademarks Registered. All rights reserved. The material herein may not be reproduced, adapted, merged, translated, stored, or used without the prior written consent of the copyright owner.

Devices sold by ams AG are covered by the warranty and patent indemnification provisions appearing in its General Terms of Trade. ams AG makes no warranty, express, statutory, implied, or by description regarding the information set forth herein. ams AG reserves the right to change specifications and prices at any time and without notice. Therefore, prior to designing this product into a system, it is necessary to check with ams AG for current information. This product is intended for use in commercial applications. Applications requiring extended temperature range, unusual environmental requirements, or high reliability applications, such as military, medical life-support or life-sustaining equipment are specifically not recommended without additional processing by ams AG for each application. This product is provided by ams AG "AS IS" and any express or implied warranties, including, but not limited to the implied warranties of merchantability and fitness for a particular purpose are disclaimed.

ams AG shall not be liable to recipient or any third party for any damages, including but not limited to personal injury, property damage, loss of profits, loss of use, interruption of business or indirect, special, incidental or consequential damages, of any kind, in connection with or arising out of the furnishing, performance or use of the technical data herein. No obligation or liability to recipient or any third party shall arise or flow out of ams AG rendering of technical or other services.

## Document Status

Document Status	Product Status	Definition
Product Preview	Pre-Development	Information in this datasheet is based on product ideas in the planning phase of development. All specifications are design goals without any warranty and are subject to change without notice
Preliminary Datasheet	Pre-Production	Information in this datasheet is based on products in the design, validation or qualification phase of development. The performance and parameters shown in this document are preliminary without any warranty and are subject to change without notice
Datasheet	Production	Information in this datasheet is based on products in ramp-up to full production or full production which conform to specifications in accordance with the terms of ams AG standard warranty as given in the General Terms of Trade
Datasheet (discontinued)	Discontinued	Information in this datasheet is based on products which conform to specifications in accordance with the terms of ams AG standard warranty as given in the General Terms of Trade, but these products have been superseded and should not be used for new designs

## Revision Information

Changes from 2.20 to current revision 2-23 (2016-Mar-30)	Page
<b>2.20 to 2-21 (2016-Mar-08)</b>	
Content of austriamicrosystems datasheet was updated to latest <b>ams</b> design	
Updated product name	1
Added benefits to Figure 1	1
Updated Package Drawings & Markings section	29
<b>2-21 (2016-Mar-08) to 2-22 (2016-Mar-23)</b>	
Updated Figure 7	6
Updated Figure 42	29
Updated Figure 46	32
<b>2-22 (2016-Mar-23) to 2-23 (2016-Mar-30)</b>	
Updated Figure 7	6

**Note(s):**

1. Page and figure numbers for the previous version may differ from page and figure numbers in the current revision.
2. Correction of typographical errors is not explicitly mentioned.

## Content Guide

<b>1</b>	<b>General Description</b>
1	Key Benefits & Features
2	Applications
<b>3</b>	<b>Pin Assignment</b>
3	DFN10 (3x3mm)
4	WL-CSP (2x1.5mm)
<b>6</b>	<b>Absolute Maximum Ratings</b>
<b>7</b>	<b>Electrical Characteristics</b>
<b>10</b>	<b>Typical Operating Characteristics</b>
<b>15</b>	<b>Detailed Description</b>
15	Low Noise Charge Pump
16	Mode Switching
16	Soft Start
16	Current Source (Sink)
17	AS3685A Current Setting
20	AS3685B Current Setting
24	AS3685A and AS3685B TXMask Function
25	Protection Functions
25	Overtemperature Protection
25	Flash Timeout
26	Layout Recommendations
<b>27</b>	<b>External Components</b>
27	Capacitor and Resistor Selection
27	Usage of PCB Wire Inductance
28	External Component Specifications
<b>29</b>	<b>Package Drawings &amp; Markings</b>
29	DFN10 (3 × 3mm)
31	WL-CSP (2 x 1.5mm)
<b>33</b>	<b>Ordering &amp; Contact Information</b>
<b>35</b>	<b>RoHS Compliant &amp; ams Green Statement</b>
<b>36</b>	<b>Copyrights &amp; Disclaimer</b>
<b>37</b>	<b>Document Status</b>
<b>38</b>	<b>Revision Information</b>

## Looking for pricing, stock, or lifecycle information?

Click below to explore more details on WIN SOURCE:

 [View AS3685A-DB-DFN on WIN SOURCE](#)

 [ams Information](#)

## Optimize Your Supply Chain with WIN SOURCE Solutions

-  Global Sourcing Solution
-  Obsolete Management
-  Cost Control Management
-  Shortage Management
-  Alternative Solution
-  Excess Inventory Management