



THE DATASHEET OF SHOW-BOARD I



Multi-Product

Show Board Application Note

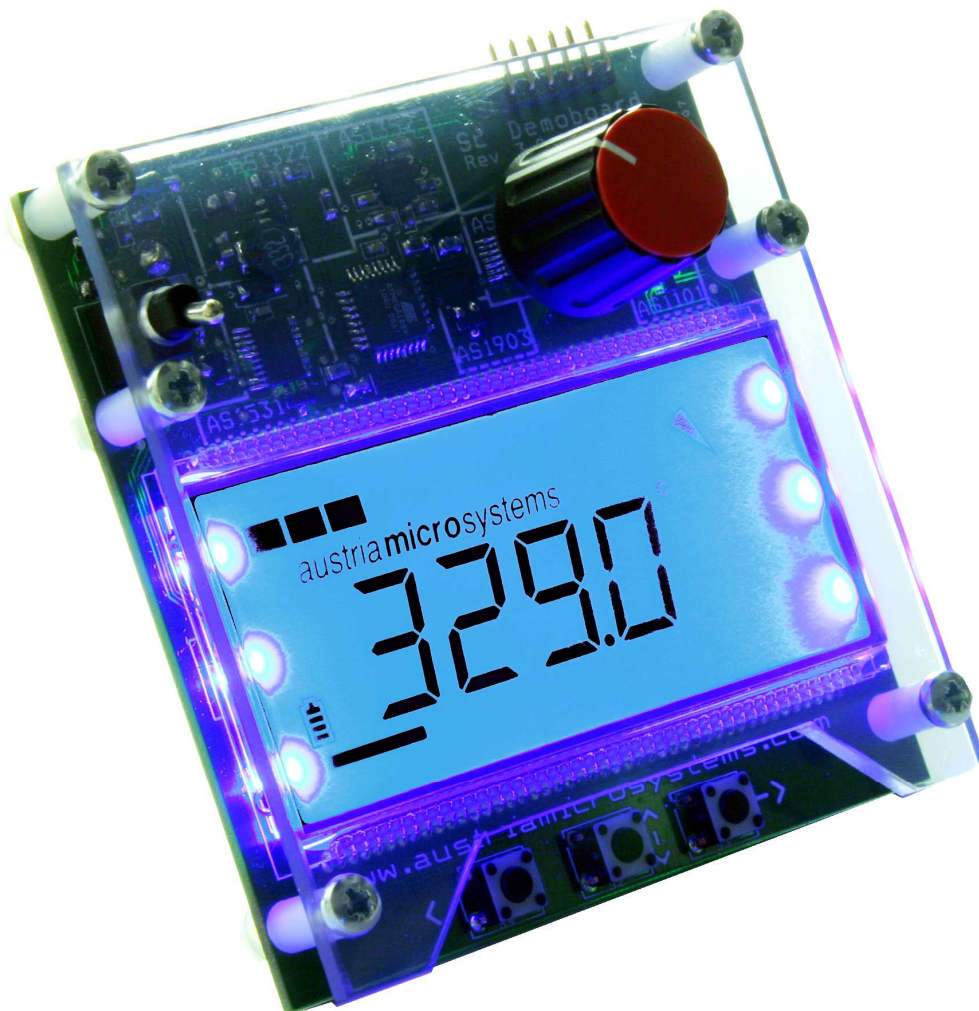

General Description

Board Description

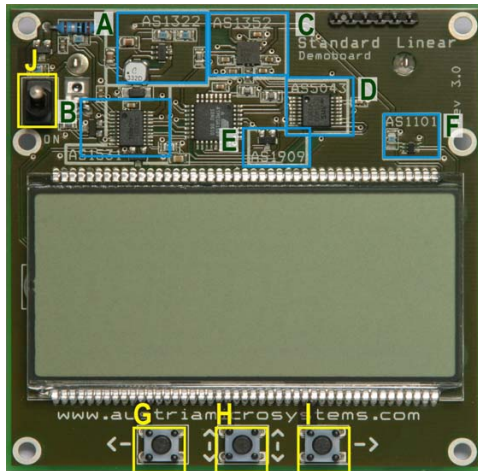

Figure 1: Board Description Front

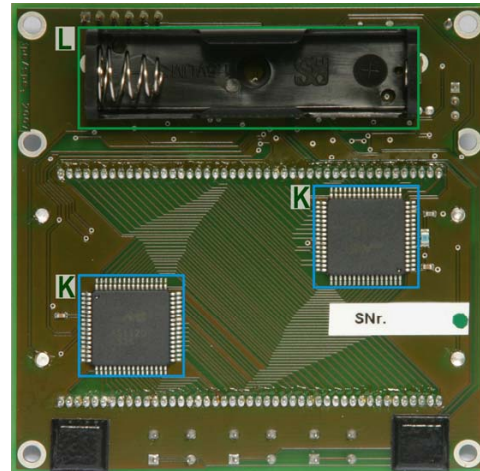

Figure 2: Board Description Back

austriamicrosystems Parts Description

Label	Name	Description	Info
A	AS1322	DC-DC Step-Up Converter	Click here for Datasheet / Product Info
B	AS1531	12-Bit, 8-Channel 300ksps ADC	Click here for Datasheet / Product Info
C	AS1352	Programmable Quad LDO	Click here for Datasheet / Product Info
D	AS5043	Rotary Encoder	Click here for Datasheet / Product Info
E	AS1909	Supervisor	Click here for Datasheet / Product Info
F	AS1101	Low Dropout LED Driver	Click here for Datasheet / Product Info
K	AS1120	LCD Driver	Click here for Datasheet / Product Info

Menu Button Description

Label	Name	Description	Info
G	<-	Cycle menu	Rotary Encoder <-> Battery Current <-> Temperature <-> Battery Voltage <-> Backlighting
I	->		
H	^ v	Backlight	Use this Button to increase or decrease the backlighting. Press and hold will in/decrease the light. Button press swaps between decrease increase backlight intensity.

Others

Label	Name	Description	Info
J		On/Off Switch	
L		Battery	

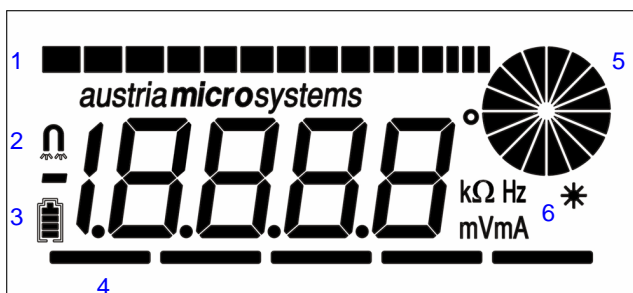

Figure 3: Display

Label	Name
1	Ambient Light Level
2	Blinks if Magnet removed
3	Battery Level
4	Menu Bars
5	Rotary Direction
6	Units

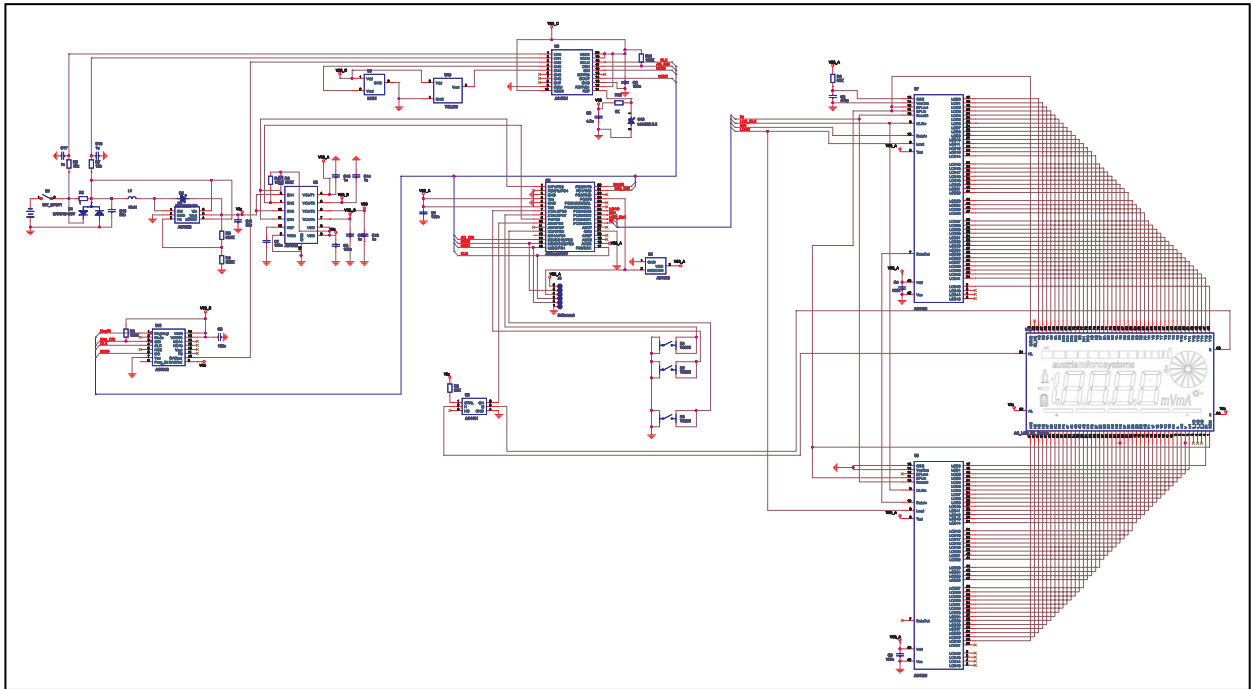

Figure 4: Schematic

Operational sequence

1. Place a single AA Battery in the battery holder.
2. Turn on the Show-Board via the ON/OFF switch.
3. See Menu Button Description for the use of the menu.

If there are questions do not hesitate to contact us. See contact information at the end of the application note.

Copyright

Copyright © 1997-2007, austriamicrosystems AG, Schloss Premstaetten, 8141 Unterpremstaetten, Austria-Europe. Trademarks Registered ®. All rights reserved. The material herein may not be reproduced, adapted, merged, translated, stored, or used without the prior written consent of the copyright owner.

All products and companies mentioned are trademarks or registered trademarks of their respective companies.

Disclaimer

Devices sold by austriamicrosystems AG are covered by the warranty and patent indemnification provisions appearing in its Term of Sale. austriamicrosystems AG makes no warranty, express, statutory, implied, or by description regarding the information set forth herein or regarding the freedom of the described devices from patent infringement. Austriamicrosystems AG reserves the right to change specifications and prices at any time and without notice. Therefore, prior to designing this product into a system, it is necessary to check with austriamicrosystems AG for current information.

This product is intended for use in normal commercial applications. Applications requiring extended temperature range, unusual environmental requirements, or high reliability applications, such as military, medical life-support or lifesustaining equipment are specifically not recommended without additional processing by austriamicrosystems AG for each application. For shipments of less than 100 parts the manufacturing flow might show deviations from the standard production flow, such as test flow or test location.

The information furnished here by austriamicrosystems AG is believed to be correct and accurate. However, austriamicrosystems AG shall not be liable to recipient or any third party for any damages, including but not limited to personal injury, property damage, loss of profits, loss of use, interruption of business or indirect, special, incidental or consequential damages, of any kind, in connection with or arising out of the furnishing, performance or use of the technical data herein. No obligation or liability to recipient or any third party shall arise or flow out of austriamicrosystems AG rendering of technical or other services.



Contact Information

Headquarters

austriamicrosystems AG
A-8141 Schloss Premstätten, Austria
T. +43 (0) 3136 500 0
F. +43 (0) 3136 5692

For Sales Offices, Distributors and Representatives, please visit:
<http://www.austriamicrosystems.com/contact>

Looking for pricing, stock, or lifecycle information?

Click below to explore more details on WIN SOURCE:

- ⊖ View [SHOW-BOARD I](#) on WIN SOURCE
- ⊖ [ams](#) Information

Optimize Your Supply Chain with WIN SOURCE Solutions

- ✓ Global Sourcing Solution
- ✓ Obsolete Management
- ✓ Cost Control Management
- ✓ Shortage Management
- ✓ Alternative Solution
- ✓ Excess Inventory Management