



AR1100 Resistive USB and RS-232
Touch Screen Controller
Data Sheet

Note the following details of the code protection feature on Microchip devices:

- Microchip products meet the specification contained in their particular Microchip Data Sheet.
- Microchip believes that its family of products is one of the most secure families of its kind on the market today, when used in the intended manner and under normal conditions.
- There are dishonest and possibly illegal methods used to breach the code protection feature. All of these methods, to our knowledge, require using the Microchip products in a manner outside the operating specifications contained in Microchip's Data Sheets. Most likely, the person doing so is engaged in theft of intellectual property.
- Microchip is willing to work with the customer who is concerned about the integrity of their code.
- Neither Microchip nor any other semiconductor manufacturer can guarantee the security of their code. Code protection does not mean that we are guaranteeing the product as "unbreakable."

Code protection is constantly evolving. We at Microchip are committed to continuously improving the code protection features of our products. Attempts to break Microchip's code protection feature may be a violation of the Digital Millennium Copyright Act. If such acts allow unauthorized access to your software or other copyrighted work, you may have a right to sue for relief under that Act.

Information contained in this publication regarding device applications and the like is provided only for your convenience and may be superseded by updates. It is your responsibility to ensure that your application meets with your specifications. MICROCHIP MAKES NO REPRESENTATIONS OR WARRANTIES OF ANY KIND WHETHER EXPRESS OR IMPLIED, WRITTEN OR ORAL, STATUTORY OR OTHERWISE, RELATED TO THE INFORMATION, INCLUDING BUT NOT LIMITED TO ITS CONDITION, QUALITY, PERFORMANCE, MERCHANTABILITY OR FITNESS FOR PURPOSE. Microchip disclaims all liability arising from this information and its use. Use of Microchip devices in life support and/or safety applications is entirely at the buyer's risk, and the buyer agrees to defend, indemnify and hold harmless Microchip from any and all damages, claims, suits, or expenses resulting from such use. No licenses are conveyed, implicitly or otherwise, under any Microchip intellectual property rights.

Trademarks

The Microchip name and logo, the Microchip logo, dsPIC, KEELOQ, KEELOQ logo, MPLAB, PIC, PICmicro, PICSTART, PIC³² logo, rPIC and UNI/O are registered trademarks of Microchip Technology Incorporated in the U.S.A. and other countries.

FilterLab, Hampshire, HI-TECH C, Linear Active Thermistor, MXDEV, MXLAB, SEEVAL and The Embedded Control Solutions Company are registered trademarks of Microchip Technology Incorporated in the U.S.A.

Analog-for-the-Digital Age, Application Maestro, chipKIT, chipKIT logo, CodeGuard, dsPICDEM, dsPICDEM.net, dsPICworks, dsSPEAK, ECAN, ECONOMONITOR, FanSense, HI-TIDE, In-Circuit Serial Programming, ICSP, Mindi, MiWi, MPASM, MPLAB Certified logo, MPLIB, MPLINK, mTouch, Omniscient Code Generation, PICC, PICC-18, PICDEM, PICDEM.net, PICkit, PICtail, REAL ICE, rLAB, Select Mode, Total Endurance, TSHARC, UniWinDriver, WiperLock and ZENA are trademarks of Microchip Technology Incorporated in the U.S.A. and other countries.

SQTP is a service mark of Microchip Technology Incorporated in the U.S.A.

All other trademarks mentioned herein are property of their respective companies.

© 2011, Microchip Technology Incorporated, Printed in the U.S.A., All Rights Reserved.

 Printed on recycled paper.

ISBN: 978-1-61341-833-8

QUALITY MANAGEMENT SYSTEM
CERTIFIED BY DNV
== ISO/TS 16949:2009 ==

Microchip received ISO/TS-16949:2009 certification for its worldwide headquarters, design and wafer fabrication facilities in Chandler and Tempe, Arizona; Gresham, Oregon and design centers in California and India. The Company's quality system processes and procedures are for its PIC[®] MCUs and dsPIC[®] DSCs, KEELOQ[®] code hopping devices, Serial EEPROMs, microperipherals, nonvolatile memory and analog products. In addition, Microchip's quality system for the design and manufacture of development systems is ISO 9001:2000 certified.



AR1100 RESISTIVE USB AND RS-232 TOUCH SCREEN CONTROLLER

AR1100 Resistive USB and RS-232 Touch Screen Controller

Special Features:

- RoHS Compliant
- Power-saving Sleep mode
- Industrial Temperature Range
- Built-in Drift Compensation Algorithm
- 96 Bytes of User EEPROM

Power Requirements:

- Operating Voltage: 3.3-5.0V +/- 5%
- Standby Current:
 - <10 uA (UART)
 - <325 uA (USB)
- Operating Current:
 - <17 mA (no touch)
 - <25 mA (touch) (see **Note** below)

Note: Results vary slightly with sensor.

Touch Modes:

- Off, Stream, Down and Up

Touch Sensor Support:

- 4-wire, 5-wire and 8-wire Analog Resistive
- Lead-to-Lead Resistance: 50-2000 Ohm
- Layer-to-Layer Capacitance: 0-0.5 uF

Touch Resolution:

- 10-bit Resolution (maximum)

Touch Coordinate Report Rate:

- 150 Reports Per Second (typ.) (see **Note** below)

Note: Actual report rate is dynamically/automatically maximized according to the electrical characteristics of the sensor in use.

Communication:

- Automatic Detection/Selection
- UART, 9600 BAUD
- USB V2.0 Compliant, Full Speed
 - HID-GENERIC
 - HID-MOUSE
 - HID-DIGITIZER

Package Types

The device will be offered in the following packages:

- 20-Lead QFN (5 x 5 mm)
- 20-Lead SOIC
- 20-Lead SSOP

AR1100 RESISTIVE USB AND RS-232 TOUCH SCREEN CONTROLLER

Table of Contents

1.0	Device Overview	5
2.0	Implementation – Quick Start	7
3.0	Hardware	9
4.0	Communication)	13
5.0	Commands	21
6.0	Configuration Registers	25
7.0	Operation	29
8.0	Boot Loader	33
9.0	EEPROM Map	37
10.0	Electrical Specifications	39
11.0	Packaging Information	41
	Appendix A: Revision History	51
	Appendix B: Device Differences	51
	Index	53
	The Microchip Web Site	55
	Customer Change Notification Service	55
	Customer Support	55
	Reader Response	55
	Product Identification System	57

TO OUR VALUED CUSTOMERS

It is our intention to provide our valued customers with the best documentation possible to ensure successful use of your Microchip products. To this end, we will continue to improve our publications to better suit your needs. Our publications will be refined and enhanced as new volumes and updates are introduced.

If you have any questions or comments regarding this publication, please contact the Marketing Communications Department via E-mail at docerrors@microchip.com or fax the **Reader Response Form** in the back of this data sheet to (480) 792-4150. We welcome your feedback.

Most Current Data Sheet

To obtain the most up-to-date version of this data sheet, please register at our Worldwide Web site at:

<http://www.microchip.com>

You can determine the version of a data sheet by examining its literature number found on the bottom outside corner of any page. The last character of the literature number is the version number, (e.g., DS30000A is version A of document DS30000).

Errata

An errata sheet, describing minor operational differences from the data sheet and recommended workarounds, may exist for current devices. As device/documentation issues become known to us, we will publish an errata sheet. The errata will specify the revision of silicon and revision of document to which it applies.

To determine if an errata sheet exists for a particular device, please check with one of the following:

- Microchip's Worldwide Web site; <http://www.microchip.com>
- Your local Microchip sales office (see last page)

When contacting a sales office, please specify which device, revision of silicon and data sheet (include literature number) you are using.

Customer Notification System

Register on our web site at www.microchip.com to receive the most current information on all of our products.

AR1100 RESISTIVE USB AND RS-232 TOUCH SCREEN CONTROLLER

1.0 OVERVIEW

The Microchip mTouch™ AR1100 Analog Resistive USB and RS-232 Touch Screen Controller represents a feature-rich, fully-integrated universal touch screen controller solution. The AR1100 automatically selects between USB and RS-232 communication protocols, as well as supports 4, 5 or 8-wire analog resistive touch screens from any of a variety of touch screen manufacturers. The AR1100 dynamically adapts to the various touch screen electrical characteristics such as sensitivity, contact resistance, and capacitance to provide optimal performance with minimal design time.

Building on the AR1000 series, the new AR1100 offers customers an easy-to-integrate solution for low-cost, high-performing resistive touch with the advantages of USB plug and play, support for USB mouse or digitizer, advanced touch response and accuracy, field flash updatability, and free drivers for most operating systems to enable low risk designs for a wide variety of touch sensing requirements.

The AR1100 supports large displays like industrial controls, self-service kiosks, and POS terminals, as well as smaller tablet displays, handheld consumer devices, and medical devices.

Resistive touch provides the advantages of easy integration, low total system cost and acceptance of finger, glove or stylus input, and USB communication is the industry standard for attaching peripherals to a computer. The AR1100 is an easy-to-integrate touch screen controller that meets all of these needs in a single-chip solution or production ready-board product. The device comes with free drivers for most major operating systems, making it easy for designers to quickly create low-risk touch interface solutions.

1.1 Applications

The AR1100 is suitable for any application that requires fast, accurate and reliable integration of touch – including, but not limited to:

- Mobile communication devices
- Personal Digital Assistants (PDA)
- Global Positioning Systems (GPS)
- Touch Screen Monitors
- KIOSK
- Media Players
- Portable Instruments
- Point of Sale Terminals

FIGURE 1-1: BLOCK DIAGRAM

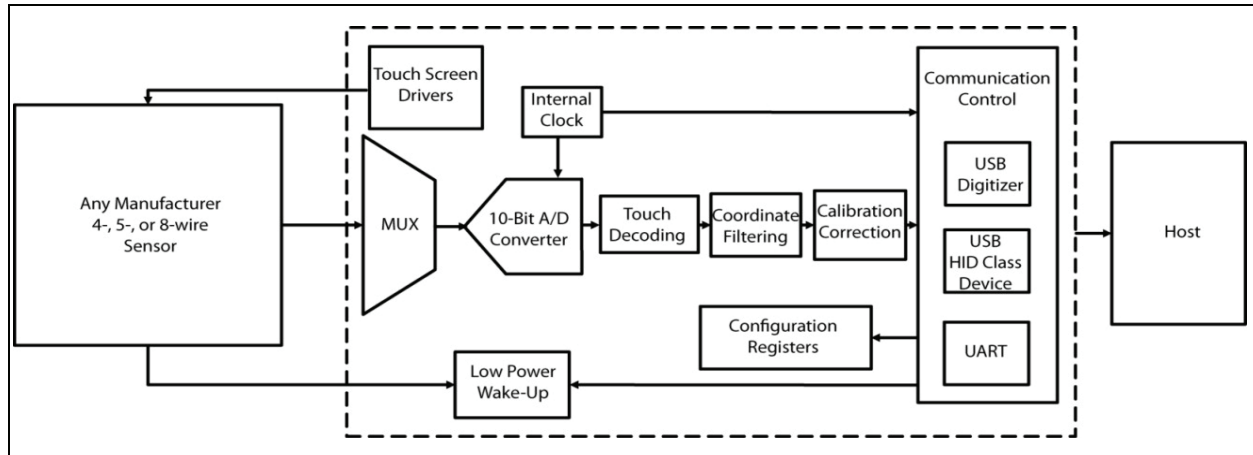

AR1100 RESISTIVE USB AND RS-232 TOUCH SCREEN CONTROLLER

NOTES:

2.0 IMPLEMENTATION – QUICK START

The AR1100 is designed to be a fully-functioning touch controller on power-up – no configuration is necessary and only minimal hardware support is needed to create a universal controller board (refer to simplified schematic).

The hard-coded defaults for the operational parameters are suitable for all but the most unique circumstances. A jumper on the MODE pin easily selects the sensor type (5-Wire or 4/8-Wire) and the Communication mode (USB or UART) is automatically detected and selected by the device. If USB is detected, the AR1100 automatically defaults to a HID-MOUSE, compatible with intrinsic drivers of standard operating systems. Any desired modifications to either the operating parameters or USB device type can be easily saved to internal nonvolatile memory to override the defaults.

AR1100 RESISTIVE USB AND RS-232 TOUCH SCREEN CONTROLLER

NOTES:

AR1100 RESISTIVE USB AND RS-232 TOUCH SCREEN CONTROLLER

3.0 HARDWARE

3.1 Pin Assignments

TABLE 3-1: PIN ASSIGNMENTS

Pin		Function	Description/Comments
SSOP, SOIC	QFN		
1	18	VDD	Power
2	19	OSC1	Oscillator
3	20	OSC2	Oscillator
4	1	MODE	GND: 5-Wire Open: 4-/8-Wire
5	2	LED	Led control
6	3	(Y+)	Sensor connection 4W: n/a 5W: n/a 8W: Y+
7	4	X+	Sensor connection
8	5	SY-	Sensor connection
9	6	SX+	Sensor connection
10	7	UART-TX	UART Transmit Data
11	8	WAKE	Wake pin
12	9	UART-RX	UART Receive Data
13	10	SX-	Sensor connection 4W: n/a 5W: WSX- 8W: SX-
14	11	X-	Sensor connection
15	12	Y+(SY+)	Sensor connection 4W: Y+ 5W: Y+ 8W: SY+
16	13	Y-	Sensor connection
17	14	VUSB	USB Internal Voltage Reference
18	15	USB-D-	USB data I/O
19	16	USB-D+	USB data I/O
20	17	Vss	GND

AR1100 RESISTIVE USB AND RS-232 TOUCH SCREEN CONTROLLER

3.2 Schematic

A simplified schematic is provided below. A detailed schematic and BOM is given in **FIGURE B-1: "Schematic"** and **FIGURE B-2: "Bill of Materials"**.

FIGURE 3-1: SIMPLIFIED SCHEMATIC

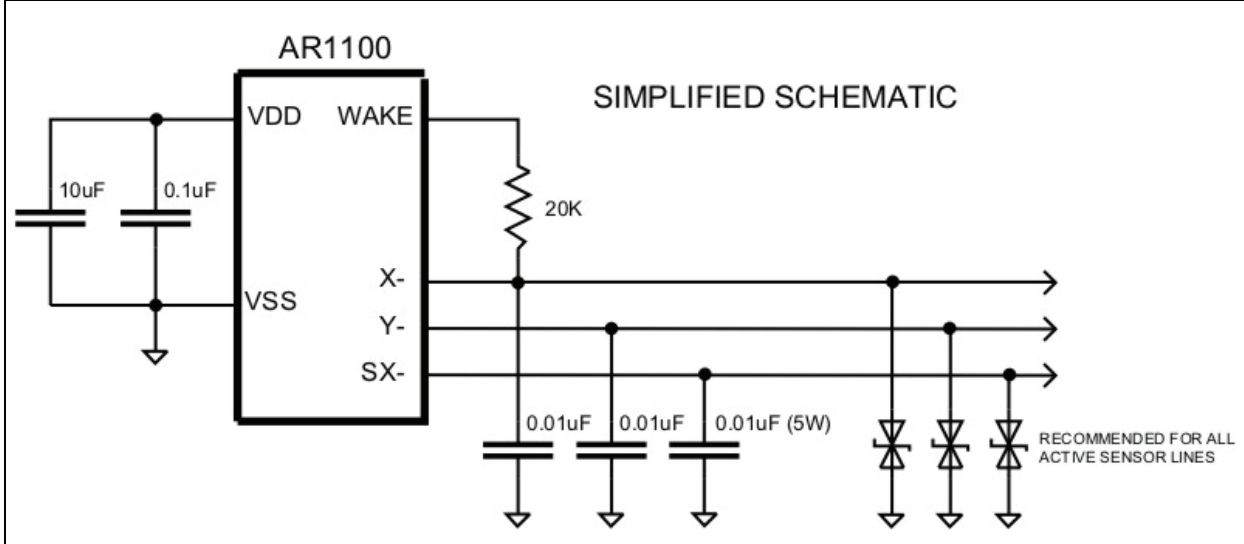

Note: Unused SENSOR pins should be grounded.

3.3 Sensor Attachment

AR1100 connections to the various sensor types are described graphically in **Figure 3-2**.

FIGURE 3-2: SENSOR EQUIVALENT CIRCUIT MODELS

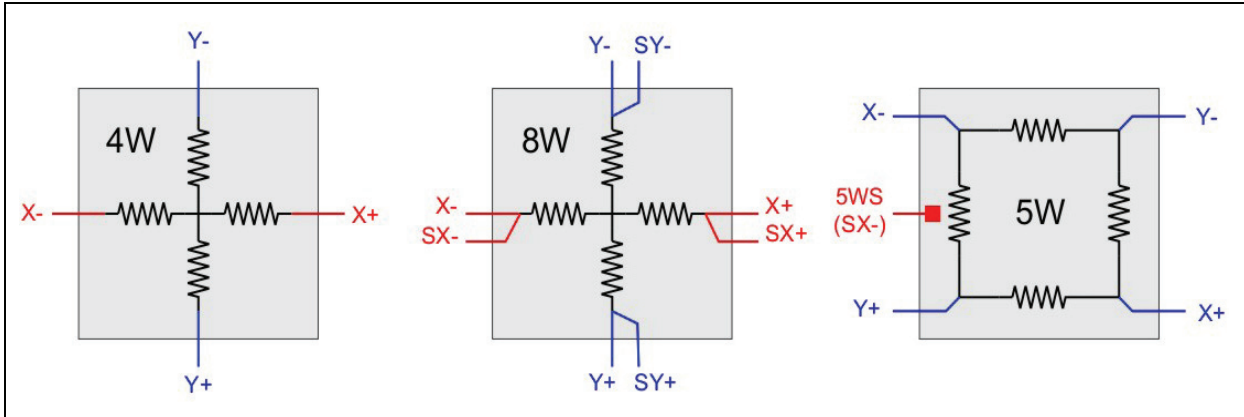

3.4 ESD Considerations

Suggested ESD protection is shown on the reference schematic (See **FIGURE B-1: “Schematic”**). Additional/alternate ESD countermeasures may be employed to meet application-specific requirements. Test to ensure the selected ESD protection does not degrade touch performance.

Note: ESD protection diodes are recommended for all active sensor lines but care should be taken to minimize capacitance. As an example, PESD5V0S1BA is recommended and used on reference designs due to its nominally-low 35 pF.

3.5 Noise Considerations

Touch sensor filtering capacitors are included in the reference design schematic (See **FIGURE B-1: “Schematic”**).

Note: Changing the value of the sensor filter capacitors may adversely affect touch performance.

AR1100 RESISTIVE USB AND RS-232 TOUCH SCREEN CONTROLLER

NOTES:

4.0 COMMUNICATION

4.1 Physical

The AR1100 supports UART and USB communication and will automatically detect the active mode between the two. Additionally, USB mode will enumerate as one of three 'devices'. The default USB device type is defined (and can be changed) by the configuration command and is saved in nonvolatile memory. The factory default is HID-MOUSE.

1. UART/Serial
2. HID-GENERIC
3. HID-MOUSE
4. HID-DIGITIZER

4.1.1 MODE DETECT/SELECT

To support auto-detection – the firmware and hardware resources for UART and USB are both functional at power-up until the active mode is determined by one of the following events.

1. USB successfully enumerates – result: USB is active
2. Valid communication is received via UART – result: UART is active
3. The Sleep timer has expired and USB has not yet enumerated – result: UART is active (by default)

<p>Note: Immediately after Reset, the AR1100 will not attempt to 'Sleep' for at least 45 seconds to allow time for USB enumeration – no matter the setting of the Sleep timer parameter.</p>

Once the active communication mode is determined, the 'inactive' mode is decommissioned to minimize power. The active communication mode will remain in force until the AR1100 is reset.

4.1.2 UART MODE

In UART mode, the AR1100 supports a simple, 2-wire (transmit/receive) asynchronous serial communication. The device does not support hardware handshaking but does employ a data protocol handshake described in the device command section. The host should be configured for 9600 BAUD, 8 data bits and 1 Stop bit.

AR1100 RESISTIVE USB AND RS-232 TOUCH SCREEN CONTROLLER

4.1.3 USB MODE

The USB can enumerate as one of three 'devices' (or device types) identified by a byte in EEPROM. See [Table 4-1](#).

TABLE 4-1: USB IDs

NAME	DESC	CLASS	VENDOR ID	PRODUCT ID	SPEED
HID-GENERIC	Proprietary (AR1000-style)	HID	x04D8	x0C01	FULL
HID-MOUSE	Mouse, absolute coordinates 0-4095	HID	x04D8	x0C02	FULL
HID-DIGITIZER	Single-input digitizer	HID	x04D8	x0C03	FULL

The HID-MOUSE and HID-DIGITIZER types are recognized by many host operating systems and will provide cursor movement with a touch.

The HID-GENERIC type is a proprietary style, which would require a custom software driver to support.

The controller defaults to the HID-MOUSE device type, unless it is commanded to enumerate as one of the other supported types.

Once enumerated, the USB device can be signaled/commanded to re-enumerate as the same device or to one of the other two. In processing the command, the AR1100 writes the desired USB device type to EEPROM prior to detaching from the bus and executing a Reset. The `SET_FEATURE` control transfer or a WRITE standard data transfer (via the Interrupt end point) is used to convey the command (described in [Section 5.0, Commands](#)).

Note: The HID-MOUSE requires `SET_FEATURE` and does not support a data `WRITE`.

4.2 Data Protocol

Data protocol utilizes multi-byte packet transfers in two categories/formats:

1. Touch reports
2. Command packets

4.2.1 TOUCH REPORTS

Touch reports always originate from the AR1100 and are transmitted in response to touch detection. The format of the touch report is mode-dependent.

The measurement resolution for touch coordinates is 10-bit. The measured values are shifted (multiplied by 4) and reported in a 12-bit format. In the reporting protocol, the Least Significant coordinate bits X1:X0 and Y1:Y0 will be zeros. The resulting full-scale range for reported touch coordinates is 0 to 4095.

4.2.1.1 Mode: UART, HID-GENERIC

The 'standard', 5-byte touch report is formatted as in [Table 4-2](#):

AR1100 RESISTIVE USB AND RS-232 TOUCH SCREEN CONTROLLER

TABLE 4-2: TOUCH REPORT FORMAT – GENERIC

BYTE	BIT							
	7	6	5	4	3	2	1	0
1	1	R	R	R	R	R	R	P
2	0	X6	X5	X4	X3	X2	X1	X0
3	0	0	0	X11	X10	X9	X8	X7
4	0	Y6	Y5	Y4	Y3	Y2	Y1	Y0
5	0	0	0	Y11	Y10	Y9	Y8	Y7

P Pen state - 1: Pen down - 0: Pen up
 R (Reserved)
 X X ordinate of touch location (12 bits)
 Y Y ordinate of touch location (12 bits)

Up to three touch reports are sent in response to each touch 'event' (events are defined as: pen down, pen up and pen move). A behavior is defined per event by the 'Touch mode' configuration parameter and described in [Table 4-3](#) below.

TABLE 4-3: TOUCH MODE OPTIONS – GENERIC

MODE	SUPPORTED EVENT			BEHAVIOR
	PD	PU	PM	
0	X	X	X	NO REPORT
1	X	X	X	REPORT (P=0)
2	X	X	X	REPORT (P=1)
3	X	X	X	REPORT (P=1), REPORT (P=0)
4	X	X		REPORT (P=0), REPORT (P=1), REPORT (P=0)
5	X	X		REPORT (P=0), REPORT (P=1)

PD Pen down
 PU Pen up
 PM Pen move
 Report Touch report

AR1100 RESISTIVE USB AND RS-232 TOUCH SCREEN CONTROLLER

4.2.1.2 Mode: HID-MOUSE

Touch report format:

TABLE 4-4: TOUCH REPORT FORMAT – MOUSE

BYTE	BIT							
	7	6	5	4	3	2	1	0
1	0	0	0	0	0	B3	B2	B1
2	X7	X6	X5	X4	X3	X2	X1	X0
3	0	0	0	0	X11	X10	X9	X8
4	Y7	Y6	Y5	Y4	Y3	Y2	Y1	Y0
5	0	0	0	0	Y11	Y10	Y9	Y8

- B1 Button 1 depressed
- B2 Button 2 depressed
- B3 Button 3 depressed
- X X ordinate of touch location (12 bits)
- Y Y ordinate of touch location (12 bits)

AR1100 RESISTIVE USB AND RS-232 TOUCH SCREEN CONTROLLER

4.2.1.3 Mode: HID-DIGITIZER

Touch report format:

TABLE 4-5: TOUCH REPORT FORMAT – DIGITIZER

BYTE	BIT							
	7	6	5	4	3	2	1	0
1	0	0	0	0	0	0	P	T
2	0	0	0	0	0	0	0	0
3	X7	X6	X5	X4	X3	X2	X1	X0
4	0	0	0	0	X11	X10	X9	X8
5	Y7	Y6	Y5	Y4	Y3	Y2	Y1	Y0
6	0	0	0	0	Y11	Y10	Y9	Y8

T Tip switch
P Proximity (in range) – always 1
X X ordinate of touch location (12 bits)
Y Y ordinate of touch location (12 bits)

For flexibility, the value and behavior of the ‘tip switch’ data entity (“T”) and touch reporting react to and is defined by the ‘Touch mode’ parameter (similar to ‘pen state’ bit in HID-GENERIC or UART).

TABLE 4-6: TOUCH MODE OPTIONS – DIGITIZER

MODE	SUPPORTED EVENT			BEHAVIOR
	PD	PU	PM	
0	X	X	X	NO REPORT
1	X	X	X	REPORT (T=0)
2	X	X	X	REPORT (T=1)
3	X	X	X	REPORT (T=1), REPORT (T=0)
4	X	X		REPORT (T=0), REPORT (T=1), REPORT (T=0)
5	X	X		REPORT (T=0), REPORT (T=1)

PD Pen down
PU Pen up
PM Pen move
Report Touch report

4.2.2 COMMAND PACKETS

PACKETS are used for all communications, other than touch reports (i.e., configuration/control). COMMAND packets (issued by the host) and RESPONSE packets (issued by the device) have identical framework but differ slightly in format, as described below. In standard operation, communication is initiated by the host then acknowledged by the device. In some diagnostic scenarios (not discussed here) – a COMMAND packet does not necessarily dictate a response from the device and, in other cases, a RESPONSE packet may be issued by the device unsolicited.

AR1100 RESISTIVE USB AND RS-232 TOUCH SCREEN CONTROLLER

4.2.2.1 Construction

GENERAL

The generic framework for all packets (Figure 4-1) is comprised of a SYNC byte, a SIZE byte and a DATA section. The DATA section has a maximum size of 255 total bytes.

FIGURE 4-1: PACKET FORMAT – GENERAL

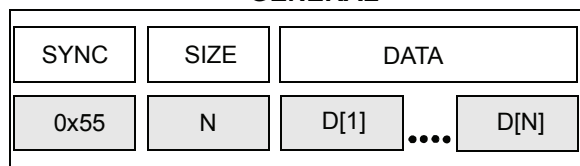

COMMAND

A COMMAND packet has a minimum of 3 bytes defined as SYNC, SIZE and CMND. The DATA section is command-dependant and can include up to 254 associated data bytes (D[1] – D[N]). See Figure 4-2.

FIGURE 4-2: PACKET FORMAT – COMMAND

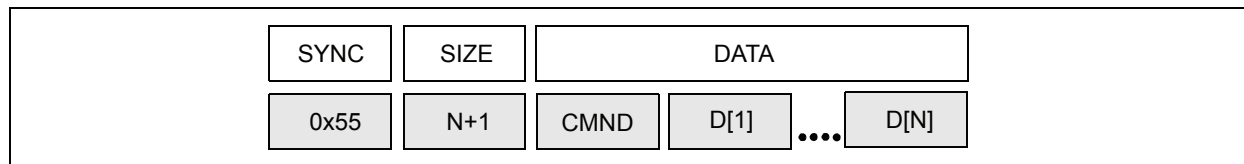

RESPONSE

A RESPONSE packet has a minimum of 4 bytes defined as SYNC, SIZE, STATUS and CMND. As with the COMMAND packet, the RESPONSE packet is command-dependant and can include up to 253 associated data bytes. In cases where the RESPONSE packet is in direct response to a COMMAND packet, the CMND byte is the same in both.

FIGURE 4-3: PACKET FORMAT – RESPONSE

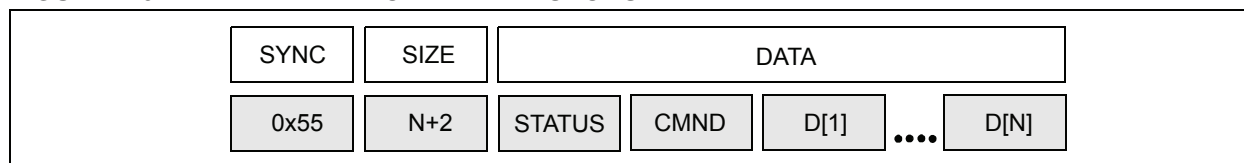

4.2.2.2 Mode: UART

In UART communication mode a complete COMMAND packet must be delivered before the packet 'time-out' timer expires (~250 ms). A packet 'time out' will cause any partial packet to be discarded and the packet parsing state controller to reset. Using this mechanism, the host can always ensure (re-establish) 'SYNC' by pausing for 250+ ms before sending another packet.

4.2.2.3 Mode: USB

Typically, a packet arrives (and is delivered) in a single, 64-byte (max.) USB buffer. Theoretically, a COMMAND packet can span multiple, physical USB buffers but will be subject to the packet time-out criteria described in the UART section. A RESPONSE packet will always be delivered in a single buffer and a buffer will never contain more than one.

4.2.2.4 Mode Capabilities

Only two of the four AR1100 communication modes, UART and HID-GENERIC, support 'low-level' operations such as:

1. Configuration
2. Calibration
3. Boot loading (field re-programming)

The remaining two communication modes, HID-MOUSE and HID-DIGITIZER, only support output of TOUCH REPORT(s) and only receive (respond to) mode change command(s). They can be supported by intrinsic operating system driver(s). To configure, calibrate and/or reprogram these two devices, the host must cause them to re-enumerate as HID-GENERIC. Once the low-level operations are complete, the host can then re-configure back to the desired device.

AR1100 RESISTIVE USB AND RS-232 TOUCH SCREEN CONTROLLER

NOTES:

5.0 COMMANDS

In normal operation, the AR1100 automatically returns 'touch reports' in response to a touch – no 'prompting' is required from the host. The following command set can be used to configure the parameters used to 'fine-tune' the operation. To prevent touch reports from interfering with these commands, it is recommended that TOUCH_DISABLE be executed prior to any other command(s) and the TOUCH_ENABLE command be used as the last step to return the AR1100 to normal operation.

5.1 Summary

Table 5-1 summarizes the standard command set.

TABLE 5-1: COMMAND SUMMARY

CMND	NAME	DESCRIPTION
0x12	TOUCH_ENABLE	Enable TOUCH reporting
0x13	TOUCH_DISABLE	Disable TOUCH reporting
0x14	CALIBRATE	Execute Calibrate routine
0x20	REG_READ	Read register(s)
0x21	REG_WRITE	Write register(s)
0x28	EE_READ	Read EE location(s)
0x29	EE_WRITE	Write EE location(s)
0x2B	EE_READ_PARAMS	Read parameter set (from EE to RAM)
0x23	EE_WRITE_PARAMS	Write parameter set (from RAM to EE)

Table 5-2 summarizes the STATUS byte in the RESPONSE packet.

TABLE 5-2: STATUS SUMMARY

STATUS	NAME	DESCRIPTION
0x00	OK	No error
0x01	UNRECOGNIZED	Unrecognized command
0x04	TIMEOUT	Packet time out
0x05	EPPARAMS_ERR	Error reading EEPROM parameters
0xFC	CAL_CANCEL	Calibration sequence cancelled

AR1100 RESISTIVE USB AND RS-232 TOUCH SCREEN CONTROLLER

5.2 Command: TOUCH_ENABLE

Enable touch reporting.

COMMAND PACKET:

TABLE 5-3: COMMAND: TOUCH_ENABLE

BYTE#	VALUE	DESCRIPTION
1	0x55	SYNC
2	0x01	SIZE
3	0x12	COMMAND

RESPONSE PACKET:

TABLE 5-4: RESPONSE: TOUCH_ENABLE

BYTE#	VALUE	DESCRIPTION
1	0x55	SYNC
2	0x02	SIZE
3	STATUS	STATUS
4	0x12	COMMAND

5.3 Command: TOUCH_DISABLE

Disable touch reporting.

COMMAND PACKET:

TABLE 5-5: COMMAND: TOUCH_DISABLE

BYTE#	VALUE	DESCRIPTION
1	0x55	SYNC
2	0x01	SIZE
3	0x13	COMMAND

RESPONSE PACKET:

TABLE 5-6: RESPONSE: TOUCH_DISABLE

BYTE#	VALUE	DESCRIPTION
1	0x55	SYNC
2	0x02	SIZE
3	STATUS	STATUS
4	0x13	COMMAND

5.4 Command: CALIBRATE

The CALIBRATE command initiates the controller-based calibration sequence. A RESPONSE packet is returned for each calibration point touched.

COMMAND PACKET

TABLE 5-7: COMMAND: CALIBRATE

BYTE#	VALUE	DESCRIPTION
1	0x55	SYNC
2	0x02	BYTE COUNT
3	0x14	COMMAND
4	TYPE	0x01: 4-Point – Full interpolation 0x02: 9-Point 0x03: 25-Point 0x04: 4-Point (AR1000 style)

RESPONSE PACKET (for each calibration point touched, then released):

TABLE 5-8: RESPONSE: CALIBRATE

BYTE#	VALUE	DESCRIPTION
1	0x55	SYNC
2	0x02	SIZE
3	STATUS	STATUS
4	0x14	COMMAND

5.5 Command: REG_READ

Read one or more operational registers.

COMMAND PACKET:

TABLE 5-9: COMMAND: REG_READ

BYTE#	VALUE	DESCRIPTION
1	0x55	SYNC
2	0x04	SIZE
3	0x20	COMMAND
4	0x00	REGISTER ADDRESS (MSB)
5	ADR	REGISTER ADDRESS (LSB)
6	N	NUMBER OF BYTES TO READ

RESPONSE PACKET:

TABLE 5-10: RESPONSE: REG-READ

BYTE#	VALUE	DESCRIPTION
1	0x55	SYNC
2	N+2	SIZE
3	STATUS	STATUS
4	0x20	COMMAND
5	REG[ADR]	REGISTER VALUE
...	...	REGISTER VALUE(S)
4+N	REG[ADR+N-1]	REGISTER VALUE

AR1100 RESISTIVE USB AND RS-232 TOUCH SCREEN CONTROLLER

5.6 Command: REG_WRITE

Write one or more operational registers.

COMMAND PACKET:

TABLE 5-11: COMMAND: REG_WRITE

BYTE#	VALUE	DESCRIPTION
1	0x55	SYNC
2	N+2	SIZE (N = # of REGS to WRITE)
3	0x21	COMMAND
4	0x00	REGISTER ADDRESS (MSB)
5	ADR	REGISTER ADDRESS (LSB)
6	REG[ADR]	REGISTER VALUE
...	...	REGISTER VALUE(S)
5+N	REG[ADR+N-1]	REGISTER VALUE

RESPONSE PACKET:

TABLE 5-12: RESPONSE: REG_WRITE

BYTE#	VALUE	DESCRIPTION
1	0x55	SYNC
2	0x02	SIZE
3	STATUS	STATUS
4	0x21	COMMAND

5.7 Command: EE_READ

Read one or more bytes from EEPROM.

COMMAND PACKET:

TABLE 5-13: COMMAND: EE_READ

BYTE#	VALUE	DESCRIPTION
1	0x55	SYNC
2	0x04	SIZE
3	0x28	COMMAND
4	0x00	EE ADDRESS (MSB)
5	ADR	EE ADDRESS (LSB)
6	N	Number of bytes to read

RESPONSE PACKET:

TABLE 5-14: RESPONSE: EE_READ

BYTE#	VALUE	DESCRIPTION
1	0x55	SYNC
2	N+2	SIZE (N = # of BYTES to WRITE)
3	STATUS	STATUS
4	0x28	COMMAND
5	EE[ADR]	EE VALUE
...	...	EE VALUE VALUE(S)
4+N	EE[ADR+N-1]	EE VALUE

5.8 Command: EE_WRITE

Write one or more bytes to EEPROM.

COMMAND PACKET:

TABLE 5-15: COMMAND: EE_WRITE

BYTE#	VALUE	DESCRIPTION
1	0x55	SYNC
2	4+N	SIZE (N = # of REGS to WRITE)
3	0x29	COMMAND
4	0x00	EE ADDRESS (MSB)
5	ADR	EE ADDRESS (LSB)
6	EE[ADR]	EE VALUE
...	...	EE VALUE(S)
5+N	EE[ADR+N-1]	EE VALUE

RESPONSE PACKET:

TABLE 5-16: RESPONSE: EE_WRITE

BYTE#	VALUE	DESCRIPTION
1	0x55	SYNC
2	2	SIZE
3	STATUS	STATUS
4	0x29	COMMAND

AR1100 RESISTIVE USB AND RS-232 TOUCH SCREEN CONTROLLER

5.9 Command: EE_READ_PARAMS

Read entire set of operational parameters from EEPROM to RAM.

COMMAND PACKET:

TABLE 5-17: COMMAND: EE_READ_PARAMS

BYTE#	VALUE	DESCRIPTION
1	0x55	SYNC
2	0x01	SIZE
3	0x23	COMMAND

RESPONSE PACKET:

TABLE 5-18: RESPONSE: EE_READ_PARAMS

BYTE#	VALUE	DESCRIPTION
1	0x55	SYNC
2	2	SIZE
3	STATUS	STATUS
4	0x23	COMMAND

5.10 Command: EE_WRITE_PARAMS

Write entire set of operational parameters to EEPROM from RAM.

COMMAND PACKET:

TABLE 5-19: COMMAND: EE_WRITE_PARAMS

BYTE#	VALUE	DESCRIPTION
1	0x55	SYNC
2	0x01	SIZE
3	0x2B	COMMAND

RESPONSE PACKET:

TABLE 5-20: RESPONSE: EE_WRITE_PARAMS

BYTE#	VALUE	DESCRIPTION
1	0x55	SYNC
2	2	SIZE
3	STATUS	STATUS
4	0x2B	COMMAND

5.11 Command: USB_MODE_GENERIC

Set default USB mode (device type) to "HID-GENERIC". Mode HID-GENERIC is required for low-level configuration commands, calibration and boot load operations. No RESPONSE packet is returned.

COMMAND PACKET:

TABLE 5-21: COMMAND: USB_MODE_GENERIC

BYTE#	VALUE	DESCRIPTION
1	0x55	SYNC
2	0x01	SIZE
3	0x70	COMMAND

RESPONSE PACKET:

None.

5.12 Command: USB_MODE_MOUSE

Set default USB mode (device type) to 'HID-MOUSE'.

COMMAND PACKET:

TABLE 5-22: COMMAND: USB_MODE_MOUSE

BYTE#	VALUE	DESCRIPTION
1	0x55	SYNC
2	0x01	SIZE
3	0x71	COMMAND

RESPONSE PACKET:

None.

5.13 Command: USB_MODE_DIGITIZER

Set default USB mode (device type) to 'HID-DIGITIZER'.

COMMAND PACKET:

TABLE 5-23: COMMAND: USB_MODE_DIGITIZER

BYTE#	VALUE	DESCRIPTION
1	0x55	SYNC
2	0x01	SIZE
3	0x72	COMMAND

RESPONSE PACKET:

None.

AR1100 RESISTIVE USB AND RS-232 TOUCH SCREEN CONTROLLER

6.0 CONFIGURATION REGISTERS

TABLE 6-1: CONFIGURATION REGISTER SUMMARY

ADDR	NAME	DESCRIPTION	7	6	5	4	3	2	1	0	DFLT
0x00	RisetimeCapTime-out	*170 usec	Value of: 0-255								0x18
0x01	RisetimeQuick	*10 usec	Value of: 0-255								0x02
0x02	TouchThreshold	8-bit ADC – touch_check()	Value of: 0-255								0x80
0x03	SensitivityFilter	8-bit ADC	Value of: 0-255								0x04
0x04	SamplingFast	# of ADC samples/touch to average	Value of: 1, 2, 4, 8, 16, 32, 64, 128								0x04
0x05	SamplingSlow	# of ADC samples/touch to average	Value of: 1, 2, 4, 8, 16, 32, 64, 128								0x08
0x06	AccuracyFilterFast	# of touch positions to average	Value of: 1-8								0x08
0x07	AccuracyFilter-Slow	# of touch positions to average	Value of: 1-8								0x08
0x08	SpeedThreshold	8-bit ADC (raw touch coordinates)	Value of: 0-255								0x03
0x09	DitherFilter	size of anti-dithering window 1/4096 of sensor dim.	Value of: 0-255								0x00
0x0A	SleepDelay	*250 msec	Value of: 0-255								0x00
0x0B	PenUpDelay	touch process loop count	Value of: 0-255								0x02
0x0C	TouchMode	(Note 3)	PD2	PD1	PD0	PM1	PM0	PU2	PU1	PU0	0xB1
0x0D	TouchOptions	(Note 1)	TEN	VCF	—	C	DRT	—	48W	CALE	0x89
0x0E	CalibrationInset	2x % sensor dimension - units: 1/256 (e.g. 64=25%)	Value of: 1-128								0x40
0x0F	PenStateReport-Delay	*170 usec	Value of: 0-255								0x04
0x10	Reserved	—	—								0x00
0x11	TouchReportDelay	*0.5 msec	Value of: 0-255								0x00
0x12	RisetimeDefault	*21 usec	Value of: 0-255								0x80
0x13	RisetimeModifier	(value-128) * 10 usec (i.e., 128 = 0, 127 = -1, 129 = +10)	Value of: 0-255								0x80
0x14	Status	(Note 2)	TCHK	EEV	CALV	JMP	DRT	8W	5W	4W	0x00
0x15	Debug	(Note 4)	—	—	—	RT	RTC	RTR	—	—	0x00

Note 1: OPTIONS/FLAGS: TEN (Touch Enable); VCF (Verbose Cal Feedback); DRT (Dynamic Risetime Enable); 48W (0 = 4-Wire, 1 = 8-Wire); CALE (Calibration Enable);

2: STATUS (READ ONLY): TCHK (Result of Touch CHK DIAG); EEV (Params in EEPROM used); CALV (Calibration valid); JMP (State of mode Jumper); DRT (DYN RISE TIME CAP MEAS'D); 8W (Configured for 8W Sensor); 5W (Configured for 5W Sensor); 4W (Configured for 4W Sensor);

3: TOUCH MODE(S) (specified for each event: PD, PM and PU): 0: no report(s) issued; 1: report (P = 0); 2: report (P = 1); 3: report (P = 1), report (P = 0); 4: report (P = 0), report (P = 1); report (P = 0), 5: report (P = 0), report (P = 1);

4: DEBUG FLAGS (optional): RT (Risetime Report); RTC (Risetime CAP Report); RTR (Risetime RES Report).

6.1 Register 0: RisetimeCapTimeout

(ADVANCED – DO NOT CHANGE)

The RisetimeCapTimeout value is used in the proprietary algorithm associated with sensor characteristics.

6.2 Register 1: RisetimeQuick

(ADVANCED – DO NOT CHANGE)

The RisetimeQuick value is used in the proprietary algorithm associated with sensor characteristics.

6.3 Register 2: TouchThreshold

The TouchThreshold value sets the threshold for detecting a touch condition. A larger value relaxes the criteria for detecting a touch and a small value is more demanding.

6.4 Register 3: SensitivityFilter

The SensitivityFilter value sets a criteria for touch 'stability'. A larger value is more sensitive to a touch but possibly less 'stable'. A smaller value requires a 'harder' touch but provides a more stable position.

6.5 Register 4: SamplingFast

The SamplingFast register sets the level of touch measurement sample averaging, when touch movement is determined to be fast (reference SpeedThreshold). A lower value will result in faster reporting but may be more susceptible to noise in touch positions. A higher value will reduce the report rate but provide more immunity to random noise in the reported touch positions.

6.6 Register 5: SamplingSlow

The SamplingFast register sets the level of touch measurement sample averaging, when touch movement is determined to be slow (reference SpeedThreshold). A lower value will result in faster reporting but may be more susceptible to noise in touch positions. A higher value will reduce the report rate but provide more immunity to random noise in the reported touch positions.

6.7 Register 6: AccuracyFilterFast

The AccuracyFilterFast sets the level of touch measurement accuracy enhancement used when the touch movement is determined to be 'fast' (reference SpeedThreshold). A lower value will increase touch position resolution but may exhibit more noise in reported touch positions. A higher value will decrease touch position resolution but increase immunity to noise in reported touch positions.

6.8 Register 7: AccuracyFilterSlow

The AccuracyFilterFast sets the level of touch measurement accuracy enhancement used when the touch movement is determined to be 'slow' (reference SpeedThreshold). A lower value will increase touch position resolution but may exhibit more noise in reported touch positions. A higher value will decrease touch position resolution but increase immunity to noise in reported touch positions.

6.9 Register 8: SpeedThreshold

The SpeedThreshold value sets the threshold for touch movement to be considered as 'slow' or 'fast'. A lower value reduces the touch movement speed that will be considered 'fast'. A higher value has the opposite effect.

6.10 Register 9: DitherFilter

The DitherFilter value sets the threshold to prevent the reported touch location from changing during what is thought to be a stationary touch. The computed touch position must change by an amount greater than DitherFilter (either X or Y) before the reported position changes.

6.11 Register 10: SleepDelay

The SleepDelay value sets the time interval (with no touch or host communication) that will cause the AR1100 to enter a low-power Sleep mode (UART Communication mode only).

6.12 Register 11: PenUpDelay

The PenUpDelay sets the time required for a pen-up event/condition before the controller will send a touch report with a pen-up status – effectively debouncing pen up. The delay timer resets if a pen-down condition is detected before the timer expires. A lower value will increase the responsiveness of the controller to pen up. A higher value will decrease the responsiveness.

6.13 Register 12: TouchMode

The TouchMode value defines the action taken by the controller in response to the three touch events/states (i.e., (1) pen down, (2) pen movement and (3) pen up). A code is specified for each event to specify one of 6 predefined actions. As can be seen in the footnotes of [Table 6-1](#), several actions specify a sequence of multiple touch reports. Each report in a multiple-touch sequence can be spaced in time by parameter PenStateReportDelay.

TouchMode[7:5] = PD[2:0] Response to event PD (PEN DOWN)

b000	No touch report issued in response to the event
b001	Touch report w/ P=0
b010	Touch report w/ P=1
b011	Touch report w/ P=1, then Touch report w/ P=0
b100	Touch report w/ P=0, then Touch report w/ P=1, then Touch report w/ P=0
b101	Touch report w/ P=0, then Touch report w/ P=1

TouchMode[4:3] = PM[1:0] Response to event PM (PEN MOVEMENT)

b000	No touch report issued in response to the event
b001	Touch report w/ P=0
b010	Touch report w/ P=1

TouchMode[2:0] = PU[2:0] Response to event PU (PEN UP)

b000	No touch report issued in response to the event
b001	Touch report w/ P=0
b010	Touch report w/ P=1
b011	Touch report w/ P=1, then Touch report w/ P=0
b100	Touch report w/ P=0, then Touch report w/ P=1, then Touch report w/ P=0
b101	Touch report w/ P=0, then Touch report w/ P=1

6.14 Register 13: TouchOptions

The TouchOptions register contains several bit flags corresponding to options in operation.

TouchOptions[7:7]	1: Set TOUCH_ENABLE as the default power-up state
TouchOptions[6:6]	1: Enable verbose mode for calibration feedback
TouchOptions[3:3]	1: Enable proprietary dynamic rise time algorithm
TouchOptions[1:1]	1: Select 8W, 0: Select 4W (if MODE input = VDD)
TouchOptions[0:0]	1: Enable 'calibrated' touch reports, 0: Enable 'raw' touch reports

6.15 Register 14: CalibrationInset

The CalibrationInset value specifies the 'inset' (margin) from the edge of the sensor to the perimeter calibration points. The remaining calibration points (for 9P and 25P) are evenly spaced between the margins. The inset is in units of 1/256 of the sensor dimension(s) and is 2x the margin – e.g. a value of 64 is 64/256ths of the screen dimension (25%) – each margin (top, bottom, left, right) is 12.5%.

6.16 Register 15: PenStateReportDelay

The PenStateReportDelay value sets the time delay between successive touch reports in a multiple-report sequence called for by TouchModes.

6.17 Register 17: TouchReportDelay

The TouchReportDelay value sets the time delay between successive touch reports. This can be used to reduce the volume/speed of touch reports, thereby reducing the burden on the host to process the touch reports.

6.18 Register 18: RisetimeDefault

(ADVANCED – DO NOT CHANGE)

The RisetimeModifier value is used in the proprietary algorithm measuring and reacting to sensor characteristic(s).

6.19 Register 19: RisetimeModifier

(ADVANCED – DO NOT CHANGE)

The RisetimeModifier value is used in the proprietary algorithm measuring and reacting to sensor characteristic(s).

6.20 Register 20: Status

The STATUS register provides useful feedback to the host on AR1100 operational status.

Status[7:7]	TCHK	Result of touch check diagnostic
Status[6:6]	EEV	Parameters in EEPROM were valid and automatically loaded
Status[5:5]	CALV	Calibration valid (EEPROM contains valid cal coefficients)
Status[4:4]	JMP	State of mode input 1: open (jumper off), 0: grounded (jumper on)
Status[3:3]	DRT	Dynamic risetime CAP successfully measured
Status[2:2]	8W	Configured for 8W sensor (4W will also be set)
Status[1:1]	5W	Configured for 5W sensor
Status[0:0]	4W	Configured for 4W sensor

6.21 Register 21: Debug

The Debug register contains bit flags enabling various debug functions.

7.0 OPERATION

7.1 Configuration

The AR1100 is operational out of the box using factory defaults. Some applications may have special needs that require changes to those factory settings (parameter registers). This is easily accomplished using the commands described in [Section 5.0, Commands](#). The recommended procedure is as follows:

1. Issue command: `TOUCH_DISABLE` (disables touch reports so as not to interfere)
2. Issue command: `REG_WRITE`, as needed, to modify the value of selected parameter registers
3. Issue command: `EE_WRITE_PARAMS` (optional) to archive new register values as 'defaults'
4. Issue command: `TOUCH_ENABLE` (to re-enable touch reports)

Note: Configuration commands are supported only in UART and HID-GENERIC communication modes. Refer to [Section 7.6, USB Mode Change](#).

7.2 Calibration

7.2.1 INTRODUCTION

Calibration enables the AR1100 to issue touch reports that (1) correct/modify sensor orientation and (2) precisely map the reported touch location to the physical dimensions of the underlying display device. The

AR1100 has the option of either reporting RAW touch reports or utilizing calibration information to report CALIBRATED touch reports. Configuration register, "TouchOption", contains bit flag "CALE" (calibration enable) to choose between the two.

The calibration process requires the operator to sequentially touch a series of targets [crosshairs] presented by the host on the display device. The AR1100 archives the raw-touch data from each calibration touch point in EEPROM, then uses that data in normal operation to process "raw" data into "calibrated" data.

Note: Calibration is supported only in UART and HID-GENERIC communication modes. Refer to [Section 7.6, USB Mode Change](#).

7.2.2 CONFIGURATION

Both the host and device must know/understand the geometry of the calibration point matrix. The AR1100 defines the matrix by (1) an INSET and (2) calibration TYPE i.e., number of points (4, 9 or 25). The TYPE is set by the argument of the calibration command. The INSET is pre-defined by the Configuration register *CalibrationInset*.

The INSET is predefined as '64' – interpreted as 64/256 (i.e., 25%) of the sensor width or height. This defines the 'margin' on the perimeter of the calibration point matrix. Interior calibration points are spaced equally between the margins (e.g., for the 9-point calibration in the illustration – point 2 is half-way between points 1 and 3). See [Figure 7-1](#).

FIGURE 7-1: CALIBRATION POINT LAYOUT

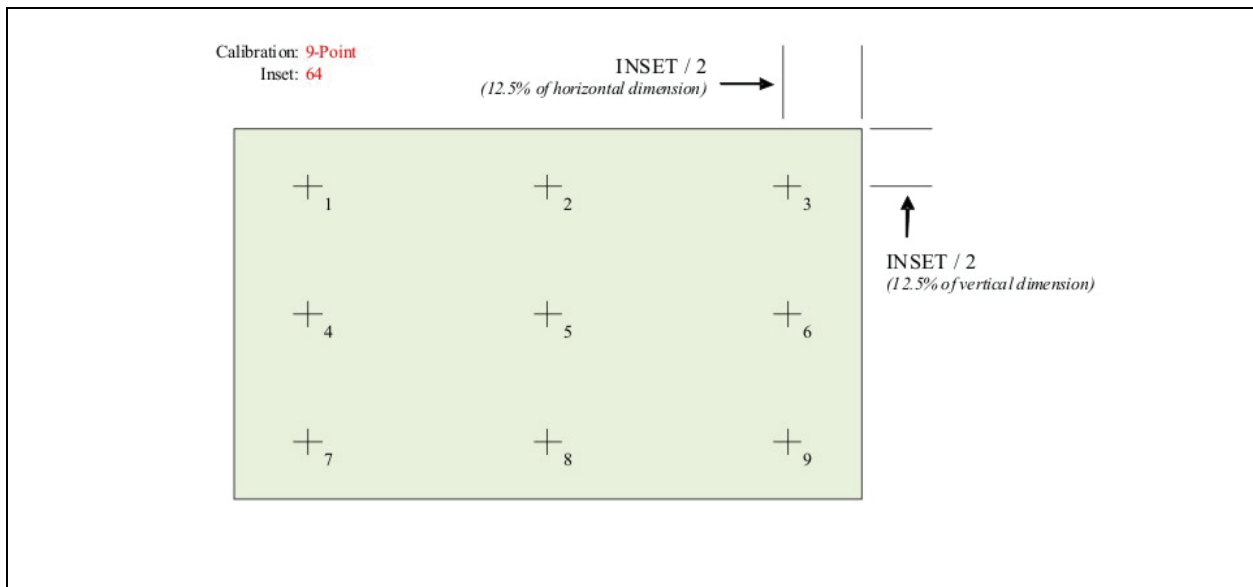

AR1100 RESISTIVE USB AND RS-232 TOUCH SCREEN CONTROLLER

7.2.3 EXECUTION

The host first commands the AR1100 to enter Calibration mode, then subsequently presents the calibration point targets, one at a time, from left to right, top to bottom. The AR1100 returns a calibration command response packet each time the operator touches a target – signaling the host to proceed. Upon completion, the data from the calibration process is saved to EEPROM and available for use by the AR1100 during normal operation. Calibration process can be aborted by the host by simply issuing any command. That command will be ignored but the response to that command will have a status byte that indicates that calibration had terminated prematurely (see below).

7.2.3.1 Normal sequence

- host issues calibration command: <0x55> <0x02> <0x14> <type>
- host present 1st target
- operator touches (and releases) sensor at 1st target
- device issues response packet: <0x55> <0x02> <0x00> <0x14>
- host presents 2nd target
- operator touches (and releases) sensor at 2nd target
- device issues response packet: <0x55> <0x02> <0x00> <0x14>
- ...
- host presents last target
- operator touches (and releases) sensor at last target
- device issues response packet: <0x55> <0x02> <0x00> <0x14>
- host terminates the target display
- device returns to normal operation

7.2.3.2 Aborted sequence

- host issues calibration command: <0x55> <0x02> <0x14> <type>
- host presents 1st target
- operator touches (and releases) sensor at 1st target
- device issues response packet: <0x55> <0x02> <0x00> <0x14>

- host presents 2nd target
- operator touches (and releases) sensor at 2nd target
- device issues response packet: <0x55> <0x02> <0x00> <0x14>
- host issues TOUCH_ENABLE command to abort calibration: <0x55> <0x01> <0x12>
- device issues response packet: <0x55> <0x02> <0xFC> <0x12>
- (status 0xFC indicates calibration termination)
- host terminates the target display
- device returns to normal operation

7.2.3.3 Normal sequence (verbose)

The VCF (Verbose Calibration Feedback) bit in the TouchOptions Configuration register enables 'verbose' communication from the AR1100 in Calibration mode as evidenced below:

- host sets 'verbose' flag in Configuration register i.e., TouchOptions[VCF]
- host issues calibration command: <0x55> <0x02> <0x14> <type>
- device responds: <0x55> <0x07> <0x00> <0x14> <0xFE> <0xFF> <0xFF> <0xYY> <0xYY>

0xFE indicates 'enter' Calibration mode, XX and YY are don't care.

- host presents 1st target
- operator touches (and releases) sensor at 1st target
- device issues response packet: <0x55> <0x07> <0x00> <0x14> <0x00> <0xFF> <0xFF> <0xYY> <0xYY>
- the 5th byte indicates the calibration point 0x00 (the 1st)

0xFFFF and 0xYYYY are RAW coordinates of the touch point (16-bit, little endian)

- host presents 2nd target
- operator touches (and releases) sensor at 2nd target
- device issues response packet: <0x55> <0x07> <0x00> <0x14> <0x01> <0xFF> <0xFF> <0xYY> <0xYY>
- The 5th byte indicates the calibration point 0x01 (the 2nd)

0xFFFF and 0xYYYY are RAW coordinates of the touch point (16-bit, little endian)

...

- host presents last target (9th in this example)
- operator touches (and releases) sensor at last target <0x55> <0x07> <0x00> <0x14> <0x08> <0xXX> <0xXX> <0xYY> <0xYY>
- the 5th byte indicates the calibration point 0x08 (the 9th)
- 0xXXXX and 0xYYYY are RAW coordinates of the touch point (16-bit, little endian)
- device indicates exit from calibration mode with <0x55> <0x07> <0x00> <0x14> <0xFF> <0xXX> <0xXX> <0xYY> <0xYY>

0xFF indicates 'exit' Calibration mode, XX and YY are don't care

- host terminates the target display
- device returns to normal operation

7.3 Sleep

The AR1100 supports a low-power, Sleep mode used to conserve power when the device is not in use.

When in UART Communication mode, Sleep mode is activated after a specified time interval (parameter register: SleepDelay) during which no touch or communication took place. When in Sleep, the device can be awakened by a touch or by any communication from the host. The first byte of communication used to wake up the device will be lost/ignored.

When in USB Communication mode, Sleep mode is activated by a USB SUSPEND control transfer from the host – the SleepDelay timer has no effect. Optionally, if the host is configured to allow the device to awaken the host (USB REMOTE WAKE-UP), the host will preface the USB SUSPEND with a control transfer to enable remote wake-up from the device. In this situation, a touch can awaken the host; otherwise, only a RESUME condition from the host will wake-up the AR1100.

7.4 Configure Sensor Type

The AR1100 must be configured for the sensor type connected (i.e., 4W, 5W or 8W) using a combination of the MODE input pin and configuration parameter TouchOptions. For a 5W sensor, the mode input pin must be grounded. For a 4W or 8W sensor, the mode input pin should be open/disconnected. Additionally, bit 1 in Configuration register TouchOptions is used to further select between 4W and 8W.

As seen in [FIGURE B-1: "Schematic"](#), the MODE pin is typically connected to a hardware jumper (J1). Because this pin is equipped with an internal pull-up resistor, it can be grounded with a jumper or simply left disconnected (no jumper).

7.5 LED

The LED provides an indication of controller status. As summarized in [Table 7-1](#), a 'fast' blink indicates that a touch is detected, and a 'slow' blink indicates no touch.

FIGURE 7-2: LED SCHEMATIC

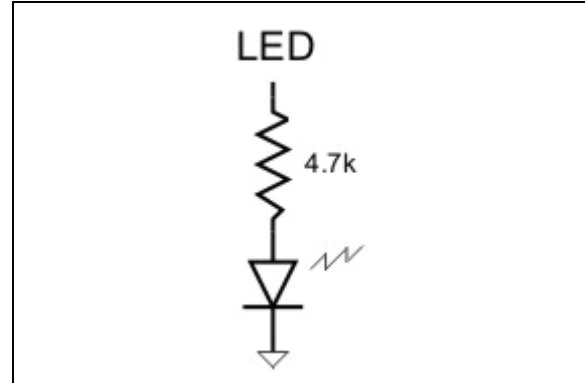

TABLE 7-1: LED INDICATOR

Behavior	Status
LED blinks slowly (once per second)	Controller is powered, awake and no touch is detected
LED blinks rapidly (5 times per second)	Controller detects a touch
LED is off	Controller has no power or is asleep (suspended)

7.6 USB Mode Change

Low-level operations (configuration, calibration, boot load) are supported in only 2 of the 4 communication modes (i.e., UART and HID-GENERIC). If the AR1100 is operating in HID-MOUSE or HID-DIGITIZER mode, it must be configured to HID-GENERIC for the low-level operations, then reconfigured back to the desired (default) device type.

Three 3-byte commands are provided to assign the USB device type (refer to [Section 5.0, Commands](#)).

1. USB_MODE_GENERIC
2. USB_MODE_MOUSE
3. USB_MODE_DIGITIZER

Each command sets the default USB device type (in nonvolatile memory), then resets the AR1100 – causing it to re-enumerate. All three device types will accept the mode change commands as either a SET_FEATURE control transfer or a standard WRITE data transfer (via the interrupt-end point). The HID-MOUSE device under MS Windows® may be limited to SET_FEATURE only.

AR1100 RESISTIVE USB AND RS-232 TOUCH SCREEN CONTROLLER

NOTES:

8.0 BOOT LOADER

The boot load process and associated commands enables the host to reprogram the AR1100. Because the size of the Flash program memory cannot accommodate both a boot load section and application section, the AR1100 is programmed in sections using 3 passes. With each pass, a USB device will necessarily re-enumerate.

Note: The boot load operation is supported only in UART and HID-GENERIC communication modes. Refer to [Section 7.6, USB Mode Change](#).

Note: A stand-alone software utility is available from Microchip to facilitate the boot loading operation. This functionality is also available with the Microchip AR Configuration Utility.

Passes:

1. Program temporary boot load application into upper memory
2. Execute from temporary boot load application to program the lower half of the new application
3. Execute from the lower half of the new application to program the upper half

This process is illustrated in a more detail in [Figure 8-1](#) below.

FIGURE 8-1: BOOT LOADING SEQUENCE

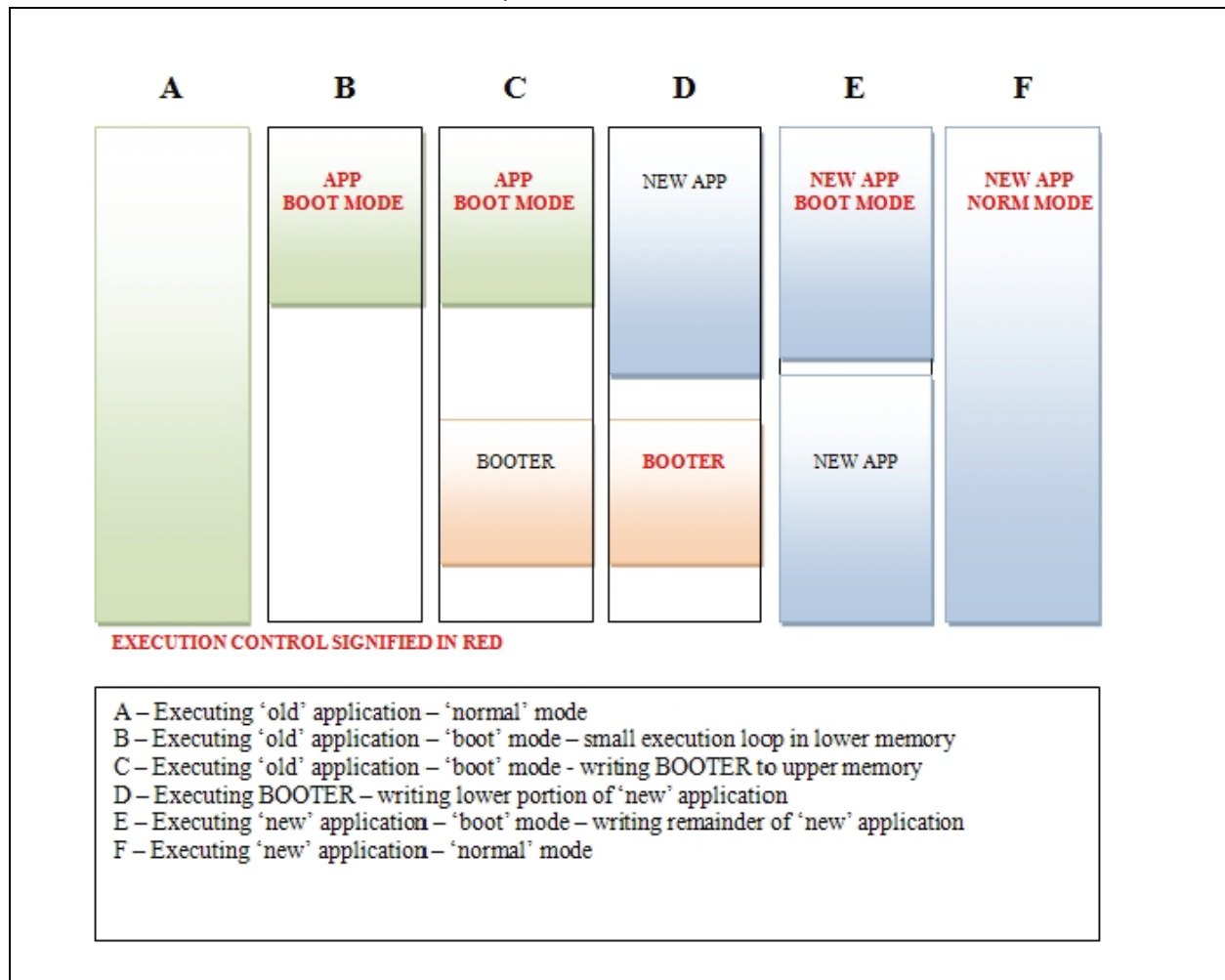

AR1100 RESISTIVE USB AND RS-232 TOUCH SCREEN CONTROLLER

8.1 Command Summary

The boot load operation uses the same data format/protocol as the touch application. Commands are described below.

TABLE 8-1: COMMAND SUMMARY

CMND	NAME	DESCRIPTION
0x01	VERSION	Return version number and mode
0xF0	RESET	Software device Reset
0xF1	INIT	Initialize boot loader
0xF2	WRITE	Write-memory contents
0xF3	READ	Read-memory contents
0xF4	FLUSH	Flush Flash cache
0xF5	WRITE_MODE	Write nonvolatile BOOT mode value

STATUS code(s) returned in RESPONSE packet.

TABLE 8-2: COMMAND STATUS SUMMARY

CODE	NAME	DESCRIPTION
0x00	OK	No error
0x01	BAD_PACKET	Packet was malformed, unrecognized or timed out

8.2 Command: VERSION

Request firmware version packet – includes Boot mode.

COMMAND PACKET:

TABLE 8-3: COMMAND: VERSION

BYTE#	VALUE	DESCRIPTION
1	0x55	SYNC
2	0x01	SIZE
3	0x01	COMMAND

RESPONSE PACKET:

TABLE 8-4: RESPONSE: VERSION

BYTE#	VALUE	DESCRIPTION
1	0x55	SYNC
2	0x06	SIZE
3	STATUS	STATUS
4	0x01	COMMAND
6	VER_MAJOR	VERSION (Major)
7	VER_MINOR	VERSION (Minor)
8	VER_REV	VERSION (Revision – internal)
9	MODE	Boot mode 0: Normal 1: Write boot – upper Flash 2: Write application – lower 3: Write application – upper

8.3 Command: RESET

Execute a device Reset. If in USB mode, the device will detach from the bus and re-enumerate.

COMMAND PACKET:

TABLE 8-5: COMMAND: RESET

BYTE#	VALUE	DESCRIPTION
1	0x55	SYNC
2	0x01	SIZE
3	0xF0	COMMAND

RESPONSE PACKET:

None.

8.4 Command: INIT

Initialize the boot load process – executed as the first step after Reset.

COMMAND PACKET:

TABLE 8-6: COMMAND: INIT

BYTE#	VALUE	DESCRIPTION
1	0x55	SYNC
2	0x01	SIZE
3	0xF1	COMMAND

RESPONSE PACKET:

TABLE 8-7: RESPONSE: INIT

BYTE#	VALUE	DESCRIPTION
1	0x55	SYNC
2	2	SIZE
3	STATUS	STATUS
4	0xF1	COMMAND

8.5 Command: WRITE

The `WRITE` command facilitates programming Flash or EEPROM. The Most Significant Byte of the 24-bit address in the `WRITE` command dictates the destination. The AR1100 maps Flash to 0x000000 and EEPROM, to 0xF00000.

COMMAND PACKET:

TABLE 8-8: COMMAND: WRITE

BYTE#	VALUE	DESCRIPTION
1	0x55	SYNC
2	N+4	SIZE (N = # of data bytes to write)
3	0xF2	COMMAND
4	ADDR 07:00	ADDRESS
5	ADDR 15:08	
6	ADDR 23:16	
7	[DATA 1]	
...	...	
N+6	[DATA N]	

RESPONSE PACKET:

TABLE 8-9: RESPONSE: WRITE

BYTE#	VALUE	DESCRIPTION
1	0x55	SYNC
2	2	SIZE
3	STATUS	STATUS
4	0xF2	COMMAND (WRITE)

8.6 Command: READ

Read from device Flash or EEPROM.

REMINDER: Flash data will be encrypted while EEPROM data will not be encrypted.

COMMAND PACKET:

TABLE 8-10: COMMAND: READ

BYTE#	VALUE	DESCRIPTION
1	0x55	SYNC
2	0x05	SIZE
3	0xF3	COMMAND
4	ADDR 07:00	ADDRESS
5	ADDR 15:08	
6	ADDR 23:16	
7	N	# Bytes to Read

RESPONSE PACKET:

TABLE 8-11: RESPONSE: READ

BYTE#	VALUE	DESCRIPTION
1	0x55	SYNC
2	N+2	SIZE (N = # of data bytes to read)
3	STATUS	STATUS
4	0xF3	COMMAND
5	[DATA 1]	
6	...	
7	[DATA N]	

AR1100 RESISTIVE USB AND RS-232 TOUCH SCREEN CONTROLLER

8.7 Command: FLUSH

The FLUSH command is required to write/flush any data remaining in the internal cache at the end of a boot load session.

COMMAND PACKET:

TABLE 8-12: COMMAND: FLUSH

BYTE#	VALUE	DESCRIPTION
1	0x55	SYNC
2	0x01	SIZE
3	0xF4	COMMAND

RESPONSE PACKET:

TABLE 8-13: RESPONSE: FLUSH

BYTE#	VALUE	DESCRIPTION
1	0x55	SYNC
2	2	SIZE
3	STATUS	STATUS
4	0xF4	COMMAND

8.8 Command: WRITE_MODE

The WRITE_MODE command is used to change the operational mode of the bootloader. The four modes are described in Table 8-16.

COMMAND PACKET:

TABLE 8-14: COMMAND: WRITE_MODE

BYTE#	VALUE	DESCRIPTION
1	0x55	SYNC
2	0x05	SIZE
3	0xF5	COMMAND
4	n/a	
5	n/a	
6	n/a	
7	M	1_Byte mode Code

RESPONSE PACKET:

TABLE 8-15: RESPONSE: WRITE_MODE

BYTE#	VALUE	DESCRIPTION
1	0x55	SYNC
2	2	SIZE
3	STATUS	STATUS
4	0xF5	COMMAND

The boot load "MODE CODE" (referenced above) is a 1-byte value saved in nonvolatile memory to indicate boot status.

TABLE 8-16: WRITE_MODE CODES

Value	Description
0x00	Normal mode (application)
0x01	Programming/Flashing 'upper' application
0x02	Programming/Flashing 'lower' application
0x03	Programming/Flashing temporary 'boot' module

AR1100 RESISTIVE USB AND RS-232 TOUCH SCREEN CONTROLLER

9.0 EEPROM MAP

TABLE 9-1: EEPROM MAP

	ADDR(D)	ADDR(D)	Value	Description
USER	0	00	USER	User-defined area
		
	95	5F		
PARAMETERS	96	60	0x55	HEADER – PARAMETER BLOCK
	97	61	RisetimeCapTimeout	
	98	62	RisetimeQuick	
	99	63	TouchThreshold	
	100	64	SensitivityFilter	
	101	65	SamplingFast	
	102	66	SamplingSlow	
	103	67	AccuracyFilterFast	
	104	68	AccuracyFilterSlow	
	105	69	SpeedThreshold	
	106	6A	DitherFilter	
	107	6B	SleepDelay	
	108	6C	PenUpDelay	
	109	6D	TouchMode	
	110	6E	TouchOptions	
	111	6F	CalibrationInset	
	112	70	PenStateReportDelay	
	113	71	n/a	
	114	72	TouchReportDelay	
	115	73	RisetimeDefault	
116	74	RisetimeModifier		
117	75	Status		
118	76	Debug		
CALIBRATION	119	77	NOT USED	NOT USED
		
	127	7F		
	128	80	0x55	HEADER – CALIBRATION DATA BLOCK
	129	81	flags	bit flags
	130	82	nx	number of calibration point on X axis
	131	83	ny	number of calibration point on Y axis
	132	84	inset	inset
	133	85	type	calibration type
	134	86	nx_offset[0]	calculated 16-bit calibration point offset – xaxis
	135	87		
	136	88	nx_offset[1]	calculated 16-bit calibration point offset – xaxis
	137	89		
138	8A	nx_offset[2]	calculated 16-bit calibration point offset – xaxis	
139	8B			
140	8C	nx_offset[3]	calculated 16-bit calibration point offset – xaxis	

Note 1: Locations 0xFE, 0xFF are off-limits and should not be overwritten.

AR1100 RESISTIVE USB AND RS-232 TOUCH SCREEN CONTROLLER

TABLE 9-1: EEPROM MAP (CONTINUED)

	ADDR(D)	ADDR(D)	Value	Description
	141	8D		
	142	8E	nx_offset[4]	calculated 16-bit calibration point offset – xaxis
	143	8F		
	144	90	ny_offset[0]	calculated 16-bit calibration point offset – yaxis
	145	91		
	146	92	ny_offset[1]	calculated 16-bit calibration point offset – yaxis
	147	93		
	148	94	ny_offset[2]	calculated 16-bit calibration point offset – yaxis
	149	95		
	150	96	ny_offset[3]	calculated 16-bit calibration point offset – yaxis
	151	97		
	152	98	ny_offset[4]	calculated 16-bit calibration point offset – yaxis
	153	99		
	154	9A	xy [0,0]	calibration point 0, X ordinate (16 bit)
	155	9B		
	156	9C	xy [1,0]	calibration point 0, Y ordinate (16 bit)
	157	9D		
	158	9E	xy [0,1]	calibration point 1, X ordinate (16 bit)
	159	9F		
	160	A0	xy [1,1]	calibration point 1, Y ordinate (16 bit)
	161	A1		
	162	A2	...	calibration point(s)
		
	249	F9		
	250	FA	xy [24,1]	calibration point 24, X ordinate (16 bit)
	251	FB		
	252	FC	xy [24,1]	calibration point 24, Y ordinate (16 bit)
	253	FD		
	254	FE	usb_mode	USB MODE (GENERIC, MOUSE, DIGITIZER)
	255	FF	boot_mode	BOOT MODE (0 = NORMAL/NON-BOOT)

Note 1: Locations 0xFE, 0xFF are off-limits and should not be overwritten.

10.0 ELECTRICAL SPECIFICATIONS

Absolute Maximum Ratings^(†)

Ambient temperature under bias	-40°C to +85°C
Storage temperature	-65°C to +150°C
Voltage on VDD with respect to VSS	-0.3V to +6.5V
Voltage on all other pins with respect to VSS	-0.3V to (VDD + 0.3V)
Total power dissipation	800 mW
Maximum current out of VSS pin	300 mA
Maximum current into VDD pin	250 mA
Input clamp current ($V_I < 0$ or $V_I > V_{DD}$)	± 20 mA
Maximum output current sunk by any I/O pin	25 mA
Maximum output current sourced by any I/O pin	25 mA

† NOTICE: Stresses above those listed under “Absolute Maximum Ratings” may cause permanent damage to the device. This is a stress rating only and functional operation of the device at those or any other conditions above those indicated in the operation listings of this specification is not implied. Exposure above maximum rating conditions for extended periods may affect device reliability.

† NOTICE: This device is sensitive to ESD damage and must be handled appropriately. Failure to properly handle and protect the device in an application may cause partial to complete failure of the device.

AR1100 RESISTIVE USB AND RS-232 TOUCH SCREEN CONTROLLER

NOTES:

AR1100 RESISTIVE USB AND RS-232 TOUCH SCREEN CONTROLLER

11.0 PACKAGING INFORMATION

11.1 Package Marking Information

20-Lead SSOP (5.30 mm)

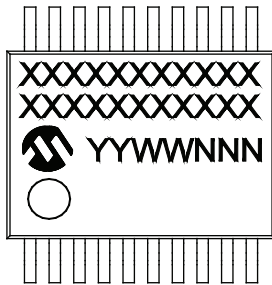

20-Lead SOIC (7.50 mm)

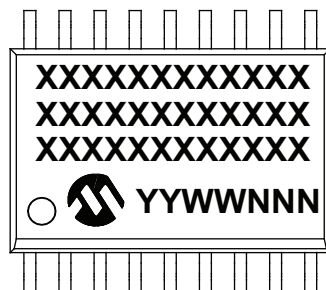

20-Lead QFN (5x5x0.9 mm)

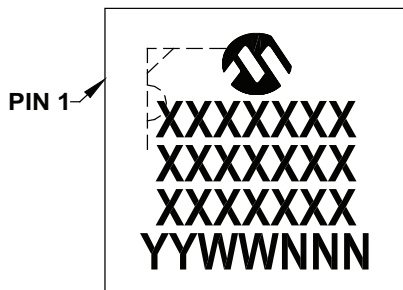

Example

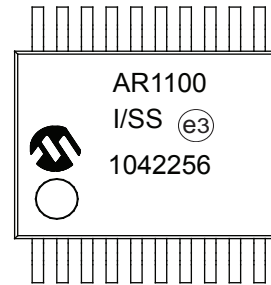

Example

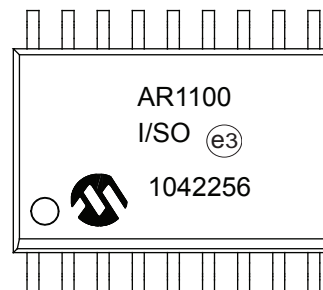

Example

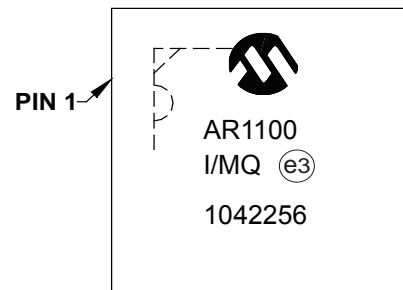

Legend:	XX...X	Customer-specific information
	Y	Year code (last digit of calendar year)
	YY	Year code (last 2 digits of calendar year)
	WW	Week code (week of January 1 is week '01')
	NNN	Alphanumeric traceability code
	(e3)	Pb-free JEDEC designator for Matte Tin (Sn)
	*	This package is Pb-free. The Pb-free JEDEC designator (e3) can be found on the outer packaging for this package.

Note: In the event the full Microchip part number cannot be marked on one line, it will be carried over to the next line, thus limiting the number of available characters for customer-specific information.

* Standard PICmicro® device marking consists of Microchip part number, year code, week code and traceability code. For PICmicro device marking beyond this, certain price adders apply. Please check with your Microchip Sales Office. For QTP devices, any special marking adders are included in QTP price.

AR1100 RESISTIVE USB AND RS-232 TOUCH SCREEN CONTROLLER

11.2 Ordering

TABLE 11-1: ORDERING PART NUMBERS

Part Number	Temperature Range	Package	Packing
AR1100-I/SS	-40°C to +85°C	SSOP, 20 pins	Tube
AR1100T-I/SS	-40°C to +85°C	SSOP, 20 pins	T/R
AR1100-I/SO	-40°C to +85°C	SOIC, 20 pins	Tube
AR1100T-I/SO	-40°C to +85°C	SOIC, 20 pins	T/R
AR1100-I/MQ	-40°C to +85°C	QFN, 20 pins	Tube
AR1100T-I/MQ	-40°C to +85°C	QFN, 20 pins	T/R

AR1100 RESISTIVE USB AND RS-232 TOUCH SCREEN CONTROLLER

11.3 Package Details

The following sections give the technical details of the packages.

20-Lead Plastic Shrink Small Outline (SS) – 5.30 mm Body [SSOP]

Note: For the most current package drawings, please see the Microchip Packaging Specification located at <http://www.microchip.com/packaging>

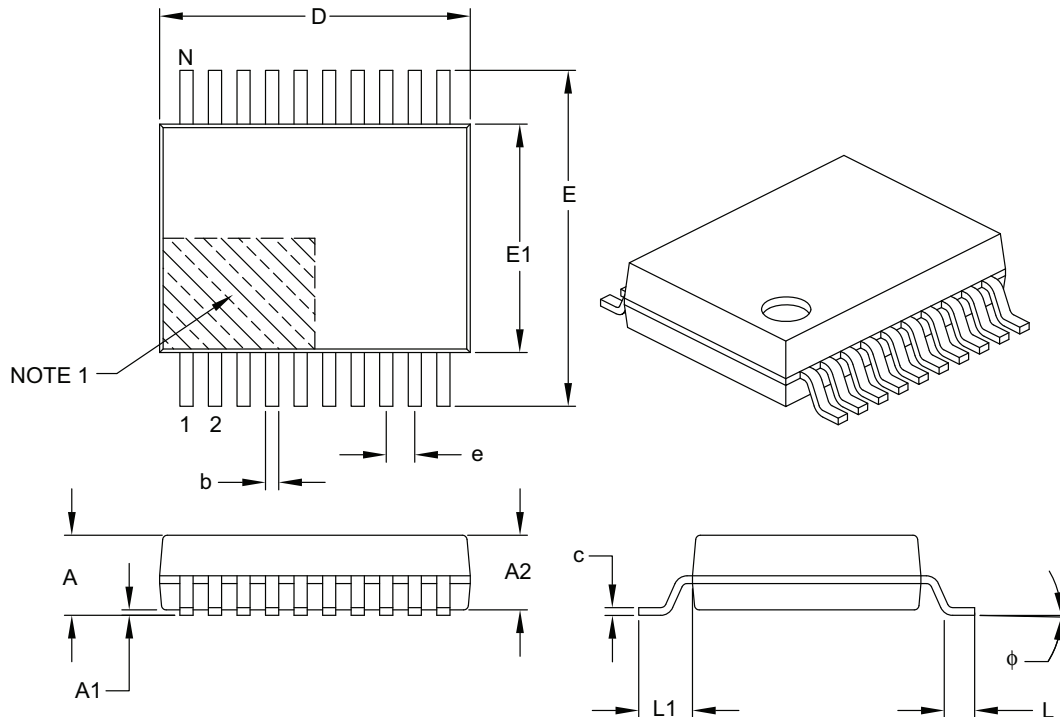

Dimension Limits	Units	MILLIMETERS		
		MIN	NOM	MAX
Number of Pins	N	20		
Pitch	e	0.65 BSC		
Overall Height	A	–	–	2.00
Molded Package Thickness	A2	1.65	1.75	1.85
Standoff	A1	0.05	–	–
Overall Width	E	7.40	7.80	8.20
Molded Package Width	E1	5.00	5.30	5.60
Overall Length	D	6.90	7.20	7.50
Foot Length	L	0.55	0.75	0.95
Footprint	L1	1.25 REF		
Lead Thickness	c	0.09	–	0.25
Foot Angle	ϕ	0°	4°	8°
Lead Width	b	0.22	–	0.38

Notes:

- Pin 1 visual index feature may vary, but must be located within the hatched area.
- Dimensions D and E1 do not include mold flash or protrusions. Mold flash or protrusions shall not exceed 0.20 mm per side.
- Dimensioning and tolerancing per ASME Y14.5M.

BSC: Basic Dimension. Theoretically exact value shown without tolerances.

REF: Reference Dimension, usually without tolerance, for information purposes only.

Microchip Technology Drawing C04-072B

AR1100 RESISTIVE USB AND RS-232 TOUCH SCREEN CONTROLLER

20-Lead Plastic Shrink Small Outline (SS) - 5.30 mm Body [SSOP]

Note: For the most current package drawings, please see the Microchip Packaging Specification located at <http://www.microchip.com/packaging>

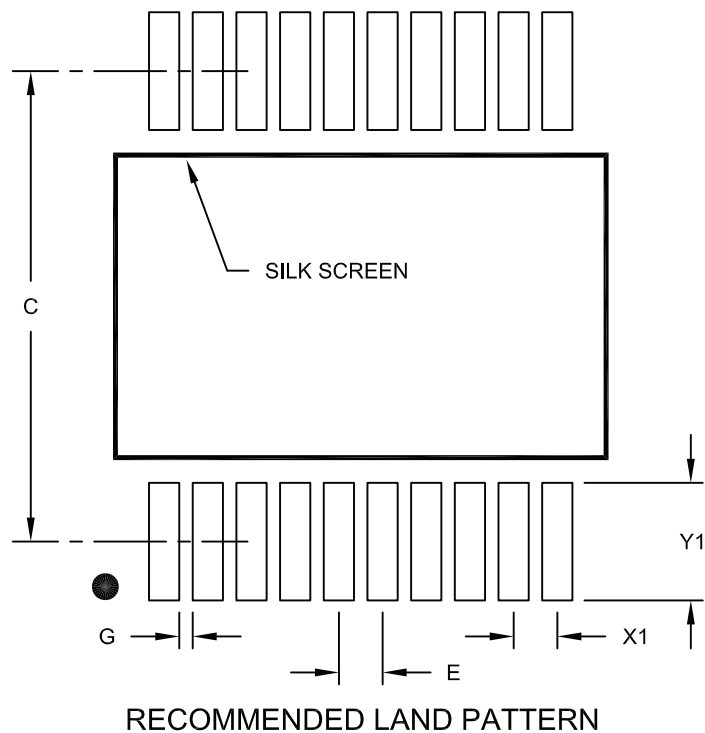

Dimension Limits	Units	MILLIMETERS		
		MIN	NOM	MAX
Contact Pitch	E	0.65 BSC		
Contact Pad Spacing	C		7.20	
Contact Pad Width (X20)	X1			0.45
Contact Pad Length (X20)	Y1			1.75
Distance Between Pads	G	0.20		

Notes:

1. Dimensioning and tolerancing per ASME Y14.5M

BSC: Basic Dimension. Theoretically exact value shown without tolerances.

Microchip Technology Drawing No. C04-2072A

AR1100 RESISTIVE USB AND RS-232 TOUCH SCREEN CONTROLLER

20-Lead Plastic Small Outline (SO) - Wide, 7.50 mm Body [SOIC]

Note: For the most current package drawings, please see the Microchip Packaging Specification located at <http://www.microchip.com/packaging>

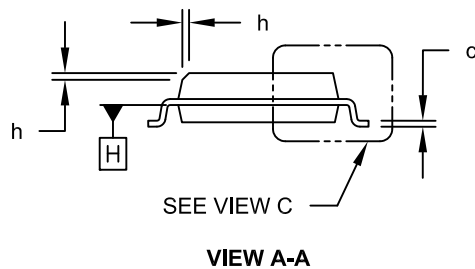
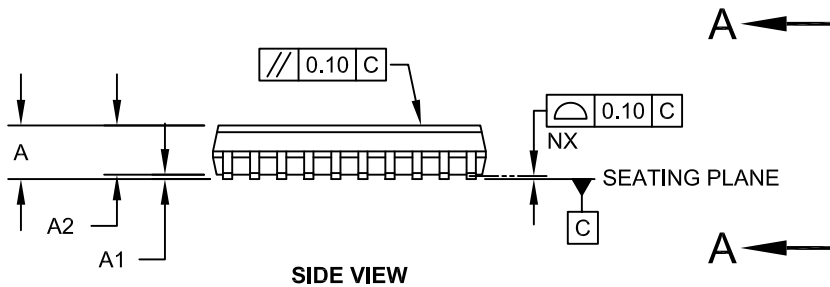
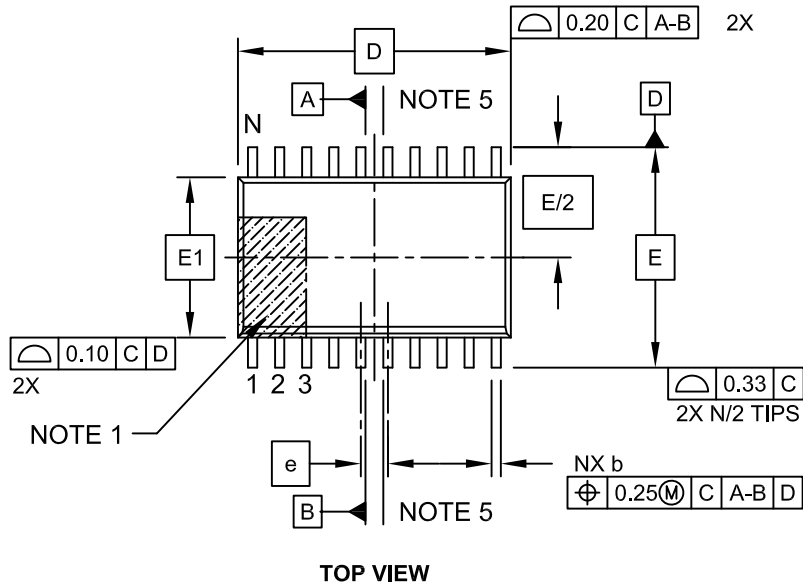

Microchip Technology Drawing C04-094C Sheet 1 of 2

AR1100 RESISTIVE USB AND RS-232 TOUCH SCREEN CONTROLLER

20-Lead Plastic Small Outline (SO) - Wide, 7.50 mm Body [SOIC]

Note: For the most current package drawings, please see the Microchip Packaging Specification located at <http://www.microchip.com/packaging>

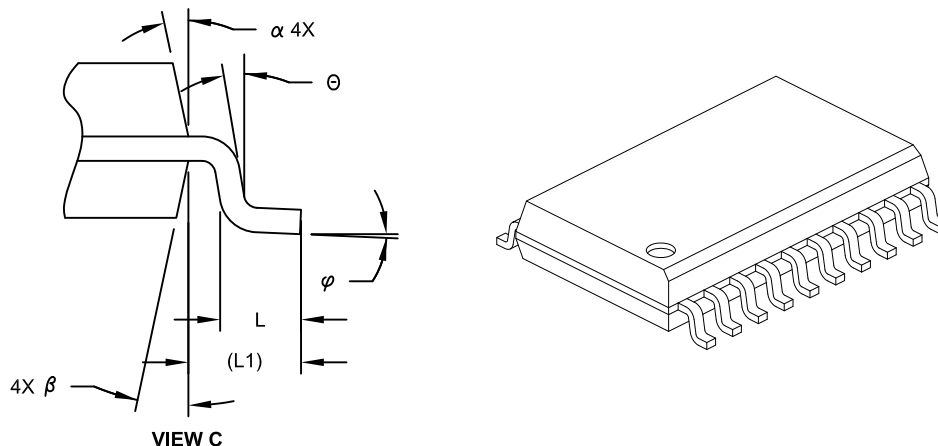

Dimension Limits	Units	MILLIMETERS		
		MIN	NOM	MAX
Number of Pins	N	20		
Pitch	e	1.27 BSC		
Overall Height	A	-	-	2.65
Molded Package Thickness	A2	2.05	-	-
Standoff §	A1	0.10	-	0.30
Overall Width	E	10.30 BSC		
Molded Package Width	E1	7.50 BSC		
Overall Length	D	12.80 BSC		
Chamfer (Optional)	h	0.25	-	0.75
Foot Length	L	0.40	-	1.27
Footprint	L1	1.40 REF		
Lead Angle	Θ	0°	-	-
Foot Angle	φ	0°	-	8°
Lead Thickness	c	0.20	-	0.33
Lead Width	b	0.31	-	0.51
Mold Draft Angle Top	α	5°	-	15°
Mold Draft Angle Bottom	β	5°	-	15°

Notes:

- Pin 1 visual index feature may vary, but must be located within the hatched area.
- § Significant Characteristic
- Dimension D does not include mold flash, protrusions or gate burrs, which shall not exceed 0.15 mm per end. Dimension E1 does not include interlead flash or protrusion, which shall not exceed 0.25 mm per side.
- Dimensioning and tolerancing per ASME Y14.5M
 BSC: Basic Dimension. Theoretically exact value shown without tolerances.
 REF: Reference Dimension, usually without tolerance, for information purposes only.
- Datums A & B to be determined at Datum H.

Microchip Technology Drawing No. C04-094C Sheet 2 of 2

AR1100 RESISTIVE USB AND RS-232 TOUCH SCREEN CONTROLLER

20-Lead Plastic Small Outline (SO) - Wide, 7.50 mm Body [SOIC]

Note: For the most current package drawings, please see the Microchip Packaging Specification located at <http://www.microchip.com/packaging>

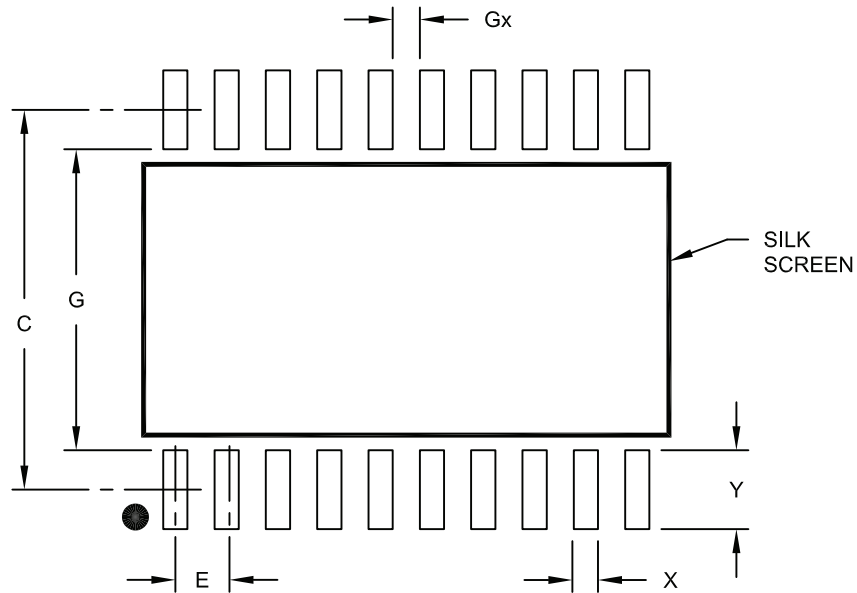

RECOMMENDED LAND PATTERN

Dimension Limits	Units	MILLIMETERS		
		MIN	NOM	MAX
Contact Pitch	E	1.27 BSC		
Contact Pad Spacing	C	9.40		
Contact Pad Width (X20)	X			0.60
Contact Pad Length (X20)	Y			1.95
Distance Between Pads	Gx	0.67		
Distance Between Pads	G	7.45		

Notes:

1. Dimensioning and tolerancing per ASME Y14.5M

BSC: Basic Dimension. Theoretically exact value shown without tolerances.

Microchip Technology Drawing No. C04-2094A

AR1100 RESISTIVE USB AND RS-232 TOUCH SCREEN CONTROLLER

20-Lead Plastic Quad Flat, No Lead Package (MQ) – 5x5x0.9 mm Body [QFN]

Note: For the most current package drawings, please see the Microchip Packaging Specification located at <http://www.microchip.com/packaging>

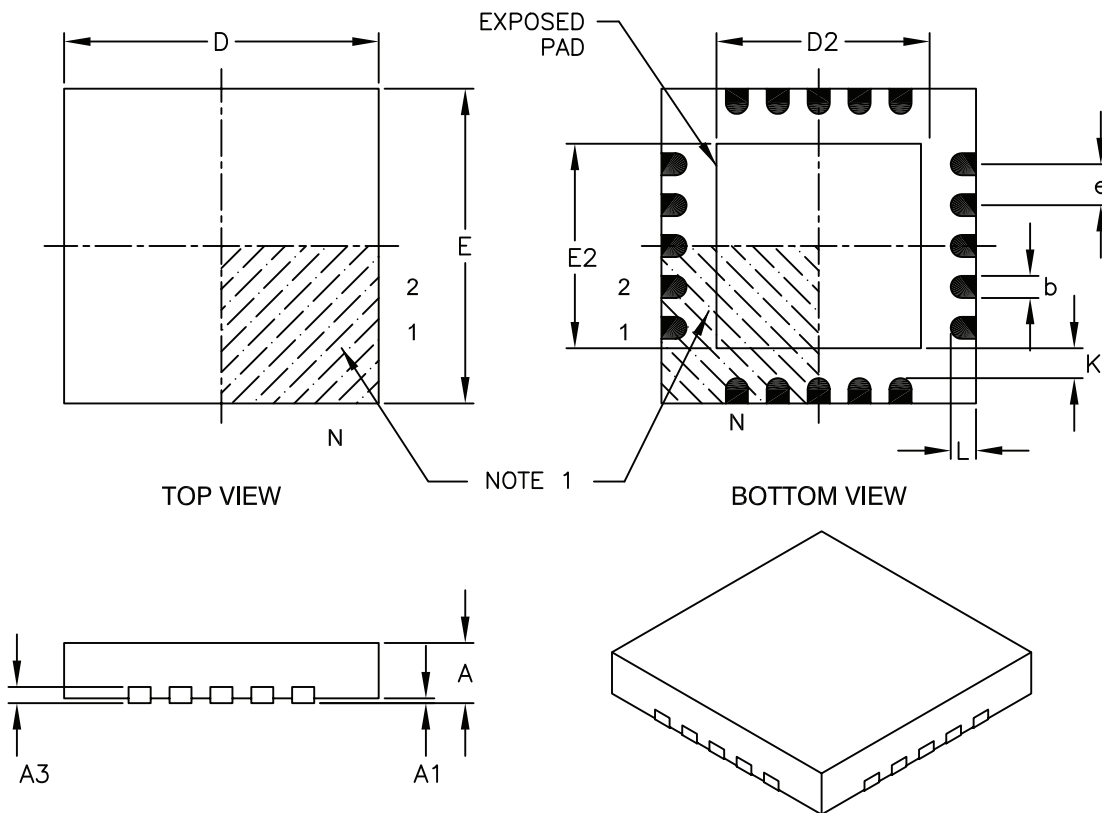

Dimension Limits	Units	MILLIMETERS		
		MIN	NOM	MAX
Number of Pins	N	20		
Pitch	e	0.65 BSC		
Overall Height	A	0.80	0.90	1.00
Standoff	A1	0.00	0.02	0.05
Contact Thickness	A3	0.20 REF		
Overall Width	E	5.00 BSC		
Exposed Pad Width	E2	3.15	3.25	3.35
Overall Length	D	5.00 BSC		
Exposed Pad Length	D2	3.15	3.25	3.35
Contact Width	b	0.25	0.30	0.35
Contact Length	L	0.35	0.40	0.45
Contact-to-Exposed Pad	K	0.20	-	-

Notes:

- Pin 1 visual index feature may vary, but must be located within the hatched area.
- Package is saw singulated.
- Dimensioning and tolerancing per ASME Y14.5M.

BSC: Basic Dimension. Theoretically exact value shown without tolerances.

REF: Reference Dimension, usually without tolerance, for information purposes only.

Microchip Technology Drawing C04-139B

AR1100 RESISTIVE USB AND RS-232 TOUCH SCREEN CONTROLLER

20-Lead Plastic Quad Flat, No Lead Package (MQ) - 5x5 mm Body [QFN]
With 0.40mm Contact Length

Note: For the most current package drawings, please see the Microchip Packaging Specification located at <http://www.microchip.com/packaging>

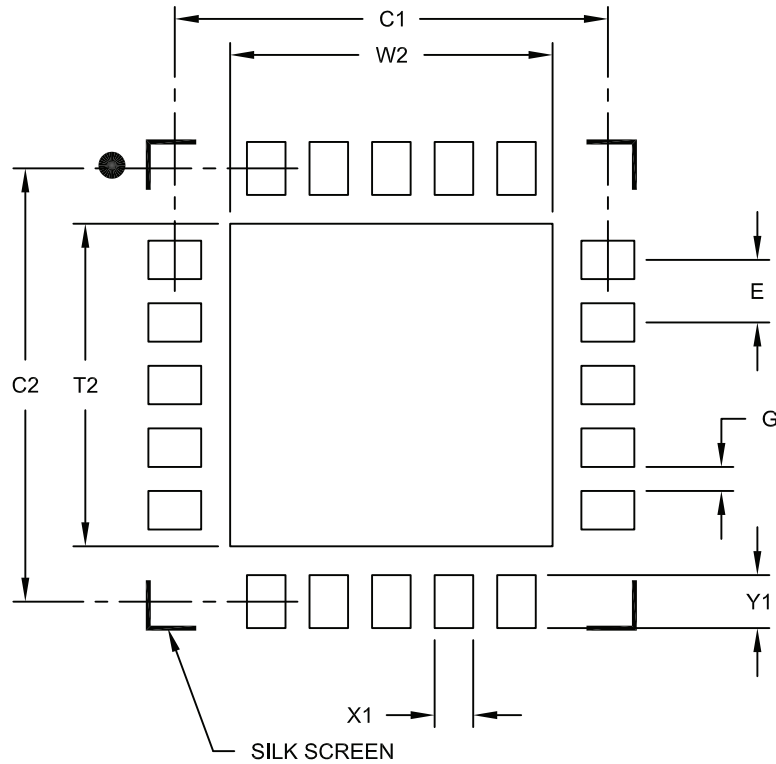

RECOMMENDED LAND PATTERN

Dimension Limits	Units	MILLIMETERS		
		MIN	NOM	MAX
Contact Pitch	E	0.65 BSC		
Optional Center Pad Width	W2			3.35
Optional Center Pad Length	T2			3.35
Contact Pad Spacing	C1		4.50	
Contact Pad Spacing	C2		4.50	
Contact Pad Width (X20)	X1			0.40
Contact Pad Length (X20)	Y1			0.55
Distance Between Pads	G	0.20		

Notes:

1. Dimensioning and tolerancing per ASME Y14.5M

BSC: Basic Dimension. Theoretically exact value shown without tolerances.

Microchip Technology Drawing No. C04-2139A

AR1100 RESISTIVE USB AND RS-232 TOUCH SCREEN CONTROLLER

NOTES:

APPENDIX A: DATA SHEET REVISION HISTORY

Revision A (08/2011)

Original release of this data sheet.

Revision B (11/2011)

Updated schematic.

AR1100 RESISTIVE USB AND RS-232 TOUCH SCREEN CONTROLLER

APPENDIX B:

FIGURE B-1: SCHEMATIC

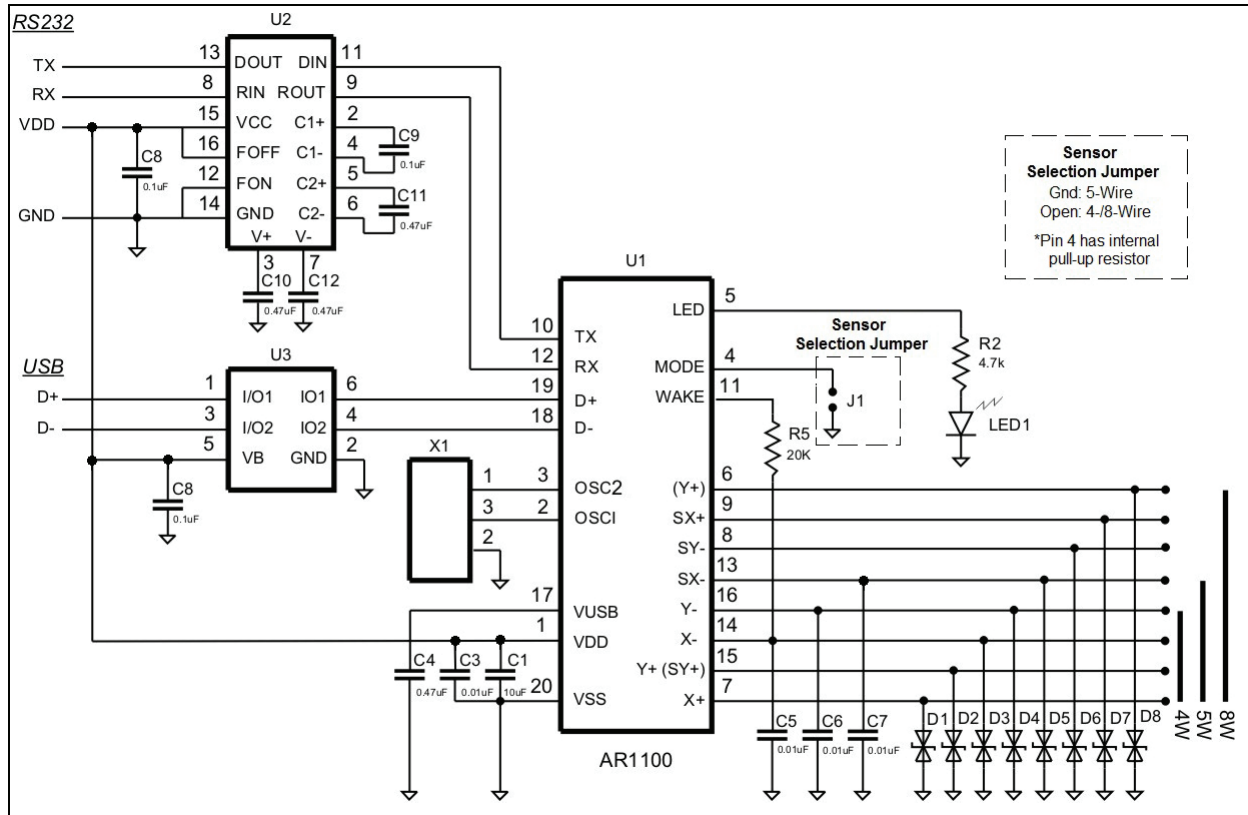

FIGURE B-2: BILL OF MATERIALS

Microchip Technology.

Bill of Materials / Assembly: 02-02230-R3
 Project: AR1100
 PCB Artwork: 04-02230-R3
 Date: 2010-12-27

All parts must be RoHS compliant.

Designator	Quantity	Value	Description	Manufacturer	OEM Part Number	Source	Distributor Part Number
C1	1	10 uF	CAP CER 10UF 6.3V XSR 0603	Murata Electronics	GRM188R60J106ME47D	Digi-key	490-3896-2-ND
C2, C3, C8, C9	4	0.1 uF	CAP CER, 1UF 25V 10% X7R 0603	Murata Electronics	GRM188R71E104KA01D	Digi-key	490-1524-2-ND
C4, C10, C11, C12	4	0.47 uF	CAP CER, 47UF 16V X7R 0603	Murata Electronics	GRM188R71C474KA88D	Digi-key	490-3295-2-ND
C5, C6, C7	3	0.01 uF	CAP CER 10000PF 50V 10% X7R 0603	Murata Electronics	GRM188R71H103KA01D	Digi-key	490-1512-2-ND
D1, D2, D3, D4, D5, D6, D7, D8	8		DIODE BIDIR ESD PROTECT SOD323	NXP Semiconductors	PESD5V0S1BA, 115	Digi-key	568-4053-2-ND
J1	1		CONN HEADER 2MM SINGLE STR 2POS	Sullins	NRPN021PAEN-RC	Digi-key	55800-02-ND
LED1	1		LED GREEN CLEAR THIN 0603 SMD	Lite-On Inc	LTST-C191GKT	Digi-key	160-1443-2-ND
R1, R5	2	20K ohm	RES 20K OHM 1/10W 5% 0603 SMD	Yageo	RC0603JR-0720KL	Digi-key	311-20KGRTR-ND
R2	1	4.7K ohm	RES 4.7K OHM 1/10W 5% 0603 SMD	Yageo	RC0603JR-074K7L	Digi-key	311-4.7KGRTR-ND
U1	1		IC PIC MCU FLASH 8KX16 20-SSOP	Microchip	AR1100-VSS	Microchip Direct	AR1100-VSS
U2	1		IC RS232 3V-5.5V DRV R 16-SSOP	Texas Instruments	MAX3227EIDBR	Digi-key	296-19829-2-ND
U3	1		IC ESD PROTECTION LO CAP SOT23-6	STMicroelectronics	USBLC6-2SC6	Digi-key	497-5235-2-ND
X1	1		CER RESONATOR 12.0MHZ SMD	Murata Electronics	CSTCE12M0G55Z-R0	Digi-key	490-1220-2-ND

Note: ESD protection diodes are recommended for all active sensor lines but care should be taken to minimize capacitance. As an example, PESD5V0S1BA is recommended and used on reference designs due to its nominally-low 35 pF.

Note: Unused SENSOR pins should be grounded.

AR1100 RESISTIVE USB AND RS-232 TOUCH SCREEN CONTROLLER

INDEX

A

Absolute Maximum Ratings 39

B

Boot Loader 33

C

Calibration 29

COMMAND

CALIBRATE 22

EE_READ 23

EE_READ_PARAMS 24

EE_WRITE 23

EE_WRITE_PARAMS 24

REG_READ 22

REG_WRITE 23

USB_MODE_DIGITIZER 24

USB_MODE_GENERIC 24

USB_MODE_MOUSE 24

Command

FLUSH 36

INIT 35

READ 35

RESET 34

TOUCH_DISABLE 22

TOUCH_ENABLE 22

VERSION 34

WRITE 35

WRITE_MODE 36

Command Packets 17

Command Summary 34

Commands 21

Communication 3, 13

Configuration 29

Configuration Registers 25

Configure Sensor Type 31

Customer Change Notification Service 55

Customer Notification Service 55

Customer Support 55

D

Data Protocol 14

Device Overview 5

E

EEPROM Map 37

Electrical Specifications 39

Errata 4

ESD Considerations 11

H

Hardware 9

I

Implementation - Quick Start 7

Internet Address 55

L

LED 31

M

Microchip Internet Web Site 55

Migrating from other PIC Microcontroller Devices 52

Mode

HID-DIGITIZER 17

HID-MOUSE 14

UART, HID-GENERIC 14

Mode Detect/Select 13

N

Noise Considerations 11

O

Operation 29

Overview 5

P

Packaging 41

Marking 41

PDIP Details 43

Physical 13

Power Requirements 3

R

Reader Response 56

Revision History 51

S

Schematic 9

Sensor Attachment 10

Sleep 31

Special Features 3

T

Touch Modes 3

Touch Reports 14

Touch Resolution 3

Touch Sensor Support 3

U

UART Mode 13

USB Mode 14

USB Mode Change 31

W

WWW Address 55

WWW, On-Line Support 4

AR1100 RESISTIVE USB AND RS-232 TOUCH SCREEN CONTROLLER

NOTES:

THE MICROCHIP WEB SITE

Microchip provides online support via our WWW site at www.microchip.com. This web site is used as a means to make files and information easily available to customers. Accessible by using your favorite Internet browser, the web site contains the following information:

- **Product Support** – Data sheets and errata, application notes and sample programs, design resources, user's guides and hardware support documents, latest software releases and archived software
- **General Technical Support** – Frequently Asked Questions (FAQ), technical support requests, online discussion groups, Microchip consultant program member listing
- **Business of Microchip** – Product selector and ordering guides, latest Microchip press releases, listing of seminars and events, listings of Microchip sales offices, distributors and factory representatives

CUSTOMER CHANGE NOTIFICATION SERVICE

Microchip's customer notification service helps keep customers current on Microchip products. Subscribers will receive e-mail notification whenever there are changes, updates, revisions or errata related to a specified product family or development tool of interest.

To register, access the Microchip web site at www.microchip.com. Under "Support", click on "Customer Change Notification" and follow the registration instructions.

CUSTOMER SUPPORT

Users of Microchip products can receive assistance through several channels:

- Distributor or Representative
- Local Sales Office
- Field Application Engineer (FAE)
- Technical Support
- Development Systems Information Line

Customers should contact their distributor, representative or field application engineer (FAE) for support. Local sales offices are also available to help customers. A listing of sales offices and locations is included in the back of this document.

Technical support is available through the web site at: <http://microchip.com/support>

AR1100 RESISTIVE USB AND RS-232 TOUCH SCREEN CONTROLLER

READER RESPONSE

It is our intention to provide you with the best documentation possible to ensure successful use of your Microchip product. If you wish to provide your comments on organization, clarity, subject matter, and ways in which our documentation can better serve you, please FAX your comments to the Technical Publications Manager at (480) 792-4150.

Please list the following information, and use this outline to provide us with your comments about this document.

TO: Technical Publications Manager Total Pages Sent _____

RE: Reader Response

From: Name _____

Company _____

Address _____

City / State / ZIP / Country _____

Telephone: (_____) _____ - _____ FAX: (_____) _____ - _____

Application (optional):

Would you like a reply? Y N

Device: AR1100 Resistive USB and RS-232 Touch Screen Controller Literature Number: DS41606B

Questions:

1. What are the best features of this document?

2. How does this document meet your hardware and software development needs?

3. Do you find the organization of this document easy to follow? If not, why?

4. What additions to the document do you think would enhance the structure and subject?

5. What deletions from the document could be made without affecting the overall usefulness?

6. Is there any incorrect or misleading information (what and where)?

7. How would you improve this document?

AR1100 RESISTIVE USB AND RS-232 TOUCH SCREEN CONTROLLER

PRODUCT IDENTIFICATION SYSTEM

To order or obtain information, e.g., on pricing or delivery, refer to the factory or the listed sales office.

<u>PART NO.</u>	<u>[X]⁽¹⁾</u>	-	<u>X</u>	<u>/XX</u>	<u>XXX</u>
Device	Tape and Reel Option		Temperature Range	Package	Pattern
Device:	AR1100:		Resistive USB and RS-232 Touch Screen Controller		
	AR1100T:		Resistive USB and RS-232 Touch Screen Controller (Tape and Reel)		
Temperature Range:	I	=	-40°C to +85°C (Industrial)		
Package:	MQ	=	Plastic Quad Flat, No Lead Package 5x5x0.09 mm Body (QFN), 20-Lead		
	SO	=	Plastic Small Outline - Wide, 7.50 mm Body (SO), 20-Lead		
	SS	=	Plastic Shrink Small Outline - 5.30 mm Body (SS), 20-Lead		

Examples:

- a) AR1100 - I/MQ: Industrial temperature, 20LD QFN Package.
- b) AR1100T - I/MQ: Tape and Reel, Industrial temperature, 20LD QFN Package
- c) AR1100 - I/SO: Industrial temperature, 20LD SOIC Package.
- d) AR1100T - I/SO: Tape and Reel, Industrial temperature, 20LD SOIC Package
- e) AR1100 - I/SS: Industrial temperature, 20LD SSOP Package
- f) AR1100T - I/SS: Tape and Reel, Industrial temperature, 20LD SSOP Package



MICROCHIP

Worldwide Sales and Service

AMERICAS

Corporate Office
2355 West Chandler Blvd.
Chandler, AZ 85224-6199
Tel: 480-792-7200
Fax: 480-792-7277
Technical Support:
<http://www.microchip.com/support>
Web Address:
www.microchip.com

Atlanta
Duluth, GA
Tel: 678-957-9614
Fax: 678-957-1455

Boston
Westborough, MA
Tel: 774-760-0087
Fax: 774-760-0088

Chicago
Itasca, IL
Tel: 630-285-0071
Fax: 630-285-0075

Cleveland
Independence, OH
Tel: 216-447-0464
Fax: 216-447-0643

Dallas
Addison, TX
Tel: 972-818-7423
Fax: 972-818-2924

Detroit
Farmington Hills, MI
Tel: 248-538-2250
Fax: 248-538-2260

Indianapolis
Noblesville, IN
Tel: 317-773-8323
Fax: 317-773-5453

Los Angeles
Mission Viejo, CA
Tel: 949-462-9523
Fax: 949-462-9608

Santa Clara
Santa Clara, CA
Tel: 408-961-6444
Fax: 408-961-6445

Toronto
Mississauga, Ontario,
Canada
Tel: 905-673-0699
Fax: 905-673-6509

ASIA/PACIFIC

Asia Pacific Office
Suites 3707-14, 37th Floor
Tower 6, The Gateway
Harbour City, Kowloon
Hong Kong
Tel: 852-2401-1200
Fax: 852-2401-3431

Australia - Sydney
Tel: 61-2-9868-6733
Fax: 61-2-9868-6755

China - Beijing
Tel: 86-10-8569-7000
Fax: 86-10-8528-2104

China - Chengdu
Tel: 86-28-8665-5511
Fax: 86-28-8665-7889

China - Chongqing
Tel: 86-23-8980-9588
Fax: 86-23-8980-9500

China - Hangzhou
Tel: 86-571-2819-3187
Fax: 86-571-2819-3189

China - Hong Kong SAR
Tel: 852-2401-1200
Fax: 852-2401-3431

China - Nanjing
Tel: 86-25-8473-2460
Fax: 86-25-8473-2470

China - Qingdao
Tel: 86-532-8502-7355
Fax: 86-532-8502-7205

China - Shanghai
Tel: 86-21-5407-5533
Fax: 86-21-5407-5066

China - Shenyang
Tel: 86-24-2334-2829
Fax: 86-24-2334-2393

China - Shenzhen
Tel: 86-755-8203-2660
Fax: 86-755-8203-1760

China - Wuhan
Tel: 86-27-5980-5300
Fax: 86-27-5980-5118

China - Xian
Tel: 86-29-8833-7252
Fax: 86-29-8833-7256

China - Xiamen
Tel: 86-592-2388138
Fax: 86-592-2388130

China - Zhuhai
Tel: 86-756-3210040
Fax: 86-756-3210049

ASIA/PACIFIC

India - Bangalore
Tel: 91-80-3090-4444
Fax: 91-80-3090-4123

India - New Delhi
Tel: 91-11-4160-8631
Fax: 91-11-4160-8632

India - Pune
Tel: 91-20-2566-1512
Fax: 91-20-2566-1513

Japan - Yokohama
Tel: 81-45-471- 6166
Fax: 81-45-471-6122

Korea - Daegu
Tel: 82-53-744-4301
Fax: 82-53-744-4302

Korea - Seoul
Tel: 82-2-554-7200
Fax: 82-2-558-5932 or
82-2-558-5934

Malaysia - Kuala Lumpur
Tel: 60-3-6201-9857
Fax: 60-3-6201-9859

Malaysia - Penang
Tel: 60-4-227-8870
Fax: 60-4-227-4068

Philippines - Manila
Tel: 63-2-634-9065
Fax: 63-2-634-9069

Singapore
Tel: 65-6334-8870
Fax: 65-6334-8850

Taiwan - Hsin Chu
Tel: 886-3-5778-366
Fax: 886-3-5770-955

Taiwan - Kaohsiung
Tel: 886-7-536-4818
Fax: 886-7-330-9305

Taiwan - Taipei
Tel: 886-2-2500-6610
Fax: 886-2-2508-0102

Thailand - Bangkok
Tel: 66-2-694-1351
Fax: 66-2-694-1350

EUROPE

Austria - Wels
Tel: 43-7242-2244-39
Fax: 43-7242-2244-393

Denmark - Copenhagen
Tel: 45-4450-2828
Fax: 45-4485-2829

France - Paris
Tel: 33-1-69-53-63-20
Fax: 33-1-69-30-90-79

Germany - Munich
Tel: 49-89-627-144-0
Fax: 49-89-627-144-44

Italy - Milan
Tel: 39-0331-742611
Fax: 39-0331-466781

Netherlands - Drunen
Tel: 31-416-690399
Fax: 31-416-690340

Spain - Madrid
Tel: 34-91-708-08-90
Fax: 34-91-708-08-91

UK - Wokingham
Tel: 44-118-921-5869
Fax: 44-118-921-5820

08/02/11

Looking for pricing, stock, or lifecycle information?

Click below to explore more details on WIN SOURCE:

- ⊖ [View AR1100-I/SS on WIN SOURCE](#)
- ⊖ [Microchip Technology](#) Information

Optimize Your Supply Chain with WIN SOURCE Solutions

- ✓ Global Sourcing Solution
- ✓ Obsolete Management
- ✓ Cost Control Management
- ✓ Shortage Management
- ✓ Alternative Solution
- ✓ Excess Inventory Management