



THE DATASHEET OF ALD2301ASAL



DUAL PRECISION CMOS VOLTAGE COMPARATOR WITH OPEN DRAIN DRIVER

GENERAL DESCRIPTION

The ALD2301A/ALD2301B/ALD2301C/ALD2301 is a monolithic high performance dual voltage comparator built with advanced silicon gate CMOS technology. It features very high typical input impedance of $10^{12}\Omega$; low input bias current of 10pA; fast response time of 300ns; very low power dissipation of 55µA per comparator; and single (+5V) or dual ($\pm 5V$) power supply operation.

The input voltage range includes ground, making this comparator ideal for low level signal detection with high source impedance. The outputs are open-drain configuration, allowing maximum application flexibility, such as wired-OR connection. The outputs can be connected to a higher external voltage than V+.

The ALD2301A/ALD2301B/ALD2301C/ALD2301 is ideal for a great variety of voltage comparator applications, especially low level signal detection circuits requiring low standby power, yet retaining high output current capability as needed.

APPLICATIONS

- High source impedance voltage comparison circuits
- Dual limit window comparator
- Power supply voltage monitor
- Photo-detector sensor circuit
- Relay or LED driver
- Oscillators
- Battery operated instruments
- Remote signal detection

BENEFITS

- Low power and high precision combination
- Built-in high input impedance buffer
- Built-in output driver with up to 60mA sink current

FEATURES

- Fanout of 30LS TTL loads
- Low supply current of 110µA typical
- Functional equivalent to LM193 industry standard comparators
- Extremely low input bias currents -- typically 10pA
- Virtually eliminates source impedance effects
- Low operating supply voltage of 3V to 10V
- Single (+5V) and dual supply ($\pm 5V$) operation
- High speed for both large signal and low level signals -- 300ns typical for TTL inputs
- CMOS, NMOS and TTL compatible
- Wired-OR open drain outputs
- High output sinking current -- typically 60mA
- Low supply current spikes

PIN CONFIGURATION

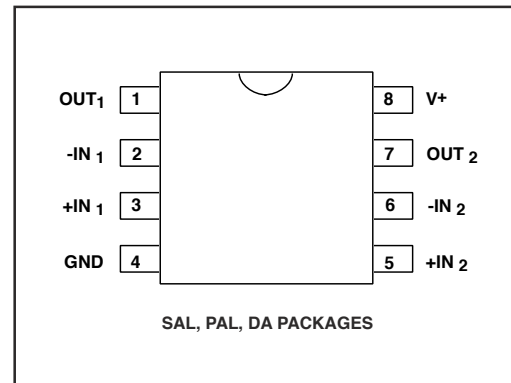

ORDERING INFORMATION ("L" suffix for lead free version)

Operating Temperature Range *		
0°C to +70°C	0°C to +70°C	-55°C to +125°C
8-Pin Small Outline Package (SOIC)	8-Pin Plastic Dip Package	8-Pin CERDIP Package
ALD2301ASAL	ALD2301APAL	ALD2301ADA
ALD2301BSAL	ALD2301BPAL	ALD2301BDA
ALD2301CSAL	ALD2301CPAL	ALD2301CDA
ALD2301SAL	ALD2301PAL	ALD2301DA

* Contact factory for leaded (non-RoHS) or high temperature versions.

BLOCK DIAGRAM

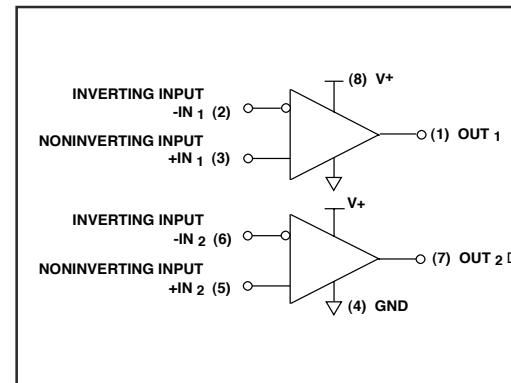

ABSOLUTE MAXIMUM RATINGS

Supply voltage, V₊ _____ 10.6V
 Differential input voltage range _____ -0.3V to V₊ +0.3V
 Power dissipation _____ 600 mW
 Operating temperature range SAL, PAL packages _____ 0°C to +70°C
 DA package _____ -55°C to +125°C
 Storage temperature range _____ -65°C to +150°C
 Lead temperature, 10 seconds _____ +260°C

OPERATING ELECTRICAL CHARACTERISTICS

T_A = 25°C V₊ = +5V unless otherwise specified

Parameter	Symbol	2301A			2301B			2301C			2301			Unit	Test Conditions
		Min	Typ	Max	Min	Typ	Max	Min	Typ	Max	Min	Typ	Max		
Supply Voltage	V _S V ₊	±1.5 3		±5 10	±1.5 3		±5 10	±1.5 3		±5 10	±1.5 3		±5 10	V V	Dual Supply Single Supply
Supply Current	I _S		110	180		110	180		110	180		110	180	µA	R _{LOAD} = ∞
Voltage Gain	A _{VD}	50	150		50	150		50	150		50	150		V/mV	R _{LOAD} ≥ 15KΩ
Input Offset Voltage	V _{OS}			2 2.5			5 5.8			20 20			10 11	mV mV	R _{LOAD} ≥ 1.5KΩ 0°C ≤ T _A ≤ +70°C
Input Offset Current ¹	I _{OS}		10	200		10	200		10	400		10	200	pA	
Input Bias Current ¹	I _B		10	200		10	200		10	400		10	200	pA	
Common Mode Input Voltage Range ²	V _{ICR}	-0.3		V ₊ -1.5	-0.3		V ₊ -1.5	-0.3		V ₊ -1.5	-0.3		V ₊ -1.5	V	
Low Level Output Voltage	V _{OL}		0.15	0.4		0.15	0.4		0.15	0.4		0.15	0.4	V	I _{SINK} = 12mA V _{INPUT} = 1V Differential
Low Level Output Current	I _{OL}	24	60		24	60		24	60		24	60		mA	V _{OL} = 1.0 V
High Level Leakage Current	I _{OH}		.01	20		.01	20		.01	20		.01	20	nA	V _{OH} = 5.0 V
Response Time ²	t _{RP}		650			650			650			650		ns	R _L = 5.1KΩ C _L = 15pF 100mV Input Step/5mV Overdrive
			300			300			300			300		ns	R _L = 5.1KΩ C _L = 15pF TTL - Level Input Step

Notes : ¹ Consists of junction leakage currents.
² Sample tested parameters.

TYPICAL PERFORMANCE CHARACTERISTICS

SATURATION VOLTAGE vs. TEMPERATURE

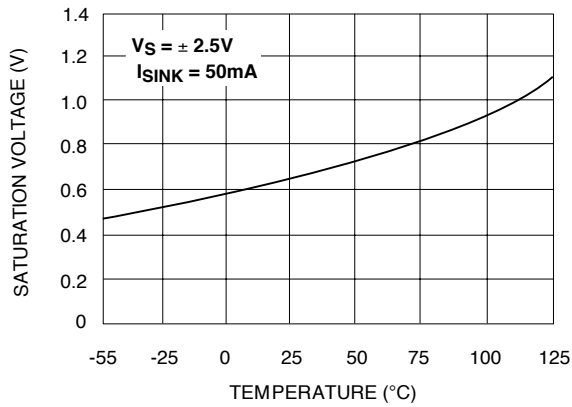

TRANSFER FUNCTION

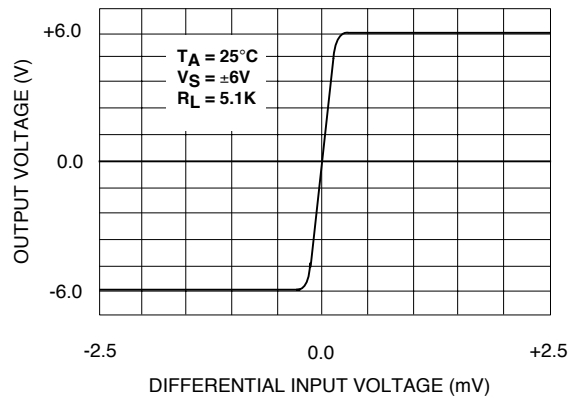

COMMON - MODE VOLTAGE REFERRED TO SUPPLY VOLTAGE

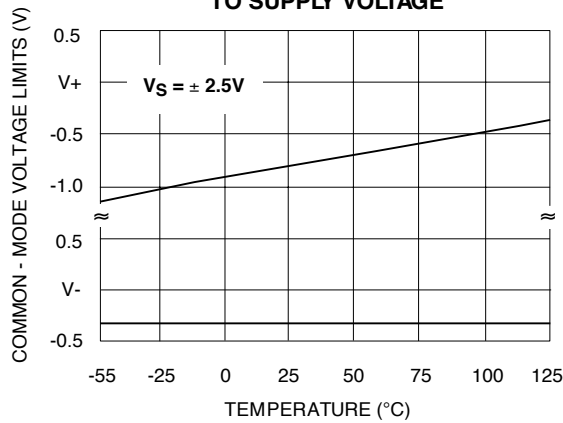

RESPONSE TIME FOR VARIOUS INPUT OVERDRIVES

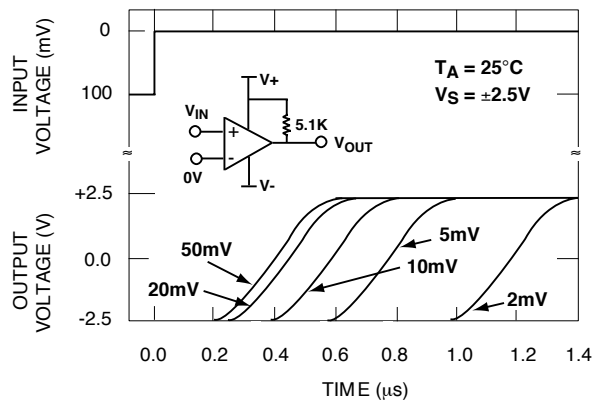

SATURATION VOLTAGE vs. SINK CURRENT

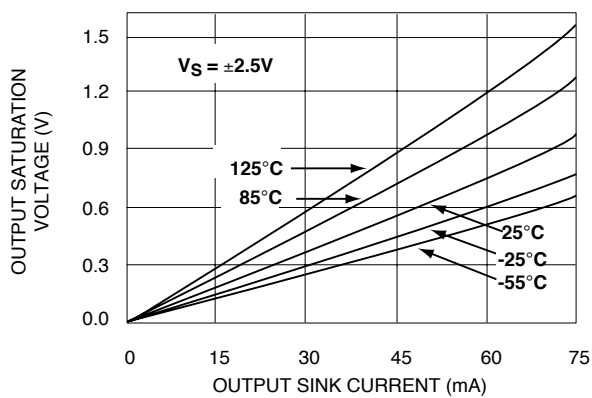

RESPONSE TIME FOR VARIOUS INPUT OVERDRIVES

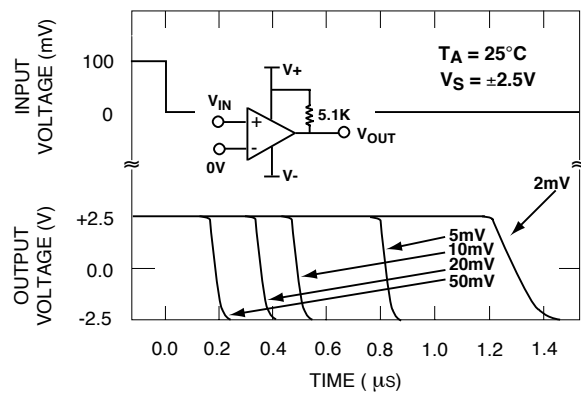

TYPICAL PERFORMANCE CHARACTERISTICS (cont'd)

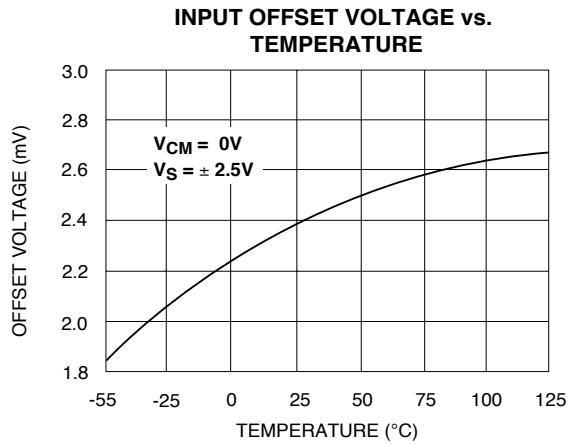
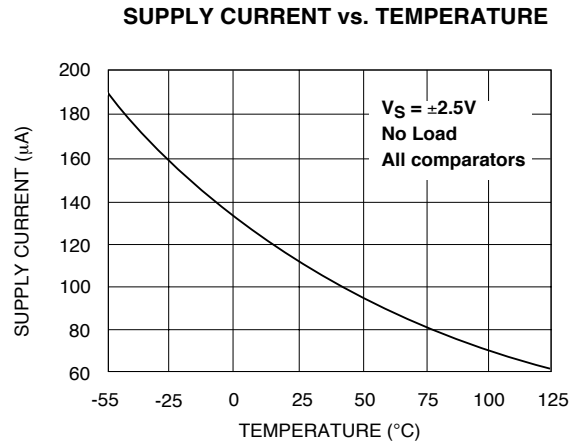
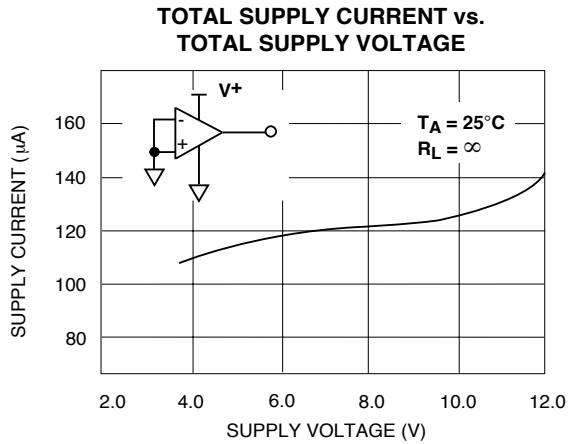

TYPICAL APPLICATIONS

DUAL LIMIT WINDOW COMPARATOR

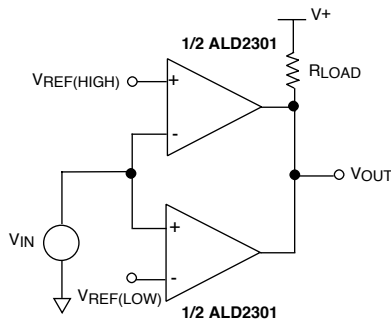

MINIMUM $R_{LOAD} = 1.5K\Omega$

OUTPUT HIGH FOR $V_{IN} < V_{REF(HIGH)}$

AND $V_{IN} > V_{REF(LOW)}$

DUAL LIMIT PHOTO-DETECTOR MONITOR

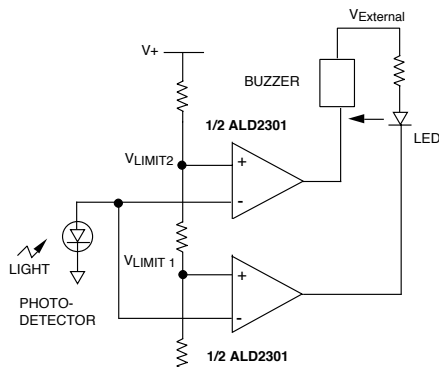

LED turns on as photo-detector voltage reaches V_{LIMIT1} . Both LED and horn turns on as photo-detector voltage reaches V_{LIMIT2} .
VEXTERNAL = +12V V+ = +5V.

VOLTAGE COMPARATOR WITH COMPLEMENTARY OUTPUTS

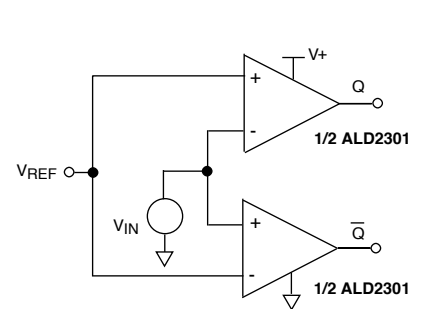

SOIC-8 PACKAGE DRAWING

8 Pin Plastic SOIC Package

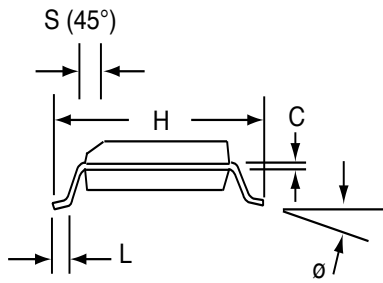
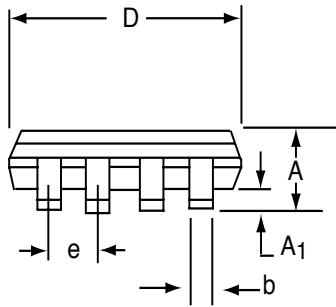
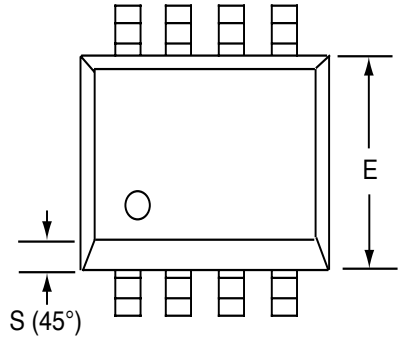

Dim	Millimeters		Inches	
	Min	Max	Min	Max
A	1.35	1.75	0.053	0.069
A ₁	0.10	0.25	0.004	0.010
b	0.35	0.45	0.014	0.018
C	0.18	0.25	0.007	0.010
D-8	4.69	5.00	0.185	0.196
E	3.50	4.05	0.140	0.160
e	1.27 BSC		0.050 BSC	
H	5.70	6.30	0.224	0.248
L	0.60	0.937	0.024	0.037
∅	0°	8°	0°	8°
S	0.25	0.50	0.010	0.020

□

PDIP-8 PACKAGE DRAWING

8 Pin Plastic DIP Package

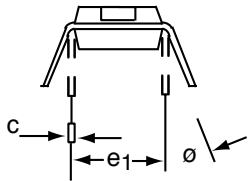
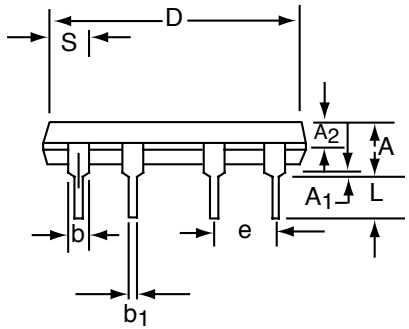
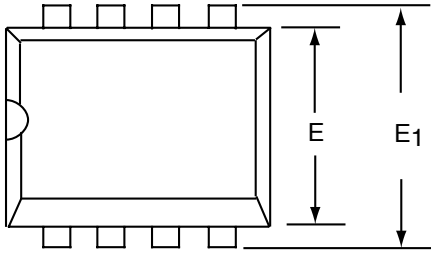

Dim	Millimeters		Inches	
	Min	Max	Min	Max
A	3.81	5.08	0.105	0.200
A₁	0.38	1.27	0.015	0.050
A₂	1.27	2.03	0.050	0.080
b	0.89	1.65	0.035	0.065
b₁	0.38	0.51	0.015	0.020
c	0.20	0.30	0.008	0.012
D-8	9.40	11.68	0.370	0.460
E	5.59	7.11	0.220	0.280
E₁	7.62	8.26	0.300	0.325
e	2.29	2.79	0.090	0.110
e₁	7.37	7.87	0.290	0.310
L	2.79	3.81	0.110	0.150
S-8	1.02	2.03	0.040	0.080
θ	0°	15°	0°	15°

CERDIP-8 PACKAGE DRAWING

8 Pin CERDIP Package

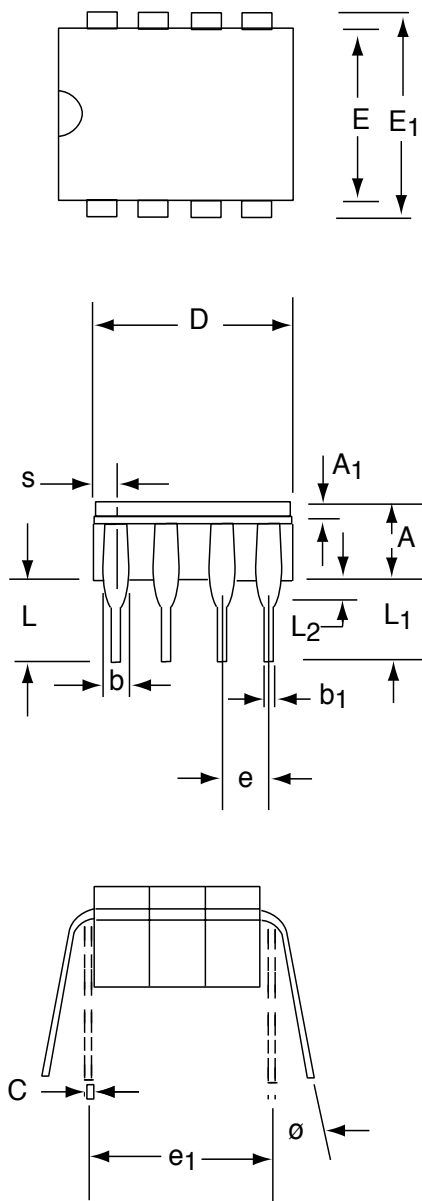

Dim	Millimeters		Inches	
	Min	Max	Min	Max
A	3.55	5.08	0.140	0.200
A ₁	1.27	2.16	0.050	0.085
b	0.97	1.65	0.038	0.065
b ₁	0.36	0.58	0.014	0.023
C	0.20	0.38	0.008	0.015
D-8	--	10.29	--	0.405
E	5.59	7.87	0.220	0.310
E ₁	7.73	8.26	0.290	0.325
e	□2.54 BSC		0.100 BSC	
e ₁	□7.62 BSC		0.300 BSC	
L	3.81	5.08	0.150	0.200
L ₁	3.18	--	0.125	--
L ₂	0.38	1.78	0.015	0.070
S	--	2.49	--	0.098
∅	0°	15°	0°	15°

Looking for pricing, stock, or lifecycle information?

Click below to explore more details on WIN SOURCE:

- ⊖ [View ALD2301ASAL on WIN SOURCE](#)
- ⊖ [Advanced Linear Devices Inc. Information](#)

Optimize Your Supply Chain with WIN SOURCE Solutions

- ✓ Global Sourcing Solution
- ✓ Obsolete Management
- ✓ Cost Control Management
- ✓ Shortage Management
- ✓ Alternative Solution
- ✓ Excess Inventory Management