



**THE DATASHEET OF
AFE4403YZPT**



AFE4403 Ultra-Small, Integrated Analog Front-End for Heart Rate Monitors and Low-Cost Pulse Oximeters

1 Features

- Fully-Integrated AFE for Pulse Oximeter and Heart Rate Monitoring Applications:
- Transmit:
 - Integrated Dual LED Driver (H-Bridge or Common Anode)
 - Option for a Third LED Support for Optimized SPO₂, HRM, or Multi-Wavelength HRM
 - Up to 110-dB Dynamic Range
 - LED Current:
 - Programmable to 100 mA with 8-Bit Current Resolution
 - 30 μ A + Average LED Current
 - Programmable LED On-Time
 - Independent LED2 and LED1 Current Reference
- Receive Channel with High Dynamic Range:
 - 22-Bit Output in Twos Complement Format
 - Up to 105-dB Dynamic Range
 - Low Power: < 650 μ A
 - Dynamic Power-Down Mode to Reduce Current to 300 μ A
 - Adaptable to a Very Wide Range of Signal Amplitudes:
 - Total Programmable Gain: 10 k Ω to 4 M Ω
 - Integrated Digital Ambient Estimation and Subtraction
- Flexible Clocking by External Clock or Crystal:
 - Pulse Frequency: 62.5 SPS to 2000 SPS
 - Flexible Pulse sequencing and Timing Control
 - Input Clock Range: 4 MHz (Min) to 60 MHz (Max)
- Integrated Fault Diagnostics:
 - Photodiode and LED Open and Short Detection
- Supplies:
 - Rx = 2.0 V to 3.6 V
 - Tx = 3.0 V to 5.25 V
- Package: Compact DSBGA-36 (3.07 mm \times 3.07 mm \times 0.5 mm)
- Specified Temperature Range: -20°C to 70°C

2 Applications

- Medical Pulse Oximeter Applications
- Optical HRM
- Industrial Photometry Applications

3 Description

The AFE4403 is a fully-integrated analog front-end (AFE) ideally suited for pulse oximeter applications. The device consists of a low-noise receiver channel with an integrated analog-to-digital converter (ADC), an LED transmit section, and diagnostics for sensor and LED fault detection. The device is a very configurable timing controller. This flexibility enables the user to have complete control of the device timing characteristics. To ease clocking requirements and provide a low-jitter clock to the AFE4403, an oscillator is also integrated that functions from an external crystal. The device communicates to an external microcontroller or host processor using an SPI™ interface.

The device is a complete AFE solution packaged in a single, compact DSBGA-36 (3.07 mm \times 3.07 mm \times 0.5 mm) and is specified over the operating temperature range of -20°C to 70°C .

Device Information⁽¹⁾

PART NUMBER	PACKAGE	BODY SIZE (NOM)
AFE4403	DSBGA (36)	3.07 mm \times 3.07 mm

(1) For all available packages, see the orderable addendum at the end of the datasheet.

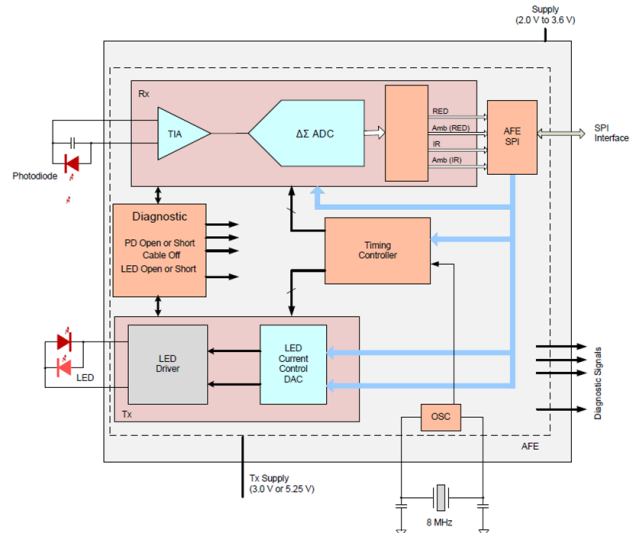

Table of Contents

1 Features	1	8.2 Functional Block Diagram	20
2 Applications	1	8.3 Feature Description	21
3 Description	1	8.4 Device Functional Modes	45
4 Revision History	2	8.5 Programming	53
5 Device Family Options	3	8.6 Register Maps	58
6 Pin Configuration and Functions	3	9 Application and Implementation	83
7 Specifications	5	9.1 Application Information	83
7.1 Absolute Maximum Ratings	5	9.2 Typical Application	83
7.2 Handling Ratings	5	10 Power Supply Recommendations	87
7.3 Recommended Operating Conditions	6	10.1 Power Consumption Considerations	88
7.4 Thermal Information	6	11 Layout	90
7.5 Electrical Characteristics	7	11.1 Layout Guidelines	90
7.6 Timing Requirements	11	11.2 Layout Example	90
7.7 Timing Requirements: Supply Ramp and Power-Down	12	12 Device and Documentation Support	91
7.8 Typical Characteristics	14	12.1 Trademarks	91
8 Detailed Description	20	12.2 Electrostatic Discharge Caution	91
8.1 Overview	20	12.3 Glossary	91
		13 Mechanical, Packaging, and Orderable Information	91

4 Revision History

Changes from Revision A (June 2014) to Revision B

Page

• Changed Pin Configuration diagram: changed <i>Top View</i> to <i>Bottom View</i>	3
• Added footnote to Figure 41	27

Changes from Original (May 2014) to Revision A

Page

• Changed document status to Production Data	1
• Changed first and third sub-bullets of <i>Flexible Clocking</i> Features bullet	1
• Changed MIN to NOM in Body Size column of Device Information table	1
• Added Device Family Options table and Pin Configuration and Functions section	3
• Added Specifications section	5
• Added <i>Detailed Description</i> section	20
• Added <i>Application and Implementation</i> section	83
• Added <i>Power Supply Recommendations</i> section	87
• Added <i>Layout</i> section	90

5 Device Family Options

PRODUCT	PACKAGE-LEAD	LED DRIVE CONFIGURATION	LED DRIVE CURRENT (mA, max)	Tx POWER SUPPLY (V)	OPERATING TEMPERATURE RANGE
AFE4400	VQFN-40	Bridge, push-pull	50	3 to 5.25	0°C to 70°C
AFE4490	VQFN-40	Bridge, push-pull	50, 75, 100, 150, and 200	3 to 5.25	-40°C to 85°C
AFE4403	DSBGA-36	Bridge, push-pull	25, 50, 75, and 100	3 to 5.25	-20°C to 70°C

6 Pin Configuration and Functions

YZP Package
DSBGA-36
(Bottom View)

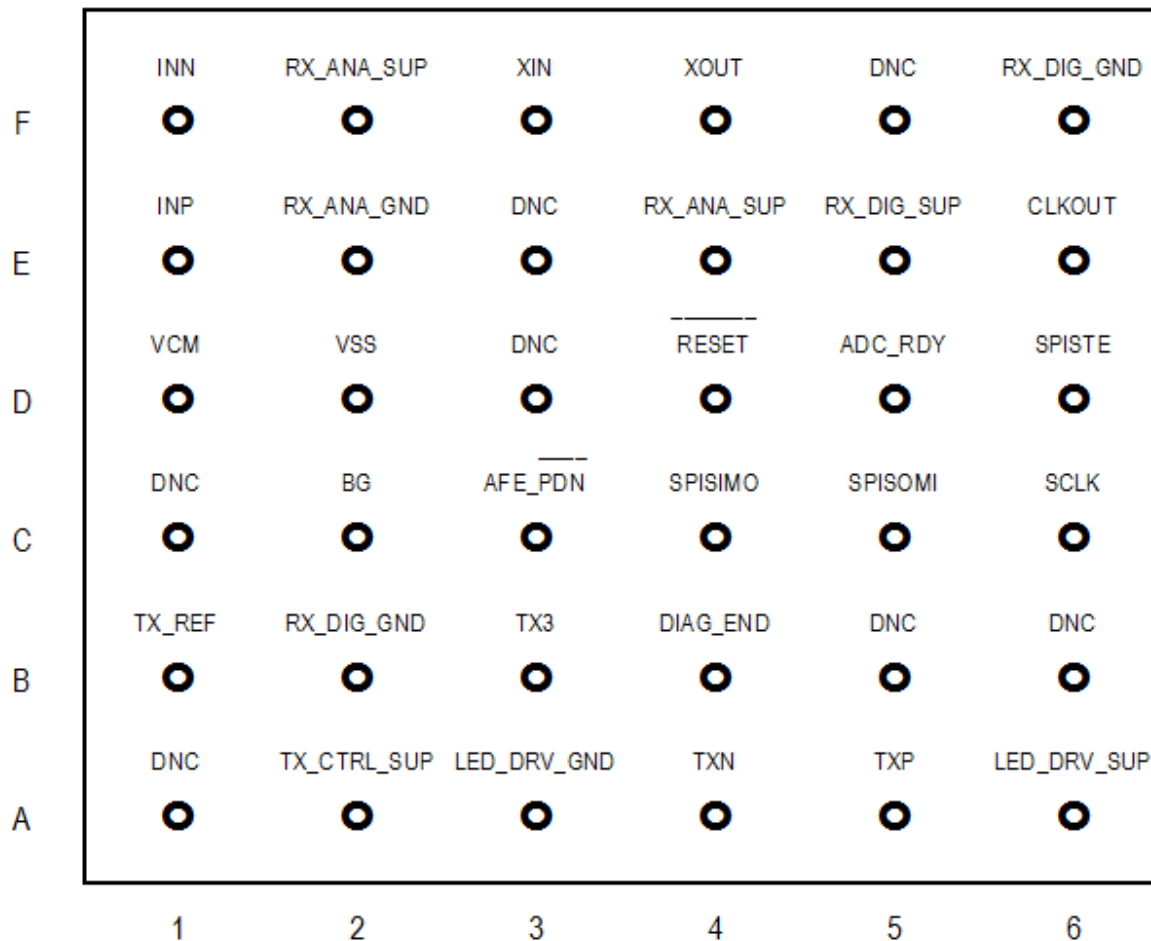

Pin Functions

PIN		FUNCTION	DESCRIPTION
NAME	NO.		
ADC_RDY	D5	Digital	Output signal that indicates ADC conversion completion. Can be connected to the interrupt input pin of an external microcontroller.
AFE_PDN	C3	Digital	AFE-only power-down input; active low. Can be connected to the port pin of an external microcontroller.
BG	C2	Reference	Decoupling capacitor for internal band-gap voltage to ground. Connect a decoupling capacitor to ground. To achieve the lowest transmitter noise, use a capacitor value of 2.2 μF . To reduce the recovery time from power-down (from 1 s to 0.1 s), use a capacitor value of 0.1 μF instead—but with slightly degraded transmitter noise.
CLKOUT	E6	Digital	Buffered 4-MHz output clock output. Can be connected to the clock input pin of an external microcontroller.
DIAG_END	B4	Digital	Output signal that indicates completion of diagnostics. Can be connected to the port pin of an external microcontroller.
DNC ⁽¹⁾	C1, A1, E3, D3, F5, B5, B6	—	Do not connect these pins. Leave as open circuit.
INN	F1	Analog	Receiver input pin. Connect to photodiode anode.
INP	E1	Analog	Receiver input pin. Connect to photodiode cathode.
LED_DRV_GND	A3	Supply	LED driver ground pin, H-bridge. Connect to common board ground.
LED_DRV_SUP	A6	Supply	LED driver supply pin, H-bridge. Connect to an external power supply capable of supplying the large LED current, which is drawn by this supply pin.
RESET	D4	Digital	AFE-only reset input, active low. Can be connected to the port pin of an external microcontroller.
RX_ANA_GND	E2	Supply	Rx analog ground pin. Connect to common board ground.
RX_ANA_SUP	F2, E4	Supply	Rx analog supply pin; 0.1- μF decoupling capacitor to ground
RX_DIG_GND	B2, F6	Supply	Rx digital ground pin. Connect to common board ground.
RX_DIG_SUP	E5	Supply	Rx digital supply pin; 0.1- μF decoupling capacitor to ground
SCLK	C6	SPI	SPI clock pin
SPISIMO	C4	SPI	SPI serial in master out
SPISOMI	C5	SPI	SPI serial out master in
SPISTE	D6	SPI	SPI serial interface enable
TX_CTRL_SUP	A2	Supply	Transmit control supply pin (0.1- μF decoupling capacitor to ground)
TX_REF	B1	Reference	Transmitter reference voltage, 0.25 V default after reset. Connect a decoupling capacitor to ground. To achieve the lowest transmitter noise, use a capacitor value of 2.2 μF . To reduce the recovery time from power-down (from 1 s to 0.1 s), use a capacitor value of 0.1 μF instead—but with slightly degraded transmitter noise.
TXN	A4	Analog	LED driver out. Connect to LED in common anode or H-bridge configuration.
TXP	A5	Analog	LED driver out. Connect to LED in common anode or H-bridge configuration.
TX3	B3	Analog	LED driver out for third LED. Connect to optional third LED supported in common anode configuration.
VCM	D1	Reference	Input common-mode voltage output. This signal can be used to shield (guard) the INP, INN traces. If used as a shield, then connect a series resistor (1 k Ω) and a decoupling capacitor (10 nF) to ground. If VCM is not used externally, then these external components are not required.
VSS	D2	Supply	Substrate ground. Connect to common board ground.
XOUT	F4	Digital	Crystal oscillator pins. Connect an external crystal between these pins with the correct load capacitor (as specified by vendor) to ground.
XIN	F3	Digital	Crystal oscillator pins. Connect an external crystal between these pins with the correct load capacitor (as specified by vendor) to ground.

(1) Leave pins as open circuit. Do not connect.

7 Specifications

7.1 Absolute Maximum Ratings

over operating free-air temperature range (unless otherwise noted)⁽¹⁾

		MIN	MAX	UNIT
RX_ANA_SUP, RX_DIG_SUP to RX_ANA_GND, RX_DIG_GND		-0.3	4	V
TX_CTRL_SUP, LED_DRV_SUP to LED_DRV_GND		-0.3	6	V
RX_ANA_GND, RX_DIG_GND to LED_DRV_GND		-0.3	0.3	V
Analog inputs		RX_ANA_GND – 0.3	RX_ANA_SUP + 0.3	V
Digital inputs		RX_DIG_GND – 0.3	RX_DIG_SUP + 0.3	V
Input current to any pin except supply pins ⁽²⁾			±7	mA
Input current	Momentary		±50	mA
	Continuous		±7	mA
Operating temperature range		0–20	70	°C
Maximum junction temperature, T _J			125	°C

(1) Stresses beyond those listed under *Absolute Maximum Ratings* may cause permanent damage to the device. These are stress ratings only, which do not imply functional operation of the device at these or any other conditions beyond those indicated under *Recommended Operating Conditions*. Exposure to absolute-maximum-rated conditions for extended periods may affect device reliability.

(2) Input terminals are diode-clamped to the power-supply rails. Input signals that can swing beyond the supply rails must be current-limited to 10 mA or less.

7.2 Handling Ratings

			MIN	MAX	UNIT
T _{stg}	Storage temperature range		-60	150	°C
V _(ESD)	Electrostatic discharge	Human body model (HBM), per ANSI/ESDA/JEDEC JS-001, all pins ⁽¹⁾	-1000	1000	V
		Charged device model (CDM), per JEDEC specification JESD22-C101, all pins ⁽²⁾	-250	250	

(1) JEDEC document JEP155 states that 500-V HBM allows safe manufacturing with a standard ESD control process.

(2) JEDEC document JEP157 states that 250-V CDM allows safe manufacturing with a standard ESD control process.

7.3 Recommended Operating Conditions

over operating free-air temperature range (unless otherwise noted)

PARAMETER		MIN	MAX	UNIT	
SUPPLIES					
RX_ANA_SUP	AFE analog supply	2.0	3.6	V	
RX_DIG_SUP	AFE digital supply	2.0	3.6	V	
TX_CTRL_SUP	Transmit controller supply	3.0	5.25	V	
LED_DRV_SUP	H-bridge	[3.0 or $(0.75 + V_{LED} + V_{CABLE})^{(1)(2)}$, whichever is greater]		5.25	V
	Common anode configuration	[3.0 or $(0.5 + V_{LED} + V_{CABLE})^{(1)(2)}$, whichever is greater]		5.25	V
Difference between LED_DRV_SUP and TX_CTRL_SUP		-0.3	0.3	V	
TEMPERATURE					
Specified temperature range		-20	70	°C	
Storage temperature range		-60	150	°C	

- (1) V_{LED} refers to the maximum voltage drop across the external LED (at maximum LED current) connected between the TXP and TXN pins (in H-bridge mode) and from the TXP and TXN pins to LED_DRV_SUP (in the common anode configuration).
- (2) V_{CABLE} refers to voltage drop across any cable, connector, or any other component in series with the LED.

7.4 Thermal Information

THERMAL METRIC ⁽¹⁾		AFE4403		UNIT
		YZP (WCSP)		
		36 BALLS		
$R_{\theta JA}$	Junction-to-ambient thermal resistance	49.8		°C/W
$R_{\theta JC(top)}$	Junction-to-case (top) thermal resistance	0.2		
$R_{\theta JB}$	Junction-to-board thermal resistance	8.5		
Ψ_{JT}	Junction-to-top characterization parameter	0.8		
Ψ_{JB}	Junction-to-board characterization parameter	8.5		
$R_{\theta JC(bot)}$	Junction-to-case (bottom) thermal resistance	n/a		

- (1) For more information about traditional and new thermal metrics, see the *IC Package Thermal Metrics* application report, [SPRA953](http://www.ti.com/lit/zip/Spra953).

7.5 Electrical Characteristics

Minimum and maximum specifications are at $T_A = -20^{\circ}\text{C}$ to 70°C , typical specifications are at 25°C . Crystal mode enabled, detector capacitor = 50 pF differential, ADC averaging set to maximum allowed for each PRF, TX_REF voltage set to 0.5 V, and CLKOUT tri-stated, at RX_ANA_SUP = RX_DIG_SUP = 3 V, TX_CTRL_SUP = LED_DRV_SUP = 3.3 V, stage 2 amplifier disabled, and $f_{\text{CLK}} = 8$ MHz, unless otherwise noted.

PARAMETER		TEST CONDITIONS	MIN	TYP	MAX	UNIT
PERFORMANCE (Full-Signal Chain)						
$I_{\text{IN_FS}}$	Full-scale input current	$R_F = 10$ k Ω		50		μA
		$R_F = 25$ k Ω		20		μA
		$R_F = 50$ k Ω		10		μA
		$R_F = 100$ k Ω		5		μA
		$R_F = 250$ k Ω		2		μA
		$R_F = 500$ k Ω		1		μA
		$R_F = 1$ M Ω		0.5		μA
PRF	Pulse repetition frequency		62.5		2000	SPS
DC _{PRF}	PRF duty cycle				25%	
CMRR	Common-mode rejection ratio	$f_{\text{CM}} = 50$ Hz and 60 Hz, LED1 and LED2 with $R_{\text{SERIES}} = 500$ k Ω , $R_F = 500$ k Ω		75		dB
		$f_{\text{CM}} = 50$ Hz and 60 Hz, LED1-AMB and LED2-AMB with $R_{\text{SERIES}} = 500$ k Ω , $R_F = 500$ k Ω		95		dB
PSRR _{LED}	PSRR, transmit LED driver	With respect to ripple on LED_DRV_SUP		75		dB
PSRR _{TX}	PSRR, transmit control	With respect to ripple on TX_CTRL_SUP		60		dB
PSRR _{RX}	PSRR, receiver	With respect to ripple on RX_ANA_SUP and RX_DIG_SUP		60		dB
	Total integrated noise current, input-referred (receiver with transmitter loop back, 0.1-Hz to 20-Hz bandwidth)	$R_F = 100$ k Ω , PRF = 600 Hz, duty cycle = 5%		25		pA _{RMS}
		$R_F = 500$ k Ω , PRF = 600 Hz, duty cycle = 5%		6		pA _{RMS}
RECEIVER FUNCTIONAL BLOCK LEVEL SPECIFICATION						
	Total integrated noise current, input referred (receiver alone) over 0.1-Hz to 20-Hz bandwidth	$R_F = 500$ k Ω , ambient cancellation enabled, stage 2 gain = 4, PRF = 1200 Hz, LED duty cycle = 25%		3.2		pA _{RMS}
		$R_F = 500$ k Ω , ambient cancellation enabled, stage 2 gain = 4, PRF = 1200 Hz, LED duty cycle = 5%		5.3		pA _{RMS}
I-V TRANSIMPEDANCE AMPLIFIER						
G	Gain	$R_F = 10$ k Ω to 1 M Ω	See the Receiver Channel section for details			V/ μA
	Gain accuracy		±7%			
	Feedback resistance	R_F	10k, 25k, 50k, 100k, 250k, 500k, and 1M			Ω
	Feedback resistor tolerance	R_F	±20%			
	Feedback capacitance	C_F	5, 10, 25, 50, 100, and 250			pF
	Feedback capacitor tolerance	C_F	±20%			
	Full-scale differential output voltage		1			V
	Common-mode voltage on input pins	Set internally	0.9			V
	External differential input capacitance	Includes equivalent capacitance of photodiode, cables, EMI filter, and so forth	10		1000	pF
	Shield output voltage, V_{CM}	With a 1-k Ω series resistor and a 10-nF decoupling capacitor to ground	0.8	0.9	1	V

Electrical Characteristics (continued)

Minimum and maximum specifications are at $T_A = -20^{\circ}\text{C}$ to 70°C , typical specifications are at 25°C . Crystal mode enabled, detector capacitor = 50 pF differential, ADC averaging set to maximum allowed for each PRF, TX_REF voltage set to 0.5 V, and CLKOUT tri-stated, at RX_ANA_SUP = RX_DIG_SUP = 3 V, TX_CTRL_SUP = LED_DRV_SUP = 3.3 V, stage 2 amplifier disabled, and $f_{\text{CLK}} = 8$ MHz, unless otherwise noted.

PARAMETER	TEST CONDITIONS	MIN	TYP	MAX	UNIT	
AMBIENT CANCELLATION STAGE						
Gain		0, 3.5, 6, 9.5, and 12			dB	
Current DAC range		0			10	μA
Current DAC step size		1				μA
LOW-PASS FILTER						
Low-pass corner frequency	3-dB attenuation	500				Hz
Pass-band attenuation, 2 Hz to 10 Hz	Duty cycle = 25%	0.004				dB
	Duty cycle = 10%	0.041				dB
Filter settling time	After diagnostics mode	28				ms
ANALOG-TO-DIGITAL CONVERTER						
Resolution		22				Bits
Sample rate	See the ADC Operation and Averaging Module section	4 x PRF				SPS
ADC full-scale voltage		± 1.2				V
ADC conversion time	See the ADC Operation and Averaging Module section	PRF / 4				μs
ADC reset time ⁽¹⁾		2				t_{CLK}
TRANSMITTER						
Output current range		Selectable, 0 to 100 (see the LEDCNTRL: LED Control Register for details)				mA
LED current DAC error		$\pm 10\%$				
Output current resolution		8				Bits
Transmitter noise dynamic range, over 0.1-Hz to 20-Hz bandwidth, TX_REF set to 0.5 V	At 25-mA output current	110				dB
	At 50-mA output current	110				dB
Minimum sample time of LED1 and LED2 pulses		50				μs
LED current DAC leakage current	LED_ON = 0	1				μA
	LED_ON = 1	50				μA
LED current DAC linearity	Percent of full-scale current	0.50				%
Output current settling time (with resistive load)	From zero current to 50 mA	7				μs
	From 50 mA to zero current	7				μs
DIAGNOSTICS						
Duration of diagnostics state machine	Start of diagnostics after the DIAG_EN register bit is set. End of diagnostic is indicated by DIAG_END going high.	16				ms
Open fault resistance		> 100				k Ω
Short fault resistance		< 10				k Ω
INTERNAL OSCILLATOR						
f_{CLKOUT} CLKOUT frequency	With an 8-MHz crystal connected to the XIN, XOUT pins	4				MHz
CLKOUT duty cycle		50%				
Crystal oscillator start-up time	With an 8-MHz crystal connected to the XIN, XOUT pins	200				μs

- (1) A low ADC reset time can result in a small component of the LED signal leaking into the ambient phase. With an ADC reset of two clock cycles, a -60 -dB leakage is expected. In many cases, this leakage does not affect system performance. However, if this crosstalk must be completely eliminated, a longer ADC reset time of approximately six clock cycles is recommended for t_{22} , t_{24} , t_{26} , and t_{28} in [Figure 48](#).

Electrical Characteristics (continued)

Minimum and maximum specifications are at $T_A = -20^{\circ}\text{C}$ to 70°C , typical specifications are at 25°C . Crystal mode enabled, detector capacitor = 50 pF differential, ADC averaging set to maximum allowed for each PRF, TX_REF voltage set to 0.5 V, and CLKOUT tri-stated, at RX_ANA_SUP = RX_DIG_SUP = 3 V, TX_CTRL_SUP = LED_DRV_SUP = 3.3 V, stage 2 amplifier disabled, and $f_{\text{CLK}} = 8$ MHz, unless otherwise noted.

PARAMETER	TEST CONDITIONS	MIN	TYP	MAX	UNIT
EXTERNAL CLOCK					
Maximum allowable external clock jitter	For SPO2 applications		50		ps
	For optical heart rate only			1000	ps
External clock input frequency ⁽²⁾	$\pm 2\%$	4	8	60	MHz
External clock input voltage	Voltage input high (V_{IH})		$0.75 \times$ RX_DIG_SUP		V
	Voltage input low (V_{IL})		$0.25 \times$ RX_DIG_SUP		V
TIMING					
Wake-up time from complete power-down			1000		ms
Wake-up time from Rx power-down			100		μs
Wake-up time from Tx power-down			1000		ms
t_{RESET}	Active low RESET pulse duration		1		ms
t_{DIAGEND}	DIAG_END pulse duration at the completion of diagnostics		4		CLKOUT cycles
t_{ADCRDY}	ADC_RDY pulse duration		1		CLKOUT cycle
DIGITAL SIGNAL CHARACTERISTICS					
V_{IH}	Logic high input voltage	AFE_PDN, SCLK, SPISIMO, SPISTE, RESET	0.8 DVDD	> 1.3 DVDD + 0.1	V
V_{IL}	Logic low input voltage	AFE_PDN, SCLK, SPISIMO, SPISTE, RESET	-0.1	< 0.4 0.2 DVDD	V
I_{IN}	Logic input current	$0\text{ V} < V_{\text{DigitalInput}} < \text{DVDD}$	-10	10	μA
V_{OH}	Logic high output voltage	DIAG_END, SPISOMI, ADC_RDY, CLKOUT	0.9 DVDD	$> (\text{RX_DIG_SUP} - 0.2\text{ V})$	V
V_{OL}	Logic low output voltage	DIAG_END, SPISOMI, ADC_RDY, CLKOUT		< 0.4 0.1 DVDD	V
SUPPLY CURRENT					
Receiver analog supply current	RX_ANA_SUP = 3.0 V, with 8-MHz clock running, Rx stage 2 disabled		0.6		mA
	RX_ANA_SUP = 3.0 V, with 8-MHz clock running, Rx stage 2 enabled		0.7		mA
	RX_ANA_SUP = 3.0 V, with 8-MHz clock running, Rx stage 2 disabled, external clock mode		0.49		mA
Receiver digital supply current	RX_DIG_SUP = 3.0 V		0.15		mA
LED driver supply current	With zero LED current setting		30		μA
Transmitter control supply current			15		μA
Complete power-down (using the AFE_PDN pin)	Receiver current only (RX_ANA_SUP)		3		μA
	Receiver current only (RX_DIG_SUP)		3		μA
	Transmitter current only (LED_DRV_SUP)		1		μA
	Transmitter current only (TX_CTRL_SUP)		1		μA
Power-down Rx alone	Receiver current only (RX_ANA_SUP)		200		μA
	Receiver current only (RX_DIG_SUP)		150		μA
Power-down Tx alone	Transmitter current only (LED_DRV_SUP)		2		μA
	Transmitter current only (TX_CTRL_SUP)		2		μA

(2) Refer to the CLKDIV[2:0] register bits for a detailed list of input clock frequencies that are supported.

Electrical Characteristics (continued)

Minimum and maximum specifications are at $T_A = -20^{\circ}\text{C}$ to 70°C , typical specifications are at 25°C . Crystal mode enabled, detector capacitor = 50 pF differential, ADC averaging set to maximum allowed for each PRF, TX_REF voltage set to 0.5 V, and CLKOUT tri-stated, at RX_ANA_SUP = RX_DIG_SUP = 3 V, TX_CTRL_SUP = LED_DRV_SUP = 3.3 V, stage 2 amplifier disabled, and $f_{\text{CLK}} = 8$ MHz, unless otherwise noted.

PARAMETER		TEST CONDITIONS		MIN	TYP	MAX	UNIT
POWER DISSIPATION							
Power-down with the AFE_PDN pin	LED_DRV_SUP	Does not include LED current.			1		μA
	TX_CTRL_SUP				1		μA
	RX_ANA_SUP				5		μA
	RX_DIG_SUP				0.1		μA
Power-down with the PDNAFE register bit	LED_DRV_SUP	Does not include LED current.			1		μA
	TX_CTRL_SUP				1		μA
	RX_ANA_SUP				15		μA
	RX_DIG_SUP				20		μA
Power-down Rx	LED_DRV_SUP	Does not include LED current.			30		μA
	TX_CTRL_SUP				15		μA
	RX_ANA_SUP				200		μA
	RX_DIG_SUP				150		μA
Power-down Tx	LED_DRV_SUP	Does not include LED current.			2		μA
	TX_CTRL_SUP				2		μA
	RX_ANA_SUP				600		μA
	RX_DIG_SUP				150		μA
After reset, with 8-MHz clock running	LED_DRV_SUP	Does not include LED current.			30		μA
	TX_CTRL_SUP				15		μA
	RX_ANA_SUP				600		μA
	RX_DIG_SUP				150		μA
With stage 2 mode enabled and 8-MHz clock running	LED_DRV_SUP	Does not include LED current.			30		μA
	TX_CTRL_SUP				15		μA
	RX_ANA_SUP				700		μA
	RX_DIG_SUP				150		μA
Dynamic power-down mode enabled	LED_DRV_SUP	Does not include LED current.	PRF = 100 Hz, PDN_CYCLE duration = 8 ms		7		μA
	TX_CTRL_SUP				5		μA
	RX_ANA_SUP				205		μA
	RX_DIG_SUP				150		μA

7.6 Timing Requirements

PARAMETER		MIN	TYP	MAX	UNIT
t_{CLK}	Clock frequency on the XIN pin		8		MHz
t_{SCLK}	Serial shift clock period	62.5			ns
t_{STECLK}	STE low to SCLK rising edge, setup time	10			ns
$t_{CLKSTEH,L}$	SCLK transition to SPI STE high or low	10			ns
t_{SIMOSU}	SIMO data to SCLK rising edge, setup time	10			ns
t_{SIMOHD}	Valid SIMO data after SCLK rising edge, hold time	10			ns
t_{SOMIPD}	SCLK falling edge to valid SOMI, setup time	17			ns
t_{SOMIHD}	SCLK rising edge to invalid data, hold time	0.5			t_{SCLK}

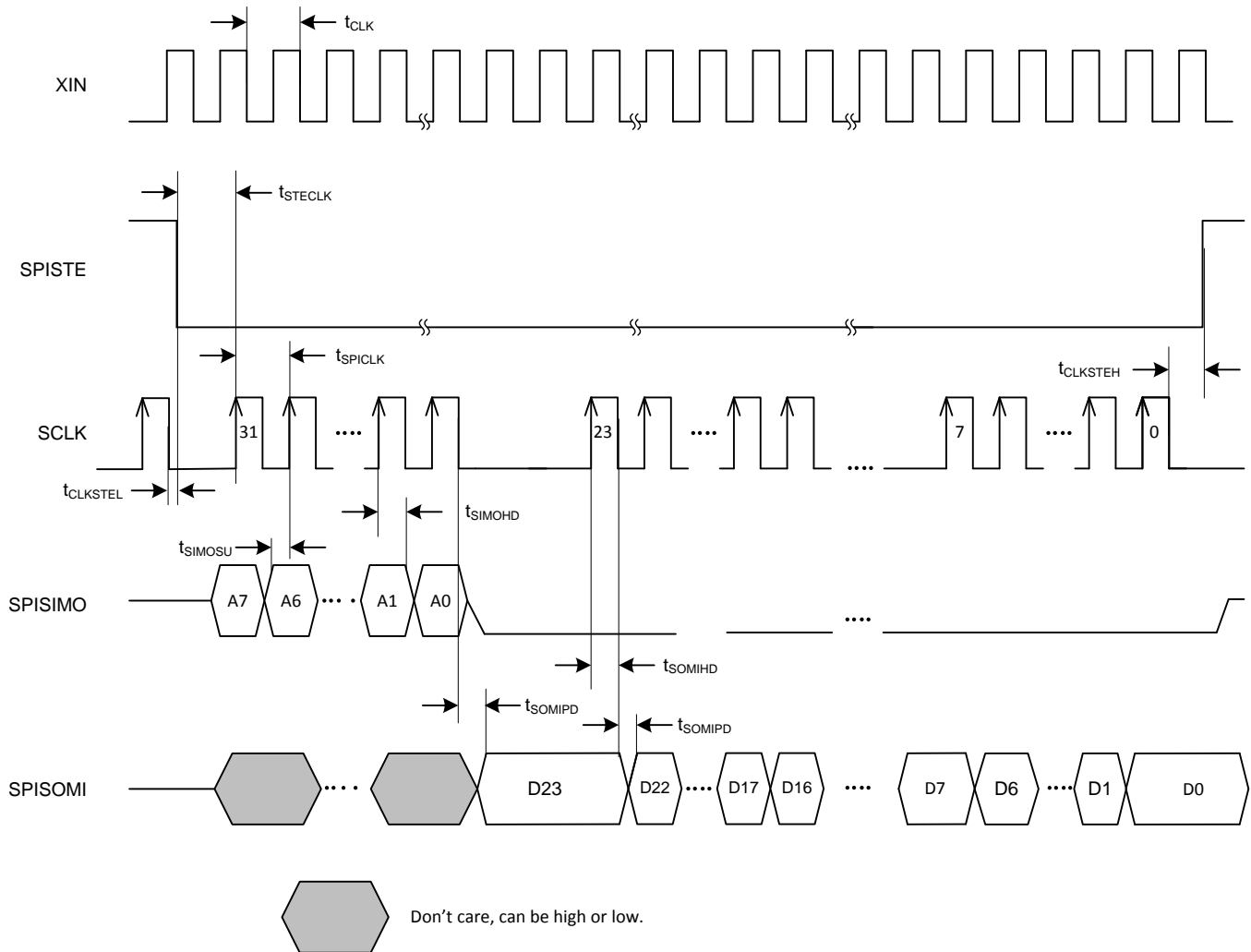

- (1) The SPI_READ register bit must be enabled before attempting a register read.
- (2) Specify the register address whose contents must be read back on A[7:0].
- (3) The AFE outputs the contents of the specified register on the SPISOMI pin.

Figure 1. Serial Interface Timing Diagram, Read Operation⁽¹⁾⁽²⁾⁽³⁾

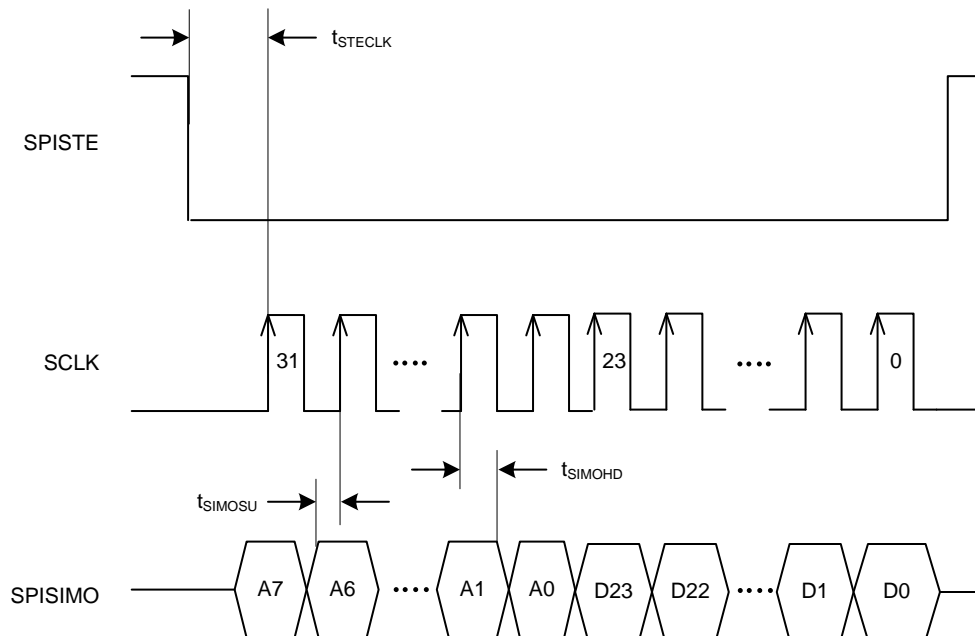
Figure 2. Serial Interface Timing Diagram, Write Operation

7.7 Timing Requirements: Supply Ramp and Power-Down

PARAMETER	VALUE
t_1 Time between Rx and Tx supplies ramping up	Keep as small as possible (for example, ± 10 ms)
t_2 Time between both supplies stabilizing and high-going $\overline{\text{RESET}}$ edge	> 100 ms
t_3 $\overline{\text{RESET}}$ pulse duration	> 0.5 ms
t_4 Time between $\overline{\text{RESET}}$ and SPI commands	> 1 μ s
t_5 Time between SPI commands and the $\overline{\text{ADC_RESET}}$ which corresponds to valid data	> 3 ms of cumulative sampling time in each phase ⁽¹⁾⁽²⁾⁽³⁾
t_6 Time between $\overline{\text{RESET}}$ pulse and high-accuracy data coming out of the signal chain	> 1 s ⁽³⁾
t_7 Time from $\overline{\text{AFE_PDN}}$ high-going edge and $\overline{\text{RESET}}$ pulse ⁽⁴⁾	> 100 ms
t_8 Time from $\overline{\text{AFE_PDN}}$ high-going edge (or $\overline{\text{PDN_AFE}}$ bit reset) to high-accuracy data coming out of the signal chain	> 1 s ⁽³⁾

- (1) This time is required for each of the four switched RC filters to fully settle to the new settings. The same time is applicable whenever there is a change to any of the signal chain controls (for example, LED current setting, TIA gain, and so forth).
- (2) If the SPI commands involve a change in the TX_REF value from its default, then there is additional wait time of approximately 1 s (for a 2.2- μ F decoupling capacitor on the TX_REF pin).
- (3) Dependent on the value of the capacitors on the BG and TX_REF pins. The 1-s wait time is necessary when the capacitors are 2.2 μ F and scale down proportionate to the capacitor value. A very low capacitor (for example, 0.1 μ F) on these pins causes the transmitter dynamic range to reduce to approximately 100 dB.
- (4) After an active power-down from $\overline{\text{AFE_PDN}}$, the device should be reset using a low-going $\overline{\text{RESET}}$ pulse.

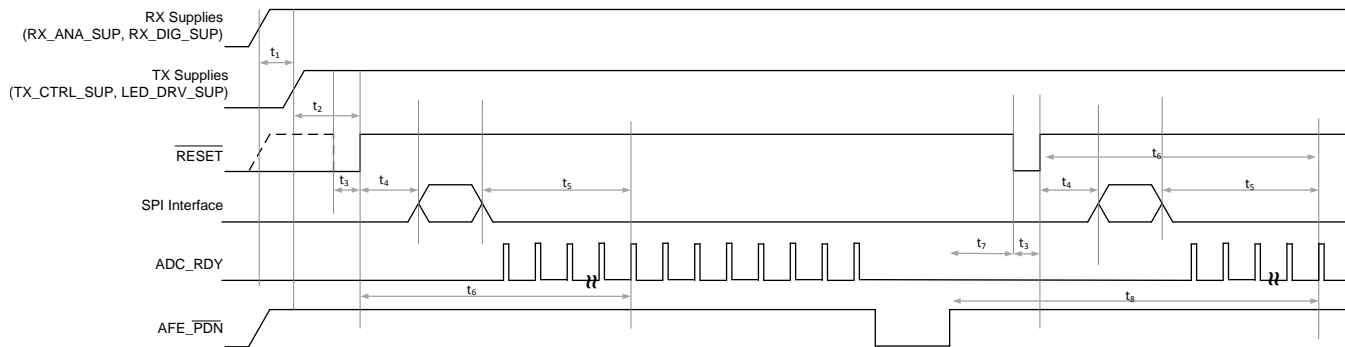

Figure 3. Supply Ramp and Hardware Power-Down Timing

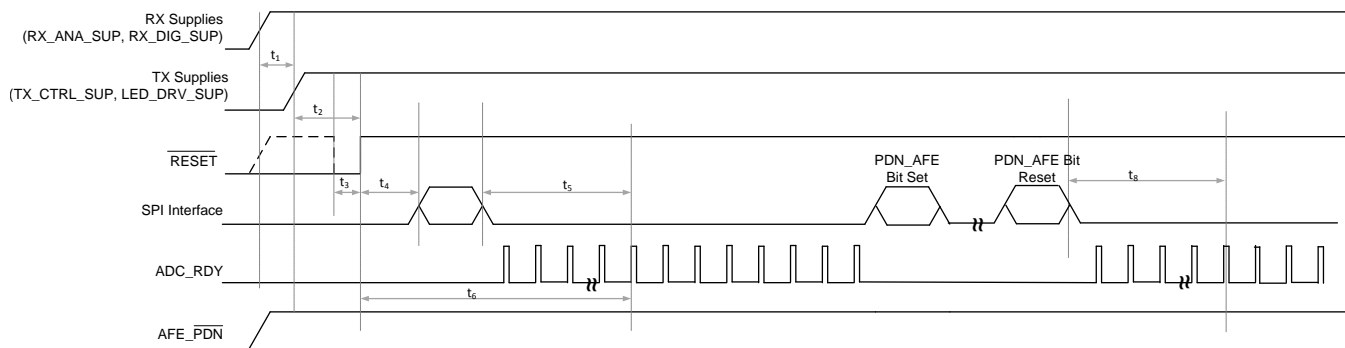

Figure 4. Supply Ramp and Software Power-Down Timing

7.8 Typical Characteristics

At PRF = 100 Hz, 25% duty cycle, $R_F = 500\text{ k}\Omega$, C_F is adjusted to keep TIA time constant at 1/10th of sampling duration, All supplies at 3.3 V, 8-MHz external clock, CLKOUT tri-state, 1- μF capacitor on TX_REF and BG pins, detector $C_{IN} = 50\text{ pF}$, TX_REF = 0.5 V, ADC averaging = max allowed, and SNR in dBFS is noise referred to full-scale range of 2 V, unless otherwise noted.

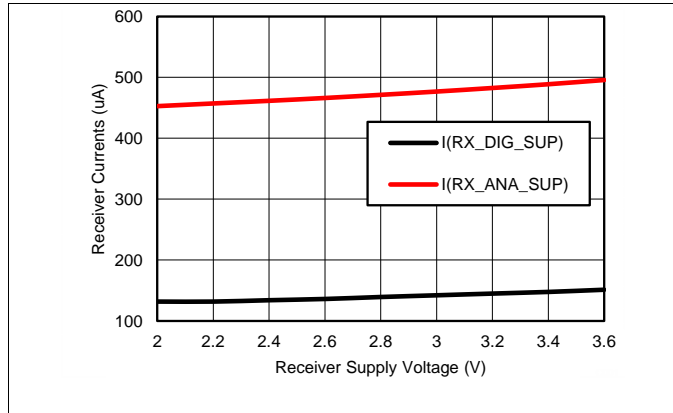
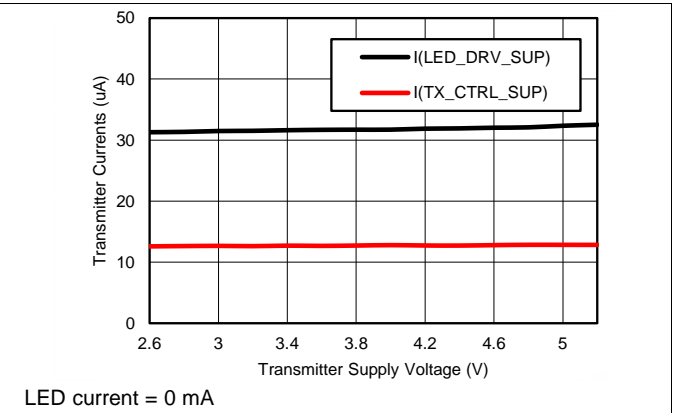
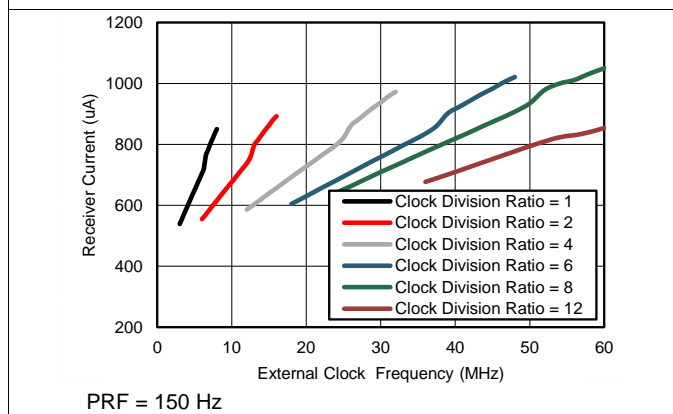

Figure 5. Receiver Currents vs Receiver Supply Voltage



LED current = 0 mA

Figure 6. Transmitter Currents vs Transmitter Supply Voltage



PRF = 150 Hz

Figure 7. Receiver Currents (Analog and Digital) vs Clock Divider Ratio

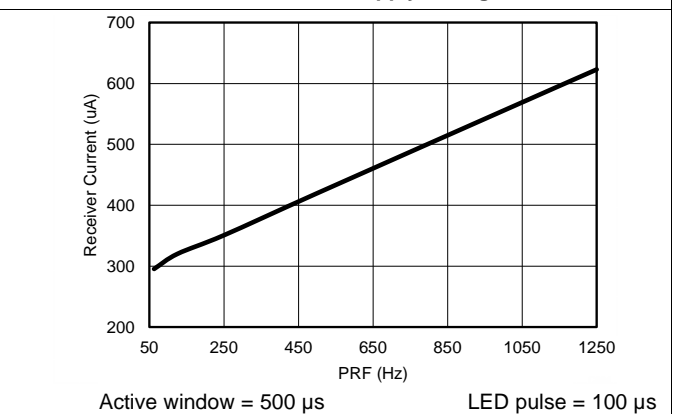

Active window = 500 μs

LED pulse = 100 μs

All four DYNAMIC bits set to 1

Figure 8. Receiver Current vs PRF in Dynamic Power-Down Mode

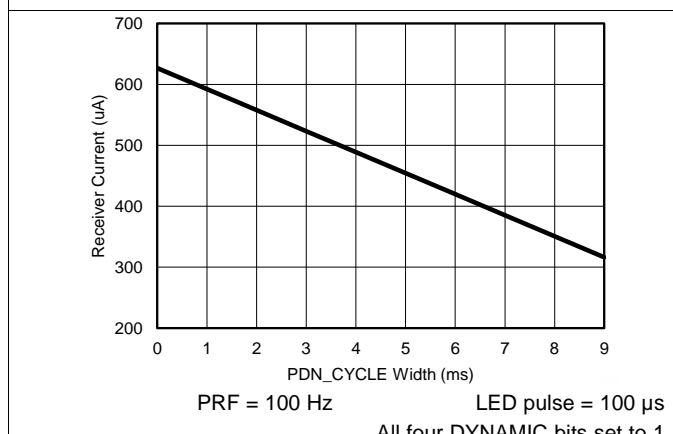

PRF = 100 Hz

LED pulse = 100 μs

All four DYNAMIC bits set to 1

Figure 9. Receiver Current (Analog and Digital) vs Dynamic Power-Down Duty Cycle

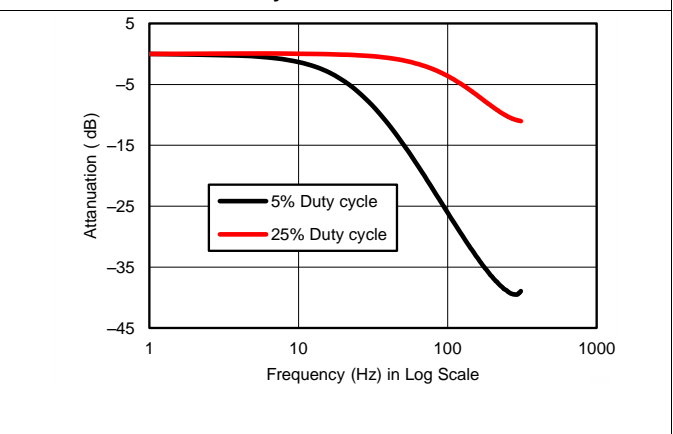
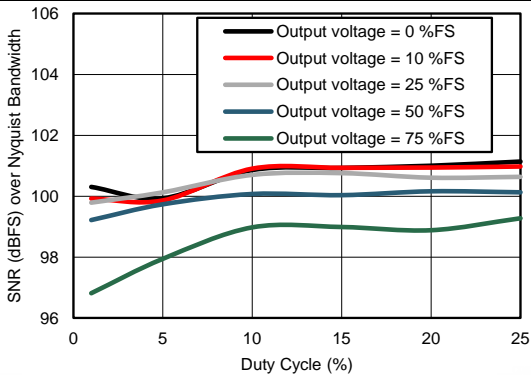

Figure 10. Filter Response vs Duty cycle

Typical Characteristics (continued)

At PRF = 100 Hz, 25% duty cycle, $R_F = 500\text{ k}\Omega$, C_F is adjusted to keep TIA time constant at 1/10th of sampling duration, All supplies at 3.3 V, 8-MHz external clock, CLKOUT tri-state, 1- μF capacitor on TX_REF and BG pins, detector $C_{IN} = 50\text{ pF}$, TX_REF = 0.5 V, ADC averaging = max allowed, and SNR in dBFS is noise referred to full-scale range of 2 V, unless otherwise noted.



500-Hz PRF

Figure 11. SNR over Nyquist Bandwidth vs Duty Cycle (Input Current with Tx-Rx Loopback)

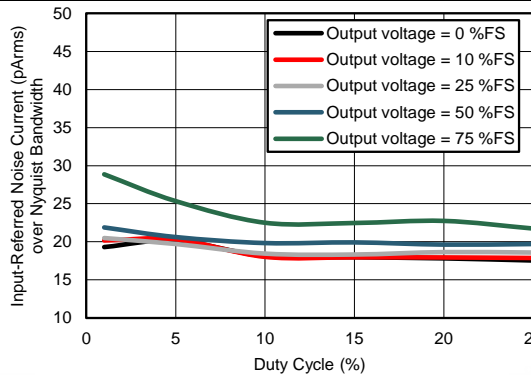

500-Hz PRF

Figure 12. Input-Referred Noise Current over Nyquist Bandwidth vs Duty Cycle (Input Current with Tx-Rx Loopback)

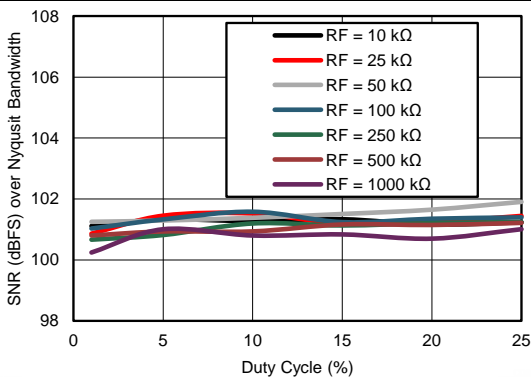

Figure 13. Receiver SNR over Nyquist Bandwidth vs Duty Cycle (Different Gain Settings)

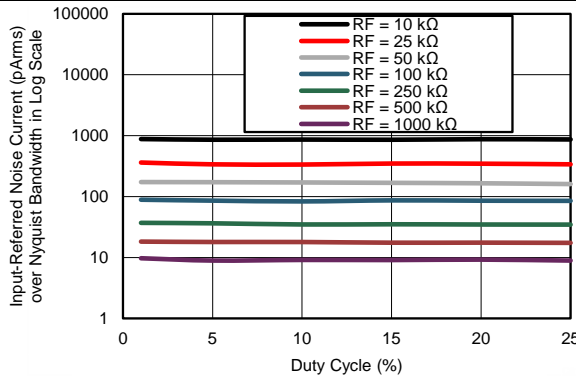

Figure 14. Receiver Input-Referred Noise Current over Nyquist Bandwidth vs Duty Cycle (Different Gain Settings)

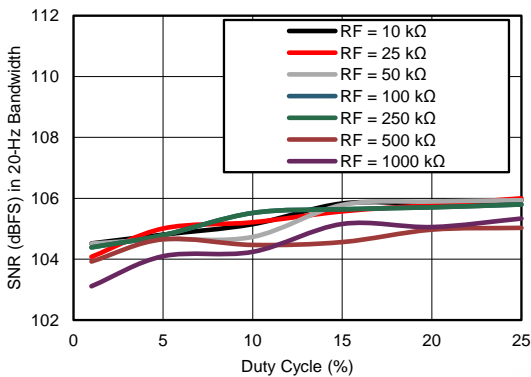

Figure 15. Receiver SNR in 20-Hz BW vs Duty Cycle (Different Gain Settings)

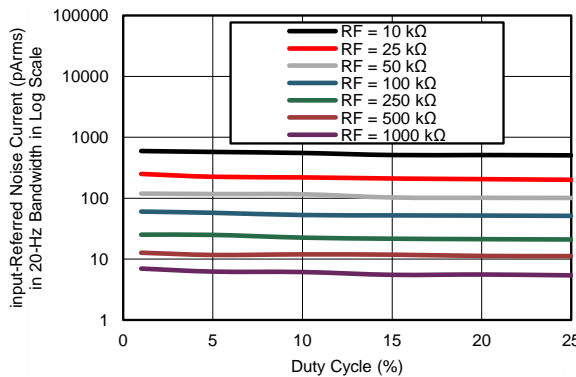

Figure 16. Receiver Input-Referred Noise Current in 20-Hz BW vs Duty Cycle (Different Gain Settings)

Typical Characteristics (continued)

At PRF = 100 Hz, 25% duty cycle, $R_F = 500\text{ k}\Omega$, C_F is adjusted to keep TIA time constant at 1/10th of sampling duration, All supplies at 3.3 V, 8-MHz external clock, CLKOUT tri-state, 1- μF capacitor on TX_REF and BG pins, detector $C_{IN} = 50\text{ pF}$, TX_REF = 0.5 V, ADC averaging = max allowed, and SNR in dBFS is noise referred to full-scale range of 2 V, unless otherwise noted.

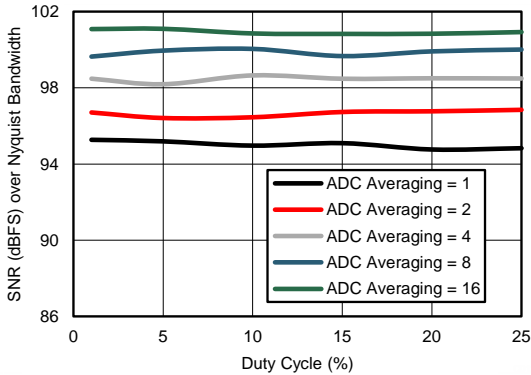

Figure 17. Receiver SNR over Nyquist Bandwidth vs Duty Cycle (Different ADC Averaging)

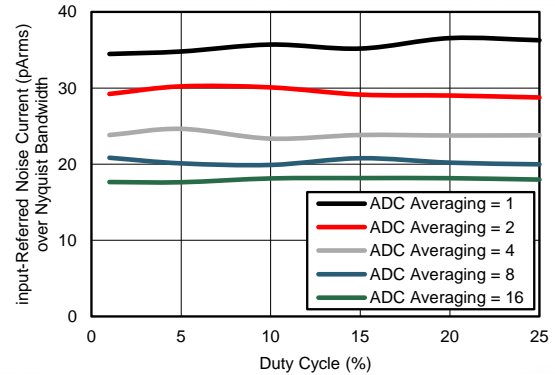

Figure 18. Receiver Input-Referred Noise Current over Nyquist Bandwidth vs Duty Cycle (Different ADC Averaging)

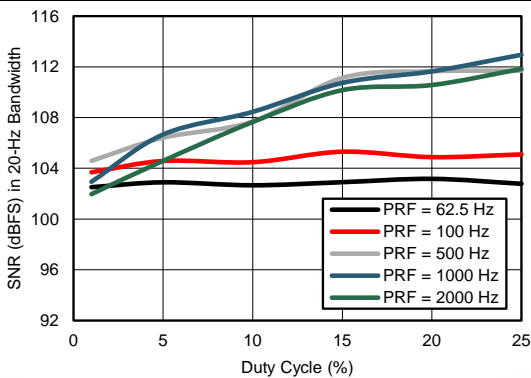

Figure 19. Receiver SNR in 20-Hz BW vs Duty Cycle (Different PRFs)

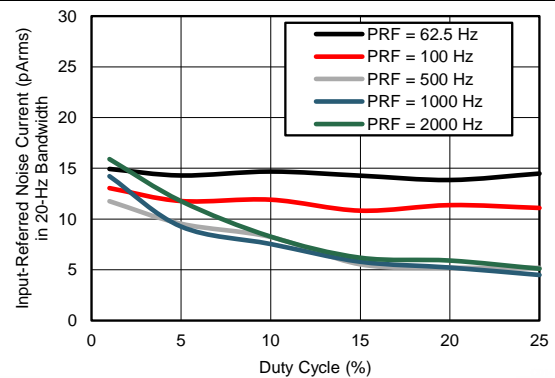

Figure 20. Receiver Input Referred Noise in 20-Hz BW vs Duty Cycle (Different PRFs)

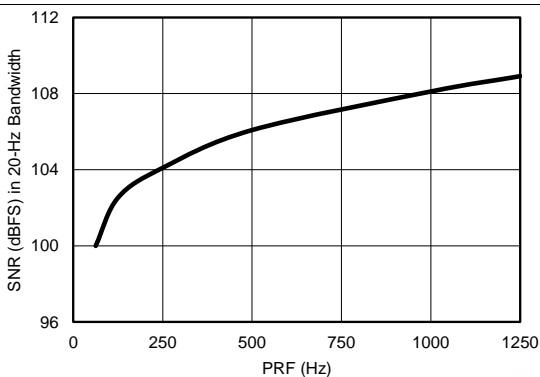

Figure 21. Receiver SNR in 20-Hz BW in Dynamic Power-Down Mode vs PRF

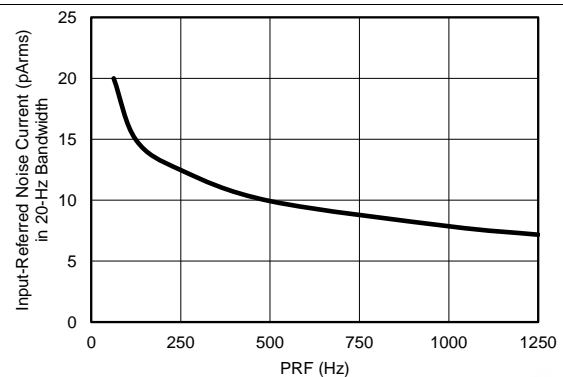

Figure 22. Receiver Input-Referred Noise in 20-Hz BW in Dynamic Power-Down Mode vs PRF

Typical Characteristics (continued)

At PRF = 100 Hz, 25% duty cycle, $R_F = 500 \text{ k}\Omega$, C_F is adjusted to keep TIA time constant at 1/10th of sampling duration, All supplies at 3.3 V, 8-MHz external clock, CLKOUT tri-state, 1- μF capacitor on TX_REF and BG pins, detector $C_{IN} = 50 \text{ pF}$, TX_REF = 0.5 V, ADC averaging = max allowed, and SNR in dBFS is noise referred to full-scale range of 2 V, unless otherwise noted.

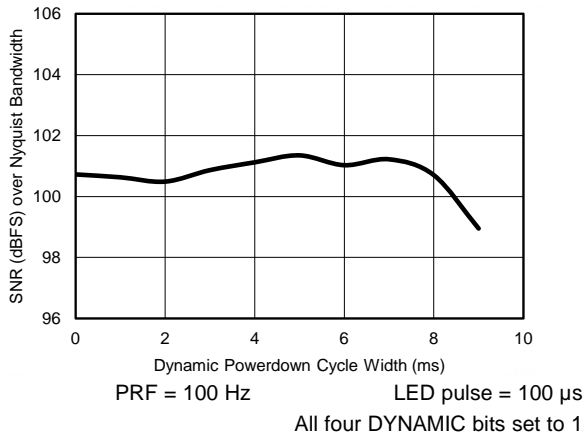

Figure 23. Receiver SNR over Nyquist Bandwidth vs Dynamic Power-Down Duty Cycle

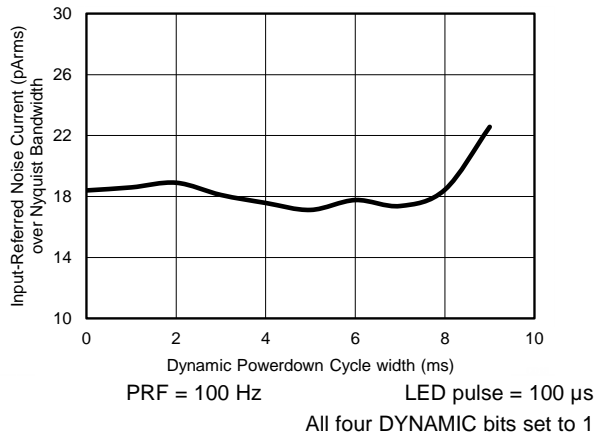

Figure 24. Receiver Input-Referred Noise over Nyquist Bandwidth vs Dynamic Power-Down Duty Cycle

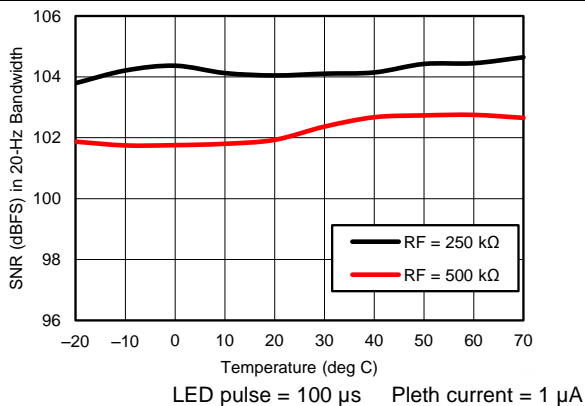

Figure 25. SNR in 20-Hz Bandwidth vs Temperature (Tx-Rx Loopback)

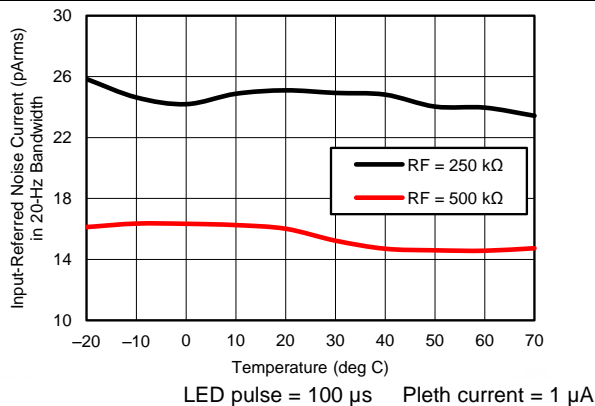

Figure 26. Input-Referred Noise Current in 20-Hz BW vs Temperature (TX-Rx Loopback)

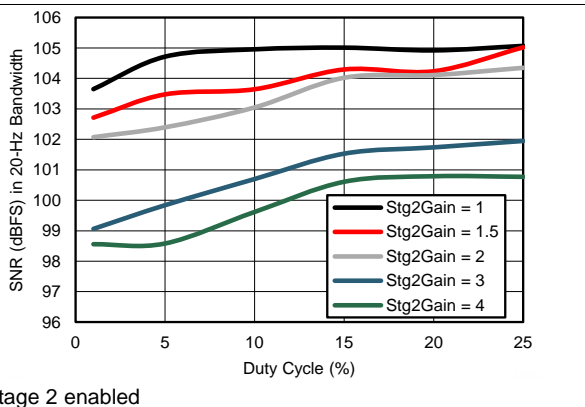

Figure 27. Receiver SNR over Nyquist Bandwidth vs Duty Cycle (Different Stage 2 Gain Settings)

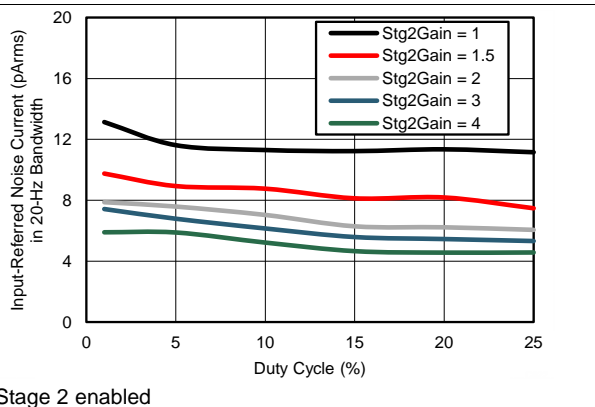

Figure 28. Receiver Input-Referred Noise Current over Nyquist Bandwidth vs Duty Cycle (Different Stage 2 Gain Settings)

Typical Characteristics (continued)

At PRF = 100 Hz, 25% duty cycle, $R_F = 500\text{ k}\Omega$, C_F is adjusted to keep TIA time constant at 1/10th of sampling duration, All supplies at 3.3 V, 8-MHz external clock, CLKOUT tri-state, 1- μF capacitor on TX_REF and BG pins, detector $C_{IN} = 50\text{ pF}$, TX_REF = 0.5 V, ADC averaging = max allowed, and SNR in dBFS is noise referred to full-scale range of 2 V, unless otherwise noted.

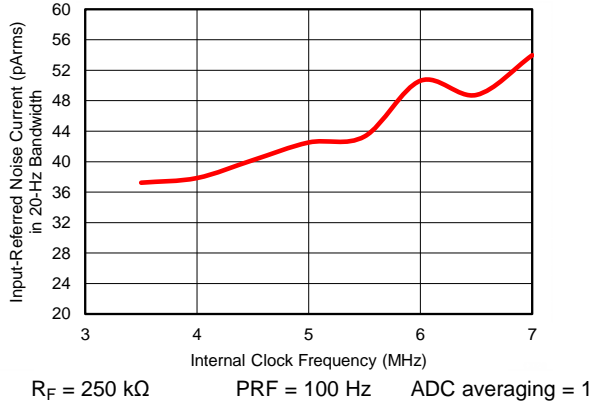

Figure 29. Receiver Input-Referred Noise Current vs Internal Clock Frequency

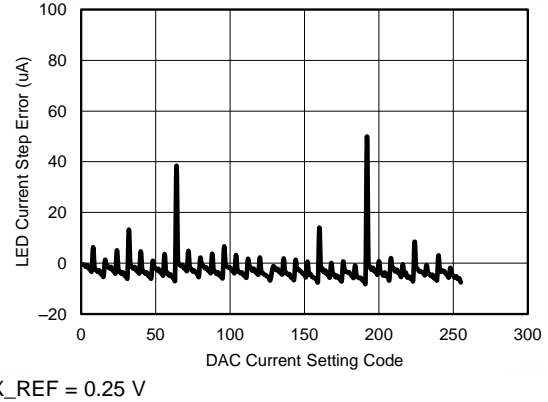

Figure 30. Transmitter DAC Current Step Error

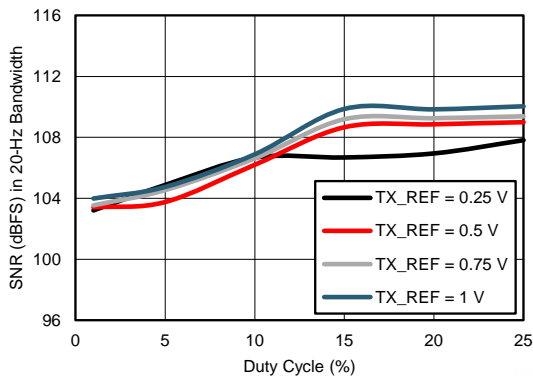

Figure 31. SNR in 20-Hz BW vs Duty Cycle (TX_REF Voltage with Tx-Rx Loopback)

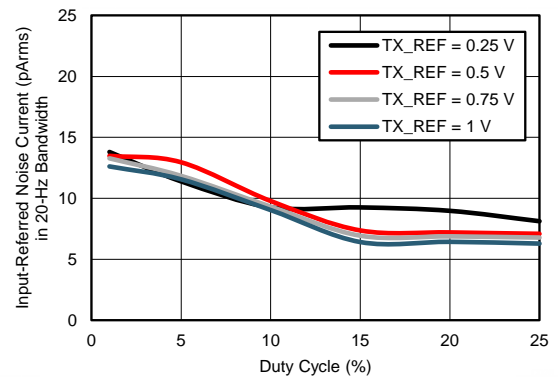

Figure 32. Input Referred Noise Current in 20-Hz BW vs Duty Cycle (TX_REF Voltage with Tx-Rx Loopback)

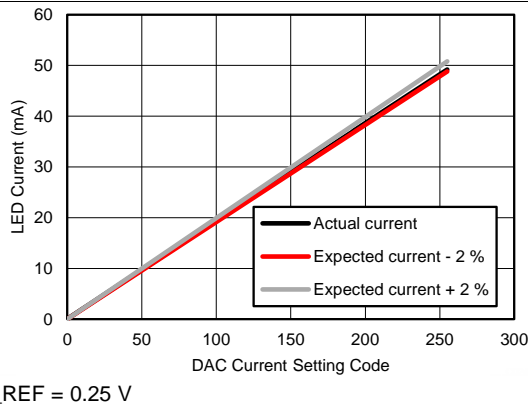

Figure 33. Transmitter Current linearity

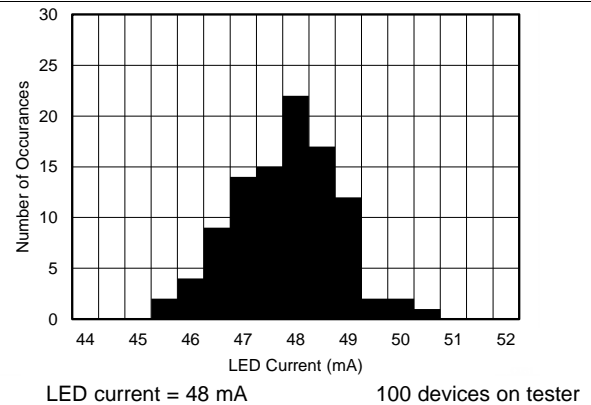

Figure 34. Transmitter Current Across Devices

Typical Characteristics (continued)

At PRF = 100 Hz, 25% duty cycle, $R_F = 500\text{ k}\Omega$, C_F is adjusted to keep TIA time constant at 1/10th of sampling duration, All supplies at 3.3 V, 8-MHz external clock, CLKOUT tri-state, 1- μF capacitor on TX_REF and BG pins, detector $C_{IN} = 50\text{ pF}$, TX_REF = 0.5 V, ADC averaging = max allowed, and SNR in dBFS is noise referred to full-scale range of 2 V, unless otherwise noted.

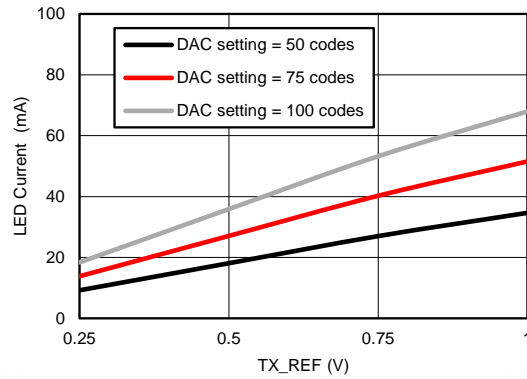

Figure 35. Transmitter Current vs TX_REF Voltage (Multiple DAC Settings)

8 Detailed Description

8.1 Overview

The AFE4403 is a complete analog front-end (AFE) solution targeted for pulse oximeter applications. The device consists of a low-noise receiver channel, an LED transmit section, and diagnostics for sensor and LED fault detection. To ease clocking requirements and provide the low-jitter clock to the AFE, an oscillator is also integrated that functions from an external crystal. The device communicates to an external microcontroller or host processor using an SPI interface. The [Functional Block Diagram](#) section provides a detailed block diagram for the AFE4403. The blocks are described in more detail in the following sections.

8.2 Functional Block Diagram

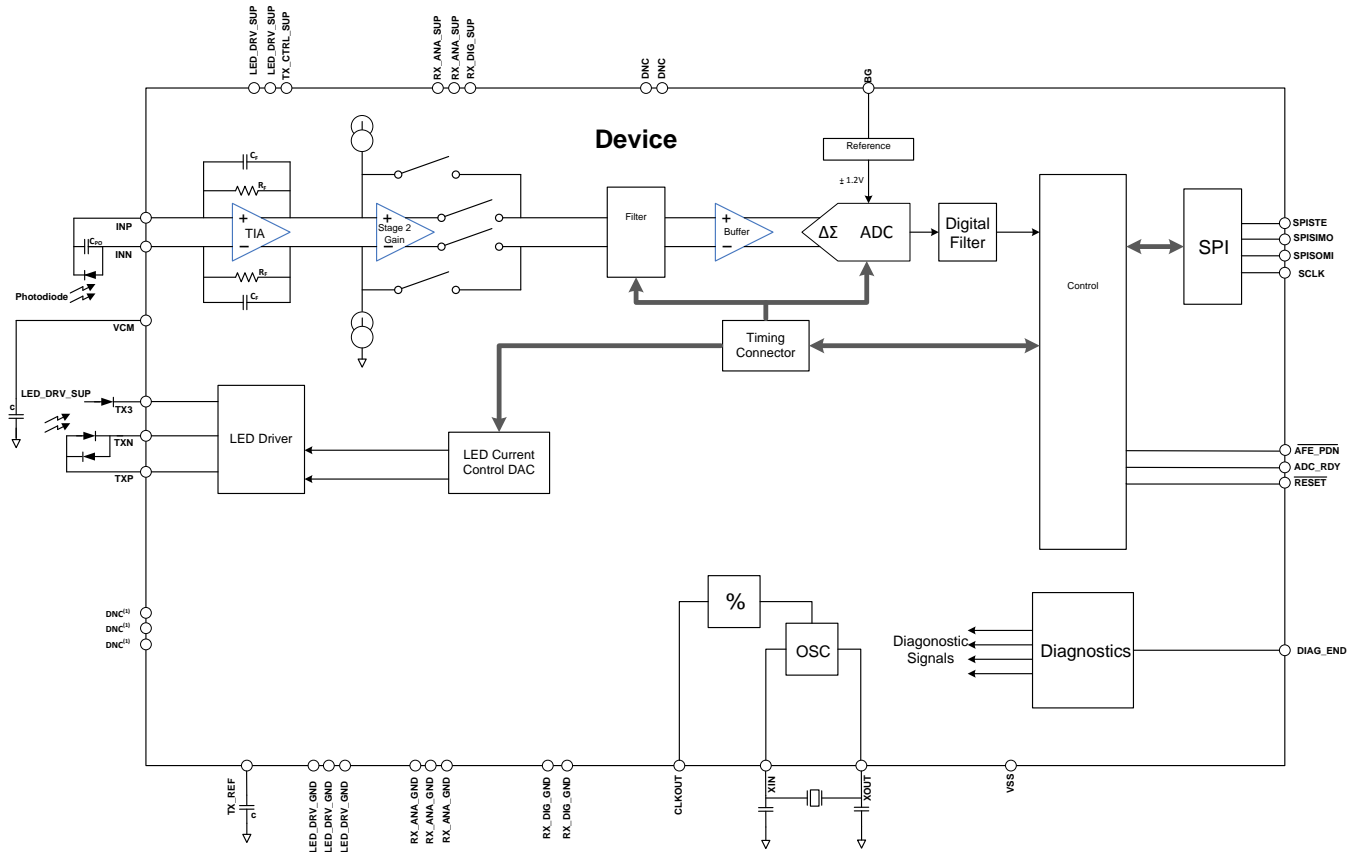

8.3 Feature Description

8.3.1 Receiver Channel

This section describes the functionality of the receiver channel.

8.3.1.1 Receiver Front-End

The receiver consists of a differential current-to-voltage (I-V) transimpedance amplifier (TIA) that converts the input photodiode current into an appropriate voltage, as shown in Figure 36. The feedback resistor of the amplifier (R_F) is programmable to support a wide range of photodiode currents. Available R_F values include: 1 M Ω , 500 k Ω , 250 k Ω , 100 k Ω , 50 k Ω , 25 k Ω , and 10 k Ω .

The device is ideally suited as a front-end for a PPG (photoplethysmography) application. In such an application, the light from the LED is reflected (or transmitted) from (or through) the various components inside the body (such as blood, tissue, and so forth) and are received by the photodiode. The signal received by the photodiode has three distinct components:

1. A pulsatile or ac component that arises as a result of the changes in blood volume through the arteries.
2. A constant dc signal that is reflected or transmitted from the time invariant components in the path of light. This constant dc component is referred to as the pleth signal.
3. Ambient light entering the photodiode.

The ac component is usually a small fraction of the pleth component, with the ratio referred to as the perfusion index (PI). Thus, the allowed signal chain gain is usually determined by the amplitude of the dc component.

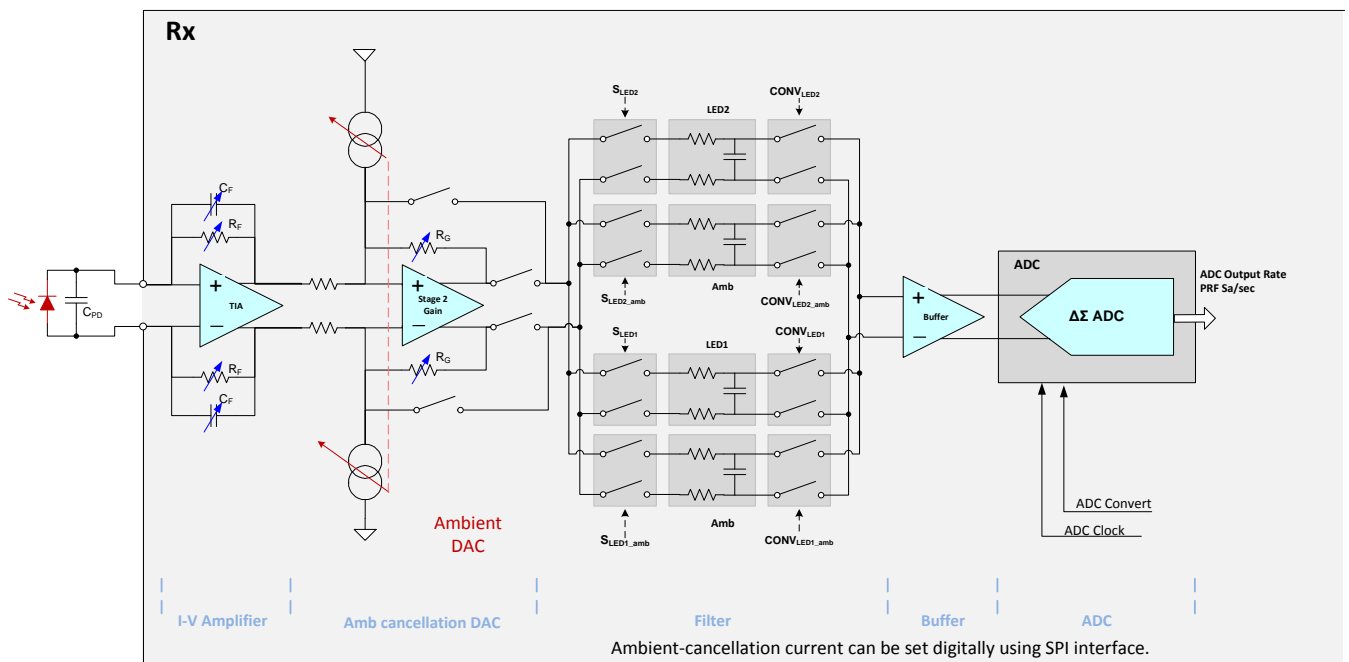

Figure 36. Receiver Front-End

The R_F amplifier and the feedback capacitor (C_F) form a low-pass filter for the input signal current. Always ensure that the low-pass filter RC time constant has sufficiently high bandwidth (as shown by Equation 1) because the input current consists of pulses. For this reason, the feedback capacitor is also programmable. Available C_F values include: 5 pF, 10 pF, 25 pF, 50 pF, 100 pF, and 250 pF. Any combination of these capacitors can also be used.

$$R_F \times C_F \leq \frac{\text{Rx Sample Time}}{10} \quad (1)$$

Feature Description (continued)

The output voltage of the I-V amplifier includes the pleth component (the desired signal) and a component resulting from the ambient light leakage. The I-V amplifier is followed by the second stage, which consists of a current digital-to-analog converter (DAC) that sources the cancellation current and an amplifier that gains up the pleth component alone. The amplifier has five programmable gain settings: 0 dB, 3.5 dB, 6 dB, 9.5 dB, and 12 dB. The gained-up pleth signal is then low-pass filtered (500-Hz bandwidth) and buffered before driving a 22-bit ADC. The current DAC has a cancellation current range of 10 μA with 10 steps (1 μA each). The DAC value can be digitally specified with the SPI interface. Using ambient compensation with the ambient DAC allows the dc-biased signal to be centered to near mid-point of the amplifier ($\pm 0.9\text{ V}$). Using the gain of the second stage allows for more of the available ADC dynamic range to be used.

The output of the ambient cancellation amplifier is separated into LED2 and LED1 channels. When LED2 is on, the amplifier output is filtered and sampled on capacitor C_{LED2} . Similarly, the LED1 signal is sampled on the C_{LED1} capacitor when LED1 is on. In between the LED2 and LED1 pulses, the idle amplifier output is sampled to estimate the ambient signal on capacitors $C_{\text{LED2_amb}}$ and $C_{\text{LED1_amb}}$.

The sampling duration is termed the *Rx sample time* and is programmable for each signal, independently. The sampling can start after the I-V amplifier output is stable (to account for LED and cable settling times). The Rx sample time is used for all dynamic range calculations; the minimum time recommended is 50 μs . While the AFE4403 can support pulse widths lower than 50 μs , having too low a pulse width could result in a degraded signal and noise from the photodiode.

A single, 22-bit ADC converts the sampled LED2, LED1, and ambient signals sequentially. Each conversion provides a single digital code at the ADC output. As discussed in the [Receiver Timing](#) section, the conversions are meant to be staggered so that the LED2 conversion starts after the end of the LED2 sample phase, and so on.

Note that four data streams are available at the ADC output (LED2, LED1, ambient LED2, and ambient LED1) at the same rate as the pulse repetition frequency. The ADC is followed by a digital ambient subtraction block that additionally outputs the (LED2 – ambient LED2) and (LED1 – ambient LED1) data values.

The model of the photodiode and the connection to the TIA is shown in [Figure 37](#).

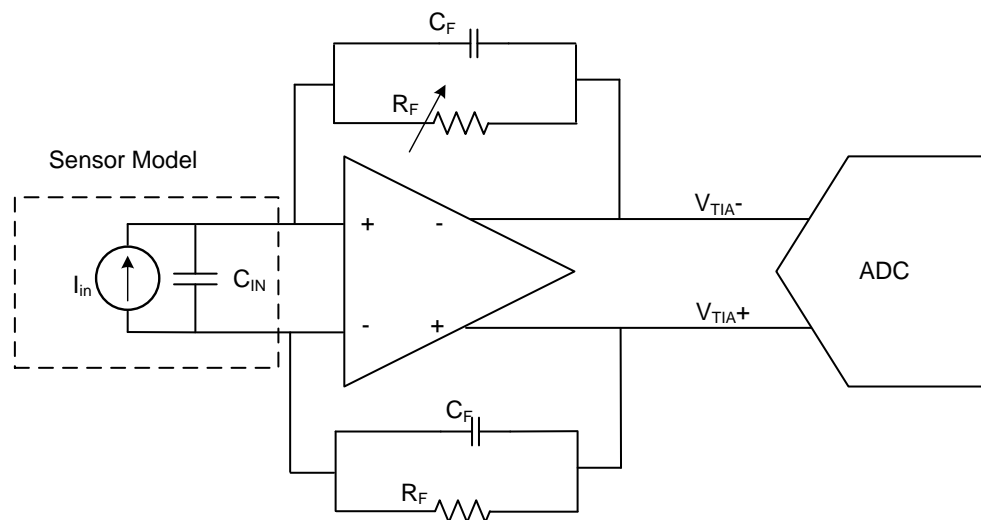

Figure 37. TIA Block Diagram

I_{in} is the signal current generated by the photodiode in response to the incident light. C_{in} is the zero-bias capacitance of the photodiode. The current-to-voltage gain in the TIA is given by [Equation 2](#):

$$V_{\text{TIA}} (\text{diff}) = V_{\text{TIA}^+} - V_{\text{TIA}^-} = 2 \times I_{\text{in}} \times R_{\text{F}} \quad (2)$$

Feature Description (continued)

For example, for a photodiode current of $I_{in} = 1 \mu A$ and a TIA gain setting of $R_F = 100 k\Omega$, the differential output of the TIA is equal to 200 mV. The TIA has an operating range of $\pm 1 V$, and the ADC has an input full-scale range of $\pm 1.2 V$ (the extra margin is to prevent the ADC from saturating while operating the TIA at the fullest output range). Furthermore, because the PPG signal is one-sided, only one half of the full-scale is used. TI recommends operating the device at a dc level that is not more than 50% to 60% of the ADC full-scale. The margin allows for sudden changes in the signal level that might saturate the signal chain if operating too close to full-scale. Signal levels are shown in [Figure 38](#):

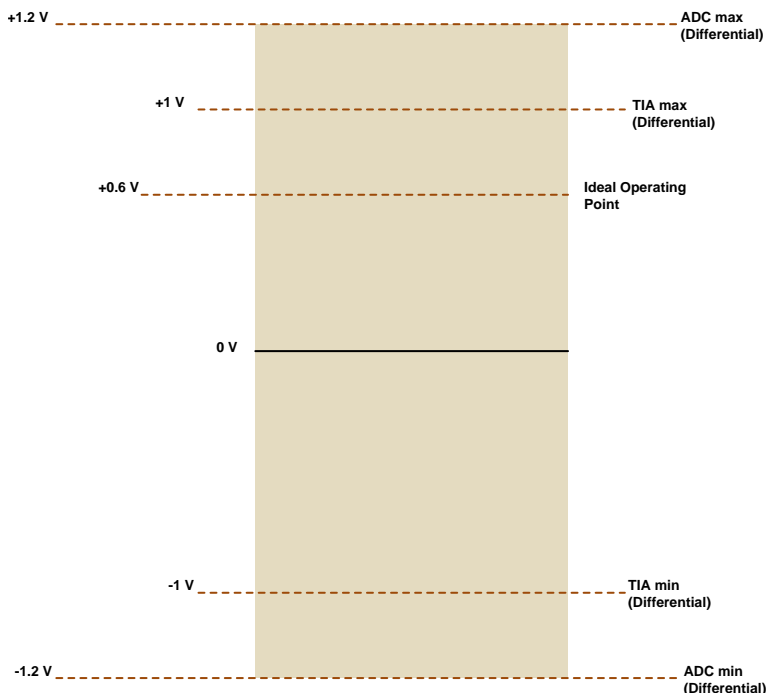

Figure 38. Signal Levels in TIA and ADC

On startup, a gain calibration algorithm running on the microcontroller unit (MCU) can be used to monitor the dc level and adjusts the LED current and TIA gain to get close to the target dc level. In addition to a target dc level, a high and low threshold (for example 80% and 20% of full-scale) can be determined that can cause the algorithm to switch to a different TIA gain or LED current setting when the signal amplitude changes beyond these thresholds.

In heart rate monitoring (HRM) applications demanding small-form factors, the sensor size can be so small (and the signal currents so low) that they do not occupy even 50% of full-scale even with the highest TIA gain setting of $1 M\Omega$, which is the case for signal currents that are less than 300 nA. As such, experimentation with various use cases is essential in order to determine the optimal target value, as well as high and low thresholds. Also, by enabling the stage 2 and introducing additional gain (up to 12 dB), a few extra decibels of SNR can be achieved.

Feature Description (continued)

8.3.1.2 Ambient Cancellation Scheme and Second Stage Gain Block

The receiver provides digital samples corresponding to ambient duration. The host processor (external to the AFE) can use these ambient values to estimate the amount of ambient light leakage. The processor must then set the value of the ambient cancellation DAC using the SPI, as shown in Figure 39.

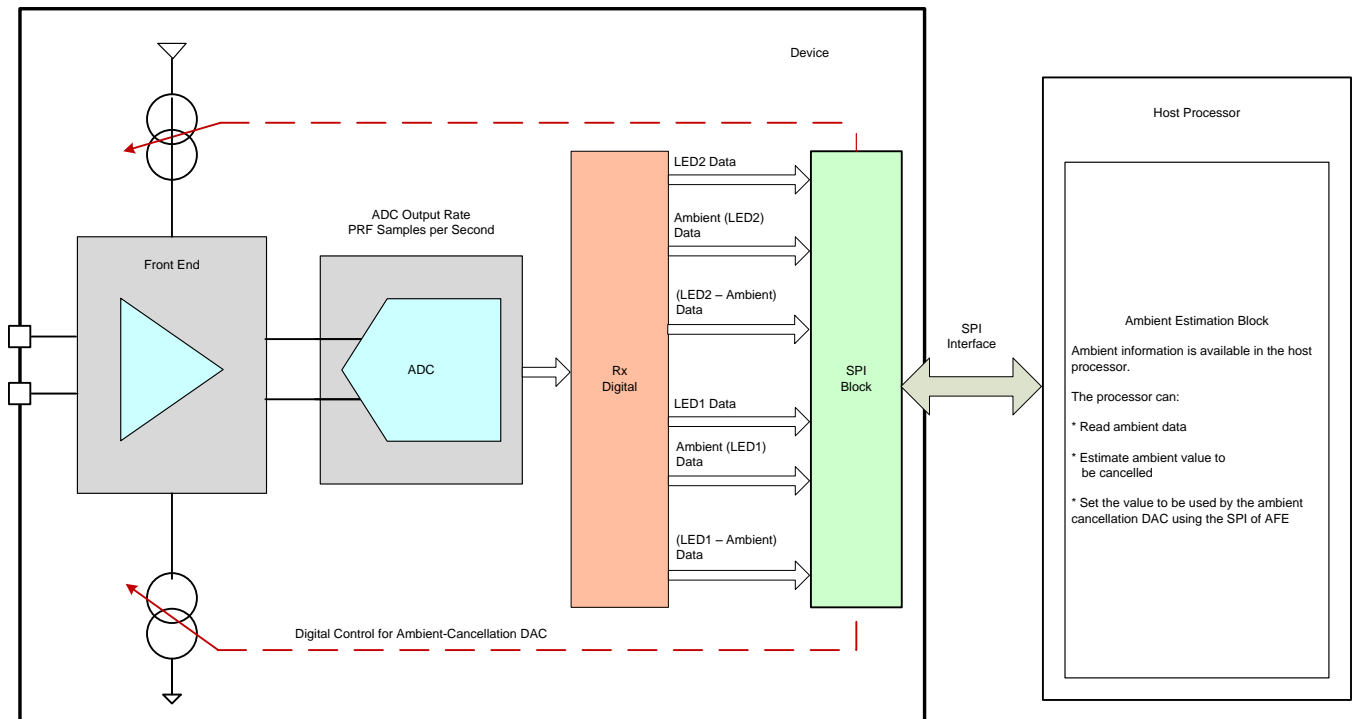

Figure 39. Ambient Cancellation Loop (Closed by the Host Processor)

Feature Description (continued)

Using the set value, the ambient cancellation stage subtracts the ambient component and gains up only the pleth component of the received signal; see Figure 40. The amplifier gain is programmable to 0 dB, 3.5 dB, 6 dB, 9.5 dB, and 12 dB.

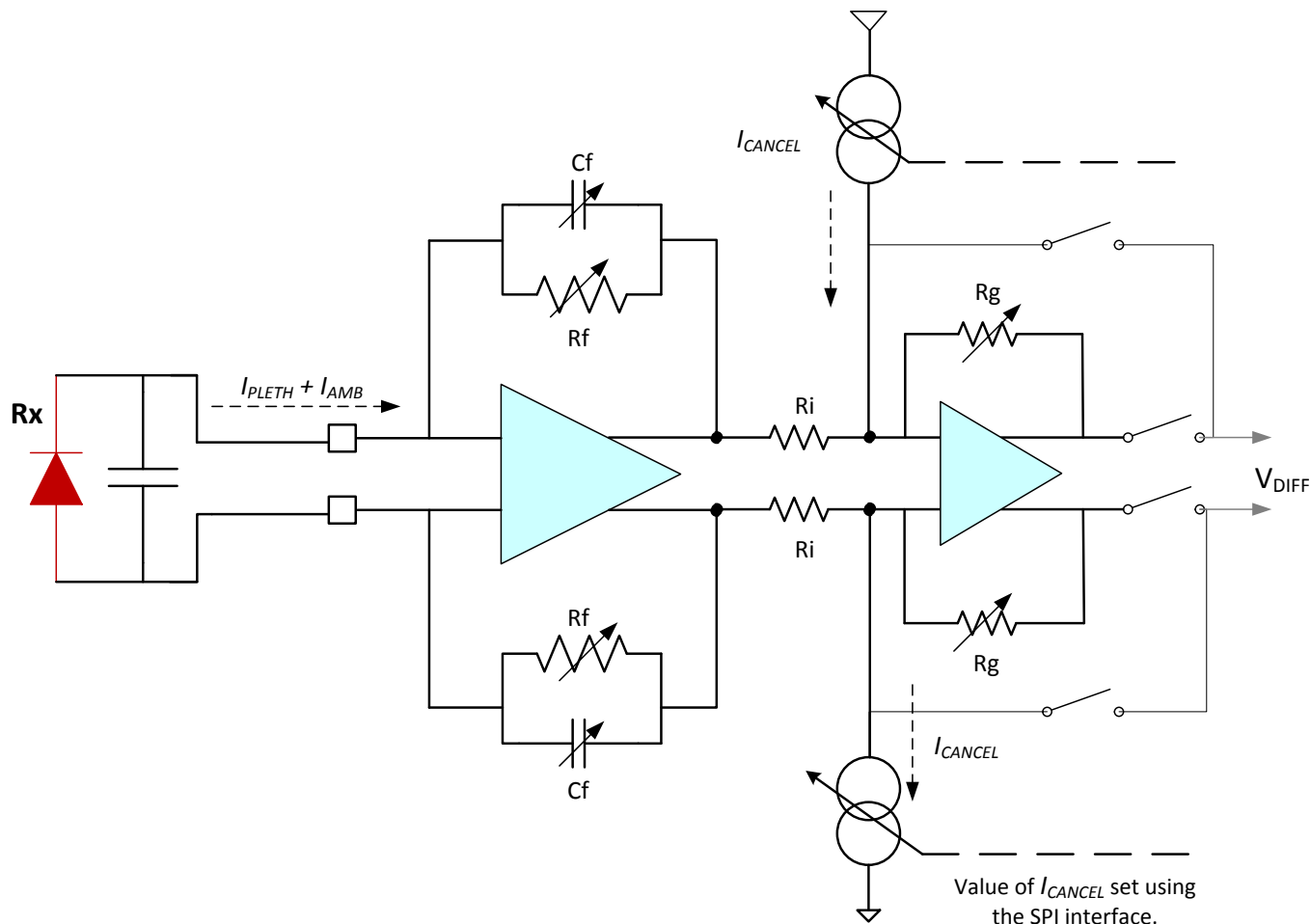

Figure 40. Front-End (I-V Amplifier and Cancellation Stage)

Feature Description (continued)

The differential output of the second stage is V_{DIFF} , as given by [Equation 3](#):

$$V_{DIFF} = 2 \times \left[I_{PLETH} \times \frac{R_F}{R_I} + I_{AMB} \times \frac{R_F}{R_I} - I_{CANCEL} \right] \times R_G$$

where:

- $R_I = 100 \text{ k}\Omega$,
- I_{PLETH} = photodiode current pleth component,
- I_{AMB} = photodiode current ambient component, and
- I_{CANCEL} = the cancellation current DAC value (as estimated by the host processor). (3)

R_G values with various gain settings are listed in [Table 1](#).

Table 1. R_G Values

GAIN	$R_G(\text{k}\Omega)$
0 (x1)	100
3.5 (x1.5)	150
6 (x2)	200
9.5 (x3)	300
12 (x4)	400

8.3.1.3 Receiver Control Signals

LED2 sample phase (S_{LED2} or S_R): When this signal is high, the amplifier output corresponds to the LED2 on-time. The amplifier output is filtered and sampled into capacitor C_{LED2} . To avoid settling effects resulting from the LED or cable, program S_{LED2} to start after the LED turns on. This settling delay is programmable.

Ambient sample phase (S_{LED2_amb} or S_{R_amb}): When this signal is high, the amplifier output corresponds to the LED2 off-time and can be used to estimate the ambient signal (for the LED2 phase). The amplifier output is filtered and sampled into capacitor C_{LED2_amb} .

LED1 sample phase (S_{LED1} or S_{IR}): When this signal is high, the amplifier output corresponds to the LED1 on-time. The amplifier output is filtered and sampled into capacitor C_{LED1} . To avoid settling effects resulting from the LED or cable, program S_{LED1} to start after the LED turns on. This settling delay is programmable.

Ambient sample phase (S_{LED1_amb} or S_{IR_amb}): When this signal is high, the amplifier output corresponds to the LED1 off-time and can be used to estimate the ambient signal (for the LED1 phase). The amplifier output is filtered and sampled into capacitor C_{LED1_amb} .

LED2 convert phase ($CONV_{LED2}$ or $CONV_R$): When this signal is high, the voltage sampled on C_{LED2} is buffered and applied to the ADC for conversion. At the end of the conversion, the ADC provides a single digital code corresponding to the LED2 sample.

Ambient convert phases ($CONV_{LED2_amb}$ or $CONV_{R_amb}$, $CONV_{LED1_amb}$ or $CONV_{IR_amb}$): When this signal is high, the voltage sampled on C_{LED2_amb} (or C_{LED1_amb}) is buffered and applied to the ADC for conversion. At the end of the conversion, the ADC provides a single digital code corresponding to the ambient sample.

LED1 convert phase ($CONV_{LED1}$ or $CONV_{IR}$): When this signal is high, the voltage sampled on C_{LED1} is buffered and applied to the ADC for conversion. At the end of the conversion, the ADC provides a single digital code corresponding to the LED1 sample.

8.3.1.4 Receiver Timing

See [Figure 41](#) for a timing diagram detailing the control signals related to the LED on-time, Rx sample time, and the ADC conversion times for each channel. [Figure 41](#) shows the timing for a case where each phase occupies 25% of the pulse repetition period. However, this percentage is not a requirement. In cases where the device is operated with low pulse repetition frequency (PRF) or low LED pulse durations, the active portion of the pulse repetition period can be reduced. Using the dynamic power-down feature, the overall power consumption can be significantly reduced.

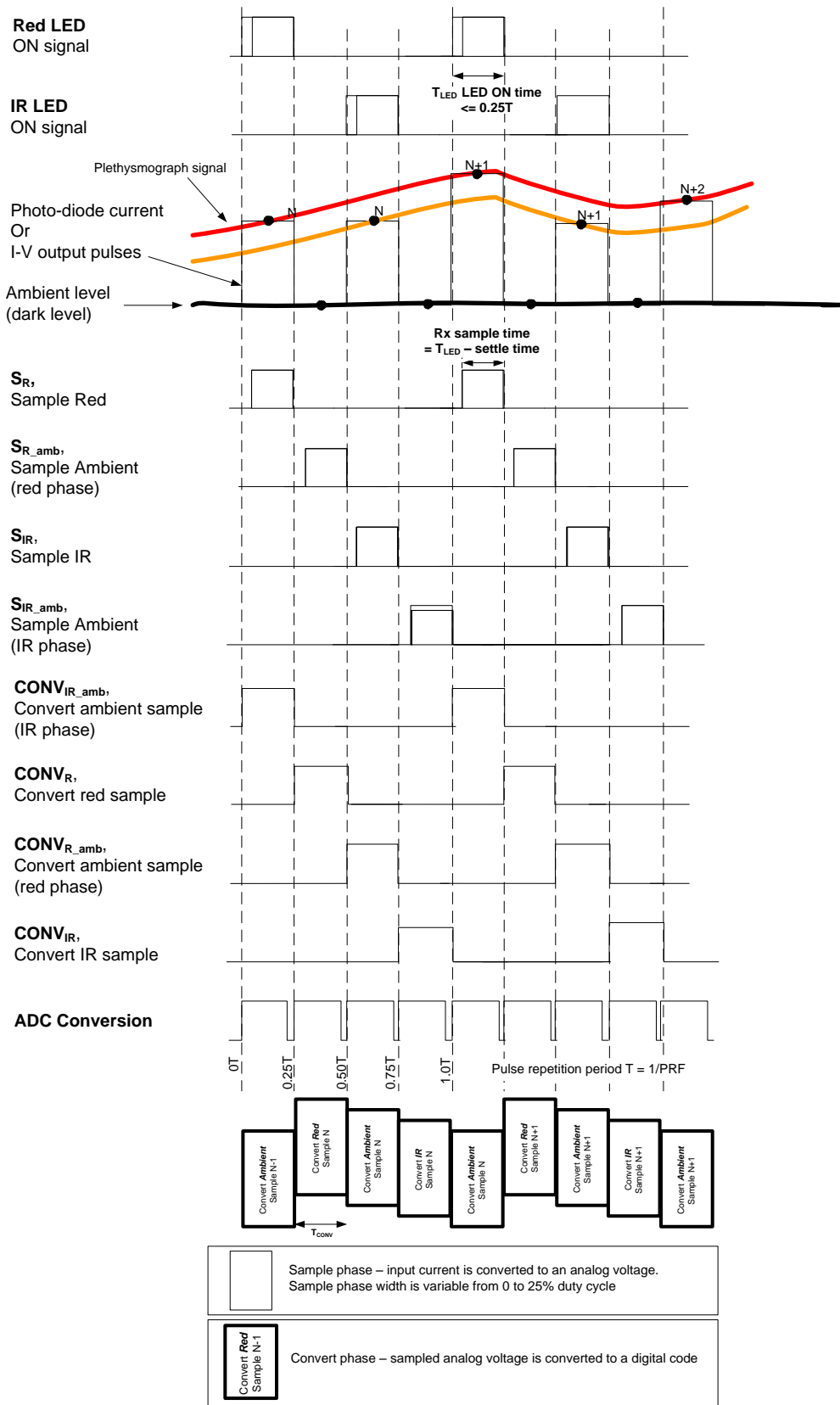

NOTE: Relationship to the AFE4403 EVM is: LED1 = IR and LED2 = RED.

Figure 41. Rx Timing Diagram

8.3.2 Clocking and Timing Signal Generation

The crystal oscillator generates a master clock signal using an external crystal. In the default mode, a divide-by-2 block converts the 8-MHz clock to 4 MHz, which is used by the AFE to operate the timer modules, ADC, and diagnostics. The 4-MHz clock is buffered and output from the AFE in order to clock an external microcontroller. The clocking functionality is shown in [Figure 42](#).

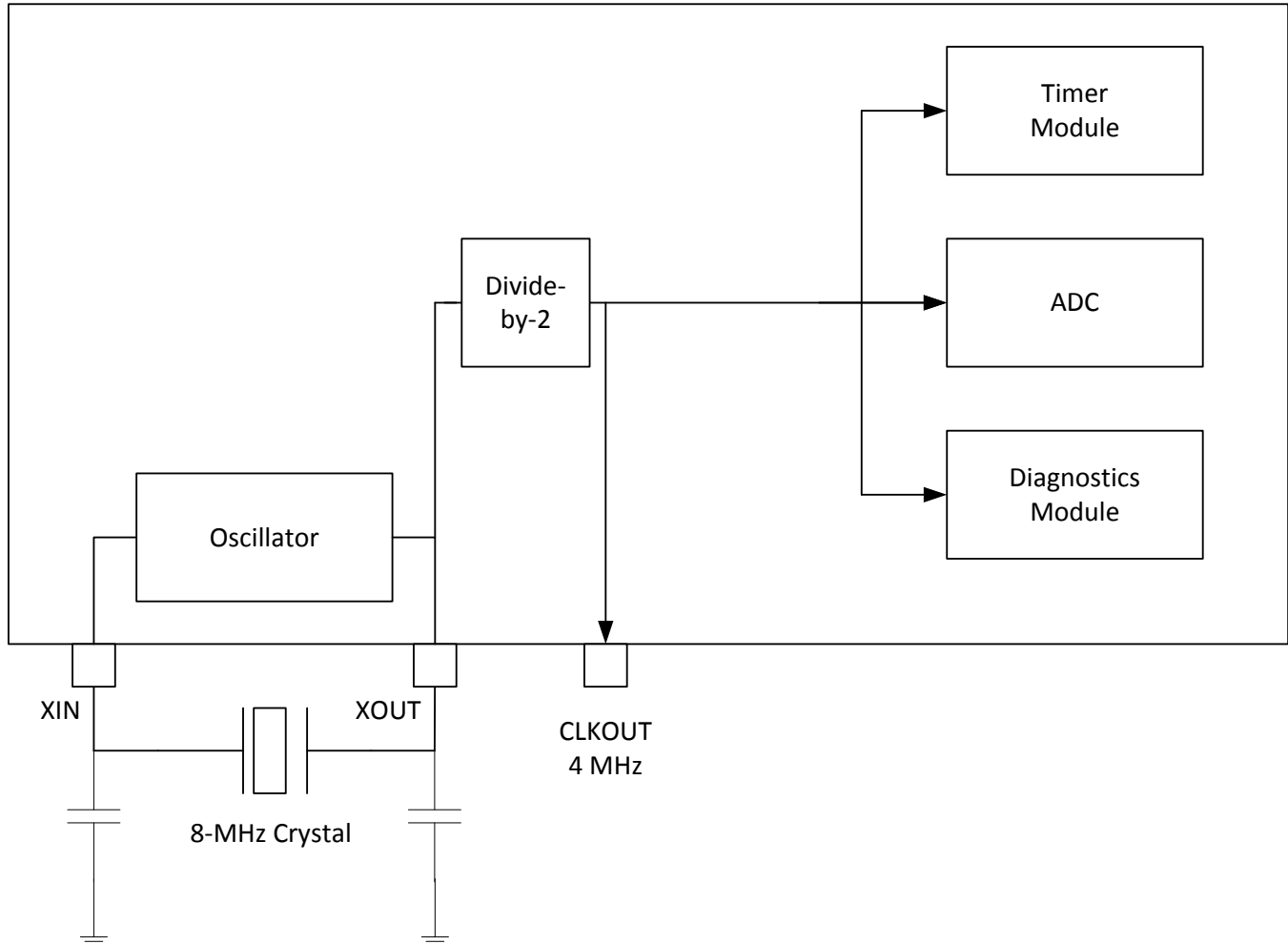

Figure 42. AFE Clocking

To enable flexible clocking, the AFE4403 has a clock divider with programmable division ratios. While the default division ratio is divide-by-2, the clock divider can be programmed to select between ratios of 1, 2, 4, 6, 8, or 12. The division ratio should be selected based on the external clock input frequency such that the divided clock has a frequency close to 4 MHz. For this reason, CLKOUT is referred to as a 4-MHz clock in this document. When operating with an external clock input, the divider is reset based on the RESET rising edge. Figure 43 shows the case where the divider ratio is set to divide-by-2.

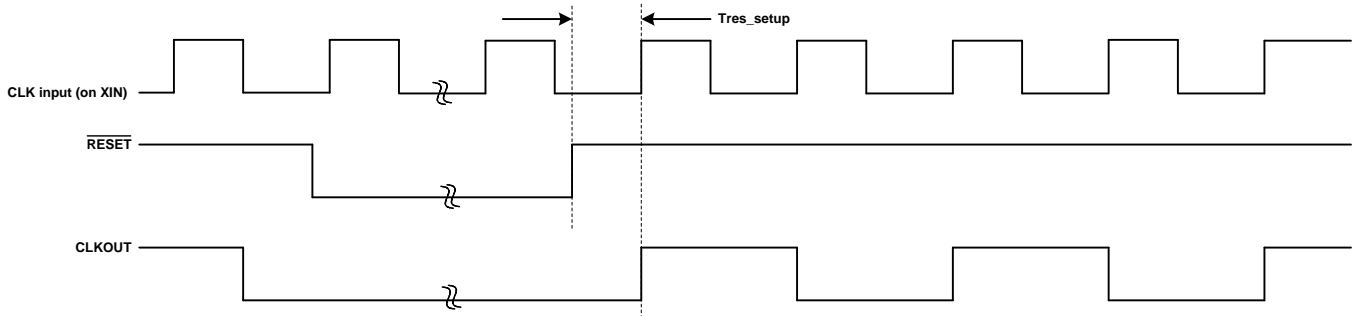

Figure 43. Clock Divider Reset

The device supports both external clock mode as well as an internal clock mode with external crystal.

In the external clock mode, an external clock is input on the XIN pin and the device internally generates the internal clock (used by the timing engine and the ADC) by a programmable division ratio. After division, the internal clock should be within a range of 4 MHz to 6 MHz. The exact frequency of this divided clock is one of the pieces of information required to establish the heart rate being measured from the pulse data.

In internal clock mode, an external crystal (connected between XIN and XOUT) is used to generate the clock. To generate sustained oscillations, the oscillator within the AFE provides negative resistance to cancel out the ESR of the crystal. A good rule of thumb is to limit the ESR of the crystal to less than a third of the negative resistance achievable by the oscillator. Figure 44 shows the connection of Crystal to AFE4403.

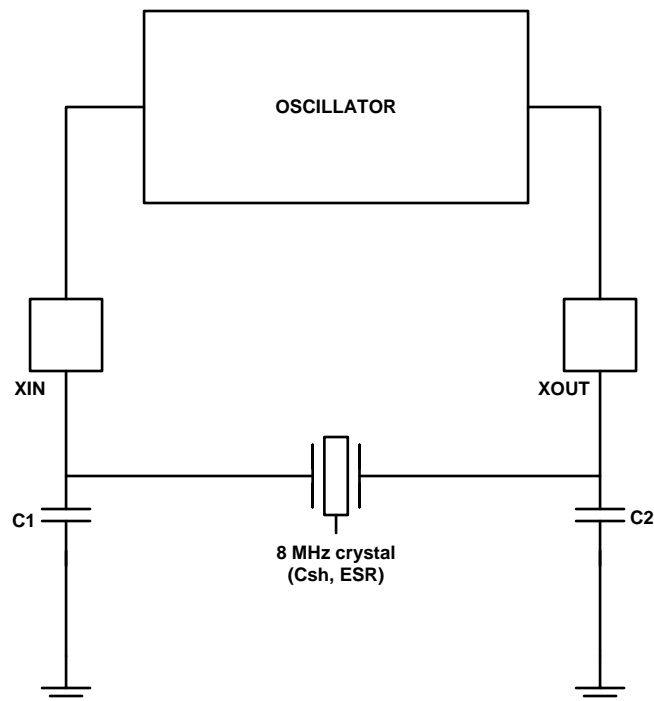

Figure 44. Connection of Crystal to AFE4403

In [Figure 44](#) the crystal is characterized by a capacitance, C_{sh} (shunt capacitance of the crystal) and an equivalent series resistance (ESR). C1 and C2 are external capacitors added at the XIN and XOUT pins.

The negative resistance achievable from the internal oscillator is given by [Equation 4](#):

$$R = -1 / (2 \times \omega \times C_{sh} \times [1 + C_{sh} / C_L])$$

where

- $C_L = (C1 \times C2) / (C1 + C2)$,
- ω is the frequency of oscillation in rads,
- C_{sh} is the shunt capacitor of the crystal, and
- C1, C2 are the capacitors to ground from the XIN, XOUT pins. A value of approximately 15 pF is recommended for C1, C2. (4)

For example, with $C_{sh} = 8$ pF, $C1 = C2 = 15$ pF, and a frequency of 8 MHz, the result is [Equation 5](#):

$$R = -600 \Omega \quad (5)$$

Thus, the crystal ESR is limited to less than approximately 200 Ω .

TI highly recommends that a single clock source be used to generate the clock required by the AFE as well as the clock needed by the microcontroller (MCU). If an independent clock source is used by the MCU, then any energy coupling into the AFE supply or ground or input pins can cause aliased spurious tones close to the heart rate being measured. To enable operation with the single clock source between the AFE and the MCU, two options are possible:

1. **AFE clock as master:** The AFE uses a crystal to generate its clock. CLKOUT from the AFE is used as the input clock for the MCU.
2. **MCU clock as master:** The AFE operates with an external clock provided by the MCU.

Note that the switching of CLKOUT consumes power. Thus, if CLKOUT is not used, it can be shut off using the CLKOUT_TRI bit.

8.3.3 Timer Module

See [Figure 45](#) for a timing diagram detailing the various timing edges that are programmable using the timer module. The rising and falling edge positions of 11 signals can be controlled. The module uses a single 16-bit counter (running off of the 4-MHz clock) to set the time-base.

All timing signals are set with reference to the pulse repetition period (PRP). Therefore, a dedicated compare register compares the 16-bit counter value with the reference value specified in the PRF register. Every time that the 16-bit counter value is equal to the reference value in the PRF register, the counter is reset to 0.

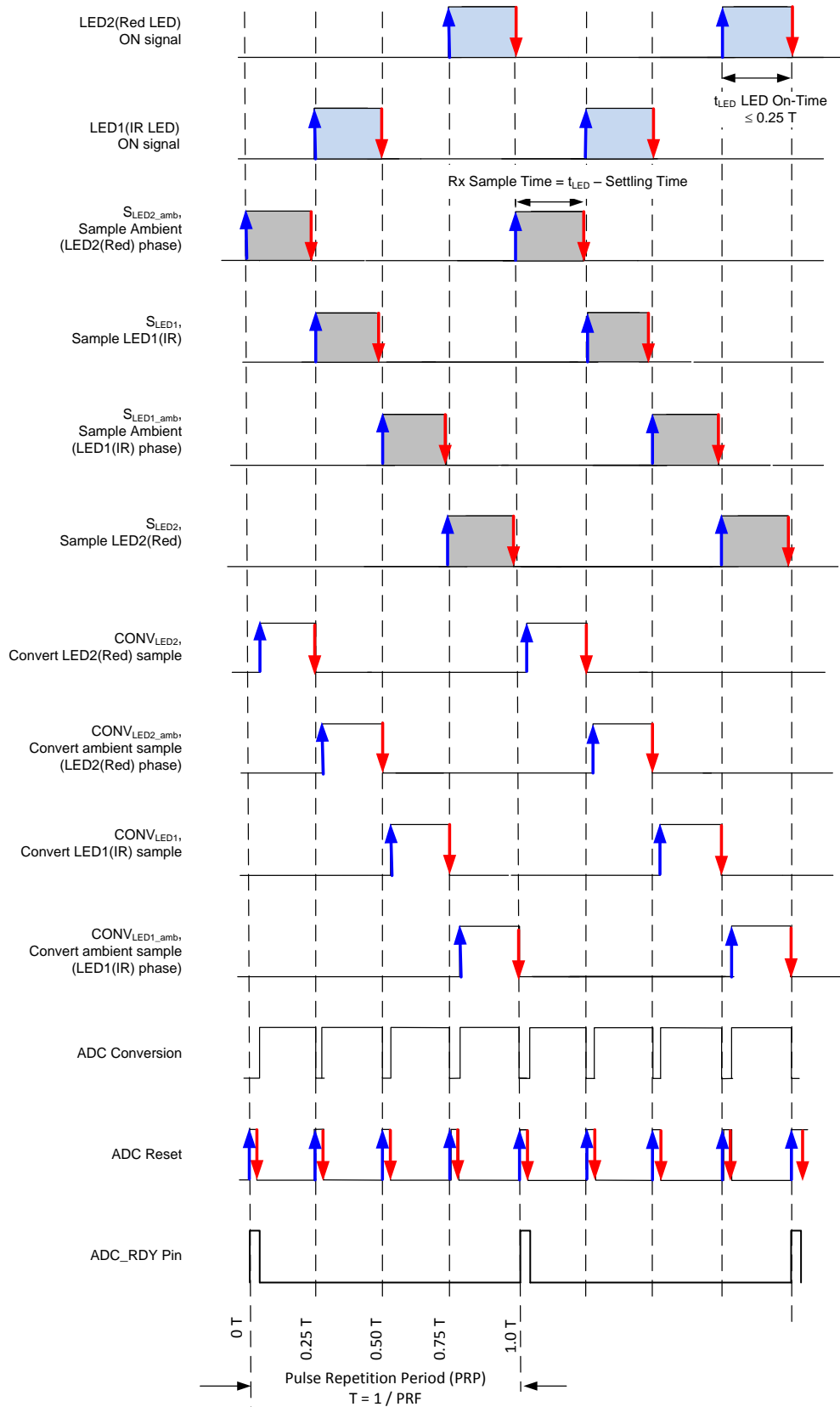

NOTE: Programmable edges are shown in blue and red.

Figure 45. AFE Control Signals

For the timing signals in Figure 41, the start and stop edge positions are programmable with respect to the PRF period. Each signal uses a separate timer compare module that compares the counter value with preprogrammed reference values for the start and stop edges. All reference values can be set using the SPI interface.

After the counter value has exceeded the stop reference value, the output signal is set. When the counter value equals the stop reference value, the output signal is reset. Figure 46 shows a diagram of the timer compare register. With a 4-MHz clock, the edge placement resolution is 0.25 μ s.

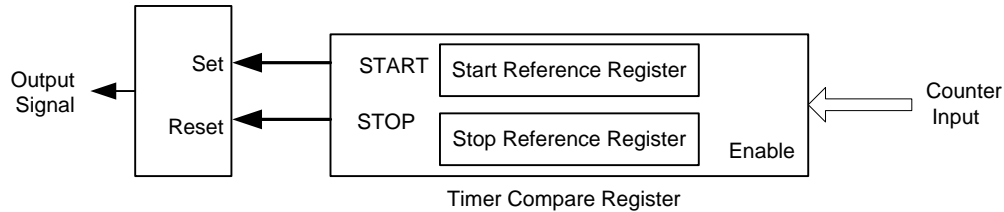

Figure 46. Compare Register

The ADC conversion signal requires four pulses in each PRF clock period. Timer compare register 11 uses four sets of start and stop registers to control the ADC conversion signal, as shown in Figure 47.

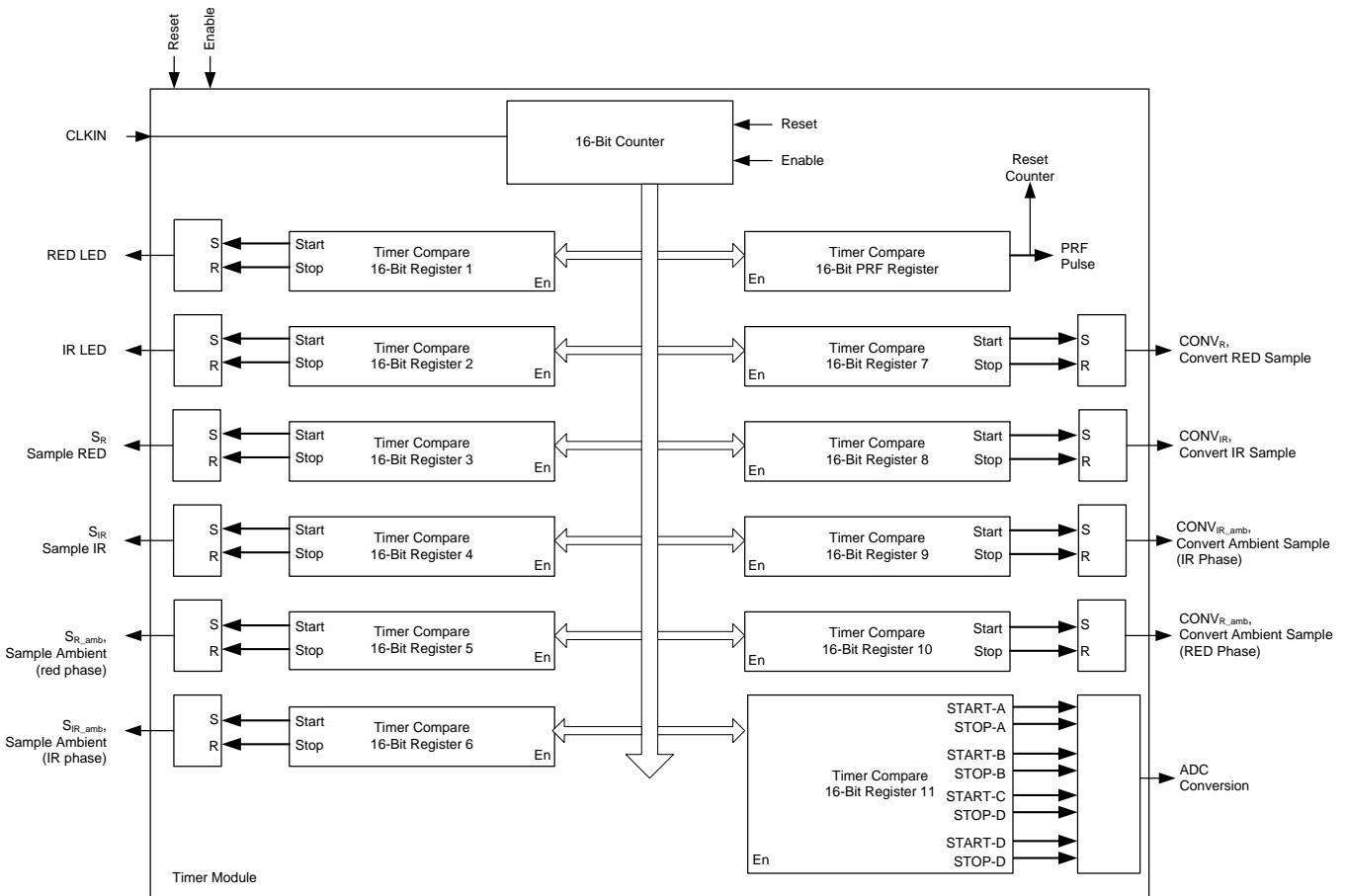

Figure 47. Timer Module

8.3.3.1 Using the Timer Module

The timer module registers can be used to program the start and end instants in units of 4-MHz clock cycles. These timing instants and the corresponding registers are listed in Table 2.

Note that the device does not restrict the values in these registers; thus, the start and end edges can be positioned anywhere within the pulse repetition period. Care must be taken by the user to program suitable values in these registers to avoid overlapping the signals and to make sure none of the edges exceed the value programmed in the PRP register. Writing the same value in the start and end registers results in a pulse duration of one clock cycle. The following steps describe the timer sequencing configuration:

1. With respect to the start of the PRP period (indicated by timing instant t_0 in [Figure 48](#)), the following sequence of conversions must be followed in order: convert LED2 → LED2 ambient → LED1 → LED1 ambient.
2. Also, starting from t_0 , the sequence of sampling instants must be staggered with respect to the respective conversions as follows: sample LED2 ambient → LED1 → LED1 ambient → LED2.
3. Finally, align the edges for the two LED pulses with the respective sampling instants.

Table 2. Clock Edge Mapping to SPI Registers

TIME INSTANT (See Figure 48 and Figure 49) ⁽¹⁾	DESCRIPTION	CORRESPONDING REGISTER ADDRESS AND REGISTER BITS	EXAMPLE ⁽²⁾ (Decimal)
t_0	Start of pulse repetition period	No register control	—
t_1	Start of sample LED2 pulse	LED2STC[15:0], register 01h	6050
t_2	End of sample LED2 pulse	LED2ENDC[15:0], register 02h	7998
t_3	Start of LED2 pulse	LED2LEDSTC[15:0], register 03h	6000
t_4	End of LED2 pulse	LED2LEDENDC[15:0], register 04h	7999
t_5	Start of sample LED2 ambient pulse	ALED2STC[15:0], register 05h	50
t_6	End of sample LED2 ambient pulse	ALED2ENDC[15:0], register 06h	1998
t_7	Start of sample LED1 pulse	LED1STC[15:0], register 07h	2050
t_8	End of sample LED1 pulse	LED1ENDC[15:0], register 08h	3998
t_9	Start of LED1 pulse	LED1LEDSTC[15:0], register 09h	2000
t_{10}	End of LED1 pulse	LED1LEDENDC[15:0], register 0Ah	3999
t_{11}	Start of sample LED1 ambient pulse	ALED1STC[15:0], register 0Bh	4050
t_{12}	End of sample LED1 ambient pulse	ALED1ENDC[15:0], register 0Ch	5998
t_{13}	Start of convert LED2 pulse	LED2CONVST[15:0], register 0Dh Must start one AFE clock cycle after the ADC reset pulse ends.	4
t_{14}	End of convert LED2 pulse	LED2CONVEND[15:0], register 0Eh	1999
t_{15}	Start of convert LED2 ambient pulse	ALED2CONVST[15:0], register 0Fh Must start one AFE clock cycle after the ADC reset pulse ends.	2004
t_{16}	End of convert LED2 ambient pulse	ALED2CONVEND[15:0], register 10h	3999
t_{17}	Start of convert LED1 pulse	LED1CONVST[15:0], register 11h Must start one AFE clock cycle after the ADC reset pulse ends.	4004
t_{18}	End of convert LED1 pulse	LED1CONVEND[15:0], register 12h	5999
t_{19}	Start of convert LED1 ambient pulse	ALED1CONVST[15:0], register 13h Must start one AFE clock cycle after the ADC reset pulse ends.	6004
t_{20}	End of convert LED1 ambient pulse	ALED1CONVEND[15:0], register 14h	7999
t_{21}	Start of first ADC conversion reset pulse	ADCRSTSTCT0[15:0], register 15h	0
t_{22}	End of first ADC conversion reset pulse ⁽³⁾	ADCRSTENDCT0[15:0], register 16h	3
t_{23}	Start of second ADC conversion reset pulse	ADCRSTSTCT1[15:0], register 17h	2000
t_{24}	End of second ADC conversion reset pulse ⁽³⁾	ADCRSTENDCT1[15:0], register 18h	2003
t_{25}	Start of third ADC conversion reset pulse	ADCRSTSTCT2[15:0], register 19h	4000
t_{26}	End of third ADC conversion reset pulse ⁽³⁾	ADCRSTENDCT2[15:0], register 1Ah	4003
t_{27}	Start of fourth ADC conversion reset pulse	ADCRSTSTCT3[15:0], register 1Bh	6000
t_{28}	End of fourth ADC conversion reset pulse ⁽³⁾	ADCRSTENDCT3[15:0], register 1Ch	6003
t_{29}	End of pulse repetition period	PRPCOUNT[15:0], register 1Dh	7999

(1) Any pulse can be set to zero width by making its start value higher than the end value.

(2) Values are based off of a pulse repetition frequency (PRF) = 500 Hz and duty cycle = 25%.

(3) See [Figure 49](#), note 2 for the effect of the ADC reset time crosstalk.

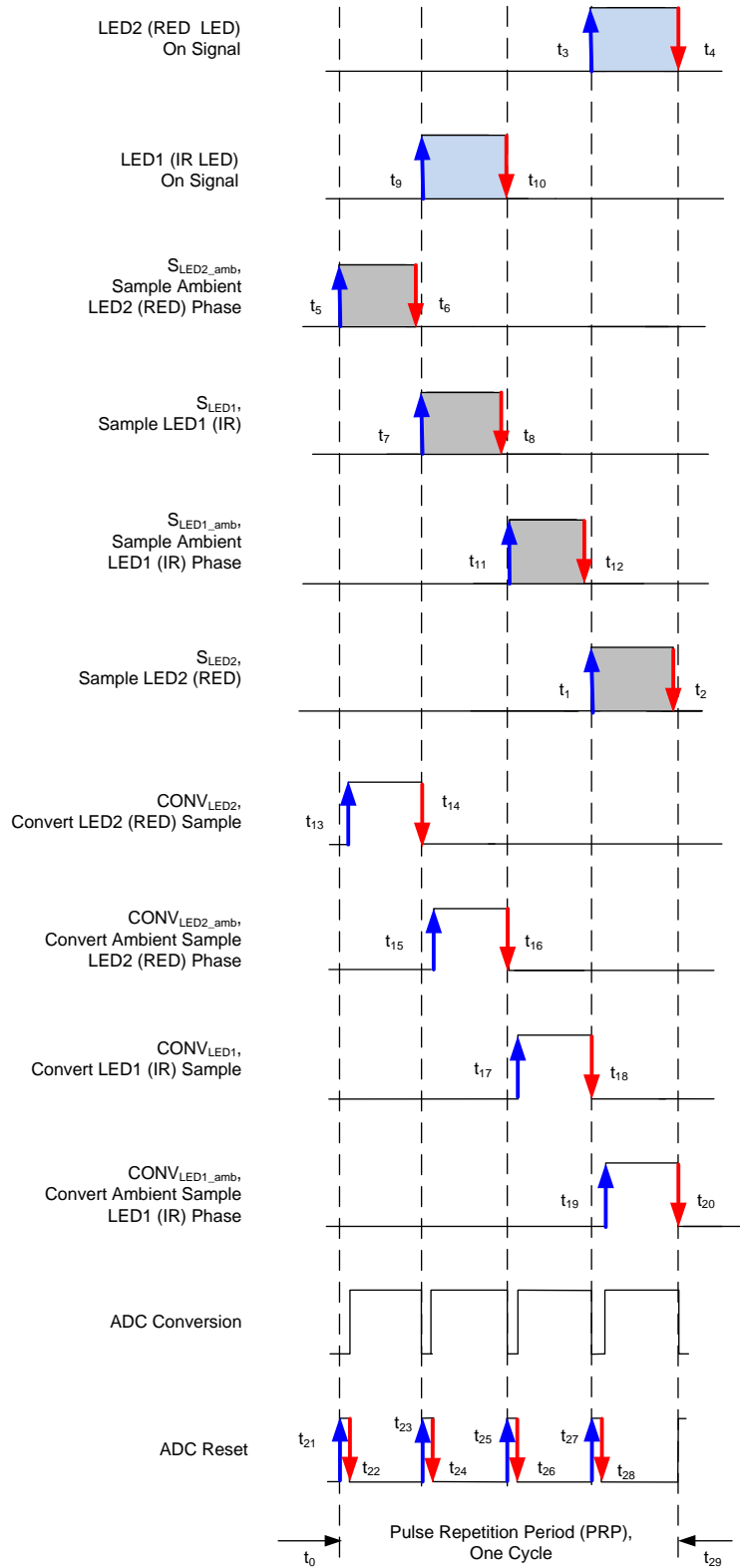

(1) RED = LED2, IR = LED1.

(2) A low ADC reset time can result in a small component of the LED signal leaking into the ambient phase. With an ADC reset of two clock cycles, a -60-dB leakage is expected. In many cases, this leakage does not affect system performance. However, if this crosstalk must be completely eliminated, a longer ADC reset time of approximately six clock cycles is recommended for t_{22} , t_{24} , t_{26} , and t_{28} .

Figure 48. Programmable Clock Edges⁽¹⁾⁽²⁾

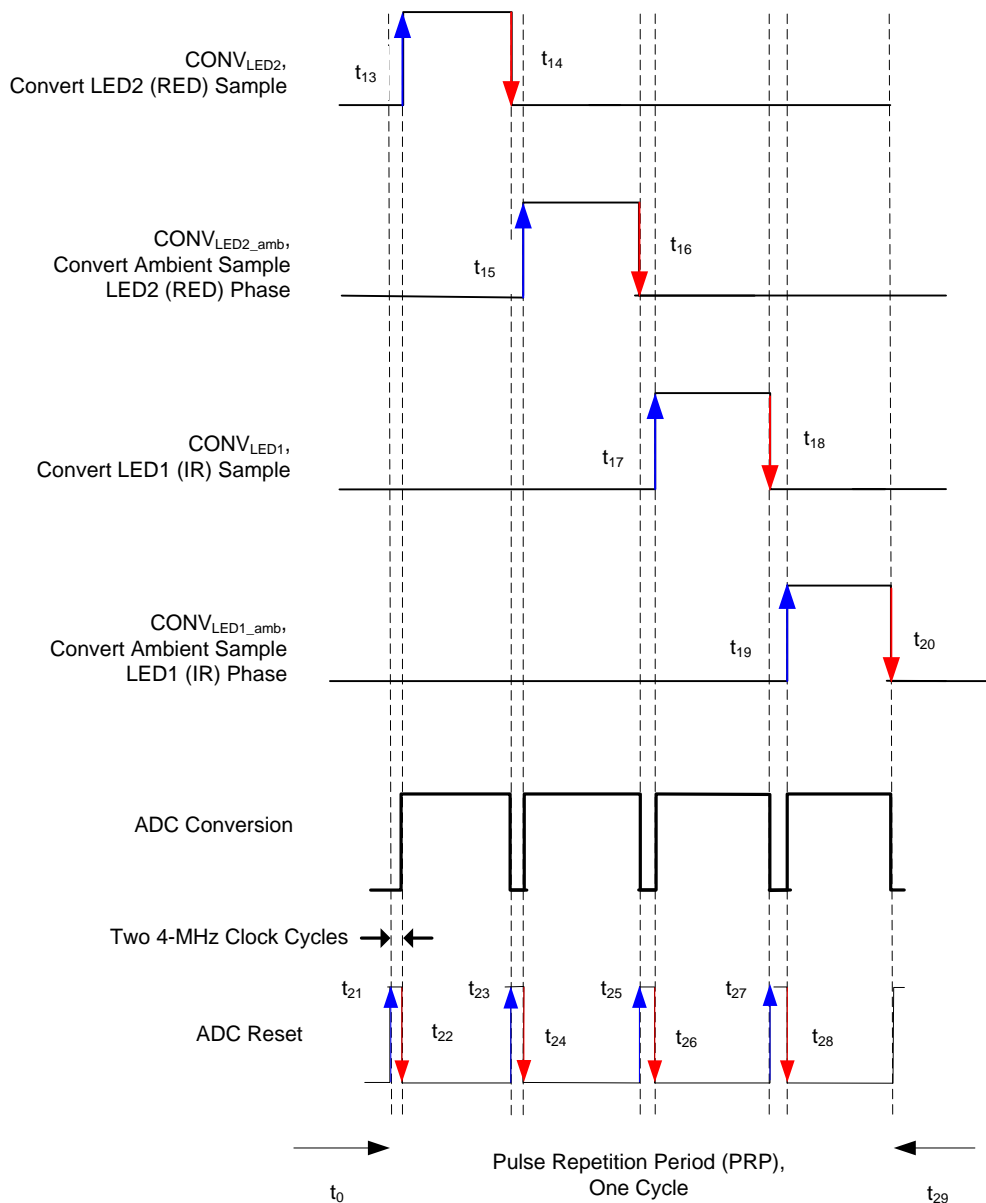

(1) RED = LED2, IR = LED1.

(2) A low ADC reset time can result in a small component of the LED signal leaking into the ambient phase. With an ADC reset of two clock cycles, a -60-dB leakage is expected. In many cases, this leakage does not affect system performance. However, if this crosstalk must be completely eliminated, a longer ADC reset time of approximately six clock cycles is recommended for t_{22} , t_{24} , t_{26} , and t_{28} .

Figure 49. Relationship Between the ADC Reset and ADC Conversion Signals⁽¹⁾⁽²⁾

8.3.4 Receiver Subsystem Power Path

The block diagram in [Figure 50](#) shows the AFE4403 Rx subsystem power routing. Internal LDOs running off RX_ANA_SUP and RX_DIG_SUP generate the 1.8-V supplies required to drive the internal blocks. The two receive supplies could be shorted to a single supply on the board.

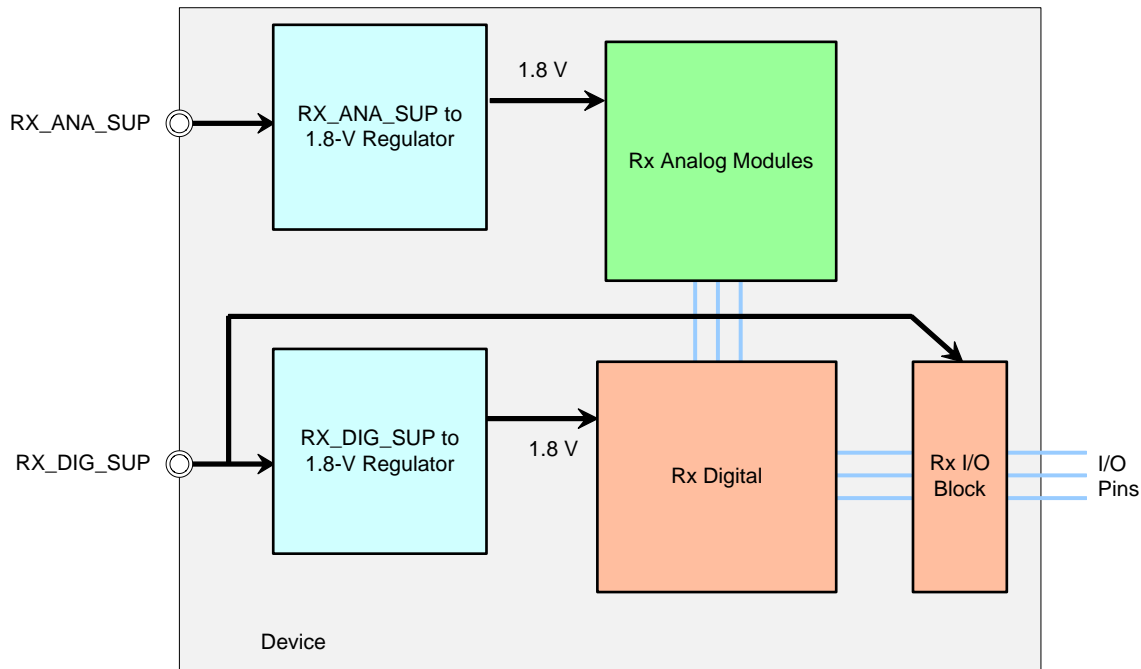

Figure 50. Receive Subsystem Power Routing

8.3.5 Transmit Section

The transmit section integrates the LED driver and the LED current control section with 8-bit resolution.

The RED and IR LED reference currents can be independently set. The current source (I_{LED}) locally regulates and ensures that the actual LED current tracks the specified reference. The transmitter section uses an internal 0.25-V reference voltage for operation. This reference voltage is available on the TX_REF pin and must be decoupled to ground with a 2.2- μ F capacitor. The TX_REF voltage is derived from the TX_CTRL_SUP. The TX_REF voltage can be programmed from 0.25 V to 1 V. A lower TX_REF voltage allows a lower voltage to be supported on LED_DRV_SUP. However, the transmitter dynamic range falls in proportion to the voltage on TX_REF. Thus, a TX_REF setting of 0.5 V gives a 6-dB lower transmitter dynamic range as compared to a 1-V setting on TX_REF, and a 6-dB higher transmitter dynamic range as compared to a 0.25-V setting on TX_REF.

Note that reducing the value of the band-gap reference capacitor on the BG pin reduces the time required for the device to wake-up and settle. However, this reduction in time is a trade-off between wake-up time and noise performance. For example, reducing the value of the capacitors on the BG and TX_REF pins from 2.2 μ F to 0.1 μ F reduces the wake-up time (from complete power-down) from 1000 ms to 100 ms, but results in a few decibels of degradation in the transmitter dynamic range.

The minimum LED_DRV_SUP voltage required for operation depends on:

- Voltage drop across the LED (V_{LED}),
- Voltage drop across the external cable, connector, and any other component in series with the LED (V_{CABLE}), and
- Transmitter reference voltage.

See the [Recommended Operating Conditions](#) table for further details.

Two LED driver schemes are supported:

- An H-bridge drive for a two-terminal back-to-back LED package; see [Figure 51](#).
- A push-pull drive for a three-terminal LED package; see [Figure 52](#).

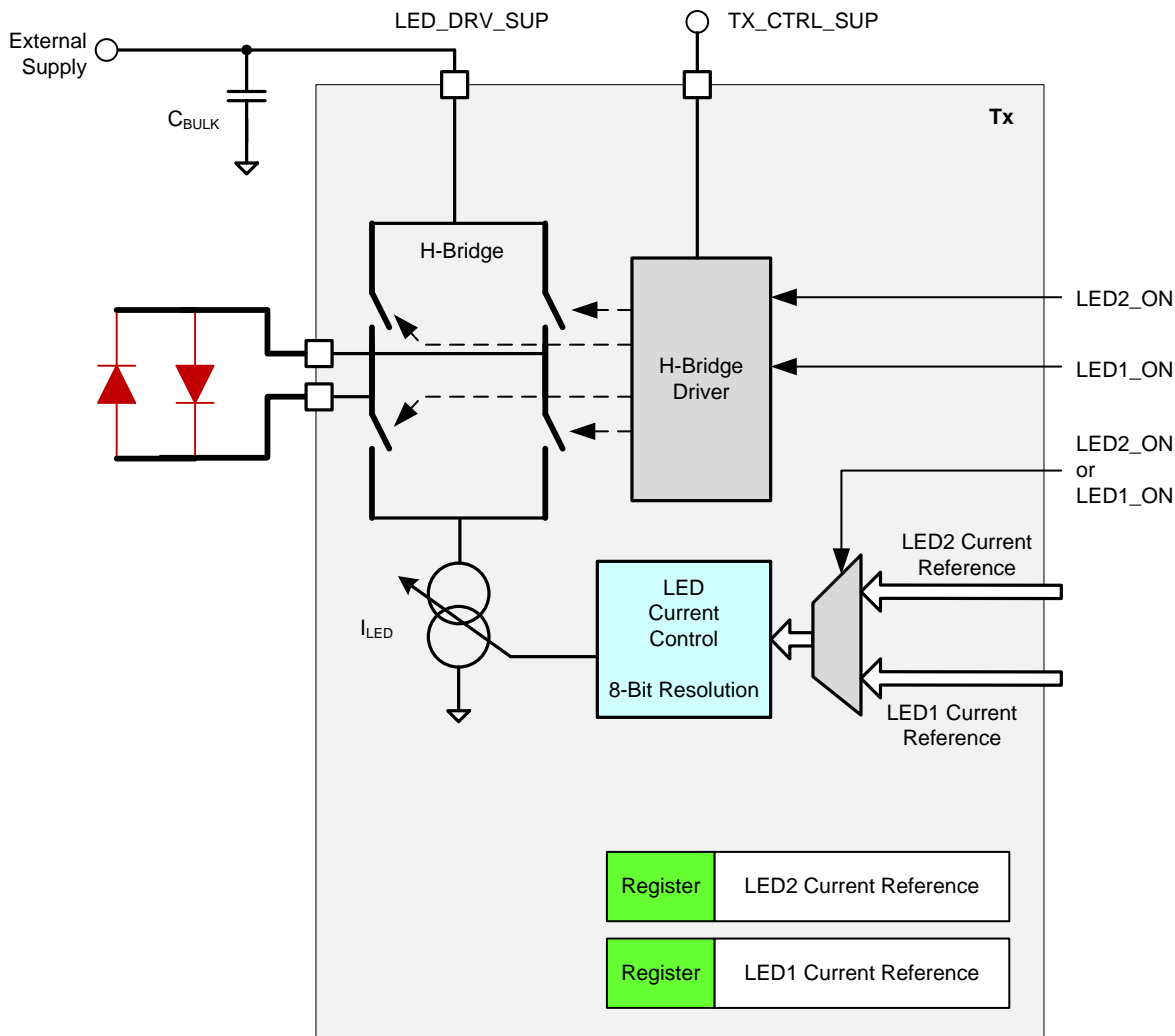

Figure 51. Transmit: H-Bridge Drive

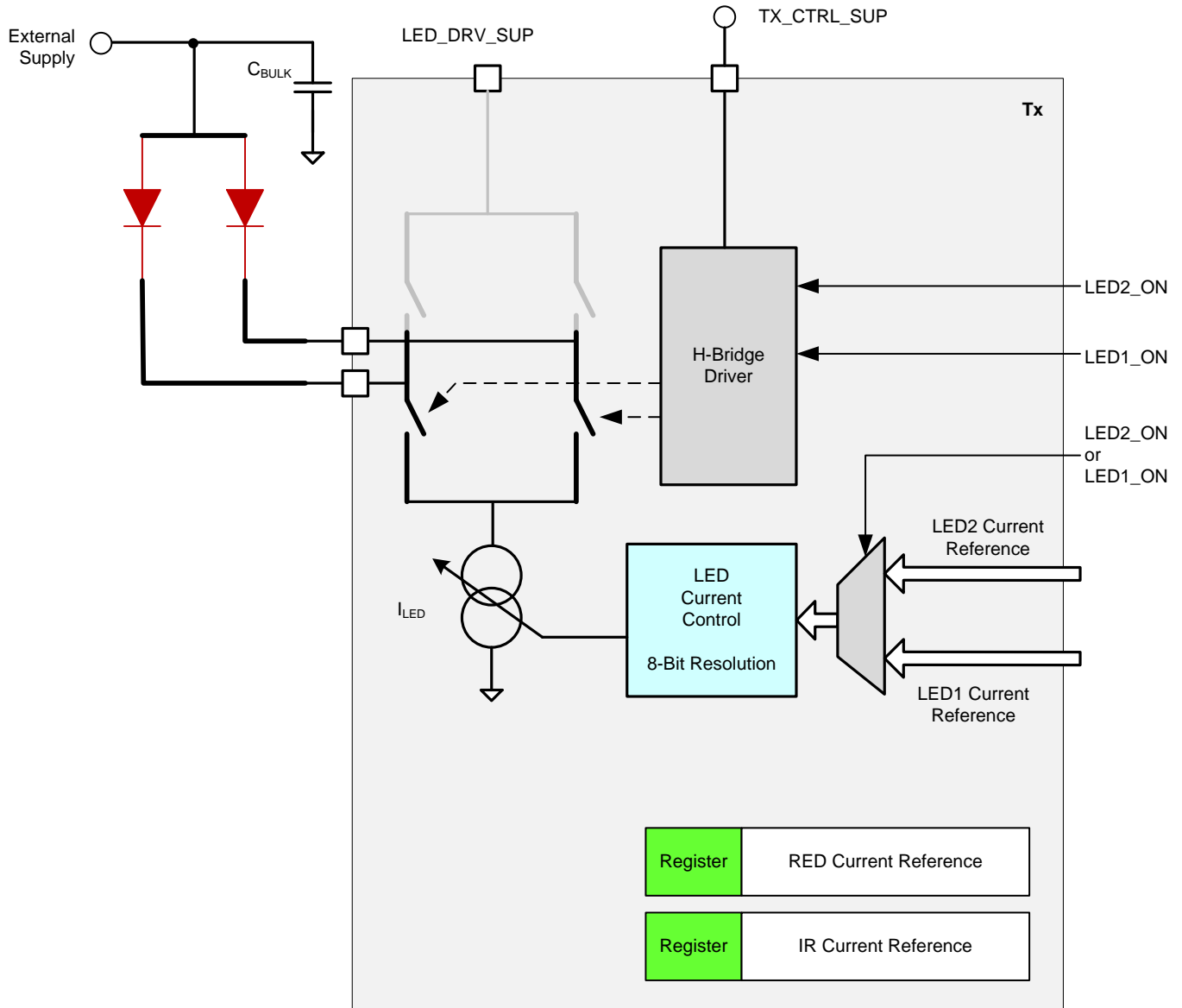

Figure 52. Transmit: Push-Pull LED Drive for Common Anode LED Configuration

8.3.5.1 Third LED Support

A third LED can be optionally connected on the TX3 pin, as shown in [Figure 53](#). An example application involving a third LED is where the Red and IR LEDs are connected on the TXP, TXN pins for pulse oximeter applications and a third LED (for example a Green LED) is connected on the TX3 pin for a heart rate monitoring application. The third LED can be connected only in common anode configuration. By programming the TX3_MODE register bit, the timing engine controls on TXP can be transferred to the TX3 pin. In this mode, the register bits that indicate the diagnostic results on the TXP pin now indicate the diagnostic results on the TX3 pin. The selection between using TX3 versus using TXP, TXN is intended as a static mode selection as opposed to a dynamic switching selection. A typical time delay of approximately 20 ms is required for the receive channel to settle after a change to the TX3_MODE setting. During this transition time, the receive signal chain should be active so that the filters are able to settle to the new signal level from the third LED.

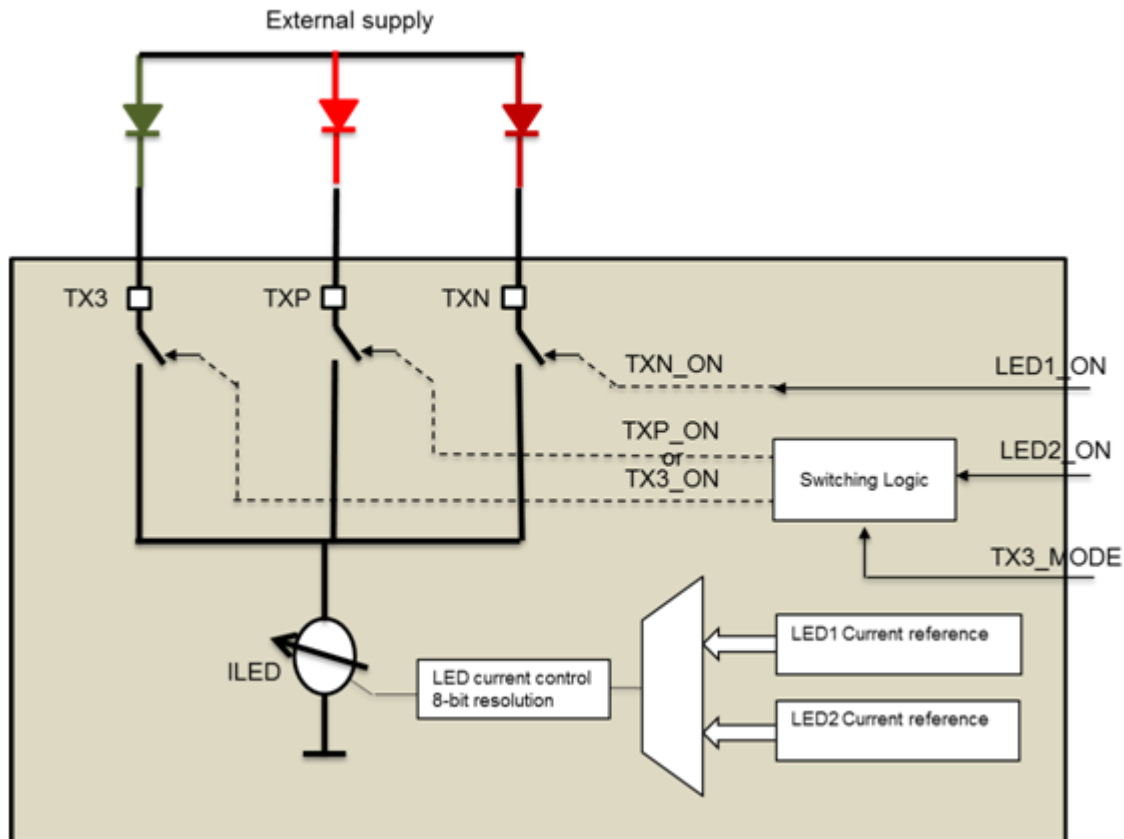

Figure 53. Multiplexing Third LED

8.3.5.2 Transmitter Power Path

The block diagram in [Figure 54](#) shows the AFE4403 Tx subsystem power routing.

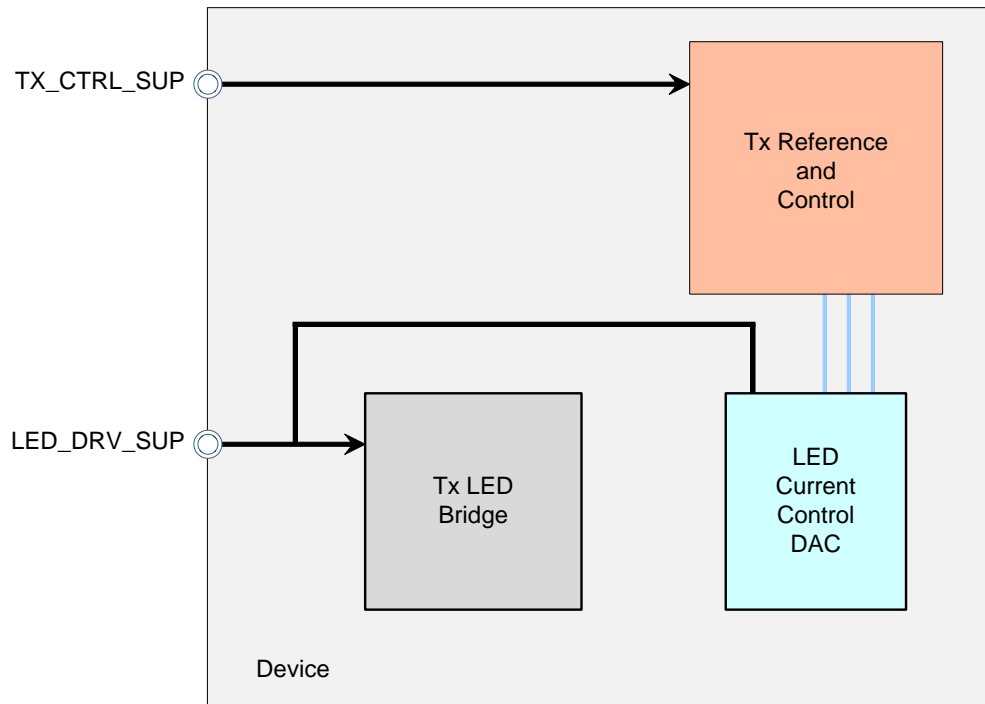

Figure 54. Transmit Subsystem Power Routing

8.3.5.3 LED Power Reduction During Periods of Inactivity

The diagram in [Figure 55](#) shows how LED bias current passes 50 μA whenever LED_ON occurs. In order to minimize power consumption in periods of inactivity, the LED_ON control must be turned off. Furthermore, the TIMEREN bit in the CONTROL1 register should be disabled by setting the value to 0.

Note that depending on the LEDs used, the LED may sometimes appear dimly lit even when the LED current is set to 0 mA. This appearance is because of the switching leakage currents (as shown in [Figure 55](#)) inherent to the timer function. The dimmed appearance does not effect the ambient light level measurement because during the ambient cycle, LED_ON is turned off for the duration of the ambient measurement.

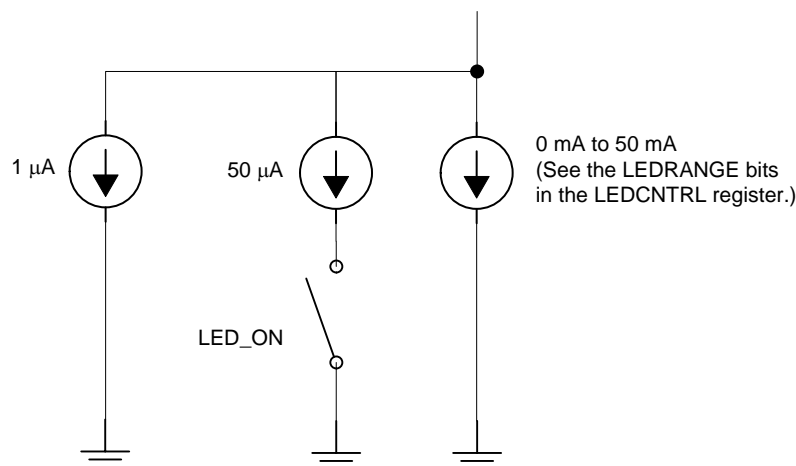

Figure 55. LED Bias Current

8.3.5.4 LED Configurations

Multiple LED configurations are possible with the AFE4403.

Case 1: Red, IR LEDs in the common anode configuration for SPO2 and a Green LED for the HRM. [Figure 56](#) shows the common anode configuration for this case. [Figure 57](#) shows the configuration for HRM mode.

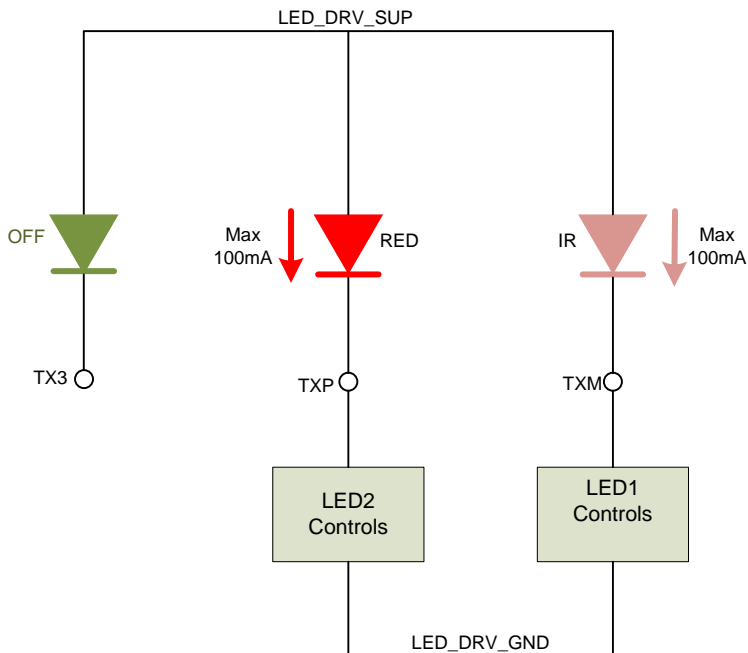

Figure 56. SPO2 Application, Common Anode Configuration

HRM mode: Set TX3_MODE = 1.

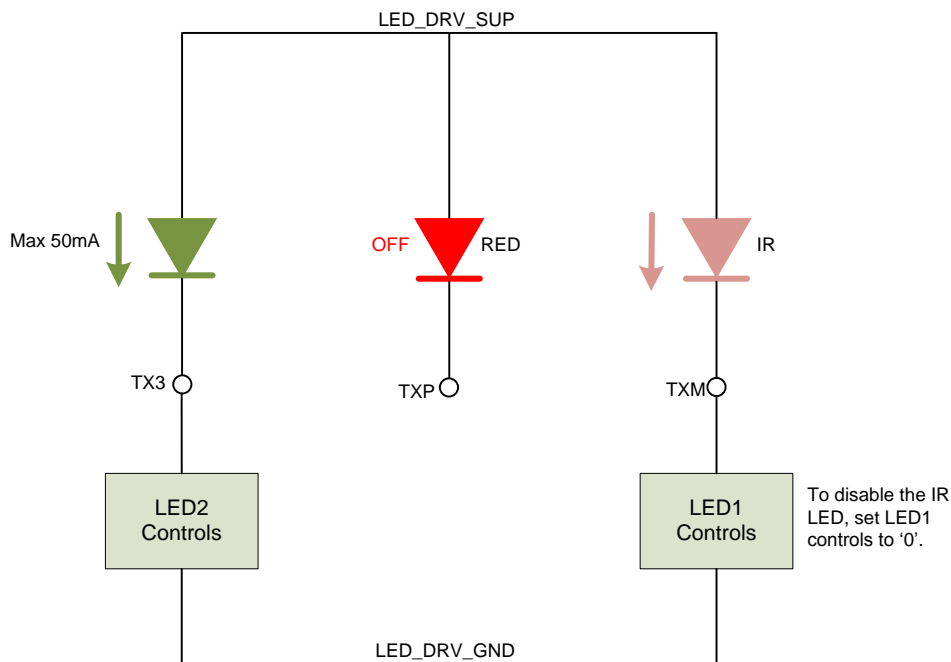

Figure 57. HRM Application Using the Third LED (Optional use of the IR LED)

Case 2: Red, IR LEDs in an H-bridge configuration for SPO2 and a Green LED for the HRM. The H-bridge configuration for this case is shown in Figure 58. Figure 59 shows the configuration for HRM mode.

SPO2 mode: Set TX3_MODE = 0.

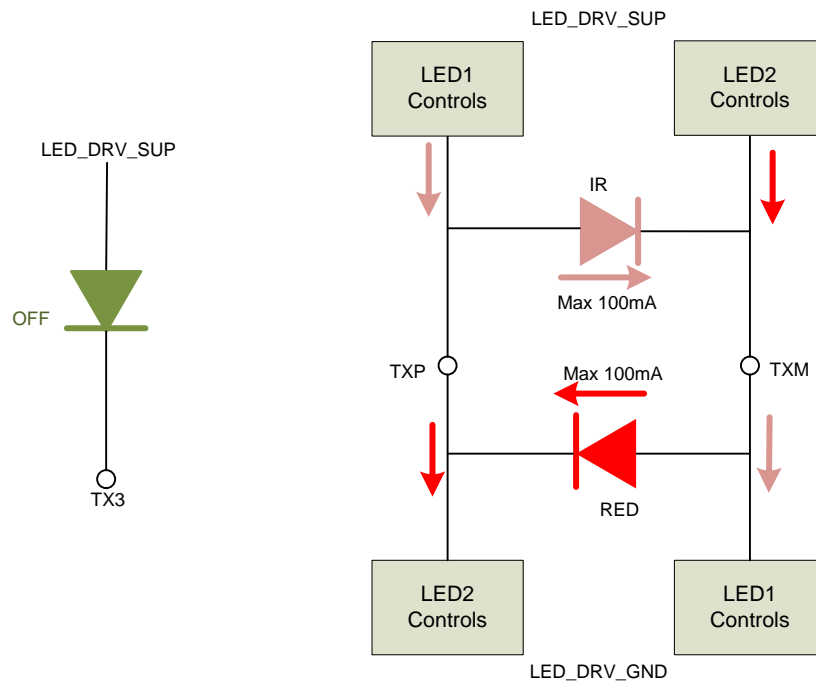

Figure 58. SPO2 Application, H-Bridge Configuration

HRM mode: Set TX3_MODE = 1.

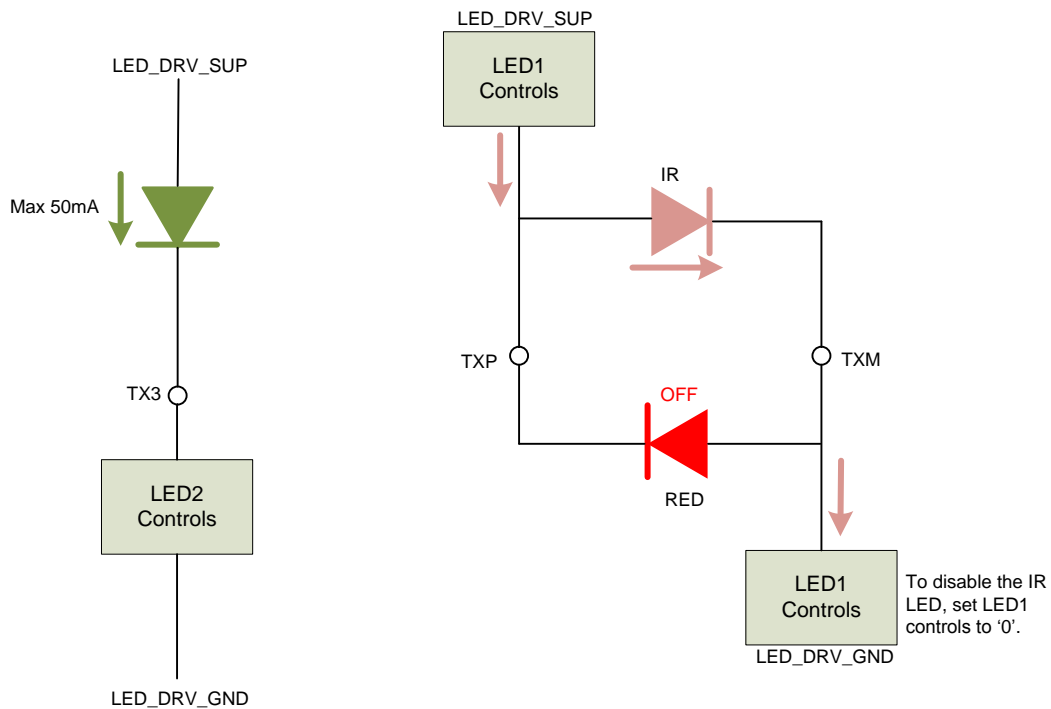

Figure 59. HRM Application Using the Third LED

Case 3: Driving two LEDs simultaneously for HRM.

Some sensor modules have two LEDs on either side of the photodiode to make the illumination more uniform. The two LEDs can be connected in parallel, as shown in [Figure 60](#).

The connection shown in [Figure 60](#) results in an equal split of the current between the two LEDs if their forward voltages are exactly matched. High mismatch in the forward voltages of the two LEDs can cause one of them to consume the majority of the current.

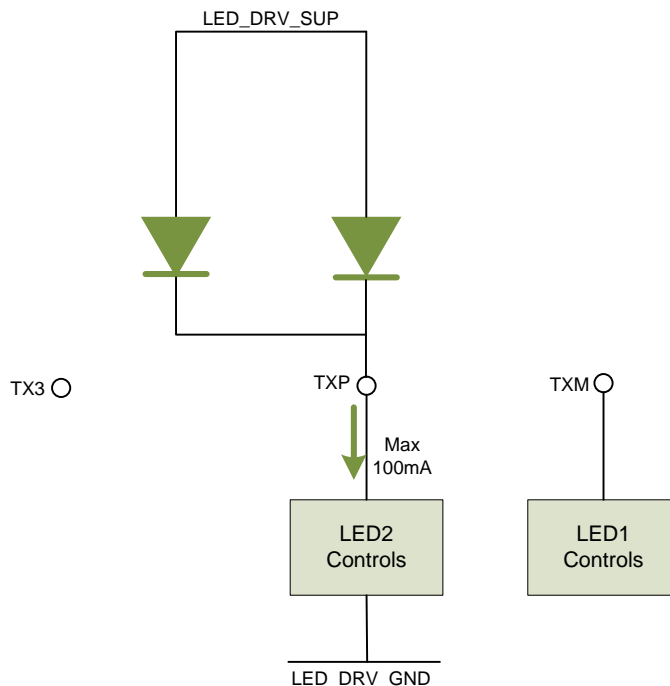

Figure 60. Using Two Parallel LEDs for an HRM Application

Case 4: Driving two LEDs separated in time for HRM.

The two LEDs can also be driven as shown in [Figure 61](#).

While this mode of driving the two LEDs does not drive them simultaneously, there are two advantages in this case. First, the full current is available for driving each LED. Secondly, the mismatch in the forward voltages between the two LEDs does not play a role.

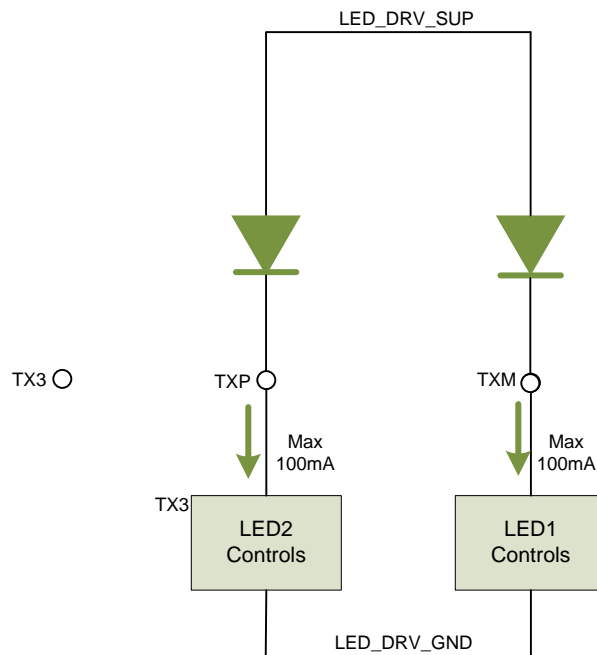

Figure 61. Using Two Parallel LEDs for an HRM Application with Separation in Timing

8.4 Device Functional Modes

8.4.1 ADC Operation and Averaging Module

After the falling edge of the ADC reset signal, the ADC conversion phase starts (refer to Figure 49). Each ADC conversion takes 50 μ s.

The ADC operates with averaging. The averaging module averages multiple ADC samples and reduces noise to improve dynamic range. Figure 62 shows a diagram of the averaging module. The ADC output is a 22-bit code that is obtained by discarding the two MSBs of the 24-bit registers (for example the register with address 2Ah), as shown in Figure 63.

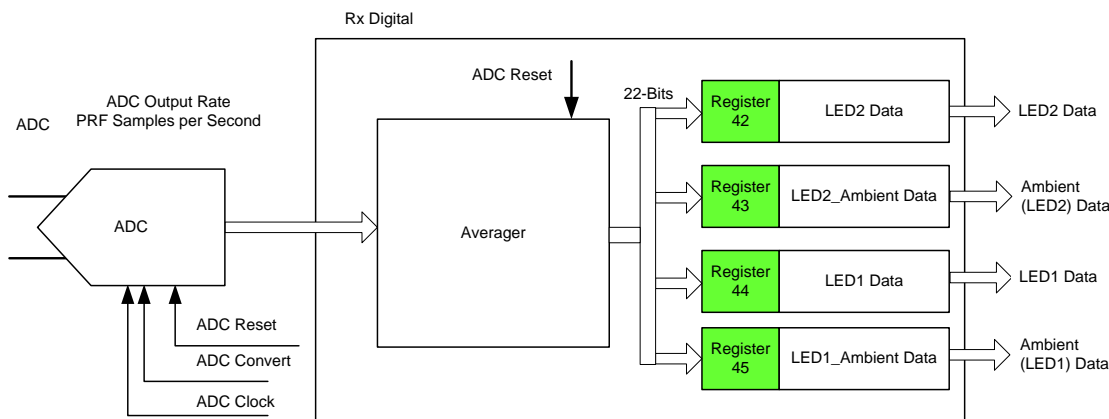

Figure 62. Averaging Module

Figure 63. 22-Bit Word

23	22	21	20	19	18	17	16	15	14	13	12
Ignore											22-Bit ADC Code, MSB to LSB
11	10	9	8	7	6	5	4	3	2	1	0
22-Bit ADC Code, MSB to LSB											

Table 3 shows the mapping of the input voltage to the ADC to its output code.

Table 3. ADC Input Voltage Mapping

DIFFERENTIAL INPUT VOLTAGE AT ADC INPUT	22-BIT ADC OUTPUT CODE
-1.2 V	10000000000000000000
$(-1.2 / 2^{21})$ V	11111111111111111111
0	00000000000000000000
$(1.2 / 2^{21})$ V	00000000000000000001
1.2 V	01111111111111111111

The data format is binary twos complement format, MSB-first. Because the TIA has a full-scale range of ± 1 V, TI recommends that the input to the ADC does not exceed ± 1 V, which is approximately 80% of its full-scale.

In cases where having the processor read the data as a 24-bit word instead of a 22-bit word is more convenient, the entire register can be mapped to the input level as shown in Figure 64.

Figure 64. 24-Bit Word

23	22	21	20	19	18	17	16	15	14	13	12	11	10	9	8	7	6	5	4	3	2	1	0
24-Bit ADC Code, MSB to LSB																							

Table 4 shows the mapping of the input voltage to the ADC to its output code when the entire 24-bit word is considered.

Table 4. Input Voltage Mapping

DIFFERENTIAL INPUT VOLTAGE AT ADC INPUT	24-BIT ADC OUTPUT CODE
-1.2 V	111000000000000000000000
$(-1.2 / 2^{21})$ V	111111111111111111111111
0	000000000000000000000000
$(1.2 / 2^{21})$ V	000000000000000000000001
1.2 V	000111111111111111111111

Now the data can be considered as a 24-bit data in binary twos complement format, MSB-first. The advantage of using the entire 24-bit word is that the ADC output is correct, even when the input is over the normal operating range.

8.4.1.1 Operation Without Averaging

In this mode, the ADC outputs a digital sample one time for every 50 μ s. Consider a case where the ADC_RDY signals are positioned at 25%, 50%, 75%, and 100% points in the pulse repetition period. At the next rising edge of the ADC reset signal, the first 22-bit conversion value is written into the result registers sequentially as follows (see Figure 65):

- At the 25% reset signal, the first 22-bit ADC sample is written to register 2Ah.
- At the 50% reset signal, the first 22-bit ADC sample is written to register 2Bh.
- At the 75% reset signal, the first 22-bit ADC sample is written to register 2Ch.
- At the next 0% reset signal, the first 22-bit ADC sample is written to register 2Dh. The contents of registers 2Ah and 2Bh are written to register 2Eh and the contents of registers 2Ch and 2Dh are written to register 2Fh.

At the rising edge of the ADC_RDY signal, the contents of all six result registers can be read out.

8.4.1.2 Operation With Averaging

In this mode, all ADC digital samples are accumulated and averaged after every 50 μ s. At the next rising edge of the ADC reset signal, the average value (22-bit) is written into the output registers sequentially, as follows (see Figure 66):

- At the 25% reset signal, the averaged 22-bit word is written to register 2Ah.
- At the 50% reset signal, the averaged 22-bit word is written to register 2Bh.
- At the 75% reset signal, the averaged 22-bit word is written to register 2Ch.
- At the next 0% reset signal, the averaged 22-bit word is written to register 2Dh. The contents of registers 2Ah and 2Bh are written to register 2Eh and the contents of registers 2Ch and 2Dh are written to register 2Fh.

At the rising edge of the ADC_RDY signal, the contents of all six result registers can be read out.

The number of samples to be used per conversion phase is specified in the CONTROL1 register (NUMAV[7:0]). The user must specify the correct value for the number of averages, as described in Equation 6:

$$\text{NUMAV}[7:0] + 1 = \left\lceil \frac{0.25 \times \text{Pulse Repetition Period}}{50 \mu\text{s}} \right\rceil - 1 \quad (6)$$

Note that the 50- μ s factor corresponds to a case where the internal clock of the AFE (after division) is exactly equal to 4 MHz. The factor scales linearly with the clock period being used.

When the number of averages is 0, the averaging is disabled and only one ADC sample is written to the result registers.

Note that the number of average conversions is limited by 25% of the PRF. For example, eight samples can be averaged with PRF = 625 Hz, and four samples can be averaged with PRF = 1250 Hz.

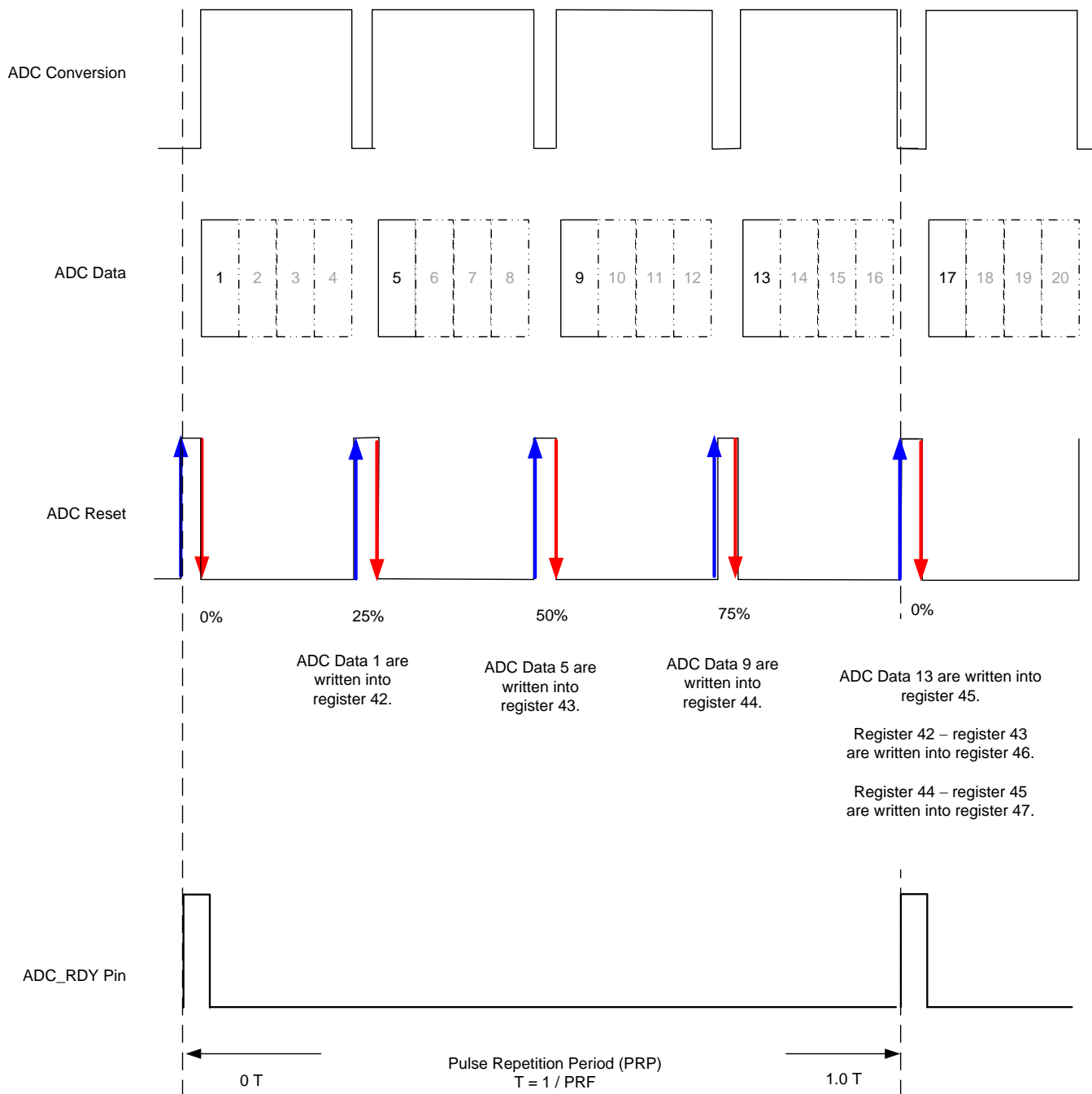
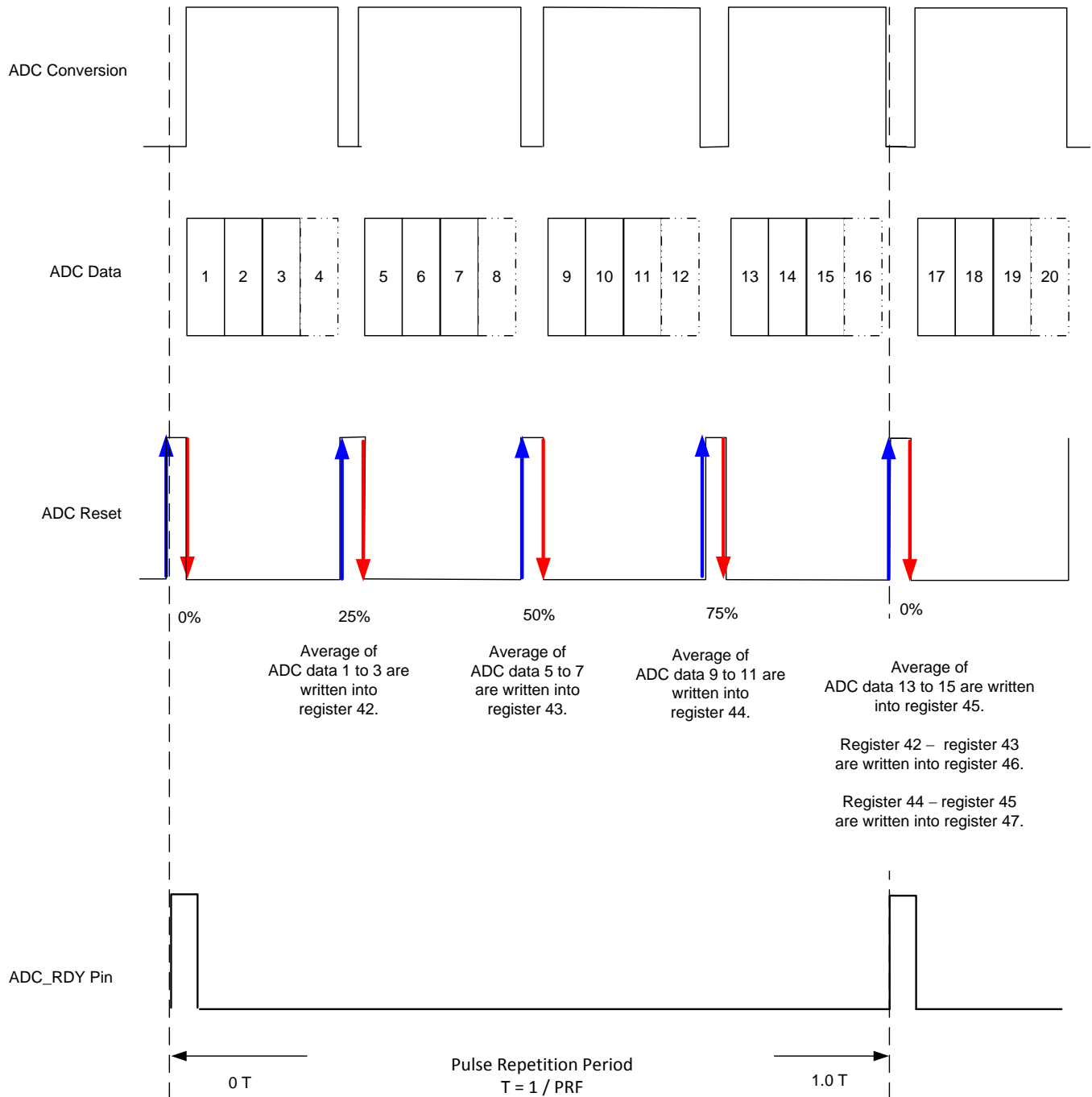

Figure 65. ADC Data Without Averaging (When Number of Averages = 0)



NOTE: Example is with three averages. The value of the NUMAVG[7:0] register bits = 2.

Figure 66. ADC Data with Averaging Enabled

8.4.1.3 Dynamic Power-Down Mode

When operated at low PRF, a dynamic power-down mode can be optionally enabled to shut off blocks during a portion of each period. This operation is illustrated in Figure 67. The dynamic power-down signal (called PDN_CYCLE) can be internally generated using the timing controller. PDN_CYCLE can be used to shut off power to internal blocks during the unused section within each pulse repetition period.

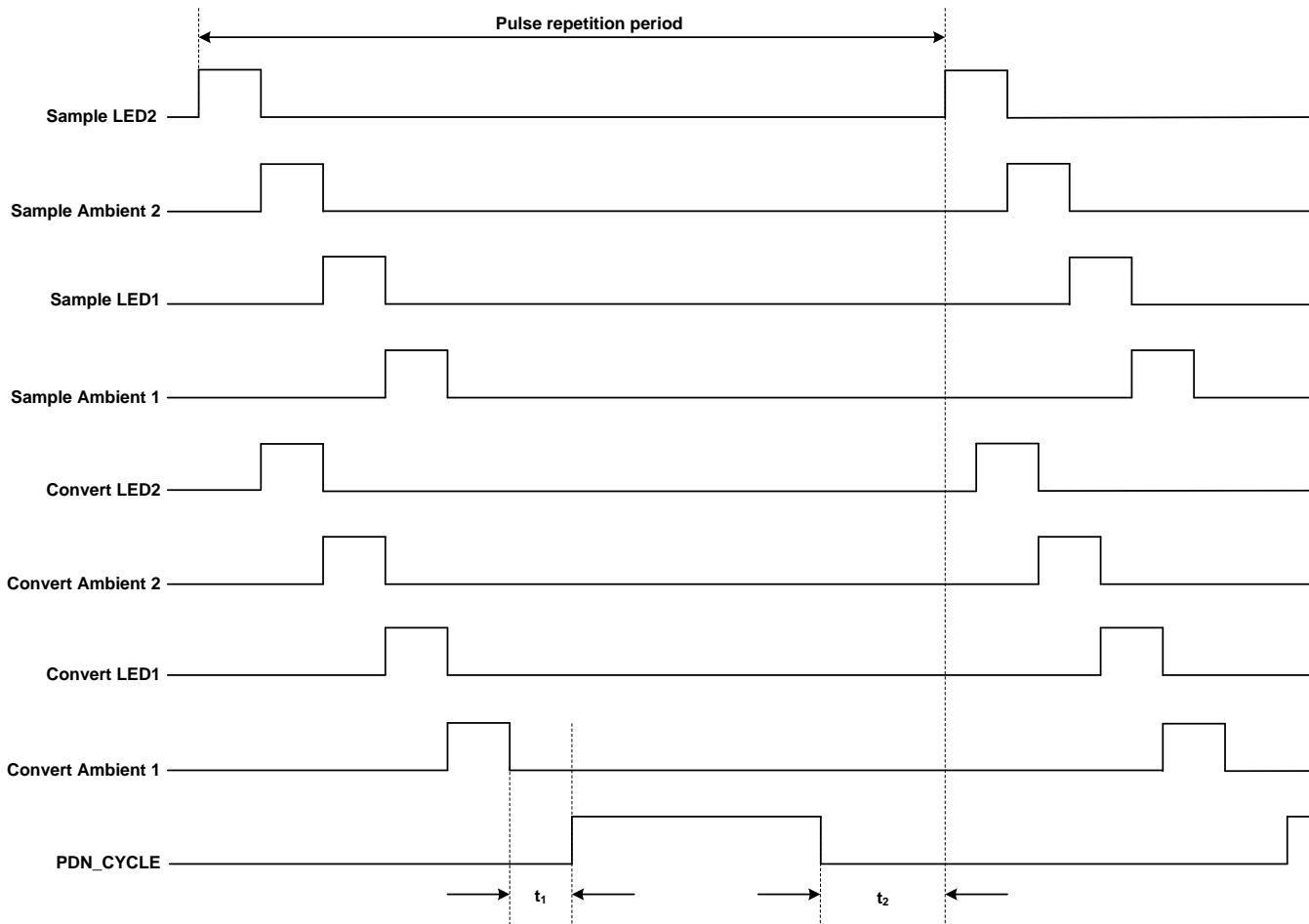

Figure 67. Dynamic Power-Down Mode Timing

t_1 and t_2 denote the timing margin between the active portion of the period and the dynamic power-down signal. TI recommends setting $t_1 > 50 \mu\text{s}$ and $t_2 > 200 \mu\text{s}$ in order to ensure sufficient time for the shutdown blocks to recover from power-down. By choosing the blocks that are shut down during dynamic power-down, a power savings of anywhere between 35% to 70% power can be achieved when the PDN_CYCLE phase is active.

The sequence of the convert phases within a pulse repetition period should be as follows: LED2 (Red) → Ambient 2 → LED1 (IR) → Ambient 1. The sample phases must precede the corresponding convert phase. Also note that the ADC_RDY signal comes at the beginning of the pulse repetition period. Thus, the contents of the registers must be read before the completion of the first conversion phase in the pulse repetition period. These contents correspond to the samples of the four phases from the previous pulse repetition period.

The DYNAMIC1, DYNAMIC2, DYNAMIC3, and DYNAMIC4 bits determine which blocks are powered down during the dynamic power-down state (when PDN_CYCLE is high). For maximum power saving, all four bits can be set to 1. TI recommends setting t_1 to greater than $100 \mu\text{s}$ and t_2 to greater than $200 \mu\text{s}$ to ensure that the blocks recover from power-down in time for the next cycle.

The bit corresponding to the TIA power-down (DYNAMIC3) needs a bit more consideration. When the TIA is powered down, the TIA no longer maintains the bias across the photodiode output. This loss of bias can cause the photodiode output voltage to drift from the normal value. The recovery time constant associated with the photodiode returning to a proper bias condition (when the TIA is powered back on) is approximately equal to $2 \times C_{PD} \times R_F$, where C_{PD} is the effective differential capacitance of the photodiode and R_F is the TIA gain setting. This consideration might result in a different choice for the value of t_2 .

8.4.2 Diagnostics

The device includes diagnostics to detect open or short conditions of the LED and photosensor, LED current profile feedback, and cable on or off detection.

8.4.2.1 Photodiode-Side Fault Detection

Figure 68 shows the diagnostic for the photodiode-side fault detection.

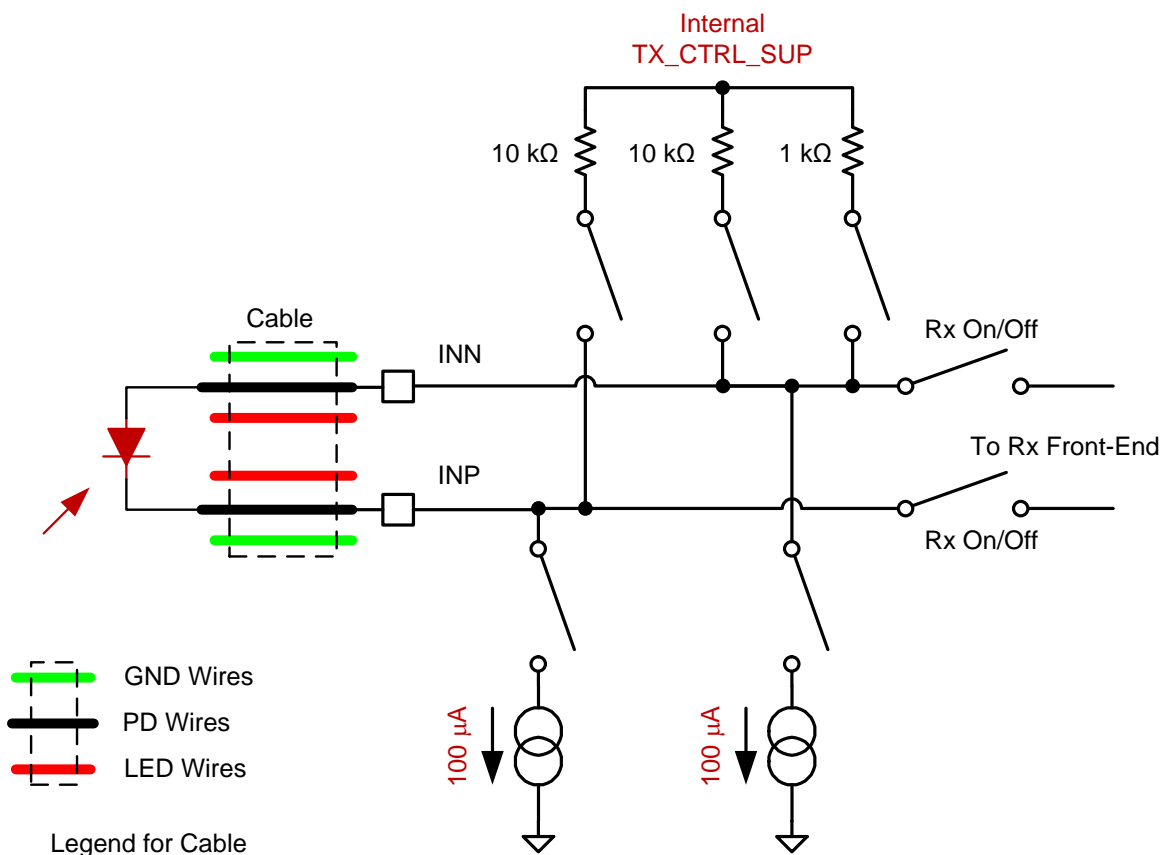

Figure 68. Photodiode Diagnostic

8.4.2.3 Diagnostics Module

The diagnostics module, when enabled, checks for nine types of faults sequentially. The results of all faults are latched in 11 separate flags.

The status of all flags can also be read using the SPI interface. [Table 5](#) details each fault and flag used. Note that the diagnostics module requires all AFE blocks to be enabled in order to function reliably.

Table 5. Fault and Flag Diagnostics⁽¹⁾

MODULE	SEQ.	FAULT	FLAG1	FLAG2	FLAG3	FLAG4	FLAG5	FLAG6	FLAG7	FLAG8	FLAG9	FLAG10	FLAG11
—	—	No fault	0	0	0	0	0	0	0	0	0	0	0
PD	1	Rx INP cable shorted to LED cable	1										
	2	Rx INN cable shorted to LED cable		1									
	3	Rx INP cable shorted to GND cable			1								
	4	Rx INN cable shorted to GND cable				1							
	5	PD open or shorted					1	1					
LED	6	Tx OUTM line shorted to GND cable							1				
	7	Tx OUTP line shorted to GND cable								1			
	8	LED open or shorted									1	1	
	9	LED open or shorted											1

(1) Resistances below 10 kΩ are considered to be shorted.

Figure 70 shows the timing for the diagnostic function.

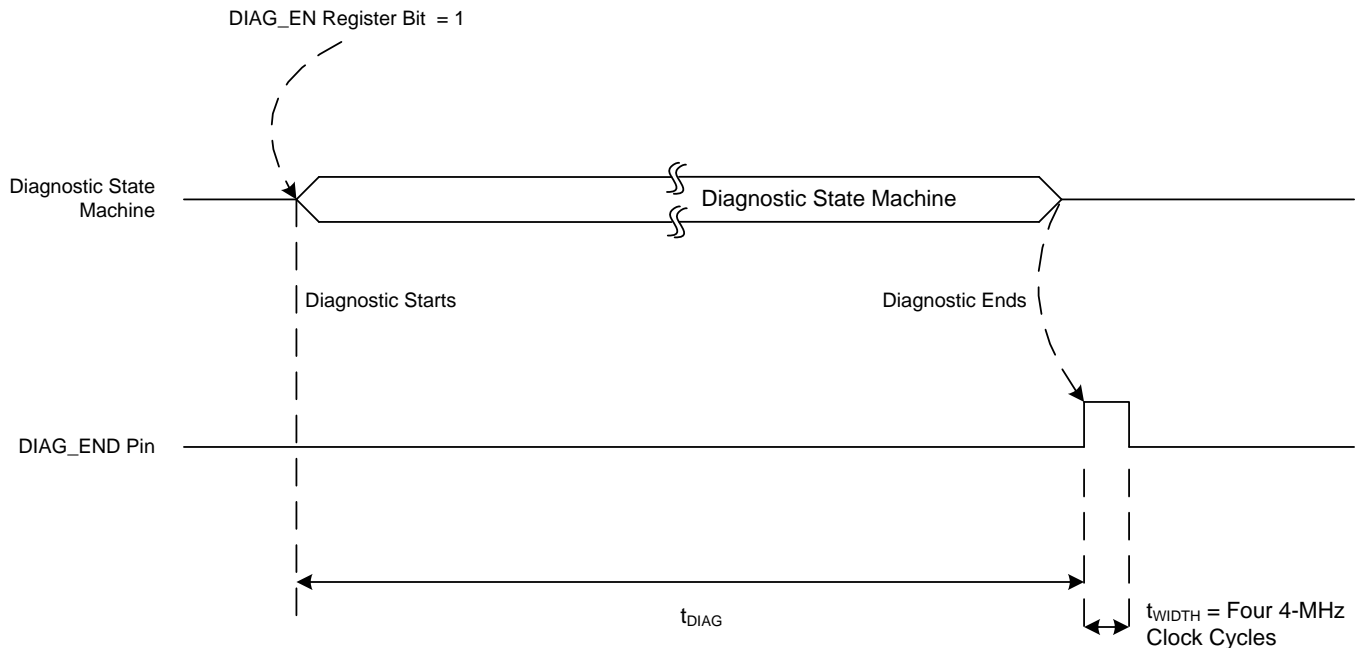

Figure 70. Diagnostic Timing Diagram

By default, the diagnostic function takes $t_{DIAG} = 16$ ms to complete. After the diagnostics function completes, the AFE4403 filter must be allowed time to settle. See the [Electrical Characteristics](#) for the filter settling time.

8.5 Programming

8.5.1 Serial Programming Interface

The SPI-compatible serial interface consists of four signals: SCLK (serial clock), SPISOMI (serial interface data output), SPISIMO (serial interface data input), and SPISTE (serial interface enable).

The serial clock (SCLK) is the serial peripheral interface (SPI) serial clock. SCLK shifts in commands and shifts out data from the device. SCLK features a Schmitt-triggered input and clocks data out on the SPISOMI. Data are clocked in on the SPISIMO pin. Even though the input has hysteresis, TI recommends keeping SCLK as clean as possible to prevent glitches from accidentally shifting the data. When the serial interface is idle, hold SCLK low.

The SPI serial out master in (SPISOMI) pin is used with SCLK to clock out the AFE4403 data. The SPI serial in master out (SPISIMO) pin is used with SCLK to clock in data to the AFE4403. The SPI serial interface enable (SPISTE) pin enables the serial interface to clock data on the SPISIMO pin in to the device.

8.5.2 Reading and Writing Data

The device has a set of internal registers that can be accessed by the serial programming interface formed by the SPISTE, SCLK, SPISIMO, and SPISOMI pins.

8.5.2.1 Writing Data

The SPI_READ register bit must be first set to 0 before writing to a register. When SPISTE is low:

- Serially shifting bits into the device is enabled.
- Serial data (on the SPISIMO pin) are latched at every SCLK rising edge.
- The serial data are loaded into the register at every 32nd SCLK rising edge.

Programming (continued)

In case the word length exceeds a multiple of 32 bits, the excess bits are ignored. Data can be loaded in multiples of 32-bit words within a single active SPISTE pulse. The first eight bits form the register address and the remaining 24 bits form the register data. [Figure 71](#) shows an SPI timing diagram for a single write operation. For multiple read and write cycles, refer to the [Multiple Data Reads and Writes](#) section.

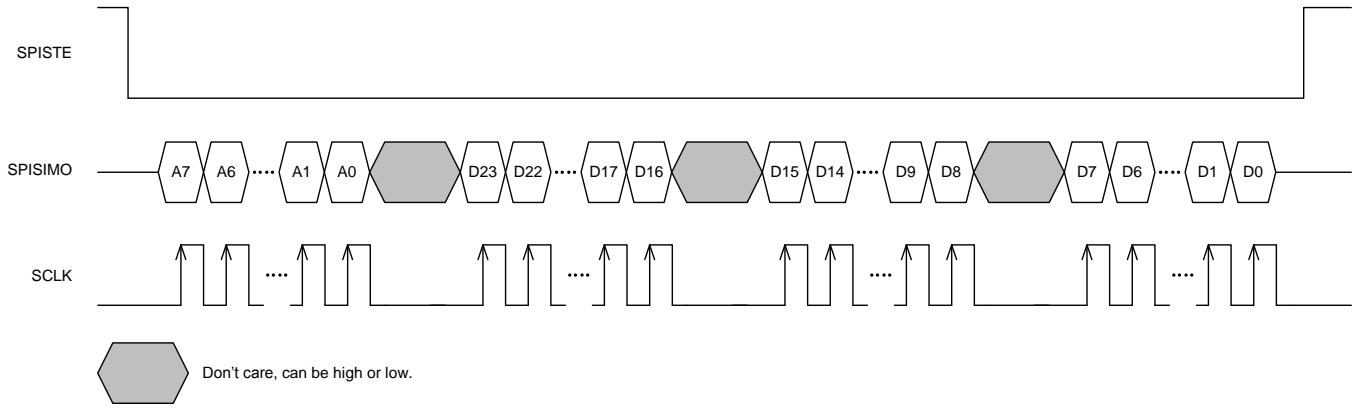
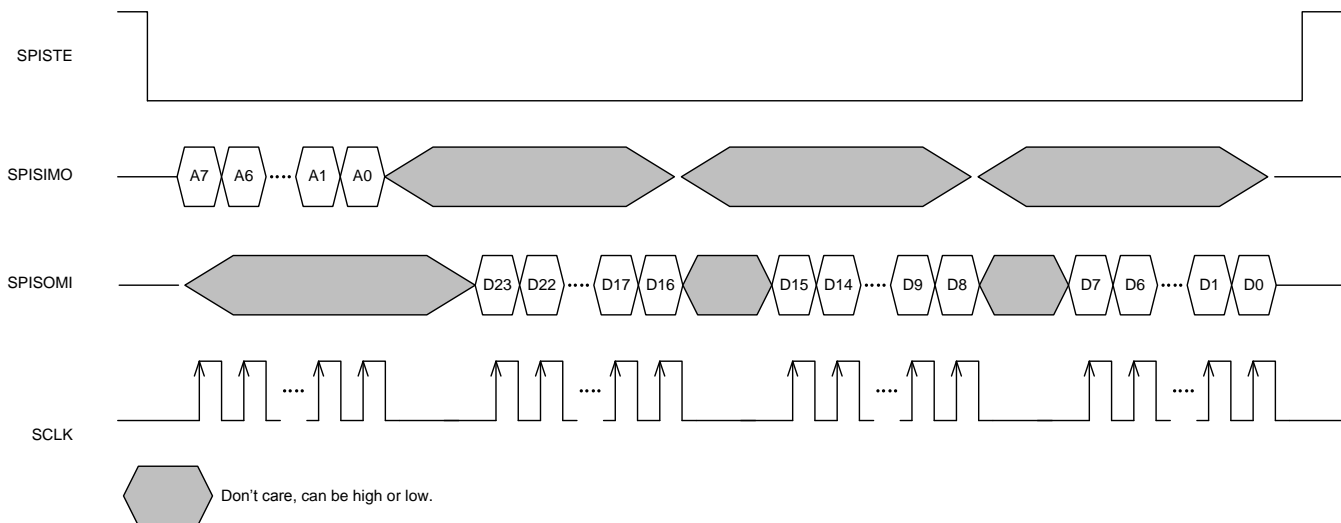

Figure 71. AFE SPI Write Timing Diagram

Programming (continued)

8.5.2.2 Reading Data

The SPI_READ register bit must be first set to 1 before reading from a register. The AFE4403 includes a mode where the contents of the internal registers can be read back on the SPISOMI pin. This mode may be useful as a diagnostic check to verify the serial interface communication between the external controller and the AFE. To enable this mode, first set the SPI_READ register bit using the SPI write command, as described in the [Writing Data](#) section. In the next command, specify the SPI register address with the desired content to be read. Within the same SPI command sequence, the AFE outputs the contents of the specified register on the SPISOMI pin. [Figure 72](#) shows an SPI timing diagram for a single read operation. For multiple read and write cycles, refer to the [Multiple Data Reads and Writes](#) section.



- (1) The SPI_READ register bit must be enabled before attempting a serial readout from the AFE.
- (2) Specify the register address of the content that must be readback on bits A[7:0].
- (3) The AFE outputs the contents of the specified register on the SPISOMI pin.

Figure 72. AFE SPI Read Timing Diagram

8.5.2.3 Multiple Data Reads and Writes

The device includes functionality where multiple read and write operations can be performed during a single SPISTE event. To enable this functionality, the first eight bits determine the register address to be written and the remaining 24 bits determine the register data. Perform two writes with the SPI read bit enabled during the second write operation in order to prepare for the read operation, as described in the [Writing Data](#) section. In the next command, specify the SPI register address with the desired content to be read. Within the same SPI command sequence, the AFE outputs the contents of the specified register on the SPISOMI pin. This functionality is described in the [Writing Data](#) and [Reading Data](#) sections. [Figure 73](#) shows a timing diagram for the SPI multiple read and write operations.

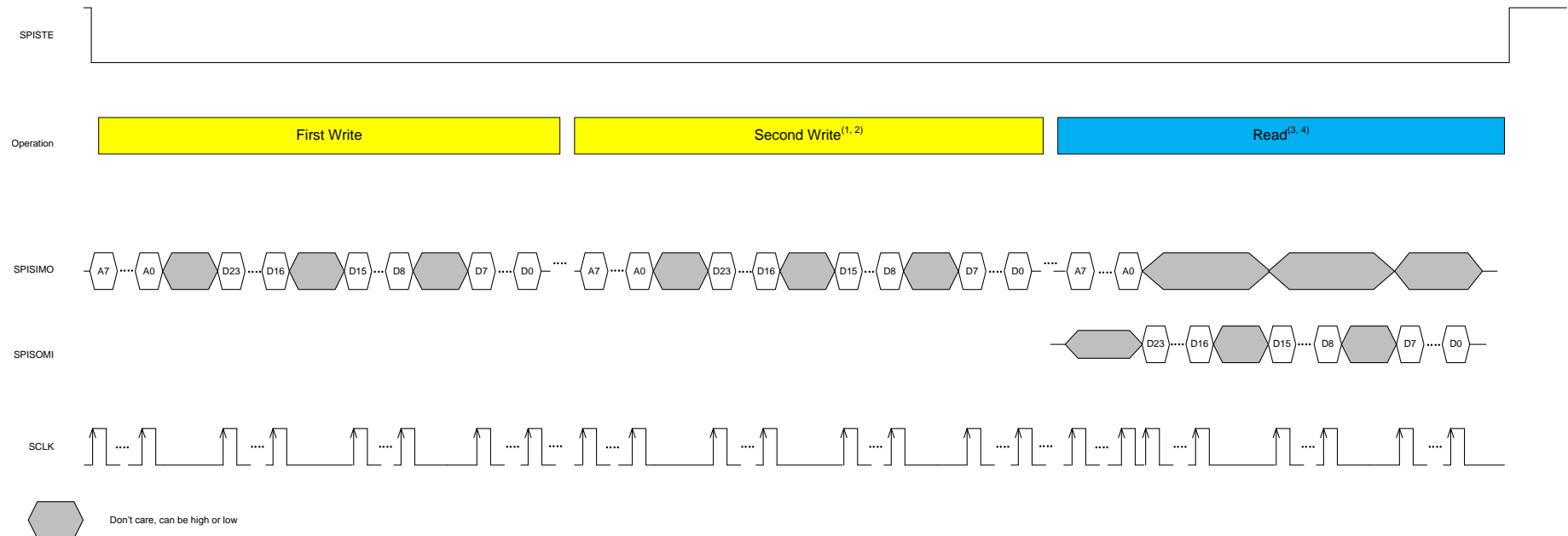

- (1) The SPI read register bit must be enabled before attempting a serial readout from the AFE.
- (2) The second write operation must be configured for register 0 with data 000001h.
- (3) Specify the register address whose contents must be read back on A[7:0].
- (4) The AFE outputs the contents of the specified register on the SPISOMI pin.

Figure 73. Serial Multiple Read and Write Operations

8.5.2.4 Register Initialization

After power-up, the internal registers **must** be initialized to the default values. This initialization can be done in one of two ways:

- Through a hardware reset by applying a low-going pulse on the $\overline{\text{RESET}}$ pin, or
- By applying a software reset. Using the serial interface, set SW_RESET (bit D3 in register 00h) high. This setting initializes the internal registers to the default values and then self-resets to 0. In this case, the $\overline{\text{RESET}}$ pin is kept high (inactive).

8.5.2.5 AFE SPI Interface Design Considerations

Note that when the AFE4403 is deselected, the SPISOMI, CLKOUT, ADC_RDY, and DIAG_END digital output pins do not enter a 3-state mode. This condition, therefore, must be taken into account when connecting multiple devices to the SPI port and for power-management considerations. In order to avoid loading the SPI bus when multiple devices are connected, the SOMI_TRI register bit must be to 1 whenever the AFE SPI is inactive. The DIGOUT_TRISTATE register bit must be set to 1 to tri-state the ADC_RDY and DIAG_END pins. The CLKOUT_TRI register bit must be set to 1 to put the CLKOUT buffer in tri-state mode.

Table 6. AFE Register Map (continued)

NAME	REGISTER CONTROL ⁽¹⁾	ADDRESS		REGISTER DATA																								
		Hex	Dec	23	22	21	20	19	18	17	16	15	14	13	12	11	10	9	8	7	6	5	4	3	2	1	0	
ADCRSTSTCT3	R/W	1B	27	0	0	0	0	0	0	0	0	ADCRSTCT3[15:0]																
ADCRSTENDCT3	R/W	1C	28	0	0	0	0	0	0	0	0	ADCRENDCT3[15:0]																
PRPCOUNT	R/W	1D	29	0	0	0	0	0	0	0	0	PRPCT[15:0]																
CONTROL1	R/W	1E	30	0	0	0	0	0	0	0	0	0	0	0	0	0	0	0	TIMEREN	NUMAV[7:0]								
SPARE1	N/A	1F	31	0	0	0	0	0	0	0	0	0	0	0	0	0	0	0	0	0	0	0	0	0	0	0	0	0
TIAGAIN	R/W	20	32	0	0	0	0	0	0	0	0	ENSEPGAN	STAGE2EN1	0	0	0	STG2GAIN1[2:0]			CF_LED1[4:0]				RF_LED1[2:0]				
TIA_AMB_GAIN	R/W	21	33	0	0	0	0	AMBDAC[3:0]			FLTRNRSEL	STAGE2EN	0	0	0	STG2GAIN2[2:0]			CF_LED[4:0]				RF_LED[2:0]					
LEDCNTRL	R/W	22	34	0	0	0	0	0	0	LED_RANGE[1:0]		LED1[7:0]								LED2[7:0]								
CONTROL2	R/W	23	35	0	0	0	DYNAMIC1	0	TX_REF1	TX_REF0	0	0	DYNAMIC2	0	0	TXBRGMOD	DIGOUT_TRISTATE	XTALDIS	EN_SLOW_DIAG	0	0	0	DYNAMIC3	DYNAMIC4	PDNTX	PDNRX	PDNAFE	
SPARE2	N/A	24	36	0	0	0	0	0	0	0	0	0	0	0	0	0	0	0	0	0	0	0	0	0	0	0	0	0
SPARE3	N/A	25	37	0	0	0	0	0	0	0	0	0	0	0	0	0	0	0	0	0	0	0	0	0	0	0	0	0
SPARE4	N/A	26	38	0	0	0	0	0	0	0	0	0	0	0	0	0	0	0	0	0	0	0	0	0	0	0	0	0
RESERVED1	N/A	27	39	X	X	X	X	X	X	X	X	X	X	X	X	X	X	X	X	X	X	X	X	X	X	X	X	X
RESERVED2	N/A	28	40	X	X	X	X	X	X	X	X	X	X	X	X	X	X	X	X	X	X	X	X	X	X	X	X	X
ALARM	R/W	29	41	0	0	0	0	0	0	0	0	0	0	0	0	0	0	0	0	0	0	0	0	0	0	0	0	0
LED2VAL	R	2A	42	LED2VAL[23:0]																								
ALED2VAL	R	2B	43	ALED2VAL[23:0]																								
LED1VAL	R	2C	44	LED1VAL[23:0]																								
ALED1VAL	R	2D	45	ALED1VAL[23:0]																								
LED2-ALED2VAL	R	2E	46	LED2-ALED2VAL[23:0]																								
LED1-ALED1VAL	R	2F	47	LED1-ALED1VAL[23:0]																								

8.6.2 AFE Register Description

Figure 74. CONTROL0: Control Register 0 (Address = 00h, Reset Value = 0000h)

23	22	21	20	19	18	17	16	15	14	13	12
0	0	0	0	0	0	0	0	0	0	0	0
11	10	9	8	7	6	5	4	3	2	1	0
0	0	0	0	0	0	0	0	SW_RST	DIAG_EN	TIM_COUNT_RST	SPI_READ

This register is write-only. CONTROL0 is used for AFE software and count timer reset, diagnostics enable, and SPI read functions.

Bits 23:4 **Must be 0**

Bit 3 **SW_RST: Software reset**

0 = No action (default after reset)

1 = Software reset applied; resets all internal registers to the default values and self-clears to 0

Bit 2 **DIAG_EN: Diagnostic enable**

0 = No action (default after reset)

1 = Diagnostic mode is enabled and the diagnostics sequence starts when this bit is set.

At the end of the sequence, all fault status are stored in the [DIAG: Diagnostics Flag Register](#). Afterwards, the DIAG_EN register bit self-clears to 0.

Note that the diagnostics enable bit is automatically reset after the diagnostics completes (16 ms). During the diagnostics mode, ADC data are invalid because of the toggling diagnostics switches.

Bit 1 **TIM_CNT_RST: Timer counter reset**

0 = Disables timer counter reset, required for normal timer operation (default after reset)

1 = Timer counters are in reset state

Bit 0 **SPI_READ: SPI read**

0 = SPI read is disabled (default after reset)

1 = SPI read is enabled

Figure 75. LED2STC: Sample LED2 Start Count Register (Address = 01h, Reset Value = 0000h)

23	22	21	20	19	18	17	16	15	14	13	12
0	0	0	0	0	0	0	0	LED2STC[15:0]			
11	10	9	8	7	6	5	4	3	2	1	0
LED2STC[15:0]											

This register sets the start timing value for the LED2 signal sample.

Bits 23:16 **Must be 0**

Bits 15:0 **LED2STC[15:0]: Sample LED2 start count**

The contents of this register can be used to position the start of the sample LED2 signal with respect to the pulse repetition period (PRP), as specified in the PRPCOUNT register. The count is specified as the number of

4-MHz clock cycles. Refer to the [Using the Timer Module](#) section for details.

Figure 76. LED2ENDC: Sample LED2 End Count Register (Address = 02h, Reset Value = 0000h)

23	22	21	20	19	18	17	16	15	14	13	12
0	0	0	0	0	0	0	0	LED2ENDC[15:0]			
11	10	9	8	7	6	5	4	3	2	1	0
LED2ENDC[15:0]											

This register sets the end timing value for the LED2 signal sample.

Bits 23:16 **Must be 0**

Bits 15:0 **LED2ENDC[15:0]: Sample LED2 end count**

The contents of this register can be used to position the end of the sample LED2 signal with respect to the PRP, as specified in the PRPCOUNT register. The count is specified as the number of 4-MHz clock cycles. Refer to the [Using the Timer Module](#) section for details.

Figure 77. LED2LEDSTC: LED2 LED Start Count Register (Address = 03h, Reset Value = 0000h)

23	22	21	20	19	18	17	16	15	14	13	12
0	0	0	0	0	0	0	0	LED2LEDSTC[15:0]			
11	10	9	8	7	6	5	4	3	2	1	0
LED2LEDSTC[15:0]											

This register sets the start timing value for when the LED2 signal turns on.

Bits 23:16 **Must be 0**

Bits 15:0 **LED2LEDSTC[15:0]: LED2 start count**

The contents of this register can be used to position the start of the LED2 with respect to the PRP, as specified in the PRPCOUNT register. The count is specified as the number of 4-MHz clock cycles. Refer to the [Using the Timer Module](#) section for details.

Figure 78. LED2LEDENDC: LED2 LED End Count Register (Address = 04h, Reset Value = 0000h)

23	22	21	20	19	18	17	16	15	14	13	12
0	0	0	0	0	0	0	0	LED2LEDENDC[15:0]			
11	10	9	8	7	6	5	4	3	2	1	0
LED2LEDENDC[15:0]											

This register sets the end timing value for when the LED2 signal turns off.

Bits 23:16 **Must be 0**

Bits 15:0 **LED2LEDENDC[15:0]: LED2 end count**

The contents of this register can be used to position the end of the LED2 signal with respect to the PRP, as specified in the PRPCOUNT register. The count is specified as the number of 4-MHz clock cycles. Refer to the [Using the Timer Module](#) section for details.

Figure 79. ALED2STC: Sample Ambient LED2 Start Count Register (Address = 05h, Reset Value = 0000h)

23	22	21	20	19	18	17	16	15	14	13	12
0	0	0	0	0	0	0	0	ALED2STC[15:0]			
11	10	9	8	7	6	5	4	3	2	1	0
ALED2STC[15:0]											

This register sets the start timing value for the ambient LED2 signal sample.

Bits 23:16
Must be 0
Bits 15:0
ALED2STC[15:0]: Sample ambient LED2 start count

The contents of this register can be used to position the start of the sample ambient LED2 signal with respect to the PRP, as specified in the PRPCOUNT register. The count is specified as the number of 4-MHz clock cycles. Refer to the [Using the Timer Module](#) section for details.

Figure 80. ALED2ENDC: Sample Ambient LED2 End Count Register (Address = 06h, Reset Value = 0000h)

23	22	21	20	19	18	17	16	15	14	13	12
0	0	0	0	0	0	0	0	ALED2ENDC[15:0]			
11	10	9	8	7	6	5	4	3	2	1	0
ALED2ENDC[15:0]											

This register sets the end timing value for the ambient LED2 signal sample.

Bits 23:16
Must be 0
Bits 15:0
ALED2ENDC[15:0]: Sample ambient LED2 end count

The contents of this register can be used to position the end of the sample ambient LED2 signal with respect to the PRP, as specified in the PRPCOUNT register. The count is specified as the number of 4-MHz clock cycles. Refer to the [Using the Timer Module](#) section for details.

Figure 81. LED1STC: Sample LED1 Start Count Register (Address = 07h, Reset Value = 0000h)

23	22	21	20	19	18	17	16	15	14	13	12
0	0	0	0	0	0	0	0	LED1STC[15:0]			
11	10	9	8	7	6	5	4	3	2	1	0
LED1STC[15:0]											

This register sets the start timing value for the LED1 signal sample.

Bits 23:17
Must be 0
Bits 16:0
LED1STC[15:0]: Sample LED1 start count

The contents of this register can be used to position the start of the sample LED1 signal with respect to the PRP, as specified in the PRPCOUNT register. The count is specified as the number of 4-MHz clock cycles. Refer to the [Using the Timer Module](#) section for details.

Figure 82. LED1ENDC: Sample LED1 End Count (Address = 08h, Reset Value = 0000h)

23	22	21	20	19	18	17	16	15	14	13	12
0	0	0	0	0	0	0	0	LED1ENDC[15:0]			
11	10	9	8	7	6	5	4	3	2	1	0
LED1ENDC[15:0]											

This register sets the end timing value for the LED1 signal sample.

Bits 23:17 **Must be 0**

Bits 16:0 **LED1ENDC[15:0]: Sample LED1 end count**

The contents of this register can be used to position the end of the sample LED1 signal with respect to the PRP, as specified in the PRPCOUNT register. The count is specified as the number of 4-MHz clock cycles. Refer to the [Using the Timer Module](#) section for details.

Figure 83. LED1LEDSTC: LED1 LED Start Count Register (Address = 09h, Reset Value = 0000h)

23	22	21	20	19	18	17	16	15	14	13	12
0	0	0	0	0	0	0	0	LED1LEDSTC[15:0]			
11	10	9	8	7	6	5	4	3	2	1	0
LED1LEDSTC[15:0]											

This register sets the start timing value for when the LED1 signal turns on.

Bits 23:16 **Must be 0**

Bits 15:0 **LED1LEDSTC[15:0]: LED1 start count**

The contents of this register can be used to position the start of the LED1 signal with respect to the PRP, as specified in the PRPCOUNT register. The count is specified as the number of 4-MHz clock cycles. Refer to the [Using the Timer Module](#) section for details.

Figure 84. LED1LEDENDC: LED1 LED End Count Register (Address = 0Ah, Reset Value = 0000h)

23	22	21	20	19	18	17	16	15	14	13	12
0	0	0	0	0	0	0	0	LED1LEDENDC[15:0]			
11	10	9	8	7	6	5	4	3	2	1	0
LED1LEDENDC[15:0]											

This register sets the end timing value for when the LED1 signal turns off.

Bits 23:16 **Must be 0**

Bits 15:0 **LED1LEDENDC[15:0]: LED1 end count**

The contents of this register can be used to position the end of the LED1 signal with respect to the PRP, as specified in the PRPCOUNT register. The count is specified as the number of 4-MHz clock cycles. Refer to the [Using the Timer Module](#) section for details.

Figure 85. ALED1STC: Sample Ambient LED1 Start Count Register (Address = 0Bh, Reset Value = 0000h)

23	22	21	20	19	18	17	16	15	14	13	12
0	0	0	0	0	0	0	0	ALED1STC[15:0]			
11	10	9	8	7	6	5	4	3	2	1	0
ALED1STC[15:0]											

This register sets the start timing value for the ambient LED1 signal sample.

Bits 23:16 **Must be 0**

Bits 15:0 **ALED1STC[15:0]: Sample ambient LED1 start count**

The contents of this register can be used to position the start of the sample ambient LED1 signal with respect to the PRP, as specified in the PRPCOUNT register. The count is specified as the number of 4-MHz clock cycles. Refer to the [Using the Timer Module](#) section for details.

Figure 86. ALED1ENDC: Sample Ambient LED1 End Count Register (Address = 0Ch, Reset Value = 0000h)

23	22	21	20	19	18	17	16	15	14	13	12
0	0	0	0	0	0	0	0	ALED1ENDC[15:0]			
11	10	9	8	7	6	5	4	3	2	1	0
ALED1ENDC[15:0]											

This register sets the end timing value for the ambient LED1 signal sample.

Bits 23:16 **Must be 0**

Bits 15:0 **ALED1ENDC[15:0]: Sample ambient LED1 end count**

The contents of this register can be used to position the end of the sample ambient LED1 signal with respect to the PRP, as specified in the PRPCOUNT register. The count is specified as the number of 4-MHz clock cycles. Refer to the [Using the Timer Module](#) section for details.

Figure 87. LED2CONVST: LED2 Convert Start Count Register (Address = 0Dh, Reset Value = 0000h)

23	22	21	20	19	18	17	16	15	14	13	12
0	0	0	0	0	0	0	0	LED2CONVST[15:0]			
11	10	9	8	7	6	5	4	3	2	1	0
LED2CONVST[15:0]											

This register sets the start timing value for the LED2 conversion.

Bits 23:16 **Must be 0**

Bits 15:0 **LED2CONVST[15:0]: LED2 convert start count**

The contents of this register can be used to position the start of the LED2 conversion signal with respect to the PRP, as specified in the PRPCOUNT register. The count is specified as the number of 4-MHz clock cycles. Refer to the [Using the Timer Module](#) section for details.

Figure 88. LED2CONVEND: LED2 Convert End Count Register (Address = 0Eh, Reset Value = 0000h)

23	22	21	20	19	18	17	16	15	14	13	12
0	0	0	0	0	0	0	0	LED2CONVEND[15:0]			
11	10	9	8	7	6	5	4	3	2	1	0
LED2CONVEND[15:0]											

This register sets the end timing value for the LED2 conversion.

Bits 23:16 **Must be 0**

Bits 15:0 **LED2CONVEND[15:0]: LED2 convert end count**

The contents of this register can be used to position the end of the LED2 conversion signal with respect to the PRP, as specified in the PRPCOUNT register. The count is specified as the number of 4-MHz clock cycles. Refer to the [Using the Timer Module](#) section for details.

Figure 89. ALED2CONVST: LED2 Ambient Convert Start Count Register (Address = 0Fh, Reset Value = 0000h)

23	22	21	20	19	18	17	16	15	14	13	12
0	0	0	0	0	0	0	0	ALED2CONVST[15:0]			
11	10	9	8	7	6	5	4	3	2	1	0
ALED2CONVST[15:0]											

This register sets the start timing value for the ambient LED2 conversion.

Bits 23:16 **Must be 0**

Bits 15:0 **ALED2CONVST[15:0]: LED2 ambient convert start count**

The contents of this register can be used to position the start of the LED2 ambient conversion signal with respect to the PRP, as specified in the PRPCOUNT register. The count is specified as the number of 4-MHz clock cycles. Refer to the [Using the Timer Module](#) section for details.

Figure 90. ALED2CONVEND: LED2 Ambient Convert End Count Register (Address = 10h, Reset Value = 0000h)

23	22	21	20	19	18	17	16	15	14	13	12
0	0	0	0	0	0	0	0	ALED2CONVEND[15:0]			
11	10	9	8	7	6	5	4	3	2	1	0
ALED2CONVEND[15:0]											

This register sets the end timing value for the ambient LED2 conversion.

Bits 23:16 **Must be 0**

Bits 15:0 **ALED2CONVEND[15:0]: LED2 ambient convert end count**

The contents of this register can be used to position the end of the LED2 ambient conversion signal with respect to the PRP. The count is specified as the number of 4-MHz clock cycles. Refer to the [Using the Timer Module](#) section for details.

Figure 91. LED1CONVST: LED1 Convert Start Count Register (Address = 11h, Reset Value = 0000h)

23	22	21	20	19	18	17	16	15	14	13	12
0	0	0	0	0	0	0	0	LED1CONVST[15:0]			
11	10	9	8	7	6	5	4	3	2	1	0
LED1CONVST[15:0]											

This register sets the start timing value for the LED1 conversion.

Bits 23:16 **Must be 0**

Bits 15:0 **LED1CONVST[15:0]: LED1 convert start count**

The contents of this register can be used to position the start of the LED1 conversion signal with respect to the PRP, as specified in the PRPCOUNT register. The count is specified as the number of 4-MHz clock cycles. Refer to the [Using the Timer Module](#) section for details.

Figure 92. LED1CONVEND: LED1 Convert End Count Register (Address = 12h, Reset Value = 0000h)

23	22	21	20	19	18	17	16	15	14	13	12
0	0	0	0	0	0	0	0	LED1CONVEND[15:0]			
11	10	9	8	7	6	5	4	3	2	1	0
LED1CONVEND[15:0]											

This register sets the end timing value for the LED1 conversion.

Bits 23:16 **Must be 0**

Bits 15:0 **LED1CONVEND[15:0]: LED1 convert end count**

The contents of this register can be used to position the end of the LED1 conversion signal with respect to the PRP. The count is specified as the number of 4-MHz clock cycles. Refer to the [Using the Timer Module](#) section for details.

Figure 93. ALED1CONVST: LED1 Ambient Convert Start Count Register (Address = 13h, Reset Value = 0000h)

23	22	21	20	19	18	17	16	15	14	13	12
0	0	0	0	0	0	0	0	ALED1CONVST[15:0]			
11	10	9	8	7	6	5	4	3	2	1	0
ALED1CONVST[15:0]											

This register sets the start timing value for the ambient LED1 conversion.

Bits 23:16 **Must be 0**

Bits 15:0 **ALED1CONVST[15:0]: LED1 ambient convert start count**

The contents of this register can be used to position the start of the LED1 ambient conversion signal with respect to the PRP, as specified in the PRPCOUNT register. The count is specified as the number of 4-MHz clock cycles. Refer to the [Using the Timer Module](#) section for details.

Figure 94. ALED1CONVEND: LED1 Ambient Convert End Count Register (Address = 14h, Reset Value = 0000h)

23	22	21	20	19	18	17	16	15	14	13	12
0	0	0	0	0	0	0	0	ALED1CONVEND[15:0]			
11	10	9	8	7	6	5	4	3	2	1	0
ALED1CONVEND[15:0]											

This register sets the end timing value for the ambient LED1 conversion.

Bits 23:16 **Must be 0**

Bits 15:0 **ALED1CONVEND[15:0]: LED1 ambient convert end count**

The contents of this register can be used to position the end of the LED1 ambient conversion signal with respect to the PRP. The count is specified as the number of 4-MHz clock cycles. Refer to the [Using the Timer Module](#) section for details.

Figure 95. ADCRSTSTCT0: ADC Reset 0 Start Count Register (Address = 15h, Reset Value = 0000h)

23	22	21	20	19	18	17	16	15	14	13	12
0	0	0	0	0	0	0	0	ADCRSTSTCT0[15:0]			
11	10	9	8	7	6	5	4	3	2	1	0
ADCRSTSTCT0[15:0]											

This register sets the start position of the ADC0 reset conversion signal.

Bits 23:16 **Must be 0**

Bits 15:0 **ADCRSTSTCT0[15:0]: ADC RESET 0 start count**

The contents of this register can be used to position the start of the ADC reset conversion signal (default value after reset is 0000h). Refer to the [Using the Timer Module](#) section for details.

Figure 96. ADCRSTENDCT0: ADC Reset 0 End Count Register (Address = 16h, Reset Value = 0000h)

23	22	21	20	19	18	17	16	15	14	13	12
0	0	0	0	0	0	0	0	ADCRSTENDCT0[15:0]			
11	10	9	8	7	6	5	4	3	2	1	0
ADCRSTENDCT0[15:0]											

This register sets the end position of the ADC0 reset conversion signal.

Bits 23:16 **Must be 0**

Bits 15:0 **ADCRSTENDCT0[15:0]: ADC RESET 0 end count**

The contents of this register can be used to position the end of the ADC reset conversion signal (default value after reset is 0000h). Refer to the [Using the Timer Module](#) section for details.

Figure 97. ADCRSTSTCT1: ADC Reset 1 Start Count Register (Address = 17h, Reset Value = 0000h)

23	22	21	20	19	18	17	16	15	14	13	12
0	0	0	0	0	0	0	0	ADCRSTSTCT1[15:0]			
11	10	9	8	7	6	5	4	3	2	1	0
ADCRSTSTCT1[15:0]											

This register sets the start position of the ADC1 reset conversion signal.

Bits 23:16 **Must be 0**

Bits 15:0 **ADCRSTSTCT1[15:0]: ADC RESET 1 start count**

The contents of this register can be used to position the start of the ADC reset conversion. Refer to the [Using the Timer Module](#) section for details.

Figure 98. ADCRSTENDCT1: ADC Reset 1 End Count Register (Address = 18h, Reset Value = 0000h)

23	22	21	20	19	18	17	16	15	14	13	12
0	0	0	0	0	0	0	0	ADCRSTENDCT1[15:0]			
11	10	9	8	7	6	5	4	3	2	1	0
ADCRSTENDCT1[15:0]											

This register sets the end position of the ADC1 reset conversion signal.

Bits 23:16 **Must be 0**

Bits 15:0 **ADCRSTENDCT1[15:0]: ADC RESET 1 end count**

The contents of this register can be used to position the end of the ADC reset conversion. Refer to the [Using the Timer Module](#) section for details.

Figure 99. ADCRSTSTCT2: ADC Reset 2 Start Count Register (Address = 19h, Reset Value = 0000h)

23	22	21	20	19	18	17	16	15	14	13	12
0	0	0	0	0	0	0	0	ADCRSTSTCT2[15:0]			
11	10	9	8	7	6	5	4	3	2	1	0
ADCRSTSTCT2[15:0]											

This register sets the start position of the ADC2 reset conversion signal.

Bits 23:16 **Must be 0**

Bits 15:0 **ADCRSTSTCT2[15:0]: ADC RESET 2 start count**

The contents of this register can be used to position the start of the ADC reset conversion. Refer to the [Using the Timer Module](#) section for details.

Figure 100. ADCRSTENDCT2: ADC Reset 2 End Count Register (Address = 1Ah, Reset Value = 0000h)

23	22	21	20	19	18	17	16	15	14	13	12
0	0	0	0	0	0	0	0	ADCRSTENDCT2[15:0]			
11	10	9	8	7	6	5	4	3	2	1	0
ADCRSTENDCT2[15:0]											

This register sets the end position of the ADC2 reset conversion signal.

Bits 23:16 **Must be 0**

Bits 15:0 **ADCRSTENDCT2[15:0]: ADC RESET 2 end count**

The contents of this register can be used to position the end of the ADC reset conversion. Refer to the [Using the Timer Module](#) section for details.

Figure 101. ADCRSTSTCT3: ADC Reset 3 Start Count Register (Address = 1Bh, Reset Value = 0000h)

23	22	21	20	19	18	17	16	15	14	13	12
0	0	0	0	0	0	0	0	ADCRSTSTCT3[15:0]			
11	10	9	8	7	6	5	4	3	2	1	0
ADCRSTSTCT3[15:0]											

This register sets the start position of the ADC3 reset conversion signal.

Bits 23:16 **Must be 0**

Bits 15:0 **ADCRSTSTCT3[15:0]: ADC RESET 3 start count**

The contents of this register can be used to position the start of the ADC reset conversion. Refer to the [Using the Timer Module](#) section for details.

Figure 102. ADCRSTENDCT3: ADC Reset 3 End Count Register (Address = 1Ch, Reset Value = 0000h)

23	22	21	20	19	18	17	16	15	14	13	12
0	0	0	0	0	0	0	0	ADCRSTENDCT3[15:0]			
11	10	9	8	7	6	5	4	3	2	1	0
ADCRSTENDCT3[15:0]											

This register sets the end position of the ADC3 reset conversion signal.

Bits 23:16 **Must be 0**

Bits 15:0 **ADCRSTENDCT3[15:0]: ADC RESET 3 end count**

The contents of this register can be used to position the end of the ADC reset conversion signal (default value after reset is 0000h). Refer to the [Using the Timer Module](#) section for details.

Figure 103. PRPCOUNT: Pulse Repetition Period Count Register (Address = 1Dh, Reset Value = 0000h)

23	22	21	20	19	18	17	16	15	14	13	12
0	0	0	0	0	0	0	0	PRPCOUNT[15:0]			
11	10	9	8	7	6	5	4	3	2	1	0
PRPCOUNT[15:0]											

This register sets the device pulse repetition period count.

Bits 23:16 **Must be 0**

Bits 15:0 **PRPCOUNT[15:0]: Pulse repetition period count**

The contents of this register can be used to set the pulse repetition period (in number of clock cycles of the 4-MHz clock). The PRPCOUNT value must be set in the range of 800 to 64000. Values below 800 do not allow sufficient sample time for the four samples; see the [Electrical Characteristics](#) table.

Figure 104. CONTROL1: Control Register 1 (Address = 1Eh, Reset Value = 0000h)

23	22	21	20	19	18	17	16	15	14	13	12	
0	0	0	0	0	0	0	0	0	0	0	0	
11	10	9	8	7	6	5	4	3	2	1	0	
0	0	0	TIMEREN	NUMAV[7:0]							0	0

This register configures the clock alarm pin and timer.

Bits 23:9 **Must be 0**

Bit 8 **TIMEREN: Timer enable**

0 = Timer module is disabled and all internal clocks are off (default after reset)
1 = Timer module is enabled

Bits 7:0 **NUMAV[7:0]: Number of averages**

Specify an 8-bit value corresponding to the number of ADC samples to be averaged – 1. For example, to average four ADC samples, set NUMAV[7:0] equal to 3. The maximum number of averages is 16. Any setting of NUMAV[7:0] greater than or equal to a decimal value of 15 results in the number of averages getting set to 16.

Figure 105. SPARE1: SPARE1 Register For Future Use (Address = 1Fh, Reset Value = 0000h)

23	22	21	20	19	18	17	16	15	14	13	12
0	0	0	0	0	0	0	0	0	0	0	0
11	10	9	8	7	6	5	4	3	2	1	0
0	0	0	0	0	0	0	0	0	0	0	0

This register is a spare register and is reserved for future use.

Bits 23:0 **Must be 0**

**Figure 106. TIAGAIN: Transimpedance Amplifier Gain Setting Register
(Address = 20h, Reset Value = 0000h)**

23	22	21	20	19	18	17	16	15	14	13	12	
0	0	0	0	0	0	0	0	ENSEP GAIN	STAGE2 EN1	0	0	
11	10	9	8	7	6	5	4	3	2	1	0	
0			STG2GAIN1[2:0]				CF_LED1[4:0]			RF_LED1[2:0]		

This register sets the device transimpedance amplifier gain mode and feedback resistor and capacitor values.

Bits 23:16 **Must be 0**

Bit 15 **ENSEPGAIN: Enable separate gain mode**

0 = The R_F , C_F values and stage 2 gain settings are the same for both the LED2 and LED1 signals; the values are specified by the bits (RF_LED2, CF_LED2, STAGE2EN2, STG2GAIN2) in the TIA_AMB_GAIN register (default after reset)

1 = The R_F , C_F values and stage 2 gain settings can be independently set for the LED2 and LED1 signals. The values for LED1 are specified using the bits (RF_LED1, CF_LED1, STAGE2EN1, STG2GAIN1) in the TIAGAIN register, whereas the values for LED2 are specified using the corresponding bits in the TIA_AMB_GAIN register.

Bit 14 **STAGE2EN1: Enable stage 2 for LED 1**

0 = Stage 2 is bypassed (default after reset)

1 = Stage 2 is enabled with the gain value specified by the STG2GAIN1[2:0] bits

Bits 13:11 **Must be 0**

Bits 10:8 **STG2GAIN1[2:0]: Program stage 2 gain for LED1**

000 = 0 dB, or linear gain of 1 (default after reset)

001 = 3.5 dB, or linear gain of 1.5

010 = 6 dB, or linear gain of 2

011 = 9.5 dB, or linear gain of 3

100 = 12 dB, or linear gain of 4

101 = Do not use

110 = Do not use

111 = Do not use

Bits 7:3 **CF_LED1[4:0]: Program C_F for LED1**

00000 = 5 pF (default after reset)

00001 = 5 pF + 5 pF

00010 = 15 pF + 5 pF

00100 = 25 pF + 5 pF

01000 = 50 pF + 5 pF

10000 = 150 pF + 5 pF

Note that any combination of these C_F settings is also supported by setting multiple bits to 1. For example, to obtain $C_F = 100$ pF, set bits 7:3 = 01111.

Bits 2:0 **RF_LED1[2:0]: Program R_F for LED1**

000 = 500 k Ω (default after reset)

001 = 250 k Ω

010 = 100 k Ω

011 = 50 k Ω

100 = 25 k Ω

101 = 10 k Ω

110 = 1 M Ω

111 = None

**Figure 107. TIA_AMB_GAIN: Transimpedance Amplifier and Ambient Cancellation Stage Gain Register
(Address = 21h, Reset Value = 0000h)**

23	22	21	20	19	18	17	16	15	14	13	12
0	0	0	0	AMBDAC[3:0]				FLTR CNRSEL	STAGE2 EN2	0	0
11	10	9	8	7	6	5	4	3	2	1	0
0	STG2GAIN[2:0]			CF_LED2[4:0]				RF_LED2[2:0]			

This register configures the ambient light cancellation amplifier gain, cancellation current, and filter corner frequency.

Bits 23:20 **Must be 0**

Bits 19:16 **AMBDAC[3:0]: Ambient DAC value**

These bits set the value of the cancellation current.

0000 = 0 μ A (default after reset)	1000 = 8 μ A
0001 = 1 μ A	1001 = 9 μ A
0010 = 2 μ A	1010 = 10 μ A
0011 = 3 μ A	1011 = Do not use
0100 = 4 μ A	1100 = Do not use
0101 = 5 μ A	1101 = Do not use
0110 = 6 μ A	1110 = Do not use
0111 = 7 μ A	1111 = Do not use

Bit 15 **Must be 0**

Bit 14 **STAGE2EN2: Stage 2 enable for LED 2**

0 = Stage 2 is bypassed (default after reset)
1 = Stage 2 is enabled with the gain value specified by the STG2GAIN2[2:0] bits

Bits 13:11 **Must be 0**

Bits 10:8 **STG2GAIN2[2:0]: Stage 2 gain setting for LED 2**

000 = 0 dB, or linear gain of 1 (default after reset)
001 = 3.5 dB, or linear gain of 1.5
010 = 6 dB, or linear gain of 2
011 = 9.5 dB, or linear gain of 3
100 = 12 dB, or linear gain of 4
101 = Do not use
110 = Do not use
111 = Do not use

Bits 7:3 **CF_LED[4:0]: Program C_F for LEDs**

00000 = 5 pF (default after reset)	00100 = 25 pF + 5 pF
00001 = 5 pF + 5 pF	01000 = 50 pF + 5 pF
00010 = 15 pF + 5 pF	10000 = 150 pF + 5 pF

Note that any combination of these C_F settings is also supported by setting multiple bits to 1. For example, to obtain $C_F = 100$ pF, set D[7:3] = 01111.

Bits 2:0 **RF_LED[2:0]: Program R_F for LEDs**

000 = 500 k Ω	100 = 25 k Ω
001 = 250 k Ω	101 = 10 k Ω
010 = 100 k Ω	110 = 1 M Ω
011 = 50 k Ω	111 = None

Figure 108. LEDCNTRL: LED Control Register (Address = 22h, Reset Value = 0000h)

23	22	21	20	19	18	17	16	15	14	13	12
0	0	0	0	0	0	LED_RANGE[1:0]		LED1[7:0]			
11	10	9	8	7	6	5	4	3	2	1	0
LED1[7:0]						LED2[7:0]					

This register sets the LED current range and the LED1 and LED2 drive current.

Bits 23:18 **Must be 0**

Bits 17:16 **LED_RANGE[1:0]: LED range**

These bits program the full-scale LED current range for Tx. [Table 7](#) details the settings.

Bits 15:8 **LED1[7:0]: Program LED current for LED1 signal**

Use these register bits to specify the LED current setting for LED1 (default after reset is 00h).

The nominal value of the LED current is given by [Equation 7](#), where the full-scale LED current is either 0 mA or 50 mA (as specified by the LED_RANGE[1:0] register bits).

Bits 7:0 **LED2[7:0]: Program LED current for LED2 signal**

Use these register bits to specify the LED current setting for LED2 (default after reset is 00h).

The nominal value of LED current is given by [Equation 8](#), where the full-scale LED current is either 0 mA or 50 mA (as specified by the LED_RANGE[1:0] register bits).

Table 7. Full-Scale LED Current across Tx Reference Voltage Settings⁽¹⁾

LED_RANGE[1:0]	TX_REF = 0.25 V		TX_REF = 0.5 V		TX_REF = 0.75 V		TX_REF = 1.0 V	
	I _{MAX}	V _{HR} ⁽²⁾	I _{MAX}	V _{HR}	I _{MAX}	V _{HR}	I _{MAX}	V _{HR}
00 (default after reset)	50 mA	0.75 V	100 mA	1.1 V	Do not use	—	Do not use	—
01	25 mA	0.7 V	50 mA	1.0 V	75 mA	1.3 V	100 mA	1.6 V
10	50 mA	0.75 V	100 mA	1.1 V	Do not use	—	Do not use	—
11	Tx is off	—	Tx is off	—	Tx is off	—	Tx is off	—

(1) For a 3-V to 3.6-V supply, use TX_REF = 0.25 or 0.5 V. For a 4.75-V to 5.25-V supply, use TX_REF = 0.75 V or 1.0 V.

(2) V_{HR} refers to the headroom voltage (over and above the LED forward voltage and cable voltage drop) needed on the LED_DRV_SUP. The V_{HR} values specified are for the H-bridge configuration. In the common anode configuration, V_{HR} can be lower by 0.25 V.

$$\frac{\text{LED1}[7:0]}{256} \times \text{Full-Scale Current} \quad (7)$$

$$\frac{\text{LED2}[7:0]}{256} \times \text{Full-Scale Current} \quad (8)$$

Figure 109. CONTROL2: Control Register 2 (Address = 23h, Reset Value = 0000h)

23	22	21	20	19	18	17	16	15	14	13	12
0	0	0	DYNAMI C1	0	TX_REF1	TX_REF0	0	0	DYNAMI C2	0	0
11	10	9	8	7	6	5	4	3	2	1	0
TXBRG MOD	DIGOUT_ TRI STATE	XTAL DIS	EN_ SLOW_ DIAG	0	0	0	DYNAMI C3	DYNAMI C4	PDNTX	PDNRX	PDNAFE

This register controls the LED transmitter, crystal, and the AFE, transmitter, and receiver power modes.

Bits 23:21 **Must be 0**

Bit 20 **DYNAMIC1**

0 = Transmitter is not powered down during dynamic power-down phase
1 = Transmitter is powered down during dynamic power-down phase

Bit 19 **Must be 0**

Bits 18:17 **TX_REF[1:0]: Tx reference voltage**

These bits set the transmitter reference voltage. This Tx reference voltage is available on the device TX_REF pin.

00 = 0.25-V Tx reference voltage (default value after reset)
01 = 0.5-V Tx reference voltage
10 = 1.0-V Tx reference voltage
11 = 0.75-V Tx reference voltage, D3

Bits 16:15 **Must be 0**

Bit 14 **DYNAMIC2**

0 = Part of the ADC is not powered down during dynamic power-down phase
1 = Part of the ADC is powered down during dynamic power-down phase

Bit 11 **TXBRGMOD: Tx bridge mode**

0 = LED driver is configured as an H-bridge (default after reset)
1 = LED driver is configured as a push-pull

Bit 10 **DIGOUT_TRISTATE: Tri-state bit for the ADC_RDY and DIAG_END pins**

0 = ADC_RDY and DIAG_END are not tri-stated
1 = ADC_RDY and DIAG_END are tri-stated

Bit 9 **XTALDIS: Crystal disable mode**

0 = The crystal module is enabled; the 8-MHz crystal must be connected to the XIN and XOUT pins
1 = The crystal module is disabled; an external 8-MHz clock must be applied to the XIN pin

Bit 8 **EN_SLOW_DIAG: Fast diagnostics mode enable**

0 = Fast diagnostics mode, 8 ms (default value after reset)
1 = Slow diagnostics mode, 16 ms

Bits 7:5 **Must be 0**

Bit 4 **DYNAMIC3**

0 = TIA is not powered down during dynamic power-down phase
1 = TIA is powered down during dynamic power-down phase

Bit 3 **DYNAMIC4**

0 = The rest of the ADC is not powered down during dynamic power-down phase
1 = The rest of the ADC is powered down during dynamic power-down phase

- Bit 2** **PDN_TX: Tx power-down**
 0 = The Tx is powered up (default after reset)
 1 = Only the Tx module is powered down
- Bit 1** **PDN_RX: Rx power-down**
 0 = The Rx is powered up (default after reset)
 1 = Only the Rx module is powered down
- Bit 0** **PDN_AFE: AFE power-down**
 0 = The AFE is powered up (default after reset)
 1 = The entire AFE is powered down (including the Tx, Rx, and diagnostics blocks)

Figure 110. SPARE2: SPARE2 Register For Future Use (Address = 24h, Reset Value = 0000h)

23	22	21	20	19	18	17	16	15	14	13	12
0	0	0	0	0	0	0	0	0	0	0	0
11	10	9	8	7	6	5	4	3	2	1	0
0	0	0	0	0	0	0	0	0	0	0	0

This register is a spare register and is reserved for future use.

Bits 23:0 **Must be 0**

Figure 111. SPARE3: SPARE3 Register For Future Use (Address = 25h, Reset Value = 0000h)

23	22	21	20	19	18	17	16	15	14	13	12
0	0	0	0	0	0	0	0	0	0	0	0
11	10	9	8	7	6	5	4	3	2	1	0
0	0	0	0	0	0	0	0	0	0	0	0

This register is a spare register and is reserved for future use.

Bits 23:0 **Must be 0**

Figure 112. SPARE4: SPARE4 Register For Future Use (Address = 26h, Reset Value = 0000h)

23	22	21	20	19	18	17	16	15	14	13	12
0	0	0	0	0	0	0	0	0	0	0	0
11	10	9	8	7	6	5	4	3	2	1	0
0	0	0	0	0	0	0	0	0	0	0	0

This register is a spare register and is reserved for future use.

Bits 23:0 **Must be 0**

Figure 113. RESERVED1: RESERVED1 Register For Factory Use Only (Address = 27h, Reset Value = XXXXh)

23	22	21	20	19	18	17	16	15	14	13	12
X ⁽¹⁾	X	X	X	X	X	X	X	X	X	X	X
11	10	9	8	7	6	5	4	3	2	1	0
X	X	X	X	X	X	X	X	X	X	X	X

(1) X = don't care.

This register is reserved for factory use. Readback values vary between devices.

**Figure 114. RESERVED2: RESERVED2 Register For Factory Use Only
(Address = 28h, Reset Value = XXXXh)**

23	22	21	20	19	18	17	16	15	14	13	12
X ⁽¹⁾	X	X	X	X	X	X	X	X	X	X	X
11	10	9	8	7	6	5	4	3	2	1	0
X	X	X	X	X	X	X	X	X	X	X	X

(1) X = don't care.

This register is reserved for factory use. Readback values vary between devices.

Figure 115. ALARM: Alarm Register (Address = 29h, Reset Value = 0000h)

23	22	21	20	19	18	17	16	15	14	13	12
0	0	0	0	0	0	0	0	0	0	0	0
11	10	9	8	7	6	5	4	3	2	1	0
0	0	0	0	0	0	0	0	0	0	0	0

This register controls the alarm pin functionality.

Bits 23:0 Must be 0

Figure 116. LED2VAL: LED2 Digital Sample Value Register (Address = 2Ah, Reset Value = 0000h)

23	22	21	20	19	18	17	16	15	14	13	12
LED2VAL[23:0]											
11	10	9	8	7	6	5	4	3	2	1	0
LED2VAL[23:0]											

Bits 23:0 LED2VAL[23:0]: LED2 digital value

This register contains the digital value of the latest LED2 sample converted by the ADC. The ADC_RDY signal goes high each time that the contents of this register are updated. The host processor must readout this register before the next sample is converted by the AFE.

**Figure 117. ALED2VAL: Ambient LED2 Digital Sample Value Register
(Address = 2Bh, Reset Value = 0000h)**

23	22	21	20	19	18	17	16	15	14	13	12
ALED2VAL[23:0]											
11	10	9	8	7	6	5	4	3	2	1	0
ALED2VAL[23:0]											

Bits 23:0 ALED2VAL[23:0]: LED2 ambient digital value

This register contains the digital value of the latest LED2 ambient sample converted by the ADC. The ADC_RDY signal goes high each time that the contents of this register are updated. The host processor must readout this register before the next sample is converted by the AFE.

Figure 118. LED1VAL: LED1 Digital Sample Value Register (Address = 2Ch, Reset Value = 0000h)

23	22	21	20	19	18	17	16	15	14	13	12
LED1VAL[23:0]											
11	10	9	8	7	6	5	4	3	2	1	0
LED1VAL[23:0]											

Bits 23:0 LED1VAL[23:0]: LED1 digital value

This register contains the digital value of the latest LED1 sample converted by the ADC. The ADC_RDY signal goes high each time that the contents of this register are updated. The host processor must readout this register before the next sample is converted by the AFE.

Figure 119. ALED1VAL: Ambient LED1 Digital Sample Value Register (Address = 2Dh, Reset Value = 0000h)

23	22	21	20	19	18	17	16	15	14	13	12
ALED1VAL[23:0]											
11	10	9	8	7	6	5	4	3	2	1	0
ALED1VAL[23:0]											

Bits 23:0 ALED1VAL[23:0]: LED1 ambient digital value

This register contains the digital value of the latest LED1 ambient sample converted by the ADC. The ADC_RDY signal goes high each time that the contents of this register are updated. The host processor must readout this register before the next sample is converted by the AFE.

Figure 120. LED2-ALED2VAL: LED2-Ambient LED2 Digital Sample Value Register (Address = 2Eh, Reset Value = 0000h)

23	22	21	20	19	18	17	16	15	14	13	12
LED2-ALED2VAL[23:0]											
11	10	9	8	7	6	5	4	3	2	1	0
LED2-ALED2VAL[23:0]											

Bits 23:0 LED2-ALED2VAL[23:0]: (LED2 – LED2 ambient) digital value

This register contains the digital value of the LED2 sample after the LED2 ambient is subtracted. The host processor must readout this register before the next sample is converted by the AFE.

Note that this value is inverted when compared to waveforms shown in many publications.

Figure 121. LED1-ALED1VAL: LED1-Ambient LED1 Digital Sample Value Register (Address = 2Fh, Reset Value = 0000h)

23	22	21	20	19	18	17	16	15	14	13	12
LED1-ALED1VAL[23:0]											
11	10	9	8	7	6	5	4	3	2	1	0
LED1-ALED1VAL[23:0]											

Bits 23:0 LED1-ALED1VAL[23:0]: (LED1 – LED1 ambient) digital value

This register contains the digital value of the LED1 sample after the LED1 ambient is subtracted from it. The host processor must readout this register before the next sample is converted by the AFE.

Note that this value is inverted when compared to waveforms shown in many publications.

Figure 122. DIAG: Diagnostics Flag Register (Address = 30h, Reset Value = 0000h)

23	22	21	20	19	18	17	16	15	14	13	12
0	0	0	0	0	0	0	0	0	0	0	PD_ALM
11	10	9	8	7	6	5	4	3	2	1	0
LED_ALM	LED2_OPEN	LED1_OPEN	LEDSC	OUTNSH_GND	OUTPSH_GND	PDOC	PDSC	INNSC_GND	INPSC_GND	INNSC_LED	INPSC_LED

This register is read only. This register contains the status of all diagnostic flags at the end of the diagnostics sequence. The end of the diagnostics sequence is indicated by the signal going high on DIAG_END pin.

Bits 23:13
Read only
Bit 12
PD_ALM: Power-down alarm status diagnostic flag

This bit indicates the status of PD_ALM .

0 = No fault (default after reset)

1 = Fault present

Bit 11
LED_ALM: LED alarm status diagnostic flag

This bit indicates the status of LED_ALM .

0 = No fault (default after reset)

1 = Fault present

Bit 10
LED2OPEN: LED2 open diagnostic flag

This bit indicates that LED2 is open.

0 = No fault (default after reset)

1 = Fault present

Bit 9
LED1OPEN: LED1 open diagnostic flag

This bit indicates that LED1 is open.

0 = No fault (default after reset)

1 = Fault present

This bit indicates that LED2 is open.

0 = No fault (default after reset)

1 = Fault present

Bit 8
LEDSC: LED short diagnostic flag

This bit indicates an LED short.

0 = No fault (default after reset)

1 = Fault present

Bit 7
OUTNSHGND: OUTN to GND diagnostic flag

This bit indicates that OUTN is shorted to the GND cable.

0 = No fault (default after reset)

1 = Fault present

Bit 6
OUTPSHGND: OUTP to GND diagnostic flag

This bit indicates that OUTP is shorted to the GND cable.

0 = No fault (default after reset)

1 = Fault present

Bit 5
PDOC: PD open diagnostic flag

This bit indicates that PD is open.

0 = No fault (default after reset)

1 = Fault present

- Bit 4** **PDSC: PD short diagnostic flag**
This bit indicates a PD short.
0 = No fault (default after reset)
1 = Fault present
- Bit 3** **INNSCGND: INN to GND diagnostic flag**
This bit indicates a short from the INN pin to the GND cable.
0 = No fault (default after reset)
1 = Fault present
- Bit 2** **INPSCGND: INP to GND diagnostic flag**
This bit indicates a short from the INP pin to the GND cable.
0 = No fault (default after reset)
1 = Fault present
- Bit 1** **INNSCLED: INN to LED diagnostic flag**
This bit indicates a short from the INN pin to the LED cable.
0 = No fault (default after reset)
1 = Fault present
- Bit 0** **INPSCLED: INP to LED diagnostic flag**
This bit indicates a short from the INP pin to the LED cable.
0 = No fault (default after reset)
1 = Fault present

Figure 123. CONTROL3: Control Register (Address = 31h, Reset Value = 0000h)

23	22	21	20	19	18	17	16	15	14	13	12
0	0	0	0	0	0	0	0	TX3_MODE	0	0	0
11	10	9	8	7	6	5	4	3	2	1	0
0	0	0	0	0	0	0	SOMI_TRI	CLKOUT_TRI	CLKDIV[2:0]		

This register controls the clock divider ratio.

Bits 23:16 **Must be 0**

Bit 15 **TX3_MODE: Selection of third LED**

This bit transitions the control from the default two LEDs (on TXP, TXN) to the third LED on TX3.

0 = LEDs on TXP, TXN are active

1 = LED on TX3 is active. Timing engine controls on TXP are transferred to TX3. Maximum current setting supported for the third LED is 50 mA.

Bits 14:5 **Must be 0**

Bit 4 **SOMI_TRI: Serial data output 3-state mode**

This bit determines the state of the SPISOMI output pin. In order to avoid loading the SPI bus when multiple devices are connected, this bit must be set to 1 (3-state mode) whenever the device SPI is inactive.

0 = SPISOMI output buffer is active (normal operation, default)

1 = SPISOMI output buffer is in 3-state mode

Bit 3 **CLKOUT_TRI: CLKOUT output 3-state mode**

This bit determines the state of the CLKOUT output pin.

0 = CLKOUT buffer is active (normal operation, default)

1 = CLKOUT buffer is in 3-state mode

Bits 2:0 **CLKDIV[2:0]: Clock divider ratio**

These bits set the ratio of the clock divider and determine the frequency of CLKOUT relative to the input clock frequency.

[Table 8](#) shows the clock divider ratio settings.

Table 8. Clock Divider Ratio Settings

CLKDIV[2:0]	DIVIDER RATIO	INPUT CLOCK FREQUENCY RANGE
000	Divide-by-2	8 MHz to 12 MHz ⁽¹⁾
001	Do not use	Do not use
010	Divide-by-4	16 MHz to 24 MHz ⁽¹⁾
011	Divide-by-6	24 MHz to 36 MHz
100	Divide-by-8	32 MHz to 48 MHz
101	Divide-by-12	48 MHz to 60 MHz
110	Do not use	Do not use
111	Divide by 1 ⁽²⁾	4 MHz to 6 MHz

(1) These frequency ranges can be used when generating the clock using the crystal.

(2) When using divide-by-1, the external clock should have a duty cycle between 48% to 52%.

Figure 124. PDNCYCLESCTC: PDNCYCLESCTC Register (Address = 32h, Reset Value = 0000h)

23	22	21	20	19	18	17	16	15	14	13	12
0	0	0	0	0	0	0	0	PDNCYCLESCTC[15:0]			
11	10	9	8	7	6	5	4	3	2	1	0
PDNCYCLESCTC[15:0]											

Bits 23:16 **Must be 0**

Bits 15:0 **PDNCYCLESCTC[15:0]: Dynamic (cycle-to-cycle) power-down start count**

The contents of this register can be used to position the start of the PDN_CYCLE signal with respect to the pulse repetition period (PRP). The count is specified as the number of cycles of CLKOUT. If the dynamic power-down feature is not required, then do not program this register.

Figure 125. PDNCYCLESENDC: PDNCYCLESENDC Register (Address = 33h, Reset Value = 0000h)

23	22	21	20	19	18	17	16	15	14	13	12
0	0	0	0	0	0	0	0	PDNCYCLESENDC[15:0]			
11	10	9	8	7	6	5	4	3	2	1	0
PDNCYCLESENDC[15:0]											

Bits 23:16 **Must be 0**

Bits 15:0 **PDNCYCLESENDC[15:0]: Dynamic (cycle-to-cycle) power-down end count**

The contents of this register can be used to position the end of the PDN_CYCLE signal with respect to the pulse repetition period (PRP). The count is specified as the number of cycles of CLKOUT. If the dynamic power-down feature is not required, then do not program this register.

9 Application and Implementation

9.1 Application Information

The AFE4403 is ideally suited as an analog front-end for processing PPG (photoplethysmography) signals. The information contained in PPG signals can be used for measuring SPO2 as well as for monitoring heart rate. The high dynamic range of the device enables measuring SPO2 with a high degree of accuracy, even under conditions of low perfusion (ac:dc ratio). An SPO2 measurement system involves two different wavelength LEDs: usually Red and IR. By computing the ratio of the ac:dc at the two different wavelengths, SPO2 can be calculated. Heart rate monitoring systems can also benefit from the high dynamic range of the AFE4403, which enables a high-fidelity pulsating signal to be captured, even in cases where the signal strength is low.

9.2 Typical Application

Device connections in a typical application is shown in [Figure 126](#). The schematic shows a cabled application in which the LEDs and photodiode are connected to the device through a cable. However, in an application without cables, the LEDs and photodiode can be directly connected to the TXP, TXN, TX3, INP, and INN pins directly.

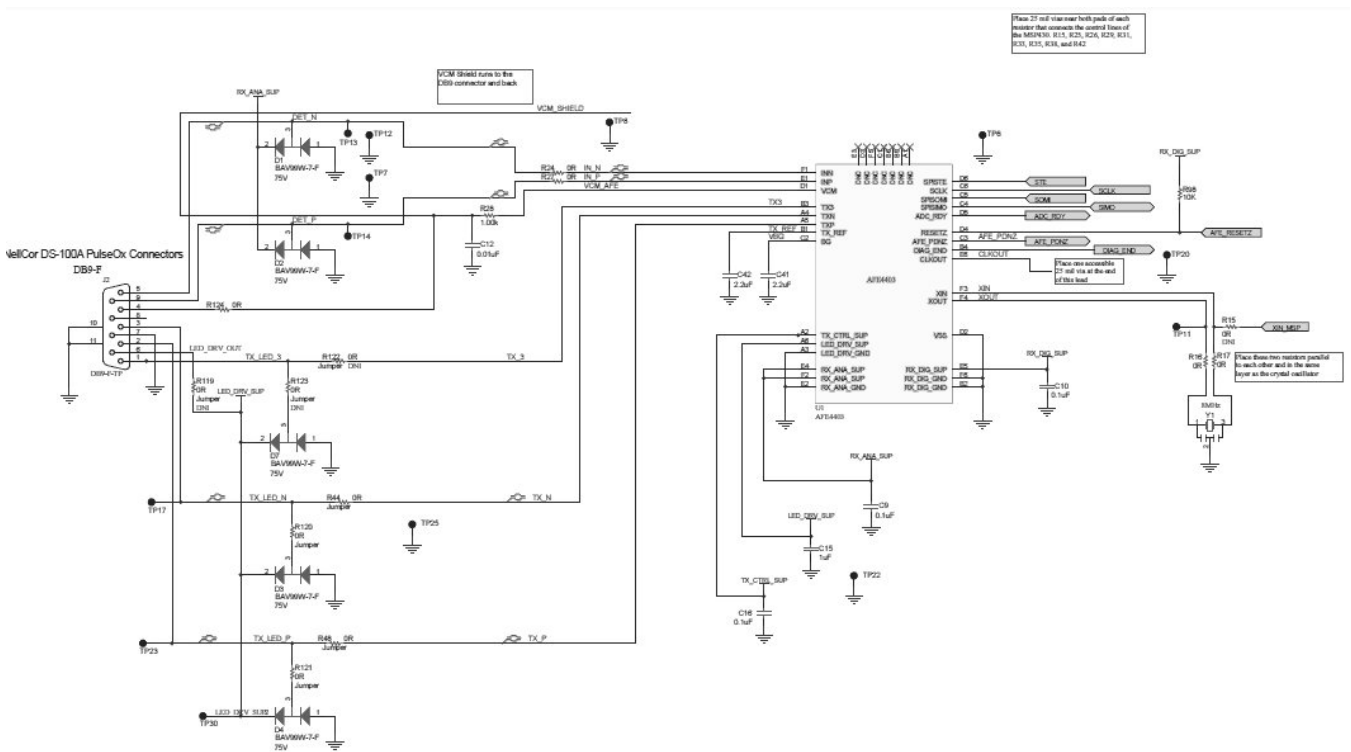

Figure 126. Schematic

9.2.1 Design Requirements

An SPO2 application usually involves a Red LED and IR LED. In addition, a heart rate monitoring application can use a different wavelength LED, such as a Green LED. The LEDs can be connected either in the common anode configuration or H-bridge configuration to the TXP, TXN pins. The LED connected to the TX3 pin can only be connected in the common anode configuration.

Typical Application (continued)

9.2.2 Detailed Design Procedure

Refer to [LED Configurations](#) for different ways to connect the LEDs to the TXP, TXN, and TX3 pins. The photodiode (shown in [Figure 127](#)) receives light from both the Red and IR phases and usually has good sensitivities at both these wavelengths.



Figure 127. Photodiode

The photodiode connected as shown in [Figure 127](#) operates in zero bias because of the negative feedback from the transimpedance amplifier. The signal current generated by the photodiode is converted into a voltage by the transimpedance amplifier, which has a programmable transimpedance gain. The rest of the signal chain then presents a voltage to the ADC. The full-scale output of the transimpedance amplifier is ± 1 V and the full-scale input to the ADC is ± 1.2 V. An automatic gain control (AGC) loop can be used to set the target dc voltage at the ADC input to approximately 50% of its full-scale. Such an AGC loop can control a combination of the LED current and TIA gain to achieve this target value.

9.2.3 Application Curves

This section outlines the trends seen in the [Typical Characteristics](#) curves from an application perspective.

[Figure 5](#) illustrates the receiver currents in external clock mode with CLKOUT tri-stated. The curve in [Figure 5](#) are taken without the dynamic power-down feature enabled, so much lower currents can be achieved using the dynamic power-down feature. Enabling the crystal mode or removing the CLKOUT tri-state increases the receiver currents from the values depicted in the curve.

[Figure 6](#) illustrates the transmitter currents with a zero LED current setting. The average LED current can be computed based on the value of the PRF and LED pulse durations, and can be added to the LED_DRV_SUP current described in [Figure 6](#).

[Figure 7](#) illustrates the total receiver current (analog plus digital supply) for different clock divider ratios. For each clock divider ratio, the external clock frequency is swept in frequency such that the divided clock changes between 3 MHz to 7 MHz. Note however that the supported range for the divided clock is 4 MHz to 6 MHz at each division ratio. Also, the external clock should be limited to be between 4 MHz to 60 MHz.

[Figure 8](#) illustrates the power savings arising out of the dynamic power-down mode. This mode can be set by defining the start and end points for the signal PDN_CYCLE within the pulse repetition period. In [Figure 8](#), the LED pulse durations are chosen to be 100 μ s and the conversions are also chosen to be 100 μ s wide. Thus, the entire active period fits in 500 μ s. With the timing margins for t_1 and t_2 indicated in [Figure 67](#), the PDN_CYCLE pulse spans the rest of the pulse repetition period. As PRF reduces, the duty cycle of the PDN_CYCLE pulse (as a fraction of the pulse repetition period) increases, which is the reason for the power reduction at lower PRFs as seen in [Figure 8](#).

[Figure 9](#) illustrates the power savings as a function of the PDN_CYCLE duration at a fixed PRF of 100 Hz. A 100-Hz PRF corresponds to a period of 10 ms. [Figure 9](#) indicates the PDN_CYCLE duration swept from 0 ms to 9 ms. With higher durations of PDN_CYCLE, the receiver power reduces.

[Figure 10](#) illustrates the baseband response of the switched RC filter for a 5% and 25% duty cycle. When the duty cycle reduces, the effective bandwidth of the filter reduces.

Typical Application (continued)

Figure 128 shows the SNR of the signal chain as a function of the output voltage level. The data are taken by looping back the transmitter outputs to the receiver inputs using an external op amp that converts the transmitter voltage to a receiver input current. The loopback op amp and external resistors are an extra source of noise in this measurement, so the actual noise levels are higher than the total noise of the transmitter plus the receiver. The SNR in this curve (and other curves) is expressed in terms of dBFS, where the full-scale of the channel is used as the reference level. Because the valid operating range of the signal chain is ± 1 V, a full-scale of 2 V is used for converting the output noise to a dBFS number. %FS refers to the percentage of the output level as a function of the positive full-scale. For example, a 50 %FS curve corresponds to the case where the output level is 0.5 V. Also, the total noise in this curve is the total integrated noise in the digital output. All noise is contained in the Nyquist band, which extends from $-PRF / 2$ to $PRF / 2$.

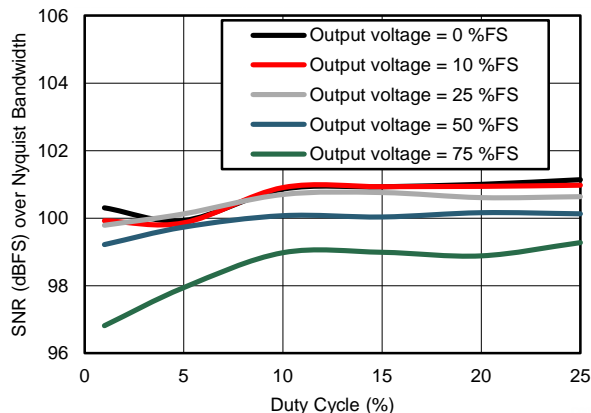

Figure 128. SNR over Nyquist Bandwidth vs Duty Cycle (Input Current with Tx-Rx Loopback)

Figure 129 is a representation of the same data as Figure 10. However, the noise is represented in terms of the input-referred noise current in pArms. By multiplying this number with the TIA gain setting (500 k in this case), the output noise voltage can be computed.

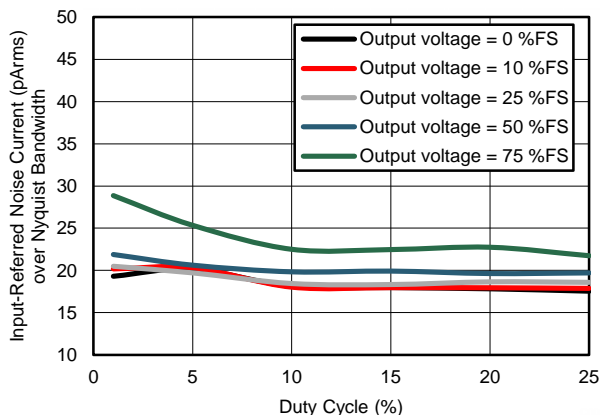

Figure 129. Input-Referred Noise Current over Nyquist Bandwidth vs Duty Cycle (Input Current with Tx-Rx Loopback)

Figure 13 illustrates the SNR from the receiver as a function of the sampling duty cycle (which is the sampling pulse duration referred to the pulse repetition period) for different settings of TIA gain. This curve is taken at 100-Hz PRF. The maximum duty cycle is limited to 25%. A lower sampling duty cycle also means a lower LED pulse duration duty cycle, which results in power saving.

Typical Application (continued)

Figure 14 illustrates the input-referred noise corresponding to Figure 13. Figure 15 and Figure 16 illustrate the SNR and input-referred noise current in a 0.1-Hz to 20-Hz band for the LED-ambient data. By performing a digital ambient subtraction, the low-frequency noise in the signal chain can be significantly attenuated. The noise levels in the bandwidth of interest are lower than the noise over the full Nyquist bandwidth. For a PPG signal, the signal band of interest is usually less than 10 Hz. By performing some digital low-pass filtering in the processor, this noise reduction can be achieved. Figure 17 and Figure 18 illustrate the noise reduction from ADC averaging. TI therefore recommends setting the number of ADC averages to the maximum allowed at a given PRF. Figure 19 and Figure 20 illustrate the noise at different PRFs over a 20-Hz bandwidth. At a higher PRF, the 20-Hz noise band is a smaller fraction of the Nyquist band. Thus, noise is lower at higher PRFs in these figures. Figure 21 and Figure 22 illustrate the noise at different PRFs over a 20-Hz bandwidth with dynamic power-down mode enabled. The active window remains as 500 μ s and all samples and conversions are performed at this time. For the rest of the period, the device is in dynamic power-down with the t_1 and t_2 values as described in Figure 67. Again, the noise reduces with higher PRF. Figure 23 and Figure 24 illustrate the noise as a function of the PDN_CYCLE duration varied from 0 ms to 9 ms, with the active duration (available for conversion) occupying the rest of the period. With higher PDN_CYCLE durations, the number of allowed ADC averages reduces, which explains the slight increase in noise at higher PDN_CYCLE durations. Figure 25 and Figure 26 illustrate the noise as a function of temperature over a 20-Hz bandwidth. The measurements are performed with a transmit-receive loopback as explained earlier. The input current is maintained at 1 μ A. Thus, for 250-k gain setting, the output voltage is 0.5 V and for a 500-k gain setting, the output voltage is 1 V. Figure 27 and Figure 28 illustrate the noise reduction using additional gain in stage 2. Figure 29 shows the noise as a function of the internal (divided) clock frequency. The external clock is varied from 7 MHz to 14 MHz with a clock division ratio of 2. This range of external clock results in the internal clock varying from 3.5 MHz to 7 MHz. Out of this range, 4 MHz to 6 MHz is the allowed range for the internal (divided) clock at all clock division ratios. Figure 30 illustrates the deviation in the measured LED current with respect to the calculated current when the LED current code is swept from 0 to 255 in steps of 1.

Figure 31 and Figure 32 illustrate the transmitter+receiver noise (in external loopback mode) as a function of the TX_REF voltage setting. At lower TX_REF voltages, there is a slight increase in the transmitter noise. This increase is not very apparent from the curves because the transmitter noise is at a level much lower than the total noise. Figure 33 illustrates the transmitter current as a function of the current setting code. Figure 34 illustrates the spread of the transmitter current taken across a large number of devices for the same current setting. Figure 35 illustrates how the LED current changes linearly with the TX_REF voltage for a fixed code.

10 Power Supply Recommendations

The AFE4403 has two sets of supplies: the receiver supplies (RX_ANA_SUP, RX_DIG_SUP) and the transmitter supplies (TX_CTRL_SUP, LED_DRV_SUP). The receiver supplies can be between 2.0 V to 3.6 V, whereas the transmitter supplies can be between 3.0 V to 5.25 V. Another consideration that determines the minimum allowed value of the transmitter supplies is the forward voltage of the LEDs being driven. The current source and switches inside the AFE require voltage headroom that mandates the transmitter supply to be a few hundred millivolts higher than the LED forward voltage. TX_REF is the voltage that governs the generation of the LED current from the internal reference voltage. Choosing the lowest allowed TX_REF setting reduces the additional headroom required but results in higher transmitter noise. Other than for the highest-end clinical SPO2 applications, this extra noise resulting from a lower TX_REF setting can be acceptable.

Consider a design where the LEDs are meant to be used in common anode configuration with a current setting of 50 mA. Assume that the LED manufacturer mentions the highest forward voltage of the LEDs is 2.5 V at this current setting. Further, assume that the TX_REF voltage is set to 0.5 V. The voltage headroom required in this case is 1 V. Thus, the LED_DRV_SUP must be driven with a voltage level greater than or equal to 3.5 V (2.5 V plus 1 V).

LED_DRV_SUP and TX_CTRL_SUP are recommended to be tied together to the same supply (between 3.0 V to 5.25 V). The external supply (connected to the common anode of the two LEDs) must be high enough to account for the forward drop of the LEDs as well as the voltage headroom required by the current source and switches inside the AFE. In most cases, this voltage is expected to fall below 5.25 V; thus the external supply can be the same as LED_DRV_SUP. However, there may be cases (for instance when two LEDs are connected in series) where the voltage required on the external supply is higher than 5.25 V. Such a case must be handled with care to ensure that the voltage on the TXP and TXN pins remains less than 5.25 V and never exceeds the supply voltage of LED_DRV_SUP, TX_CTRL_SUP by more than 0.3 V.

Many scenarios of power management are possible.

Case 1: The LED forward voltage is such that a voltage of 3.3 V is acceptable on LED_DRV_SUP. In this case, a single 3.3-V supply can be used to drive all four pins (RX_ANA_SUP, RX_DIG_SUP, TX_CTRL_SUP, LED_DRV_SUP). Care should be taken to provide some isolation between the transmit and receive supplies because LED_DRV_SUP carries the high-switching current from the LEDs.

Case 2: A low-voltage supply of 2.2 V is available in the system. In this case, a boost converter can be used to derive the voltage for LED_DRV_SUP, as shown in [Figure 130](#).

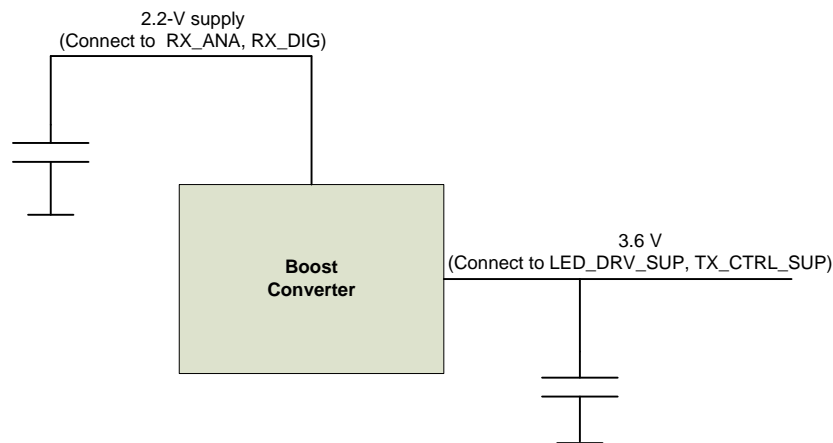

Figure 130. Boost Converter

The boost converter requires a clock (usually in the megahertz range) and there is usually a ripple at the boost converter output at this switching frequency. While this frequency is much higher than the signal frequency of interest (which is at maximum a few tens of hertz around dc), a small fraction of this switching noise can possibly alias to the low-frequency band. Therefore, TI strongly recommends that the switching frequency of the boost converter be offset from every multiple of the PRF by at least 20 Hz. This offset can be ensured by choosing the appropriate PRF.

Case 3: In cases where a high-voltage supply is available in the system, a buck converter or an LDO can be used to derive the voltage levels required to drive RX_ANA and RX_DIG, as shown in [Figure 131](#).

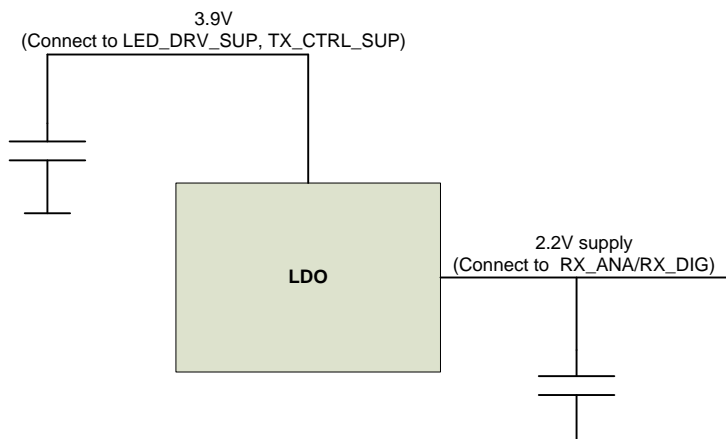

Figure 131. Buck Converter or an LDO

10.1 Power Consumption Considerations

The lowest power consumption mode of the AFE4403 corresponds to the following settings:

- PRF = 62.5 Hz,
- External clock mode (XTALDIS = 1), and
- CLKOUT tri-stated (CLKOUT_TRI = 1).

With the above settings, the currents taken from the supplies are as shown in [Table 9](#). The LED driver current is with zero LED current setting.

Table 9. Current Consumption in Normal Mode

SUPPLY	VOLTAGE (V)	CURRENT (µA)
RX_ANA	2	490
RX_DIG	2	155
TX_CTRL_SUP	3	15
LED_DRV_SUP	3	55

Enabling the crystal (XTALDIS = 0) leads to an additional power consumption that can be estimated to be approximately equal to $(2 \times C_{sh} + 0.5 \times C1 + 0.5 \times C2) \times 0.4 \times f_{XTAL}$, where C_{sh} is the effective shunt capacitance of the crystal, C1 and C2 are the capacitances from the XIN and XOUT pins to ground, and f_{XTAL} is the frequency of the crystal.

Removing the CLKOUT tri-state leads to an additional power consumption of approximately $C_{LOAD} \times V_{SUP} \times f$, where V_{SUP} is the supply voltage of RX_DIG in volts, $f = 4$ MHz, C_{LOAD} = the capacitive load on the CLKOUT pin + 2 pF.

The power consumption can be reduced significantly by using the dynamic power-down mode. An illustration of this mode is shown in [Table 10](#), where:

- PRF = 62.5 Hz,
- Dynamic power-down is active for 14.7 ms every pulse repetition period,
- All four bits (DYNAMIC[4:1]) are set to 1,
- External clock mode (XTALDIS = 1), and
- CLKOUT is tri-stated (CLKOUT_TRI = 1).

Table 10. Current Consumption in Dynamic Power-Down Mode

SUPPLY	VOLTAGE (V)	CURRENT (μA)
RX_ANA	2	150
RX_DIG	2	155
TX_CTRL_SUP	3	5
LED_DRV_SUP	3	5

11 Layout

11.1 Layout Guidelines

Some key layout guidelines are mentioned below:

1. TXP, TXN, and TX3 are fast-switching lines and should be routed away from sensitive reference lines as well as from the INP, INN inputs.
2. If the INP, INN lines are required to be routed over a long trace, TI recommends that VCM be used as a shield for the INP, INN lines.
3. The device can draw high-switching currents from the LED_DRV_SUP pin. Therefore, TI recommends having a decoupling capacitor electrically close to the pin.

11.2 Layout Example

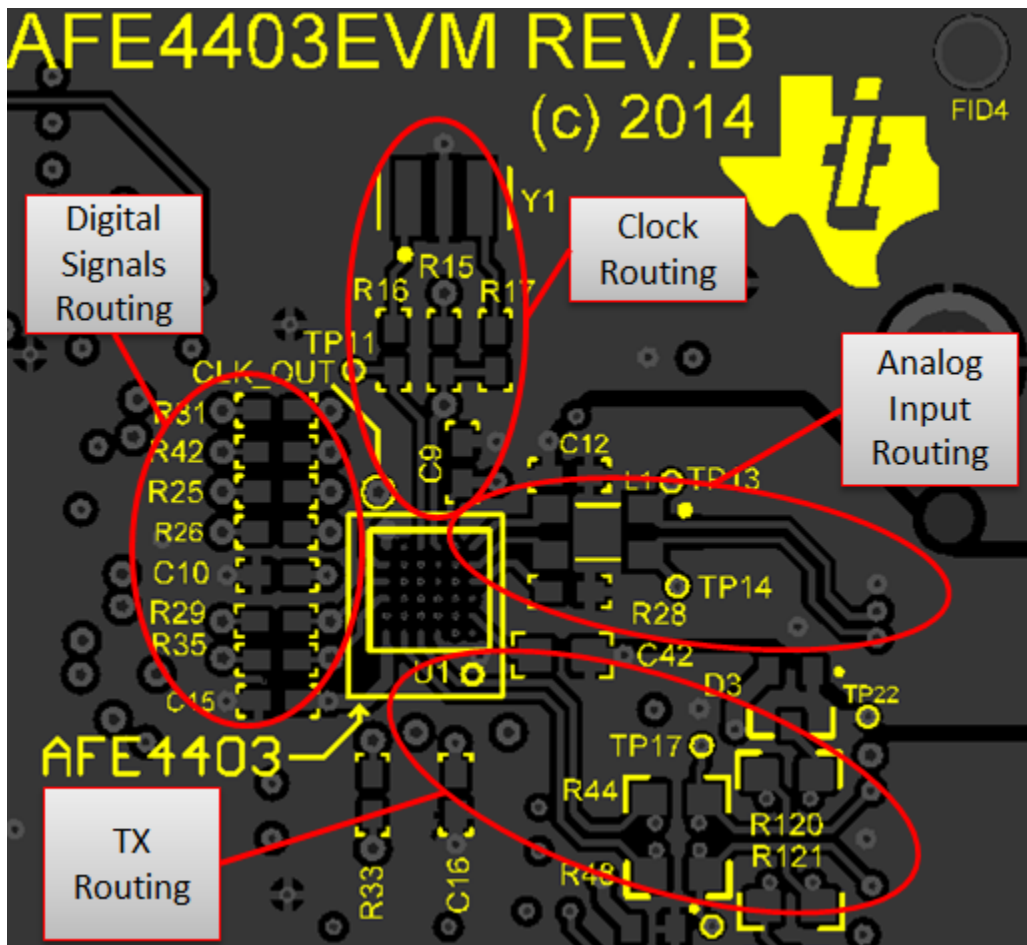

Figure 132. Example Layout

12 Device and Documentation Support

12.1 Trademarks

SPI is a trademark of Motorola.

All other trademarks are the property of their respective owners.

12.2 Electrostatic Discharge Caution



This integrated circuit can be damaged by ESD. Texas Instruments recommends that all integrated circuits be handled with appropriate precautions. Failure to observe proper handling and installation procedures can cause damage.

ESD damage can range from subtle performance degradation to complete device failure. Precision integrated circuits may be more susceptible to damage because very small parametric changes could cause the device not to meet its published specifications.

12.3 Glossary

[SLYZ022](#) — *TI Glossary*.

This glossary lists and explains terms, acronyms, and definitions.

13 Mechanical, Packaging, and Orderable Information

The following pages include mechanical, packaging, and orderable information. This information is the most current data available for the designated devices. This data is subject to change without notice and revision of this document. For browser-based versions of this data sheet, refer to the left-hand navigation.

PACKAGING INFORMATION

Orderable Device	Status (1)	Package Type	Package Drawing	Pins	Package Qty	Eco Plan (2)	Lead/Ball Finish (6)	MSL Peak Temp (3)	Op Temp (°C)	Device Marking (4/5)	Samples
AFE4403YZPR	ACTIVE	DSBGA	YZP	36	3000	Green (RoHS & no Sb/Br)	SNAGCU	Level-1-260C-UNLIM	-20 to 70	AFE4403	Samples
AFE4403YZPT	ACTIVE	DSBGA	YZP	36	250	Green (RoHS & no Sb/Br)	SNAGCU	Level-1-260C-UNLIM	-20 to 70	AFE4403	Samples

(1) The marketing status values are defined as follows:

ACTIVE: Product device recommended for new designs.

LIFEBUY: TI has announced that the device will be discontinued, and a lifetime-buy period is in effect.

NRND: Not recommended for new designs. Device is in production to support existing customers, but TI does not recommend using this part in a new design.

PREVIEW: Device has been announced but is not in production. Samples may or may not be available.

OBSELETE: TI has discontinued the production of the device.

(2) Eco Plan - The planned eco-friendly classification: Pb-Free (RoHS), Pb-Free (RoHS Exempt), or Green (RoHS & no Sb/Br) - please check <http://www.ti.com/productcontent> for the latest availability information and additional product content details.

TBD: The Pb-Free/Green conversion plan has not been defined.

Pb-Free (RoHS): TI's terms "Lead-Free" or "Pb-Free" mean semiconductor products that are compatible with the current RoHS requirements for all 6 substances, including the requirement that lead not exceed 0.1% by weight in homogeneous materials. Where designed to be soldered at high temperatures, TI Pb-Free products are suitable for use in specified lead-free processes.

Pb-Free (RoHS Exempt): This component has a RoHS exemption for either 1) lead-based flip-chip solder bumps used between the die and package, or 2) lead-based die adhesive used between the die and leadframe. The component is otherwise considered Pb-Free (RoHS compatible) as defined above.

Green (RoHS & no Sb/Br): TI defines "Green" to mean Pb-Free (RoHS compatible), and free of Bromine (Br) and Antimony (Sb) based flame retardants (Br or Sb do not exceed 0.1% by weight in homogeneous material)

(3) MSL, Peak Temp. - The Moisture Sensitivity Level rating according to the JEDEC industry standard classifications, and peak solder temperature.

(4) There may be additional marking, which relates to the logo, the lot trace code information, or the environmental category on the device.

(5) Multiple Device Markings will be inside parentheses. Only one Device Marking contained in parentheses and separated by a "~" will appear on a device. If a line is indented then it is a continuation of the previous line and the two combined represent the entire Device Marking for that device.

(6) Lead/Ball Finish - Orderable Devices may have multiple material finish options. Finish options are separated by a vertical ruled line. Lead/Ball Finish values may wrap to two lines if the finish value exceeds the maximum column width.

Important Information and Disclaimer:The information provided on this page represents TI's knowledge and belief as of the date that it is provided. TI bases its knowledge and belief on information provided by third parties, and makes no representation or warranty as to the accuracy of such information. Efforts are underway to better integrate information from third parties. TI has taken and continues to take reasonable steps to provide representative and accurate information but may not have conducted destructive testing or chemical analysis on incoming materials and chemicals. TI and TI suppliers consider certain information to be proprietary, and thus CAS numbers and other limited information may not be available for release.

In no event shall TI's liability arising out of such information exceed the total purchase price of the TI part(s) at issue in this document sold by TI to Customer on an annual basis.

TAPE AND REEL INFORMATION

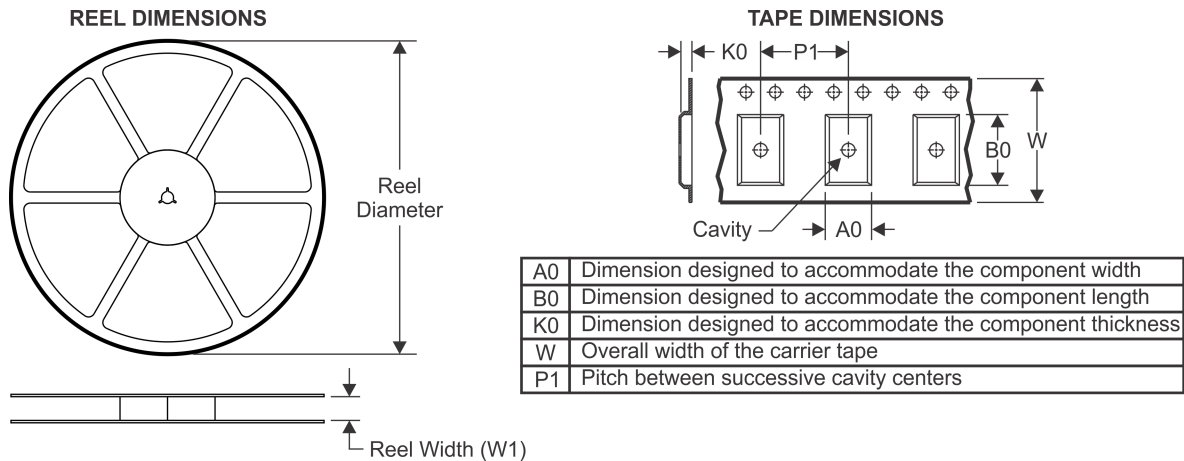

QUADRANT ASSIGNMENTS FOR PIN 1 ORIENTATION IN TAPE

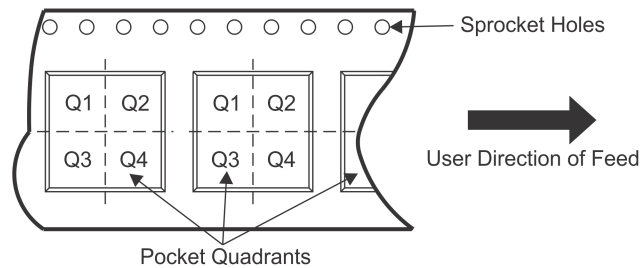

*All dimensions are nominal

Device	Package Type	Package Drawing	Pins	SPQ	Reel Diameter (mm)	Reel Width W1 (mm)	A0 (mm)	B0 (mm)	K0 (mm)	P1 (mm)	W (mm)	Pin1 Quadrant
AFE4403YZPR	DSBGA	YZP	36	3000	180.0	8.4	3.16	3.16	0.71	4.0	8.0	Q1
AFE4403YZPT	DSBGA	YZP	36	250	180.0	8.4	3.16	3.16	0.71	4.0	8.0	Q1

TAPE AND REEL BOX DIMENSIONS

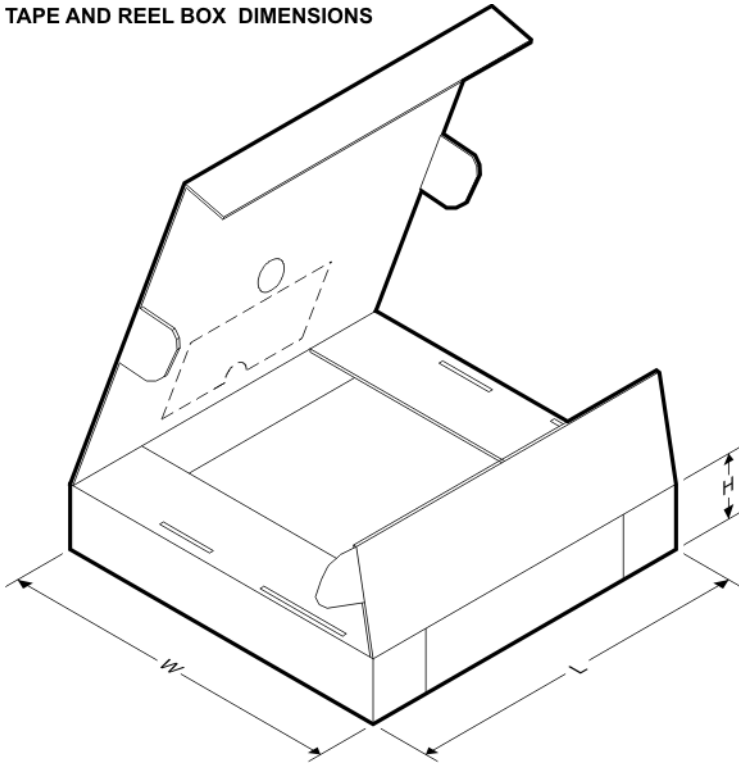

*All dimensions are nominal

Device	Package Type	Package Drawing	Pins	SPQ	Length (mm)	Width (mm)	Height (mm)
AFE4403YZPR	DSBGA	YZP	36	3000	182.0	182.0	20.0
AFE4403YZPT	DSBGA	YZP	36	250	182.0	182.0	20.0

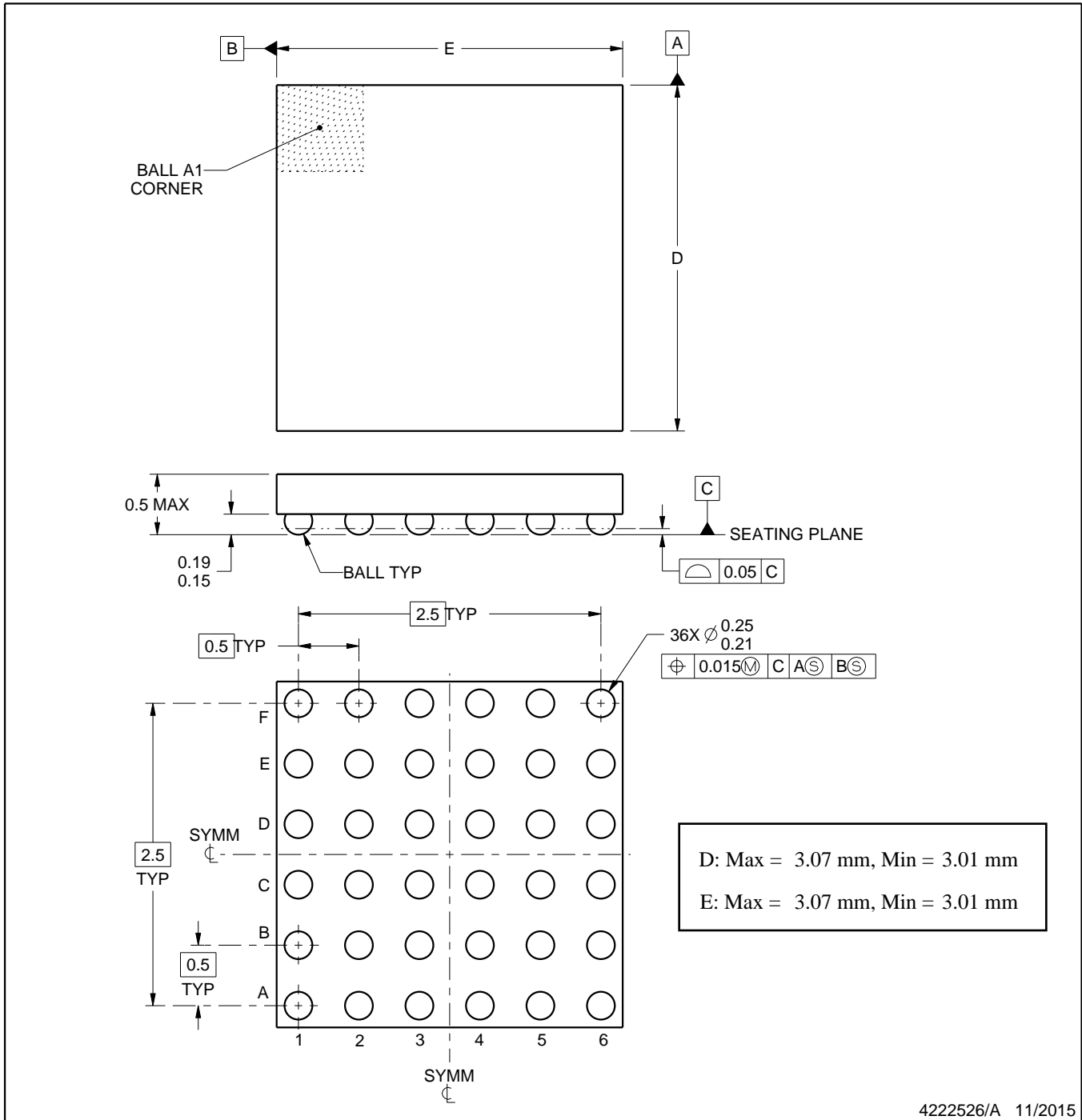
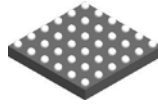

NOTES:

NanoFree is a trademark of Texas Instruments.

1. All linear dimensions are in millimeters. Any dimensions in parenthesis are for reference only. Dimensioning and tolerancing per ASME Y14.5M.
2. This drawing is subject to change without notice.
3. NanoFree™ package configuration.

EXAMPLE BOARD LAYOUT

YZP0036

DSBGA - 0.5 mm max height

DIE SIZE BALL GRID ARRAY

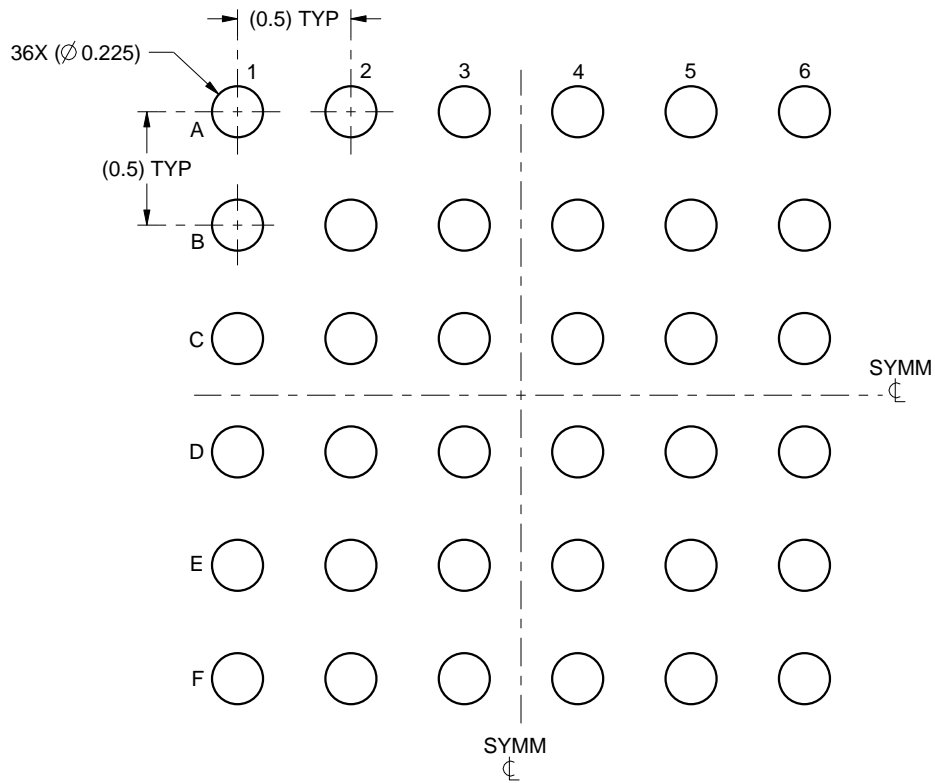

LAND PATTERN EXAMPLE
SCALE:30X

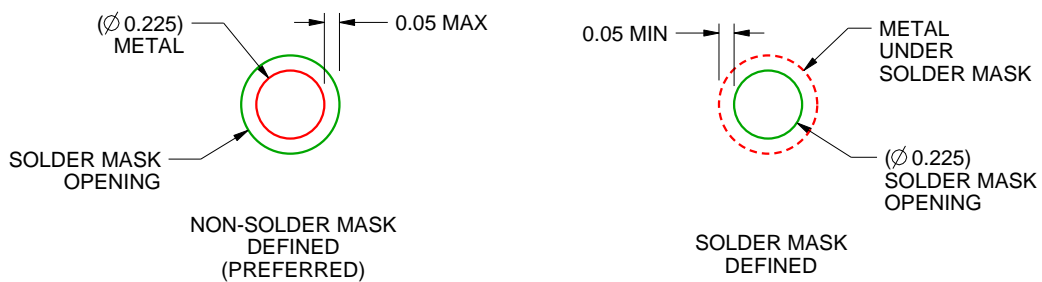

SOLDER MASK DETAILS
NOT TO SCALE

4222526/A 11/2015

NOTES: (continued)

- Final dimensions may vary due to manufacturing tolerance considerations and also routing constraints. For more information, see Texas Instruments literature number SNVA009 (www.ti.com/lit/snva009).

EXAMPLE STENCIL DESIGN

YZP0036

DSBGA - 0.5 mm max height

DIE SIZE BALL GRID ARRAY

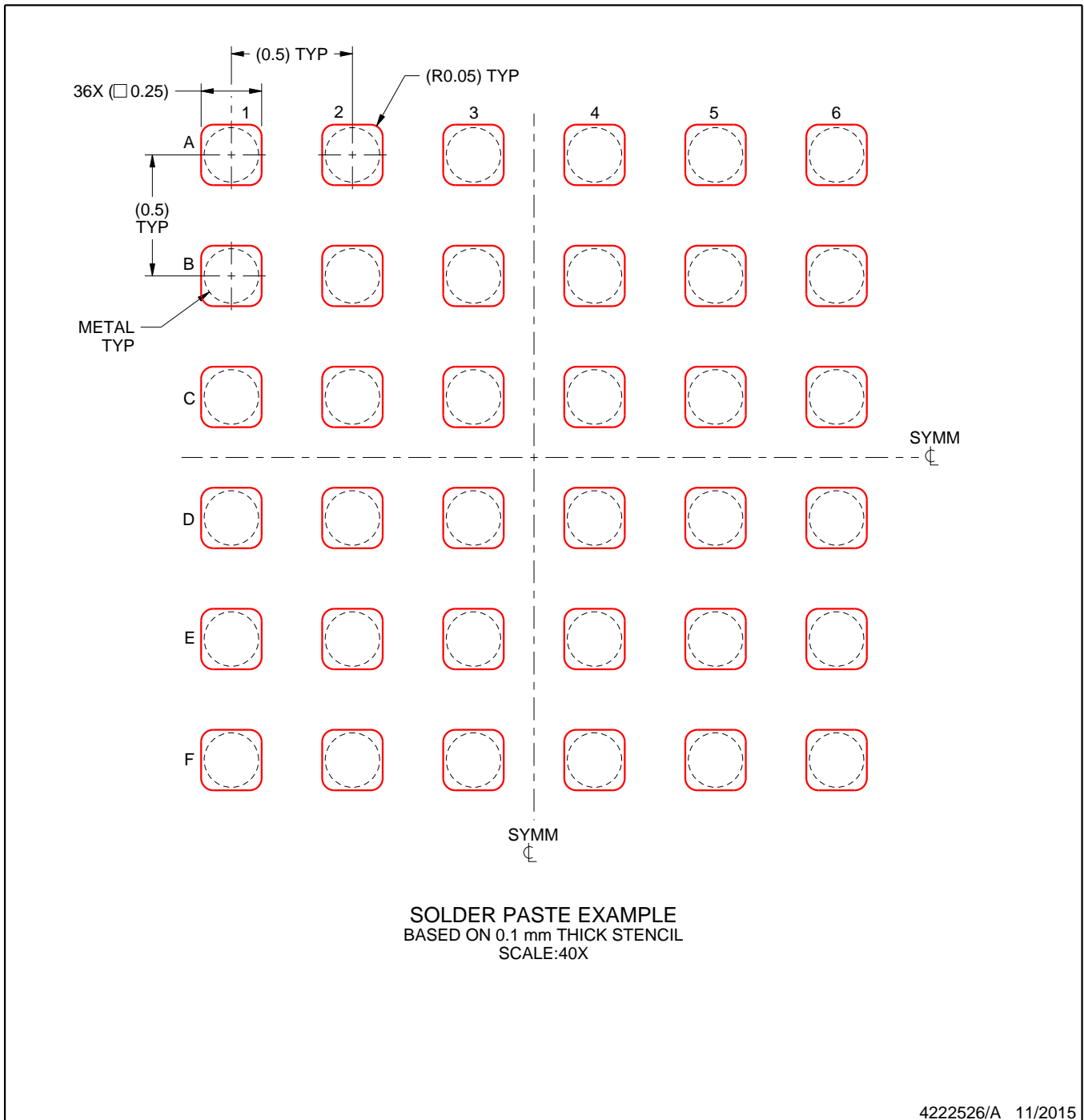

NOTES: (continued)

5. Laser cutting apertures with trapezoidal walls and rounded corners may offer better paste release.

IMPORTANT NOTICE AND DISCLAIMER

TI PROVIDES TECHNICAL AND RELIABILITY DATA (INCLUDING DATASHEETS), DESIGN RESOURCES (INCLUDING REFERENCE DESIGNS), APPLICATION OR OTHER DESIGN ADVICE, WEB TOOLS, SAFETY INFORMATION, AND OTHER RESOURCES "AS IS" AND WITH ALL FAULTS, AND DISCLAIMS ALL WARRANTIES, EXPRESS AND IMPLIED, INCLUDING WITHOUT LIMITATION ANY IMPLIED WARRANTIES OF MERCHANTABILITY, FITNESS FOR A PARTICULAR PURPOSE OR NON-INFRINGEMENT OF THIRD PARTY INTELLECTUAL PROPERTY RIGHTS.

These resources are intended for skilled developers designing with TI products. You are solely responsible for (1) selecting the appropriate TI products for your application, (2) designing, validating and testing your application, and (3) ensuring your application meets applicable standards, and any other safety, security, or other requirements. These resources are subject to change without notice. TI grants you permission to use these resources only for development of an application that uses the TI products described in the resource. Other reproduction and display of these resources is prohibited. No license is granted to any other TI intellectual property right or to any third party intellectual property right. TI disclaims responsibility for, and you will fully indemnify TI and its representatives against, any claims, damages, costs, losses, and liabilities arising out of your use of these resources.

TI's products are provided subject to TI's Terms of Sale (www.ti.com/legal/termsofsale.html) or other applicable terms available either on ti.com or provided in conjunction with such TI products. TI's provision of these resources does not expand or otherwise alter TI's applicable warranties or warranty disclaimers for TI products.

Mailing Address: Texas Instruments, Post Office Box 655303, Dallas, Texas 75265
Copyright © 2019, Texas Instruments Incorporated

Looking for pricing, stock, or lifecycle information?

Click below to explore more details on WIN SOURCE:

 [View AFE4403YZPT on WIN SOURCE](#)

 [Texas Instruments](#) Information

Optimize Your Supply Chain with WIN SOURCE Solutions

-  Global Sourcing Solution
-  Obsolete Management
-  Cost Control Management
-  Shortage Management
-  Alternative Solution
-  Excess Inventory Management