



**THE DATASHEET OF  
EVAL-ADM3095EEBZ**



## Certified Evaluation Board for the **ADM3095E** Level 4 EMC Protected RS-485 Transceiver with Full $\pm 42$ V Fault Protection

### FEATURES

- Level 4 IEC EMC certified RS-485 evaluation board
- Certified RS-485 A and B bus pin protection, passing
  - IEC 61000-4-5 surge protection to  $\pm 4$  kV
  - IEC 61000-4-4 EFT protection to  $\pm 2$  kV
  - IEC 61000-4-2 ESD protection to
    - $\pm 8$  kV contact discharge
    - $\pm 15$  kV air gap discharge
- Certified IEC 61000-4-6 conducted RF immunity to Level 3 testing (10 V/m rms)
- Passes RS-485 A and B bus pins HBM ESD to  $> \pm 30$  kV
- Provides A and B bus pin fault protection to  $\pm 42$  V ac/dc peak
- Convenient connections for power supplies and signals through screw terminal blocks
- 1.62 V to 5.5 V operating voltage range on  $V_{IO}$  logic supply
- 3.0 V to 5.5 V operating voltage range on  $V_{CC}$
- Easily configurable through jumper connections
- Test points for measuring all signals

### EVALUATION KIT CONTENTS

[EVAL-ADM3095EEBZ](#)

### GENERAL DESCRIPTION

The [EVAL-ADM3095EEBZ](#) can be used for easy evaluation of the [ADM3095E](#) RS-485 transceiver with Level 4 IEC electromagnetic compatibility (EMC) and full  $\pm 42$  V supply fault protection. Screw terminal blocks provide convenient connections for the power and signal connections.

The [EVAL-ADM3095EEBZ](#) is easily configured through jumper connections. Jumper connections can enable or disable the RS-485 driver and receiver. Two power supplies, one supply for the  $V_{IO}$  logic supply and one  $V_{CC}$  supply for the RS-485 driver/receiver, can power the [EVAL-ADM3095EEBZ](#). When powering with only one power supply, the [ADM3095E](#)  $V_{IO}$  and  $V_{CC}$  pins can connect with a convenient on-board jumper. In addition, test points are included for all power and signal lines.

### CERTIFIED IEC EMC RS-485 EVALUATION BOARD

The [EVAL-ADM3095EEBZ](#) was lab tested and certified to provide IEC 61000-4-5 surge protection to  $\pm 4$  kV, IEC 61000-4-4 electrical fast transient (EFT) protection to  $\pm 2$  kV, and IEC 61000-4-2 electrostatic discharge (ESD) protection to  $\pm 8$  kV (contact discharge) and  $\pm 15$  kV (air gap discharge). The [EVAL-ADM3095EEBZ](#) was tested and confirmed to provide  $> \pm 30$  kV human body model (HBM) ESD protection on RS-485 A and B bus pins to GND. The [EVAL-ADM3095EEBZ](#) can withstand high voltage faults up to  $\pm 42$  V ac/dc peak on the RS-485 A and B bus pins.

For full details on the [ADM3095E](#), see the [ADM3095E](#) data sheet, which should be consulted in conjunction with this user guide when using these evaluation boards.

### EVAL-ADM3095EEBZ PHOTOGRAPH

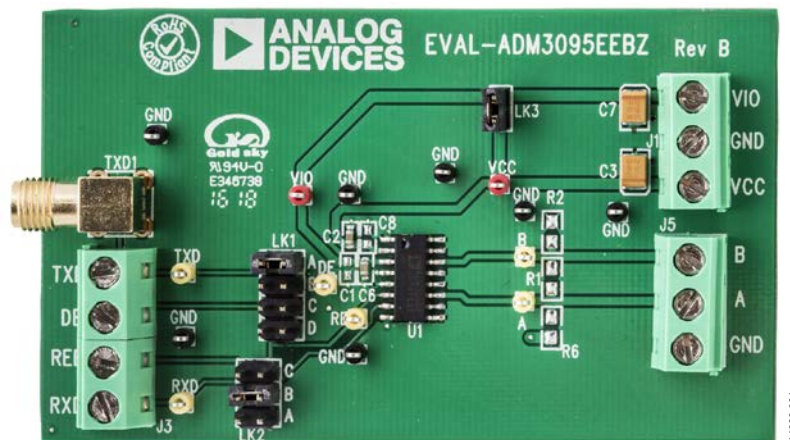

Figure 1.

**TABLE OF CONTENTS**

|   |   |  |    |
|---|---|--|----|
| Features .....                                    | 1 | IEC EMC Robust RS-485 Evaluation Board.....      | 4  |
| Evaluation Kit Contents.....                      | 1 | IEC 61000-4-2 ESD Protection .....               | 4  |
| General Description .....                         | 1 | IEC 61000-4-4 EFT Protection .....               | 5  |
| Certified IEC EMC RS-485 Evaluation Board.....    | 1 | IEC 61000-4-5 Surge Protection .....             | 6  |
| EVAL-ADM3095EEBZ Photograph .....                 | 1 | IEC 61000-4-6 Conducted RF Immunity Testing..... | 7  |
| Revision History .....                            | 2 | ±42 V Miswire Protection .....                   | 8  |
| Evaluation Board Hardware Configuration .....     | 3 | Evaluation Board Schematic .....                 | 9  |
| Test Setup .....                                  | 3 | Assembly Drawings and Board Layout .....         | 10 |
| Jumper Settings.....                              | 3 | Ordering Information.....                        | 11 |
| Termination and Pull-Up/Pull-Down Resistors ..... | 4 | Bill of Materials.....                           | 11 |
| Decoupling and Reservoir Capacitors .....         | 4 |  |    |

**REVISION HISTORY**

**3/2017—Revision 0: Initial Version**

## EVALUATION BOARD HARDWARE CONFIGURATION

### TEST SETUP

The EVAL-ADM3095EEBZ is shown in Figure 2 with the default jumper settings on LK1 and LK2 (driver and receiver enabled), power connections on J1, input signal connection on J3, and probes attached to Rx, Tx, A, and B for a loopback test.

### JUMPER SETTINGS

Use jumpers on the EVAL-ADM3095EEBZ evaluation board to configure the inputs to the ADM3095E (see Table 1). Do not place multiple jumper blocks on LK1 and LK2 because the input sources can short together. For each link, a single jumper block can move from one position to another, as specified in Table 1.

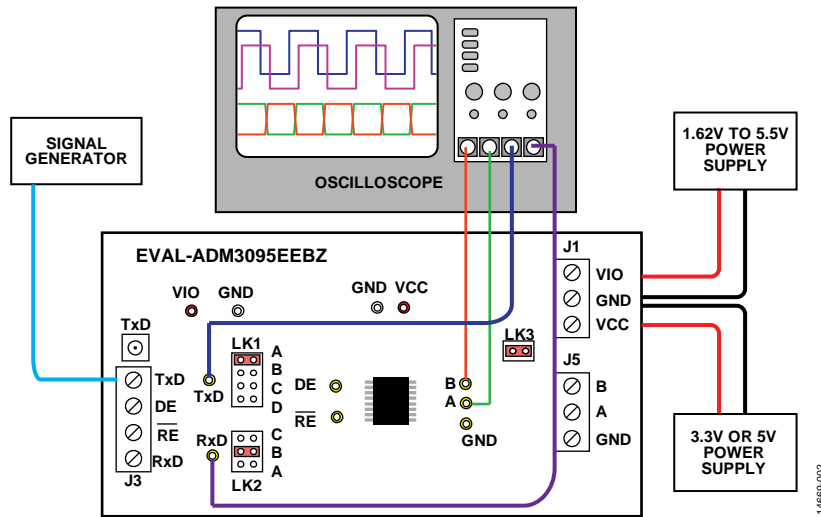

Figure 2. Basic Operation of the Evaluation Board for the ADM3095E Level 4 EMC and ±4 V peak AC/DC Supply Fault Protected RS-485 Transceiver

Table 1. Jumper Configuration

| Link | Connection    | Description  |
|------|---------------|--|
| LK1  | A             | Connects the driver enable input (DE) of the ADM3095E to V <sub>CC</sub> . This setting enables the driver.  |
|      | B             | Connects the driver enable input (DE) of the ADM3095E to GND. This setting disables the driver.  |
|      | C             | Connects the driver enable input (DE) of the ADM3095E to the J3-2 terminal block connector.  |
|      | D             | Connects the driver enable input (DE) of the ADM3095E to the receiver enable input ( $\overline{\text{RE}}$ ); that is, the input for both $\overline{\text{RE}}$ and DE is set by LK1. This setting ensures that when the driver is enabled, the receiver is disabled, or when the driver is disabled, the receiver is enabled. |
| LK2  | A             | Connects the receiver enable input ( $\overline{\text{RE}}$ ) of the ADM3095E to V <sub>CC</sub> . This setting disables the receiver.   |
|      | B             | Connects the receiver enable input ( $\overline{\text{RE}}$ ) of the ADM3095E to GND. This setting enables the receiver.   |
|      | C             | Connects the receiver enable input ( $\overline{\text{RE}}$ ) of the ADM3095E to the J3-3 terminal block connector.  |
| LK3  | Connected     | Connects the VIO trace to the VCC trace. The EVAL-ADM3095EEBZ can be powered from one power supply only.   |
|      | Not connected | The VIO and VCC traces are not connected. The user must power the EVAL-ADM3095EEBZ from two power supplies: one for the VIO and one for the VCC.   |

**TERMINATION AND PULL-UP/PULL-DOWN RESISTORS**

The EVAL-ADM3095EEBZ includes the R1 footprint for fitting a termination resistor between the A and B driver outputs and receiver inputs. By default, the 120 Ω resistor (R1) between Pin A and Pin B, shown in Figure 7, is not on the EVAL-ADM3095EEBZ. Remove this resistor if the EVAL-ADM3095EEBZ connects to a bus that already terminates at both ends. For more information about proper termination, see the AN-960 Application Note, RS-485/RS-422 Circuit Implementation Guide.

Although the ADM3095E has a built-in receiver fail-safe for the bus idle condition, there are footprints on the EVAL-ADM3095EEBZ for fitting the R6 pull-up resistor to VCC on Pin A, as well as the R2 pull-down resistor to GND on Pin B. When connecting to other devices that require such external biasing resistors on the bus, these resistors can be fitted. The exact value required for a 200 mV minimum differential voltage in the bus idle condition depends on the VCC supply voltage (for example, 960 Ω for 3.3 V and 1440 Ω for 5 V).

For more information about the bus idle fail-safe, see the AN-960 Application Note, RS-485/RS-422 Circuit Implementation Guide.

**DECOUPLING AND RESERVOIR CAPACITORS**

The EVAL-ADM3095EEBZ uses the following decoupling and reservoir capacitors:

- C2 and C6 are 100 nF ceramic capacitors fitted between VCC (Pin 2) and GND (Pin 1), and VIO (Pin 3) and GND (Pin 1), respectively. Pads for additional capacitors (C1 and C8) are unpopulated at the printed circuit board (PCB) build.
- Additional 10 μF tantalum capacitors (C3 and C7) are added for the power supply inputs at the J1 connector.

**IEC EMC ROBUST RS-485 EVALUATION BOARD**

The EVAL-ADM3095EEBZ was lab tested and certified to provide RS-485 A and B bus pin protection for the following IEC system level standards and test levels:

- Protection against IEC 61000-4-5 surge protection to ±4 kV
- Protection against IEC 61000-4-4 EFT protection to ±2 kV
- Protection against IEC 61000-4-2 ESD protection to ±8 kV for contact discharge and ±15 kV for air gap discharge
- IEC 61000-4-6 conducted radio frequency (RF) immunity to Level 3 (10 V/m rms)

The EVAL-ADM3095EEBZ evaluation board has been lab tested and confirmed to pass HBM ESD to >±30 kV on the RS-485 A and B bus pins.

The EVAL-ADM3095EEBZ evaluation board can withstand high voltage faults to ±42 V ac/dc peak on RS-485 A and B bus pins.

**IEC 61000-4-2 ESD PROTECTION**

The IEC 61000-4-2 ESD protection standard describes testing using two coupling methods: contact discharge and air gap discharge. Contact discharge implies a direct contact between the discharge gun and the unit under test. During air gap discharge testing, the charged electrode of the discharge gun moves toward the unit under test until a discharge occurs as an arc across the air gap. The discharge gun does not make direct contact with the unit under test.

The ADM3095E data sheet provides additional information on the IEC 61000-4-2 ESD protection standard, including test waveforms. Figure 3 shows an example test setup where the EVAL-ADM3095EEBZ PCB was tested to both contact and air gap discharge IEC 61000-4-2 ESD. Testing was performed in normal transceiver operation, with the ADM3095E clocking data at 2.0 Mbps, and with the IEC ESD gun connected to the local bus GND. In this configuration, Table 2 shows that the ADM3095E protects against IEC 61000-4-2 Level 4, and it also details the Class B compliance of the ADM3095E to the IEC 61000-4-2 ESD protection.

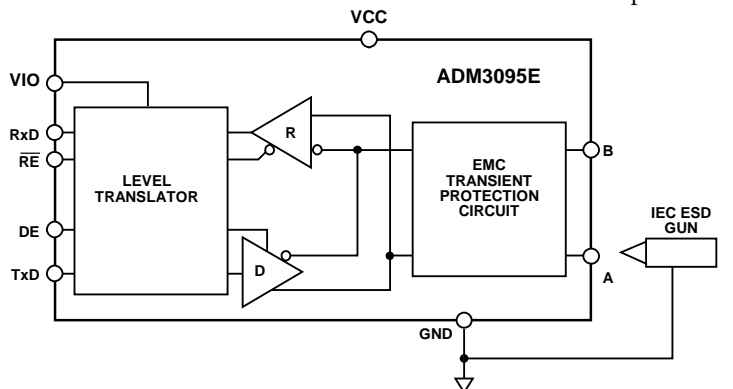

Figure 3. IEC 61000-4-2 ESD Testing to GND

Table 2. IEC 61000-4-2 Certified Test Results

| ESD Gun Connection Point | IEC 61000-4-2 Test Result                                | Certified Result        |
|--------------------------|--|-------------------------|
| GND                      | ±15 kV for air and ±8 kV for contact, Level 4 protection | Yes, Class B compliance |

**IEC 61000-4-4 EFT PROTECTION**

During IEC 61000-4-4 EFT testing, EFT fast burst transients are coupled onto RS-485 communication lines using a capacitive clamp, as described in Figure 4. The IEC EFT clamp edge is placed at 50 cm away from the equipment under test (EUT), EVAL-ADM3095EEBZ. The EFT generator is setup for both 5 kHz and 100 kHz repetitive EFT bursts. The ADM3095E data sheet provides additional information on the IEC 61000-4-4 EFT protection standard, including test waveforms. Testing is performed in normal transceiver operation, with the ADM3095E clocking data at 2.0 Mbps.

With the IEC EFT clamp connected to GND, the ADM3095E is robust to IEC EFT transients and protects against the highest level recognized in the standard (Level 4) which defines a voltage level of ±2 kV. Table 3 summarizes the IEC 61000-4-4 EFT certified test results, and it also details the Class B compliance of the ADM3095E to the IEC 61000-4-4 EFT protection.

For a shielded cable, these test results are valid for setups with or without an RS-485 cable shield connection to GND. The test results are also valid for using an unshielded twisted pair cable (with no shielded braid).

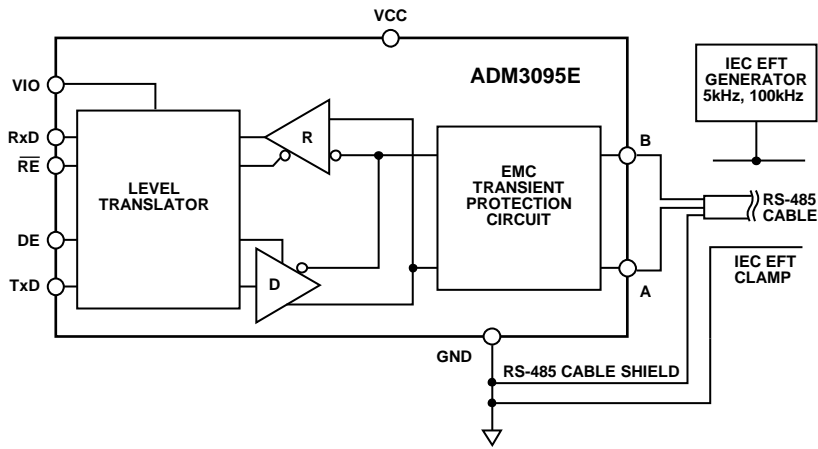

Figure 4. IEC 61000-4-4 EFT Testing to GND

Table 3. IEC 61000-4-4 Certified Test Results

| EFT Clamp Connection Point | IEC 61000-4-4 Test Result | Certified Result        |
|----------------------------|---------------------------|-------------------------|
| GND                        | ±2 kV Level 4 protection  | Yes, Class B compliance |

**IEC 61000-4-5 SURGE PROTECTION**

The IEC 61000-4-5 surge testing involves using a coupling network to couple the surge transient into the RS-485 A and B bus pins. The coupling network for a half-duplex RS-485 device consists of an 80 Ω resistor on both the A and B lines and a coupling device. The total parallel sum of the resistance is 40 Ω. The coupling device (CD) can be capacitors, gas arrestors, clamping devices, or any method that allows the EUT to function correctly during the applied test. During the surge test, five positive and five negative pulses are applied to the data ports with a maximum time interval of one minute between each pulse. Testing was

performed in normal transceiver operation with the ADM3095E clocking data at 2.0 Mbps. Figure 5 shows the test setup for surge testing. The ADM3095E data sheet provides additional information on the IEC 61000-4-5 surge protection, including test waveforms.

With the IEC surge generator connected to GND, the ADM3095E is robust to IEC 61000-4-5 events and protects against the highest level recognized in the standard (Level 4), which defines a peak voltage of ±4 kV. Table 4 summarizes the certified test results, and it also details the Class B compliance of the ADM3095E to the IEC 61000-4-5 surge protection when tested to GND.

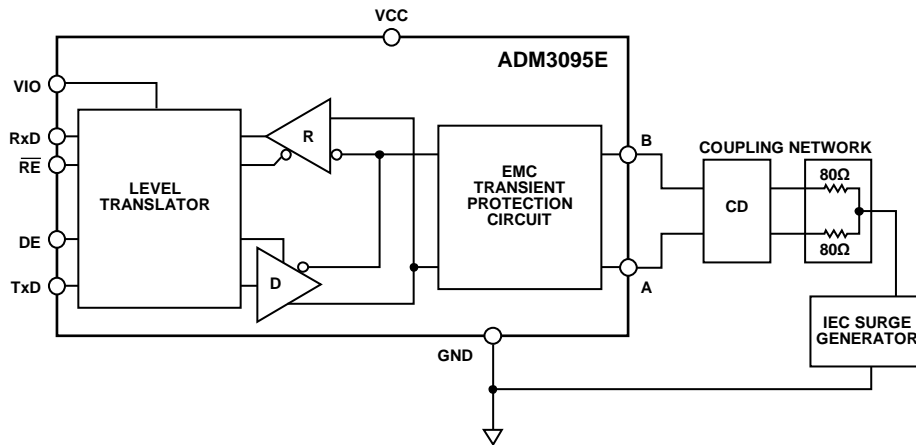

Figure 5. IEC 61000-4-5 Surge Testing to GND

**Table 4. IEC 61000-4-5 Certified Test Results**

| Surge Generator Connection Point | IEC 61000-4-5 Test Result | Certified Result        |
|----------------------------------|---------------------------|-------------------------|
| GND                              | ±4 kV Level 4 protection  | Yes, Class B compliance |

**IEC 61000-4-6 CONDUCTED RF IMMUNITY TESTING**

The EVAL-ADM3095EEBZ was lab tested and certified to pass IEC 61000-4-6 conducted RF immunity testing to Level 3 (10 V/m rms). The IEC 61000-4-6 conducted immunity test is applicable to products that operate in environments where RF fields are present, and where they are connected to the mains power supplies or other networks (signal or control lines). The source of conducted disturbances are electromagnetic fields, emanating from RF transmitters that can act on the whole length of cables connected to the installed equipment. In the IEC 61000-4-6 test, a RF voltage swept and stepped from 150 kHz to 80 MHz. The RF voltage was amplitude modulated 80% at 1 kHz. The RF voltage was applied to the EUT (one EVAL-ADM3095EEBZ) using a clamp, as specified in Table 5. The clamp was placed on a communications cable between two EVAL-ADM3095EEBZ evaluation boards. The EVAL-

ADM3095EEBZ was tested to Level 3, which is the highest test level of 10 V/m rms. For all testing, the equipment and the EUT setup is described in Table 5 and Figure 6. Table 5 details the Class A compliance of the ADM3095E to IEC 61000-4-6 conducted RF immunity.

For all tests, the IEC 61000-4-6 clamp was placed at the EVAL-ADM3095EEBZ EUT, and the cable shield was either floating or earthed. The second EVAL-ADM3095EEBZ (auxiliary equipment) was placed on the network to terminate the communications bus. Table 6 shows the test results where the EUT passed IEC 61000-4-6 to Level 3.

For a shielded cable, these test results are valid for setups with or without an RS-485 cable shield connection to GND. The test results are also valid for using an unshielded twisted pair cable (with no shielded braid).

**Table 5. IEC 61000-4-6 Conducted RF Immunity Equipment Under Test (EUT) and Equipment**

| Parameter                | Details   |
|--------------------------|---|
| IEC 61000-4-6 Clamp      | Schaffner KEMZ 801, placed at 30 cm away from the EUT                                   |
| IEC 61000-4-6 Test Level | Level 3, 0.15 MHz to 100 MHz, 10 V/m rms, 80% amplitude modulated by a 1 kHz sinusoidal |
| EUT                      | EVAL-ADM3095EEBZ  |
| EUT Data Rate            | 2.0 Mbps  |
| EUT Power                | VCC and VIO powered at 5 V  |
| Cable Between EUT        | 5 meters, Unitronic ProfiBus, 22 American wire gauge (AWG) shielded cable               |
| Cable Termination        | 120 Ω resistor at both cable ends   |
| Pass and Fail Criteria   | Pass: data at receiver with a pulse width distortion within 10% of mean                 |
| Pass Classification      | Class A compliance  |

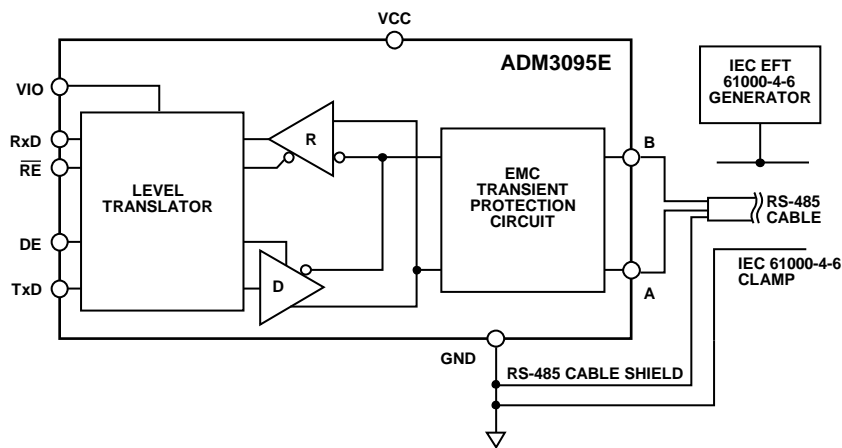

Figure 6. IEC 61000-4-6 Conducted RF Immunity Example Test Setup

**Table 6. IEC 61000-4-6 Conducted RF Immunity Certified Test Results**

| Clamp Location | Cable Shield                      | Current Return Path | IEC 61000-4-6 Test Frequency (MHz) | Certified Result |
|----------------|-----------------------------------|---------------------|------------------------------------|------------------|
| 30 cm from EUT | Floating                          | GND                 | 0.15 to 80                         | Pass             |
| 30 cm from EUT | Earthed                           | GND                 | 0.15 to 80                         | Pass             |
| 30 cm from EUT | Not applicable (unshielded cable) | GND                 | 0.15 to 80                         | Pass             |

**±42 V MISWIRE PROTECTION**

The [ADM3095E](#) is protected against high voltage miswire events when it operates on a bus that does not have RS-485 termination or bus biasing resistors installed. A typical miswire event is where a high voltage ac/dc power supply is connected directly to the RS-485 bus pin connectors. The [ADM3095E](#) can withstand miswiring faults of up to  $\pm 42 V_{PEAK}$  on RS-485 bus pins with respect to GND without damage.

Miswiring protection is guaranteed on the [ADM3095E](#) RS-485 bus A and B pins and is guaranteed in the case of a hot swap of connectors to the bus pins. Table 7 provides a summary of the high voltage miswire protection offered by the [ADM3095E](#). The [ADM3095E](#) was tested with  $\pm 42 V$  dc and to  $\pm 24 V \pm 20\%$  rms, 50 Hz/60 Hz, with both a hot plug and dc ramp test waveforms. The test was performed in both powered and unpowered/ floating power supply cases and at a range of different states for the RS-485 TxD input and DE/ $\overline{RE}$  enable pins. The RS-485 bus pins survive a high voltage miswire from Pin A to GND, from Pin B to GND, and between Pin A and Pin B.

**Table 7. High Voltage Miswire Protection**

| Supply <sup>1</sup> |     | Inputs <sup>2</sup> |                 |     | Miswire Protection at RS-485 Output Pins <sup>3,4</sup> |
|---------------------|-----|---------------------|-----------------|-----|---|
| Vcc                 | Vio | DE                  | $\overline{RE}$ | TxD |   |
| X                   | X   | H/L                 | H/L             | H/L | $-42 V \text{ dc} \leq V_A \leq +42 V \text{ dc}$       |
| X                   | X   | H/L                 | H/L             | H/L | $-42 V \text{ dc} \leq V_B \leq +42 V \text{ dc}$       |
| X                   | X   | H/L                 | H/L             | H/L | $-42 V \text{ ac} \leq V_A \leq +42 V \text{ ac}$       |
| X                   | X   | H/L                 | H/L             | H/L | $-42 V \text{ ac} \leq V_B \leq +42 V \text{ ac}$       |

<sup>1</sup> X equals on or off power supply state.

<sup>2</sup> H equals high level for logic pin, and L equals low level for logic pin.

<sup>3</sup> This is the ac/dc peak miswire voltage between Pin A and GND, Pin B and GND, or between Pin A and Pin B.

<sup>4</sup>  $V_A$  refers to the voltage on Pin A, and  $V_B$  refers to the voltage on Pin B.

# EVALUATION BOARD SCHEMATIC

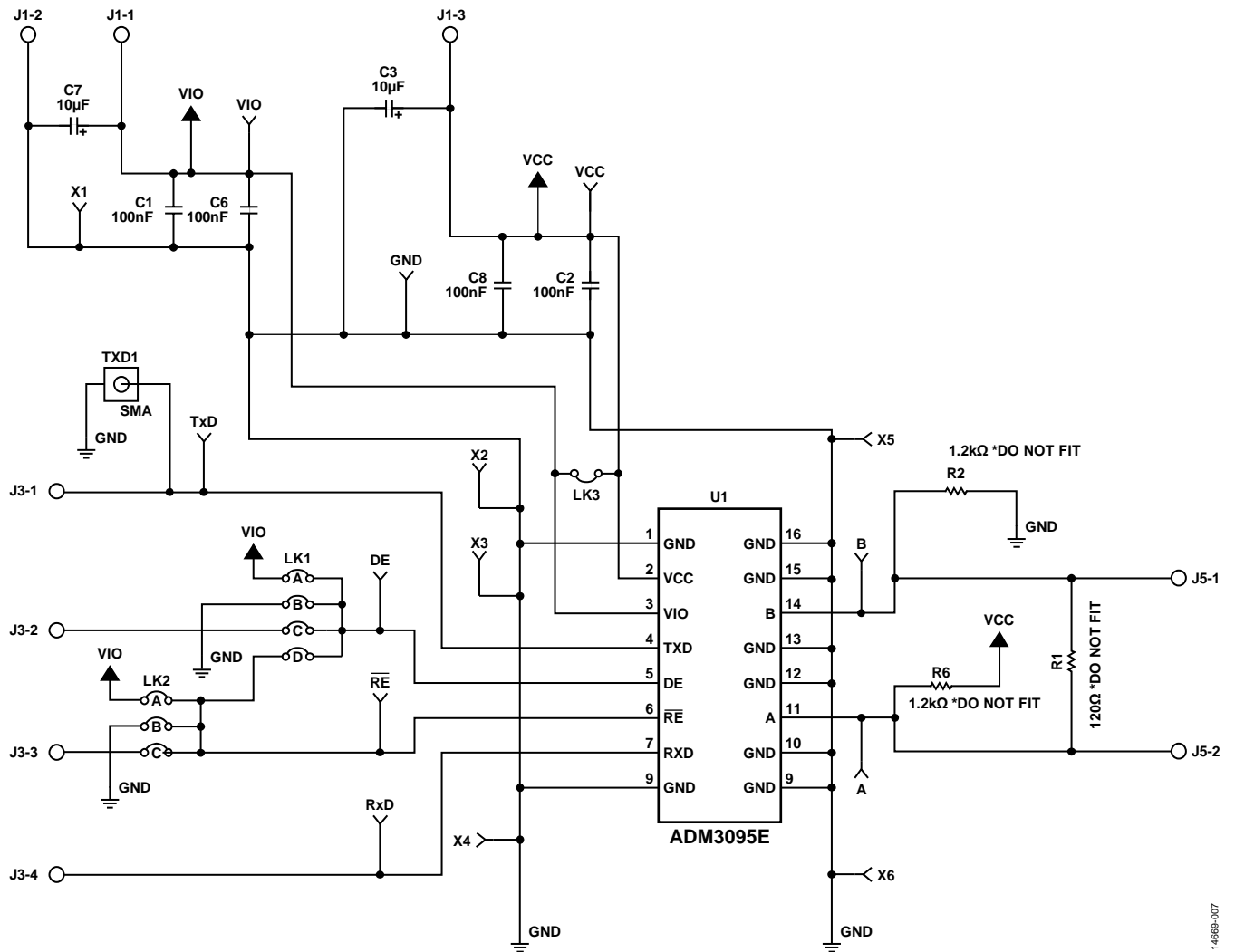

Figure 7. EVAL-ADM3095EEBZ Evaluation Board Schematic

14669-007

ASSEMBLY DRAWINGS AND BOARD LAYOUT

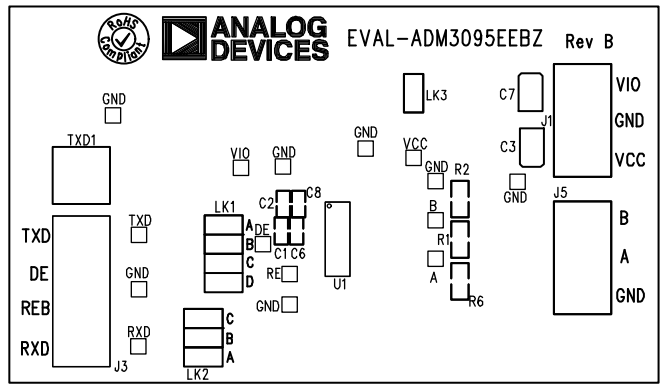

Figure 8. EVAL-ADM3095EEBZ Evaluation Board Silkscreen

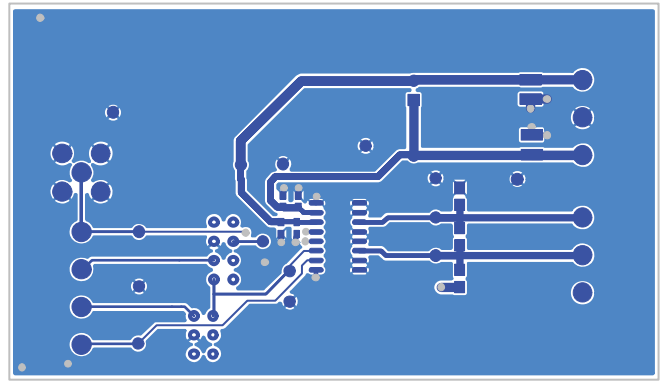

Figure 9. EVAL-ADM3095EEBZ Evaluation Board Top Layer

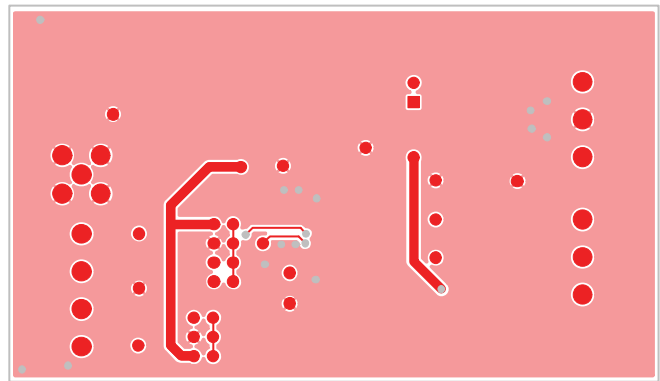

Figure 10. EVAL-ADM3095EEBZ Evaluation Board Bottom Layer

# ORDERING INFORMATION

## BILL OF MATERIALS

Table 8.

| Qty. | Reference Designator   | Description  | Supplier                         | Part No.                    |
|------|------------------------|--|----------------------------------|-----------------------------|
| 4    | C1, C2, C6, C8         | Capacitors, size 0603, 100 nF  | AVX Corporation                  | 06033C104JAT2A              |
| 2    | C3, C7                 | Capacitors, tantalum, Case B, 10 µF  | KEMET                            | B45196H3106K209             |
| 1    | R1                     | Resistor, 120 Ω, size 0805 (do not fit)  | TT Electronics Welwyn Components | WCR0805-120RF1              |
| 2    | R2, R6                 | Resistors, 1.2 kΩ, size 0805 (do not fit)  | Panasonic                        | ERA6AEB122V                 |
| 1    | LK1                    | 8-pin (4 × 2), 2.54 mm header and shorting block                                       | Harwin                           | M20-9953646                 |
| 1    | LK2                    | 6-pin (3 × 2), 2.54 mm header and shorting block                                       | Harwin                           | M20-9983646                 |
| 1    | LK3                    | 2-pin (1 × 1), 2.54 mm header and shorting block                                       | Harwin                           | M20-9990246                 |
| 3    | J1                     | CON\POWER3, 3-pin terminal blocks  | CAMDEN                           | CTB5000/3                   |
| 1    | J3                     | CON\POWER4, 4-pin terminal block   | Lumberg                          | KRM 04                      |
| 2    | J5                     | CON\POWER3, 2-pin terminal blocks  | Lumberg                          | KRM 03                      |
| 7    | GND                    | Test points, black   | Vero Technologies                | 20-2137                     |
| 6    | A, B, DE, RE, RxD, TxD | Test points, yellow  | Vero Technologies                | 20-313140                   |
| 2    | VCC, VIO               | Test points, red   | Vero Technologies                | 20-313137                   |
| 1    | TXD1                   | RH SMA connector   | TE Connectivity                  | 5-1814400-1                 |
| 1    | U1                     | <a href="#">ADE3095E</a> Level 4 EMC and full ±42 V fault protected RS-485 transceiver | Analog Devices, Inc.             | <a href="#">ADM3095EBRZ</a> |



**ESD Caution**

**ESD (electrostatic discharge) sensitive device.** Charged devices and circuit boards can discharge without detection. Although this product features patented or proprietary protection circuitry, damage may occur on devices subjected to high energy ESD. Therefore, proper ESD precautions should be taken to avoid performance degradation or loss of functionality.

**Legal Terms and Conditions**

By using the evaluation board discussed herein (together with any tools, components documentation or support materials, the "Evaluation Board"), you are agreeing to be bound by the terms and conditions set forth below ("Agreement") unless you have purchased the Evaluation Board, in which case the Analog Devices Standard Terms and Conditions of Sale shall govern. Do not use the Evaluation Board until you have read and agreed to the Agreement. Your use of the Evaluation Board shall signify your acceptance of the Agreement. This Agreement is made by and between you ("Customer") and Analog Devices, Inc. ("ADI"), with its principal place of business at One Technology Way, Norwood, MA 02062, USA. Subject to the terms and conditions of the Agreement, ADI hereby grants to Customer a free, limited, personal, temporary, non-exclusive, non-sublicensable, non-transferable license to use the Evaluation Board FOR EVALUATION PURPOSES ONLY. Customer understands and agrees that the Evaluation Board is provided for the sole and exclusive purpose referenced above, and agrees not to use the Evaluation Board for any other purpose. Furthermore, the license granted is expressly made subject to the following additional limitations: Customer shall not (i) rent, lease, display, sell, transfer, assign, sublicense, or distribute the Evaluation Board; and (ii) permit any Third Party to access the Evaluation Board. As used herein, the term "Third Party" includes any entity other than ADI, Customer, their employees, affiliates and in-house consultants. The Evaluation Board is NOT sold to Customer; all rights not expressly granted herein, including ownership of the Evaluation Board, are reserved by ADI. CONFIDENTIALITY. This Agreement and the Evaluation Board shall all be considered the confidential and proprietary information of ADI. Customer may not disclose or transfer any portion of the Evaluation Board to any other party for any reason. Upon discontinuation of use of the Evaluation Board or termination of this Agreement, Customer agrees to promptly return the Evaluation Board to ADI. ADDITIONAL RESTRICTIONS. Customer may not disassemble, decompile or reverse engineer chips on the Evaluation Board. Customer shall inform ADI of any occurred damages or any modifications or alterations it makes to the Evaluation Board, including but not limited to soldering or any other activity that affects the material content of the Evaluation Board. Modifications to the Evaluation Board must comply with applicable law, including but not limited to the RoHS Directive. TERMINATION. ADI may terminate this Agreement at any time upon giving written notice to Customer. Customer agrees to return to ADI the Evaluation Board at that time. LIMITATION OF LIABILITY. THE EVALUATION BOARD PROVIDED HEREUNDER IS PROVIDED "AS IS" AND ADI MAKES NO WARRANTIES OR REPRESENTATIONS OF ANY KIND WITH RESPECT TO IT. ADI SPECIFICALLY DISCLAIMS ANY REPRESENTATIONS, ENDORSEMENTS, GUARANTEES, OR WARRANTIES, EXPRESS OR IMPLIED, RELATED TO THE EVALUATION BOARD INCLUDING, BUT NOT LIMITED TO, THE IMPLIED WARRANTY OF MERCHANTABILITY, TITLE, FITNESS FOR A PARTICULAR PURPOSE OR NON-INFRINGEMENT OF INTELLECTUAL PROPERTY RIGHTS. IN NO EVENT WILL ADI AND ITS LICENSORS BE LIABLE FOR ANY INCIDENTAL, SPECIAL, INDIRECT, OR CONSEQUENTIAL DAMAGES RESULTING FROM CUSTOMER'S POSSESSION OR USE OF THE EVALUATION BOARD, INCLUDING BUT NOT LIMITED TO LOST PROFITS, DELAY COSTS, LABOR COSTS OR LOSS OF GOODWILL. ADI'S TOTAL LIABILITY FROM ANY AND ALL CAUSES SHALL BE LIMITED TO THE AMOUNT OF ONE HUNDRED US DOLLARS (\$100.00). EXPORT. Customer agrees that it will not directly or indirectly export the Evaluation Board to another country, and that it will comply with all applicable United States federal laws and regulations relating to exports. GOVERNING LAW. This Agreement shall be governed by and construed in accordance with the substantive laws of the Commonwealth of Massachusetts (excluding conflict of law rules). Any legal action regarding this Agreement will be heard in the state or federal courts having jurisdiction in Suffolk County, Massachusetts, and Customer hereby submits to the personal jurisdiction and venue of such courts. The United Nations Convention on Contracts for the International Sale of Goods shall not apply to this Agreement and is expressly disclaimed.

©2017 Analog Devices, Inc. All rights reserved. Trademarks and registered trademarks are the property of their respective owners. UG14669-0-3/17(0)



www.analog.com

## Looking for pricing, stock, or lifecycle information?

Click below to explore more details on WIN SOURCE:

- ⊖ [View EVAL-ADM3095EEBZ on WIN SOURCE](#)
- ⊖ [Analog Devices Inc. Information](#)

## Optimize Your Supply Chain with WIN SOURCE Solutions

- ✓ Global Sourcing Solution
- ✓ Obsolete Management
- ✓ Cost Control Management
- ✓ Shortage Management
- ✓ Alternative Solution
- ✓ Excess Inventory Management