



**THE DATASHEET OF
EV-ADF4360-8EB1Z**



Evaluation Board for the **ADF4360-8** Integrated PLL and VCO Frequency Synthesizer

FEATURES

- Self-contained board for generating RF frequencies
- Flexibility for reference input, PFD frequency, and loop bandwidth
- Accompanying software allows complete control of synthesizer functions from a PC
- Flexibility for changing external inductor to allow different VCO output frequency ranges
- USB-/battery-operated 9 V supplies

GENERAL DESCRIPTION

The **EV-ADF4360-8EB1Z** board is designed to allow the user to evaluate the performance of the ADF4360-8 frequency synthesizer consisting of an integrated PLL and VCO (see Figure 1). It contains the **ADF4360-8BCPZ**, a USB connector, and SMA connectors for the RF outputs. Unpopulated SMA footprints are available for the power supplies, the chip enable (CE), and the external reference input. The evaluation board also contains the loop filter to complete the PLL. It can be modified as necessary for the user's PLL requirements. A USB cable is included with the board to allow software programmability.

The package also contains a CD with Windows® software to allow quick, user-friendly programming of the synthesizer. The CD contains numerous other PLL data sheets, technical notes, articles, and ADIsimPLL™ V3.4, Analog Devices, Inc., PLL simulation software. More information is available at www.analog.com/pll.

EVALUATION BOARD PHOTOGRAPH



Figure 1.

TABLE OF CONTENTS

Features 1
 General Description 1
 Evaluation Board Photograph..... 1
 Revision History 2
 Evaluation Board Hardware 3
 RF Output Stage..... 3
 External Inductor Options 3
 Evaluation Board Software Quick Start Procedures 5

Windows XP OS5
 Windows Vista OS and Windows 7 (32-Bit) OS.....5
 Windows 7 (64-Bit) OS6
 Using the Evaluation Board Software7
 Evaluation Board Schematics.....9
 Ordering Information 12
 Bill of Materials..... 12
 Related Links..... 13

REVISION HISTORY

2/12—Rev. A to Rev. B
 Changed EVAL-ADF4360-8EBZ1 to EV-ADF4360-8EB1Z
 Throughout 1

11/11—Rev. 0 to Rev. A
 Changes to Features Section, General Description Section, and
 Figure 1 1
 Changes to Evaluation Board Hardware Section and Figure 2 .. 3
 Deleted Figure 3; Renumbered Sequentially..... 3
 Changes to External Inductor Options Section and Figure 3..... 3
 Replaced Evaluation Board Software Section with Evaluation
 Board Software Quick Start Procedures Section 5

Added Figure 5, Figure 6, and Figure 7; Renumbered
 Sequentially5
 Added Figure 8 and Figure 9.....6
 Replaced Programmable Software Settings Section with Using
 the Evaluation Board Software Section7
 Changes to Figure 10.....8
 Changes to Figure 11.....9
 Changes to Figure 12..... 10
 Changes to Figure 13..... 11
 Changes to Table 1..... 12

8/10—Revision 0: Initial Version

EVALUATION BOARD HARDWARE

The evaluation board comes with a cable to connect to the USB port of a PC. The silkscreen for the evaluation board is shown in Figure 2. The board schematics are shown in Figure 11, Figure 12, and Figure 13.

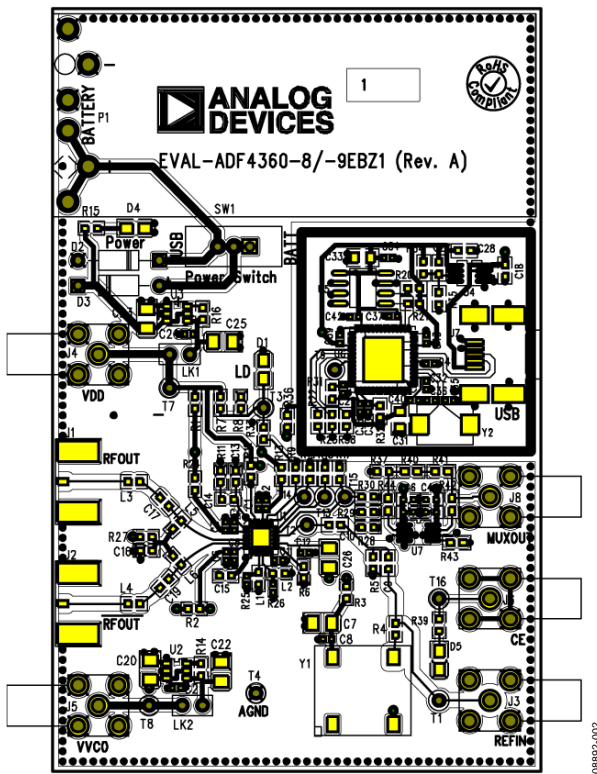

Figure 2. Evaluation Board Silkscreen—Top View

The board is powered from a single 9 V battery or from the USB supply by changing the position of Switch SW1. All components necessary for LO generation are catered for on board. A 10 MHz TCXO from Fox Electronics provides the necessary reference input. Otherwise, an external reference signal can be connected via J3. The PLL comprises the ADF4360-8BCPZ and a passive loop filter. The VCO output from RF_{OUTA} is available through the standard SMA connector, J1, and the complementary RF_{OUTB} VCO output is available from J2.

Users can provide their own power supplies using the J4 and J5 connectors, as shown in Figure 2. Hardware power-down using the CE pin can be controlled by inserting an SMA connector into J6 and removing R12.

The on-board filter is a third-order, passive, low-pass filter. The filter contains three capacitors (C13, C14, and C15) plus two resistors (R10 and R11). The footprint for R10 is located on the underside of the board. The design parameters for the loop filter are for a center frequency of 120 MHz, a PFD frequency of 1 MHz, and a low-pass filter bandwidth of 40 kHz. To design a filter for different frequency setups, use the ADIsimPLL simulation software.

RF OUTPUT STAGE

The RF output stage of the board allows the user to insert a tuned load for a particular frequency. The particular network inserted in the board is optimized for 120 MHz operation. For different frequencies, the output stage needs different component values. Consult the ADF4360-8 data sheet for further information. If in doubt, use a 50 Ω resistor instead of the shunt inductor and a 100 pF bypass capacitor and a 0 Ω resistor instead of the series inductor.

It is important that the same components be placed on the RF_{OUTA} and RF_{OUTB} lines. In addition, it is essential that both outputs be terminated with 50 Ω loads. Otherwise, the output power is not optimal, and, in some cases, the part may malfunction.

In applications that only use the divider, both RF outputs are best terminated with a shunt 50 Ω resistor to AV_{DD}, a series 100 pF dc bypass capacitor, and a 50 Ω load to GND.

EXTERNAL INDUCTOR OPTIONS

The ADF4360-8 uses external inductors (L1 and L2) to set up the LC tank circuit of the VCO. The evaluation board has a footprint for the placement of these. A value of 220 nH is inserted on the board giving a VCO center frequency of 120 MHz. Insert two 470 Ω resistors (R25 and R26) parallel to ground for both L1 and L2 (see Figure 3).

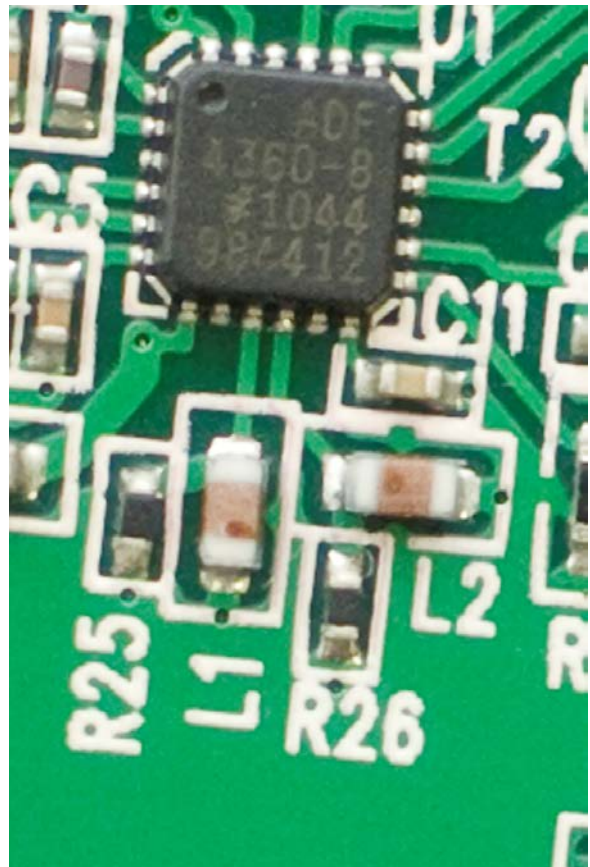

Figure 3. External Inductors and Resistors for the ADF4360-8 Tank Circuit

To find the optimum frequency range for a given inductor, see Figure 4. Ensure that the desired frequency is between the two lines and determine the appropriate inductance needed.

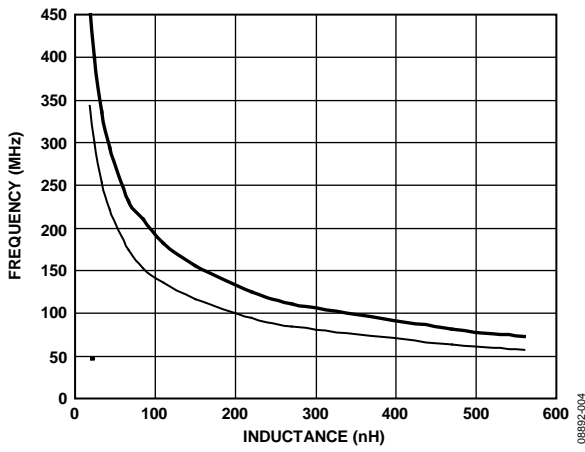

Figure 4. Output Center Frequency vs. External Inductor Value

EVALUATION BOARD SOFTWARE QUICK START PROCEDURES

The control software and USB drivers for [EV-ADF4360-8EB1Z](#) accompany the [EV-ADF4360-8EB1Z](#) on a CD. To install the software, use the following steps:

1. Open `ADF4360_setup.msi`.
2. The install wizard guides you through the installation process. The software is installed in a default directory called `C:/Program Files/Analog Devices/ADF4360`.

The software requires Microsoft's .NET Framework Version 3.5 or later to be installed on your machine. The installer automatically downloads the framework from the Microsoft website if you do not have this installed. If you do not have an Internet connection or have a slow connection on the PC, you can install the .NET framework directly from the CD. Do this by double-clicking `dotnetfx.exe`. Once installed, run `ADF4360_Setup.msi` again.

WINDOWS XP OS

After you have installed the software, install the USB drivers. To do so, use the following steps:

1. Plug a USB cable into the USB connector on the evaluation board. The **Found New Hardware** box opens. See Figure 5.
2. Choose **Install from a list or specified location (Advanced)**.



Figure 5. New Hardware Wizard

3. Click **Continue Anyway** when asked about Windows Logo testing.

If the installation is successful, the message in Figure 6 appears.



Figure 6. Successful Installation

WINDOWS VISTA OS AND WINDOWS 7 (32-BIT) OS

For Windows Vista or Windows 7 (32-bit), you must manually install the drivers. To do so, use the following steps:

1. Find the new unknown device (the evaluation board) in **Device Manager** and double-click it to open the properties. The device should be **Unknown device**, under **Other devices** (see Figure 7).

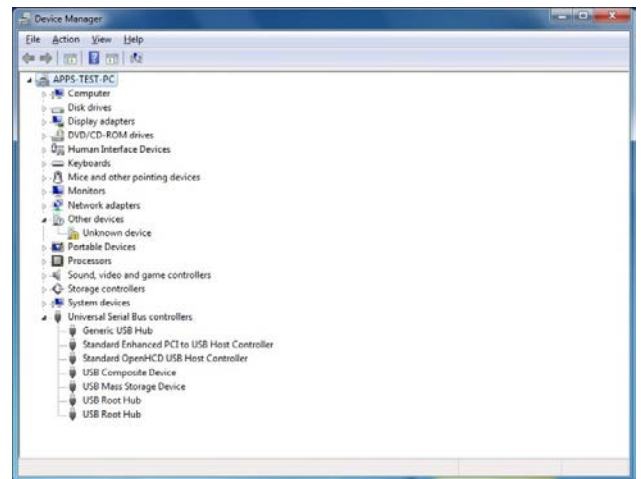

Figure 7. Device Manager

- Click **Update Driver** in the properties window (see Figure 8).

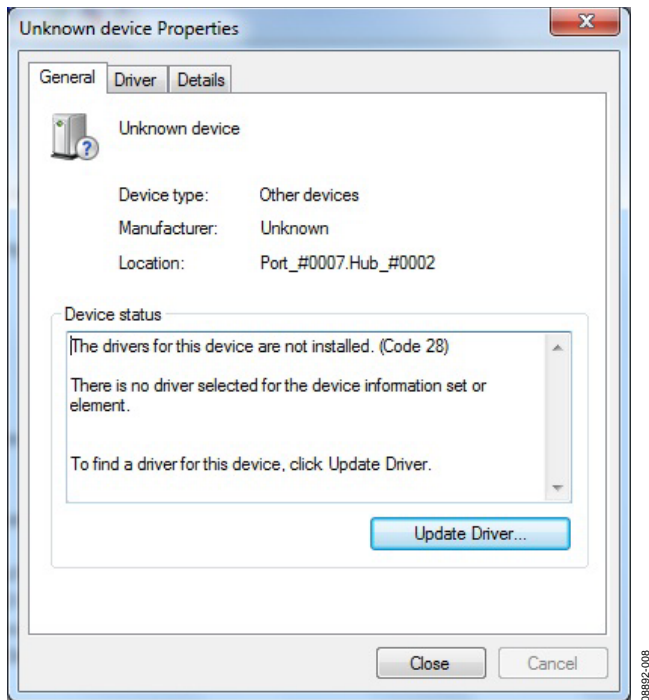

Figure 8. Unknown Device Properties

- On the **Update Driver Software** dialog box, choose **Browse my computer for driver software**.
- Browse to **C:\Program Files\Analog Devices\ADF4360**.
- Click **OK** or **Next**.
- If prompted by Windows security, choose **Install this driver software anyway**.
- If the installation is successful, the message in Figure 9 appears.

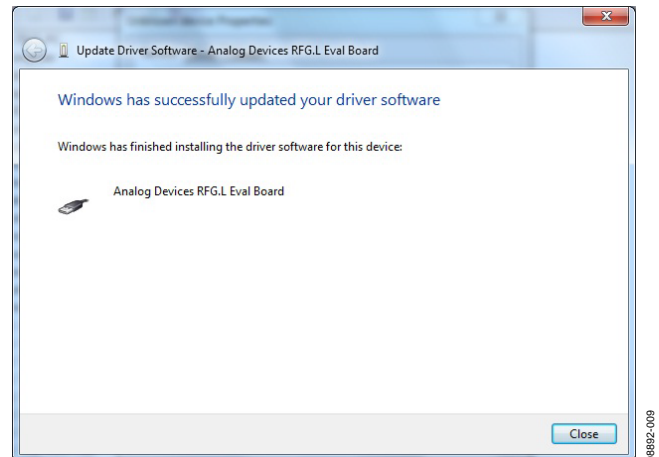

Figure 9. Successful Installation

WINDOWS 7 (64-BIT) OS

Windows 7 64-bit uses a different driver than 32-bit systems. To install this driver:

- Disconnect the USB evaluation board.
- Open **ADF4360_setup.msi**.
- The install wizard guides you through the installation process. The software is installed in a default directory called **C:\Program Files\Analog Devices\ADF4360**.
- Connect your USB evaluation board. The driver should be found automatically.

Note that installing this driver package disables older versions of Analog Devices PLL software; therefore, only install if needed.

USING THE EVALUATION BOARD SOFTWARE

The control software for the [EV-ADF4360-8EB1Z](#) accompanies the [EV-ADF4360-8EB1Z](#) on a CD. To install the software, see the Evaluation Board Software Quick Start Procedures section.

To run the software, double-click the **ADF4360.exe** file on the desktop or from the **Start** menu.

The main interface window opens (see Figure 10). Confirm that **Analog Devices RFG.L Eval Board connected** is displayed at the top of the window. Otherwise, the software has no connection to the evaluation board.

The evaluation board can be connected and disconnected while the software is running. Note that, when connecting the board, it takes about 5 seconds for the status label to change.

Under the **File** menu, the current settings can be saved to, and loaded from, a text file.

Use the **REF IN Frequency** text box to set the correct reference frequency and the reference frequency divider. The reference TCXO on the evaluation board runs at 10 MHz.

The **Settings** section controls the charge pump current setting, the output power setting, and the multiplexer output setting.

Use the **Frequency Settings** section to control the output frequency. You can input the desired output frequency in the **RF Output Frequency** text box (in megahertz).

In the **Registers** tab, you can manually input the desired value to be written to the registers.

In the **Sweep and hop** tab, you can make the device sweep a range of frequencies or hop between two set frequencies.

In the **Latches to write** section at the bottom of the window, the values to be written to each register are displayed. If the background on the text box is green, the value displayed is different from the value actually on the device. Click **Write N counter Latch** or **Write R counter Latch** to write that value to the device.

Press the **F2**, **F3**, and **F4** keys to switch between the three tabs. **F12** increases the output frequency by one channel spacing and writes it to the device. **F11** decreases the output frequency by one channel spacing.

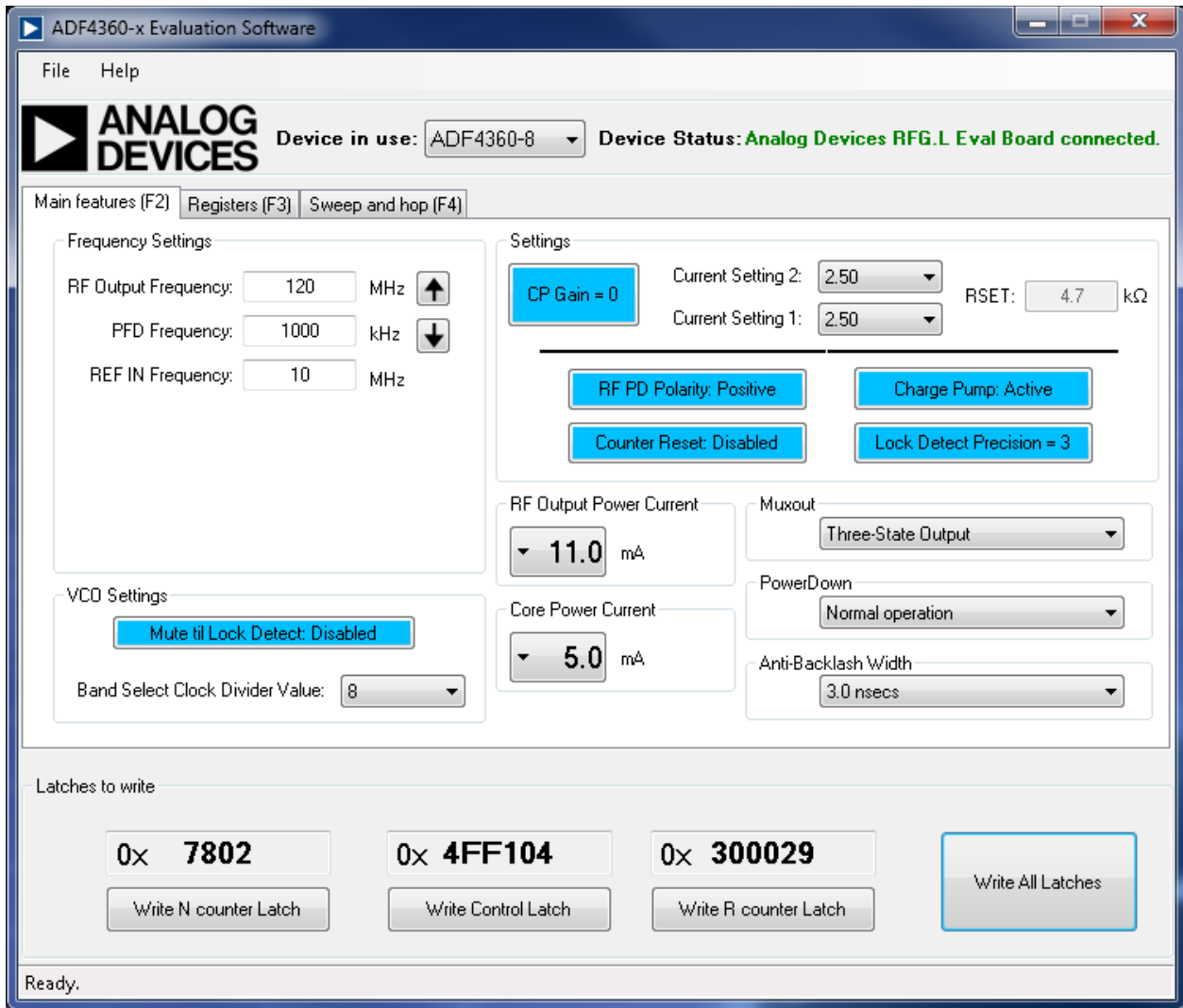

Figure 10. Software Front Panel Display

EVALUATION BOARD SCHEMATICS

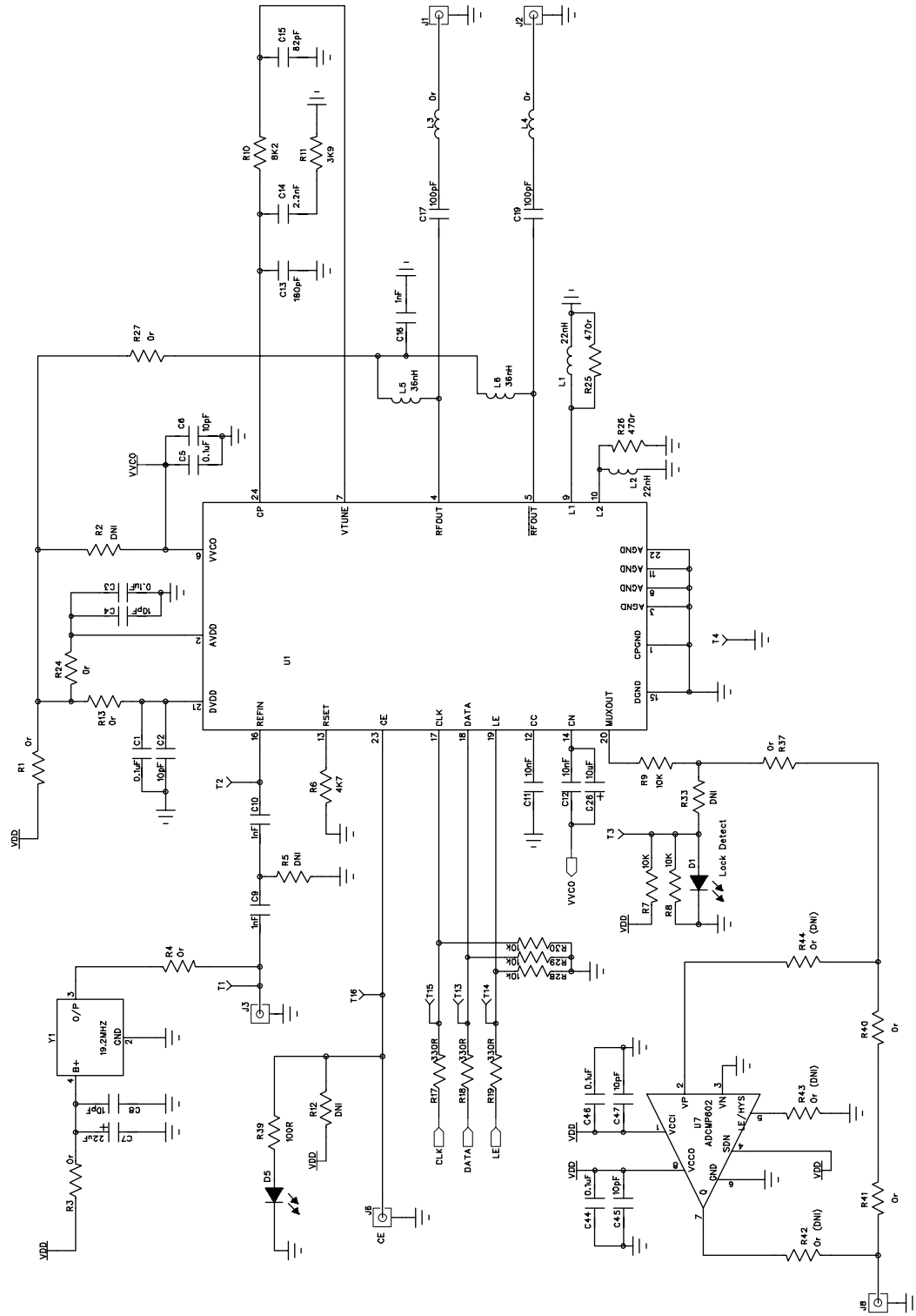
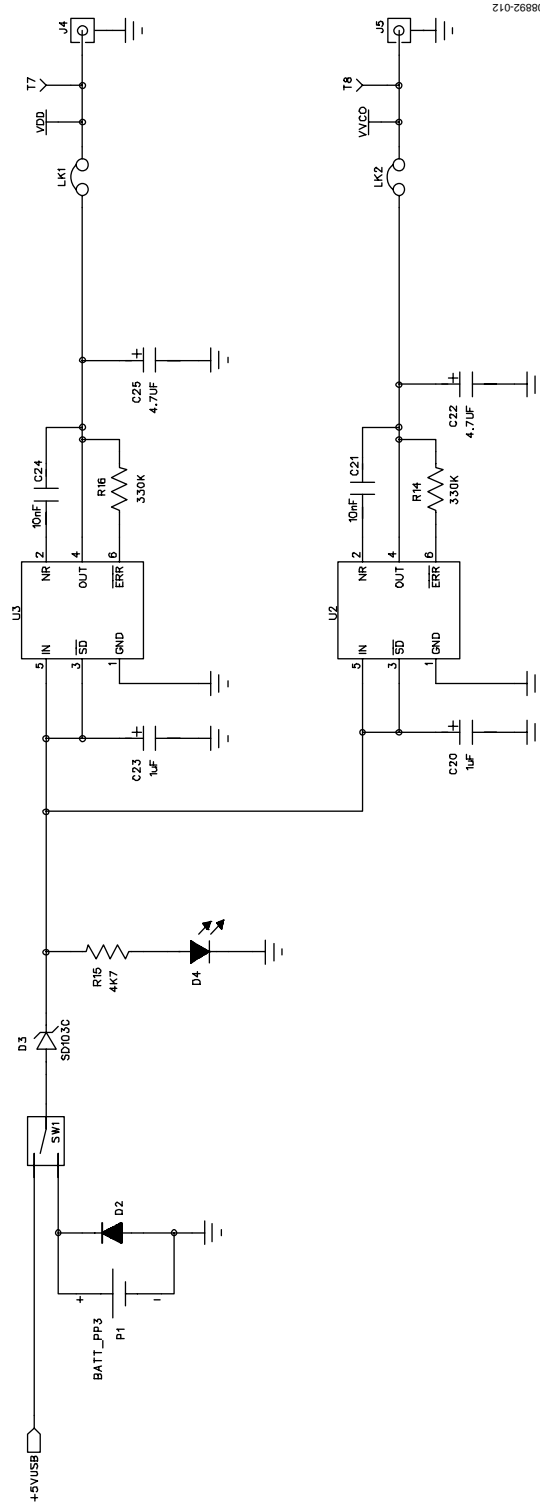

Figure 11. EV-ADF4360-8EB1Z Schematic



08892-012

Figure 12. EV-ADF4360-8EB1Z Schematic (Continued)

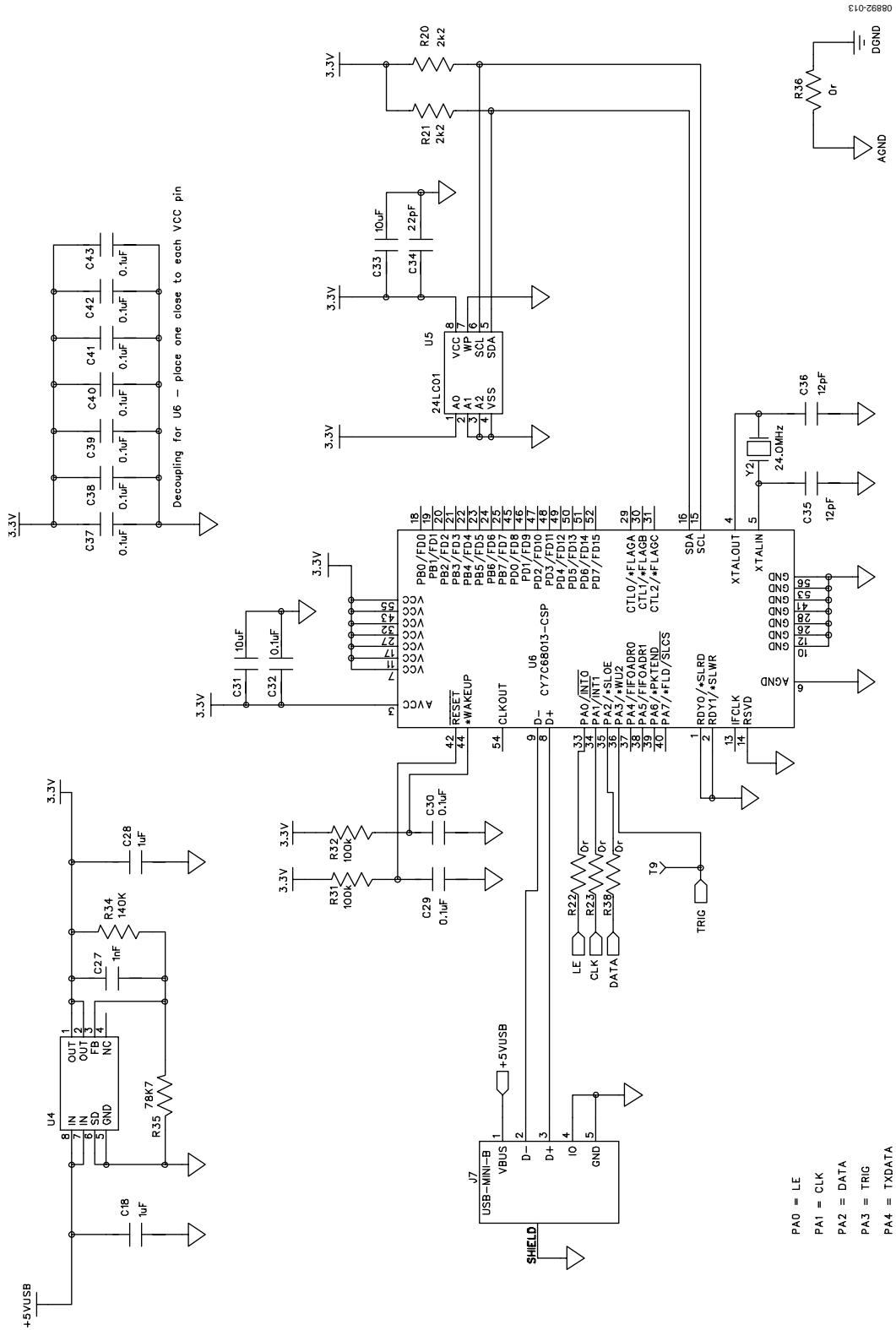

Figure 13. EV-ADF4360-8EB1Z Schematic (Continued)

ORDERING INFORMATION

BILL OF MATERIALS

Table 1.

Reference Designator	Part Description	Manufacturer/Part No.
C1, C3, C5, C29, C30, C32, C37, C38, C39, C40, C41, C42, C43	Capacitor, 0402, 0.1 μ F, 16 V	Kemet C0402C104K4RAC
C2, C4, C6, C8	Capacitor, 0402, 10 pF, 50 V	Kemet C0402C100J5GACTU
C7	Capacitor, Case A, 22 μ F, 6.3 V	AVX TAJA226K006R
C9, C10, C27	Capacitor, 0603, 1 nF, 50 V	AVX 06035A102JAT2A
C11, C12, C21, C24	Capacitor, 0402, 10 nF, 16 V	Yageo (Phycomp) CC0402ZRY5V7BB103
C13	2-pin capacitor, 120 pF, 0603, 50 V	Yageo CC0603KRX7R9BB121
C14	2-pin capacitor, 1.5 nF, 0603, 50 V	Yageo CC0603KRX7R9BB152
C15	2-pin capacitor, 47 pF, 0603, 50 V	Yageo CC0603JRNPO9BN470
C16	Multilayer ceramic capacitor, 50 V, X7R, 1 nF, \pm 10%, 0402	Murata GRM155R71H102KA01D
C17, C19	Capacitor, 0603, 100 pF, 50 V	Phycomp 2238 867 15101
C18, C28	Capacitor 0603, 1 μ F, 25 V	Taiyo Yuden TMK107BJ105KA-T
C20, C23	Capacitor, Case A, 1 μ F, 16 V	AVX TAJA105K016R
C22, C25	Capacitor, Case A, 4.7 μ F, 10 V	AVX TPSA475K010R1400
C26	Capacitor, Case A, 10 μ F, 6.3 V	Kemet T491A106M016AT
C31, C33	Capacitor, 0805, 10 μ F, 6.3 V	Murata GRM21BR71A106KE51L
C34	Capacitor, 0402, 22 pF, 50 V NPO	Kemet C0402C220J5GACTU
C35, C36	Capacitor 0402, 12 pF, 50V	Kemet C0402C120J5GACTU
D1	LED, SMD red	Avago HSMS-C170
D2	Diode, 1 A, 50 V	Multicomp 1N4001
D3	Schottky diode, 20 V	Micro Commercial Components, Inc., SD103C-TP
D4	LED, SMD red	Avago HSMS-C170
J1, J2	Jack SMA end launch tab	Johnson Components 142-0701-851
J3 to J6	Jack SMA end launch tab (not inserted)	
J7	USB mini-B	Molex 56579-0576
L1, L2	Ceramic chip inductor, 220 nH, 5%, 0603 for ADF4360-8	Coilcraft 0603CS-R22X_L
L3, L4	Resistor, 0603, 0 Ω	Multicomp MC 0.063W 0603 0R
L5, L6	Ceramic chip inductor, 240 nH, 5%, 0603	Coilcraft 0603LS-36NX_LU
LK1, LK2	Header, 1-row, 2-way and jumper socket black	Harwin Plc M20-9990245 and Harwin Plc M7567-05
P1	Battery clip, PCB mounting	Keystone Electronics Corp. 593+594
R1 to R4, R9, R13, R22 to R24	Resistor, 0603, 0 Ω	Multicomp MC 0.063W 0603 0R
R27, R36, R37, R40, R41, R38, R5	Resistor, 0603, 51 Ω	Multicomp MC 0.063W 0603 1% 51R
R6, R15	Resistor, 0603, 4.7 k Ω	Multicomp MC 0.063W 0603 1% 4K7
R7, R8, R12, R28, R29, R30	Resistor, 0603, 10 k Ω	Multicomp MC 0.063W 0603 1% 10K
R10	2-pin resistor, 12 k Ω , 0603, 1%	Multicomp MC 0.063W 0603 1% 12K
R11	2-pin resistor, 5.1 k Ω , 0603, 1%	Multicomp MC 0.063W 0603 1% 5K1
R14, R16	Resistor, 0603, 330 k Ω	Multicomp MC 0.063W 0603 1% 330K
R17 to R19	Resistor, 0603, 330 Ω	Multicomp MC 0.063W 0603 1% 330R
R20, R21	Resistor, 0603, 2.2 k Ω	Multicomp MC 0.063W 0603 1% 2K2
R25, R26	Resistor, 0402, 470 Ω	Multicomp MC 0.063W 0402 1% 470R
R31, R32	Resistor, 0603, 100 k Ω	Multicomp MC 0.063W 0603 1% 100K
R34	Resistor, 0603, 140 k Ω	Multicomp MC 0.063W 0603 1% 140K
R35	Resistor, 0603, 78.7 k Ω	Multicomp MC 0.063W 0603 1% 78K7
SW1	Switch, PCB SPDT	APEM TL36P0050
T1 to T8, T13 to T16	Terminal, PCB, red, PK100	Vero Technologies, Ltd. 20-313137
T9 to T12	Test point (not inserted)	

Reference Designator	Part Description	Manufacturer/Part No.
U1	Integrated integer-N synthesizer	Analog Devices ADF4360-8BCPZ
U2, U3	High accuracy low dropout linear 3 V regulator	Analog Devices ADP3300ARTZ-3
U4	ADP3334 adjustable LDO regulator	Analog Devices ADP3334ARMZ
U5	IC serial EEPROM 8-SOIC	Microchip 24LC64-ISN
U6	USB microcontroller	Cypress CY7C68013A-56LFXC
U7	ADCMP602 comparator	Not inserted
Y1	10 MHz TCXO (FOX801)	Fox Electronics FOX801-BELF

RELATED LINKS

Resource	Description
ADF4360-8	Product Page, Integrated Integer-N Synthesizer and VCO—Output Frequency 65 MHz to 400 MHz
ADP3300	Product Page, High Accuracy anyCAP® 50 mA Low Dropout Linear Regulator
ADP3334	Product Page, High Accuracy Low IQ, 500 mA anyCAP® Adjustable Low Dropout Regulator
ADCMP602	Product Page, Rail-to-Rail, Very Fast, 2.5 V to 5.5 V, Single-Supply TTL/CMOS Comparator in 8-Lead MSOP and LSCFP Packages

NOTES

NOTES

NOTES

**ESD Caution**

ESD (electrostatic discharge) sensitive device. Charged devices and circuit boards can discharge without detection. Although this product features patented or proprietary protection circuitry, damage may occur on devices subjected to high energy ESD. Therefore, proper ESD precautions should be taken to avoid performance degradation or loss of functionality.

Legal Terms and Conditions

By using the evaluation board discussed herein (together with any tools, components documentation or support materials, the "Evaluation Board"), you are agreeing to be bound by the terms and conditions set forth below ("Agreement") unless you have purchased the Evaluation Board, in which case the Analog Devices Standard Terms and Conditions of Sale shall govern. Do not use the Evaluation Board until you have read and agreed to the Agreement. Your use of the Evaluation Board shall signify your acceptance of the Agreement. This Agreement is made by and between you ("Customer") and Analog Devices, Inc. ("ADI"), with its principal place of business at One Technology Way, Norwood, MA 02062, USA. Subject to the terms and conditions of the Agreement, ADI hereby grants to Customer a free, limited, personal, temporary, non-exclusive, non-sublicensable, non-transferable license to use the Evaluation Board FOR EVALUATION PURPOSES ONLY. Customer understands and agrees that the Evaluation Board is provided for the sole and exclusive purpose referenced above, and agrees not to use the Evaluation Board for any other purpose. Furthermore, the license granted is expressly made subject to the following additional limitations: Customer shall not (i) rent, lease, display, sell, transfer, assign, sublicense, or distribute the Evaluation Board; and (ii) permit any Third Party to access the Evaluation Board. As used herein, the term "Third Party" includes any entity other than ADI, Customer, their employees, affiliates and in-house consultants. The Evaluation Board is NOT sold to Customer; all rights not expressly granted herein, including ownership of the Evaluation Board, are reserved by ADI. CONFIDENTIALITY. This Agreement and the Evaluation Board shall all be considered the confidential and proprietary information of ADI. Customer may not disclose or transfer any portion of the Evaluation Board to any other party for any reason. Upon discontinuation of use of the Evaluation Board or termination of this Agreement, Customer agrees to promptly return the Evaluation Board to ADI. ADDITIONAL RESTRICTIONS. Customer may not disassemble, decompile or reverse engineer chips on the Evaluation Board. Customer shall inform ADI of any occurred damages or any modifications or alterations it makes to the Evaluation Board, including but not limited to soldering or any other activity that affects the material content of the Evaluation Board. Modifications to the Evaluation Board must comply with applicable law, including but not limited to the RoHS Directive. TERMINATION. ADI may terminate this Agreement at any time upon giving written notice to Customer. Customer agrees to return to ADI the Evaluation Board at that time. LIMITATION OF LIABILITY. THE EVALUATION BOARD PROVIDED HEREUNDER IS PROVIDED "AS IS" AND ADI MAKES NO WARRANTIES OR REPRESENTATIONS OF ANY KIND WITH RESPECT TO IT. ADI SPECIFICALLY DISCLAIMS ANY REPRESENTATIONS, ENDORSEMENTS, GUARANTEES, OR WARRANTIES, EXPRESS OR IMPLIED, RELATED TO THE EVALUATION BOARD INCLUDING, BUT NOT LIMITED TO, THE IMPLIED WARRANTY OF MERCHANTABILITY, TITLE, FITNESS FOR A PARTICULAR PURPOSE OR NON-INFRINGEMENT OF INTELLECTUAL PROPERTY RIGHTS. IN NO EVENT WILL ADI AND ITS LICENSORS BE LIABLE FOR ANY INCIDENTAL, SPECIAL, INDIRECT, OR CONSEQUENTIAL DAMAGES RESULTING FROM CUSTOMER'S POSSESSION OR USE OF THE EVALUATION BOARD, INCLUDING BUT NOT LIMITED TO LOST PROFITS, DELAY COSTS, LABOR COSTS OR LOSS OF GOODWILL. ADI'S TOTAL LIABILITY FROM ANY AND ALL CAUSES SHALL BE LIMITED TO THE AMOUNT OF ONE HUNDRED US DOLLARS (\$100,000). EXPORT. Customer agrees that it will not directly or indirectly export the Evaluation Board to another country, and that it will comply with all applicable United States federal laws and regulations relating to exports. GOVERNING LAW. This Agreement shall be governed by and construed in accordance with the substantive laws of the Commonwealth of Massachusetts (excluding conflict of law rules). Any legal action regarding this Agreement will be heard in the state or federal courts having jurisdiction in Suffolk County, Massachusetts, and Customer hereby submits to the personal jurisdiction and venue of such courts. The United Nations Convention on Contracts for the International Sale of Goods shall not apply to this Agreement and is expressly disclaimed.

Looking for pricing, stock, or lifecycle information?

Click below to explore more details on WIN SOURCE:

 [View EV-ADF4360-8EB1Z on WIN SOURCE](#)

 [Analog Devices Inc. Information](#)

Optimize Your Supply Chain with WIN SOURCE Solutions

-  Global Sourcing Solution
-  Obsolete Management
-  Cost Control Management
-  Shortage Management
-  Alternative Solution
-  Excess Inventory Management