



**THE DATASHEET OF
EVAL-ADAV4622EBZ**





**ANALOG
DEVICES**

Audio Processor for Advanced TV with Sound IF Demodulator and Stereo Decoder

ADAV4622

FEATURES

Sound IF (SIF) processor

- SIF demodulator and broadcast stereo decoder
- NICAM (BG, DK, I, L), A2 (BG, DK, M), BTSC (M, N), EIAJ (M)
- Automatic sound IF standard detection

Fully programmable 28-bit audio processor for enhanced

- ATV sound—default TV audio flow loaded on reset

Implements Analog Devices and third-party branded audio algorithms

Adjustable digital delay line for audio/video

- Synchronization for up to 200 ms stereo delay

High performance 24-bit ADC and DAC

- 94 dB DNR performance on DAC channels
- 95 dB DNR performance on ADC channels

- Dual headphone outputs with integrated amplifiers

High performance pulse-width modulation (PWM) digital outputs

Multichannel digital baseband I/O

- 4 stereo synchronous digital I²S input channels
- One 6-channel sample rate converter (SRC) and one stereo SRC supporting input sample rates from 5 kHz to 50 kHz
- One stereo synchronous digital I²S output
- S/PDIF output with S/PDIF input mux capability

Fast I²C control

Operates from 3.3 V (analog), 1.8 V (digital core), and 3.3 V (digital interface)

Available in 80-lead LQFP

APPLICATIONS

General-purpose consumer audio postprocessing

- Home audio
- DVD recorders
- Home theater in a box (HTIB) systems and DVD receivers

Audio processing subsystems for DTV-ready TVs

Analog broadcast capability for iDTVs

PRODUCT OVERVIEW

The ADAV4622 is an enhanced audio processor targeting advanced TV applications with full support for digital and analog baseband audio as well as multistandard broadcast SIF demodulation and decoding.

The audio processor, by default, loads a dedicated TV audio flow that incorporates full matrix switching (any input to any output), automatic volume control that compensates for volume changes during advertisements or when switching channels, dynamic bass, a multiband equalizer, and up to 200 ms of stereo delay memory for audio-video synchronization.

Alternatively, Analog Devices, Inc., offers an award-winning graphical programming tool (SigmaStudio™) that allows custom flows to be quickly developed and evaluated. This allows the creation of customer-specific audio flows, including use of the Analog Devices library of third-party algorithms.

The analog I/O integrates Analog Devices proprietary continuous-time, multibit Σ - Δ architecture to bring a higher level of performance to ATV systems, required by third-party algorithm providers to meet system branding certification. The analog input is provided by 95 dB dynamic range (DNR) ADCs, and analog output is provided by 94 dB DNR DACs.

The main speaker outputs can be supplied as a digitally modulated PWM stream to support digital amplifiers.

The ADAV4622 includes multichannel digital inputs and outputs. In addition, digital input channels can be routed through integrated sample rate converters (SRC), which are capable of supporting any arbitrary sample rate from 5 kHz to 50 kHz.

Advantiv
Advanced Television Solutions
by Analog Devices

Rev. B

Information furnished by Analog Devices is believed to be accurate and reliable. However, no responsibility is assumed by Analog Devices for its use, nor for any infringements of patents or other rights of third parties that may result from its use. Specifications subject to change without notice. No license is granted by implication or otherwise under any patent or patent rights of Analog Devices. Trademarks and registered trademarks are the property of their respective owners.

One Technology Way, P.O. Box 9106, Norwood, MA 02062-9106, U.S.A.
Tel: 781.329.4700 www.analog.com
Fax: 781.461.3113 ©2008–2009 Analog Devices, Inc. All rights reserved.

TABLE OF CONTENTS

Features	1	VREF	20
Applications	1	FILTA and FILTD	20
Product Overview	1	PWM1A, PWM1B, PWM2A, PWM2B, PWM3A, PWM3B, PWM4A, and PWM4B	20
Revision History	2	PWM_READY	20
Functional Block Diagram	3	AVDD	20
Specifications	4	DVDD	20
Performance Parameters	4	ODVDD	20
Timing Specifications	9	DGND	20
Timing Diagrams	10	AGND	20
Absolute Maximum Ratings	12	ODGND	20
Thermal Resistance	12	SIF_REFP, SIF_REFCM, and SIF_REFN	20
Thermal Conditions	12	SIF_IN1 and SIF_IN2	20
ESD Caution	12	SIF_PGA_REF	20
Pin Configuration and Function Descriptions	13	ISET	20
Typical Performance Characteristics	16	Functional Descriptions	21
Terminology	18	SIF Processor	21
Pin Functions	19	Master Clock Oscillator	21
SDIN0, SDIN1, SDIN2, and SDIN3/SPDIF_IN0	19	I ² C Interface	22
LRCLK0, BCLK0, LRCLK1, BCLK1, LRCLK2, and BCLK2	19	ADC Inputs	22
SDO0/AD0	19	I ² S Digital Audio Inputs	22
SPDIF_OUT (SDO1)	19	DAC Voltage Outputs	23
MCLKI/XIN	19	PWM Outputs	24
XOUT	19	Headphone Outputs	24
MCLK_OUT	19	I ² S Digital Audio Outputs	24
SDA	19	S/PDIF Input/Output	25
SCL	20	Hardware Mute Control	25
MUTE	20	Audio Processor	25
RESET	20	Graphical Programming Environment	25
AUXIN1L, AUXIN2L, AUXIN1R, and AUXIN2R	20	Application Layer	25
AUXOUT1L, AUXOUT2L, AUXOUT3L, AUXOUT4L, AUXOUT1R, AUXOUT2R, AUXOUT3R, and AUXOUT4R	20	Loading a Custom Audio Processing Flow	26
HPOUT1L, HPOUT2L, HPOUT1R, and HPOUT2R	20	Outline Dimensions	28
PLL_LF	20	Ordering Guide	28

REVISION HISTORY

7/09—Rev. A to Rev. B

Added Advantiv Logo	1
Change to PWM Outputs Section	24

Change to Hardware Mute Control, Graphical Programming Environment, and Application Layer Sections	25
Changes to Ordering Guide	28

11/08—Revision A: Initial Version

FUNCTIONAL BLOCK DIAGRAM

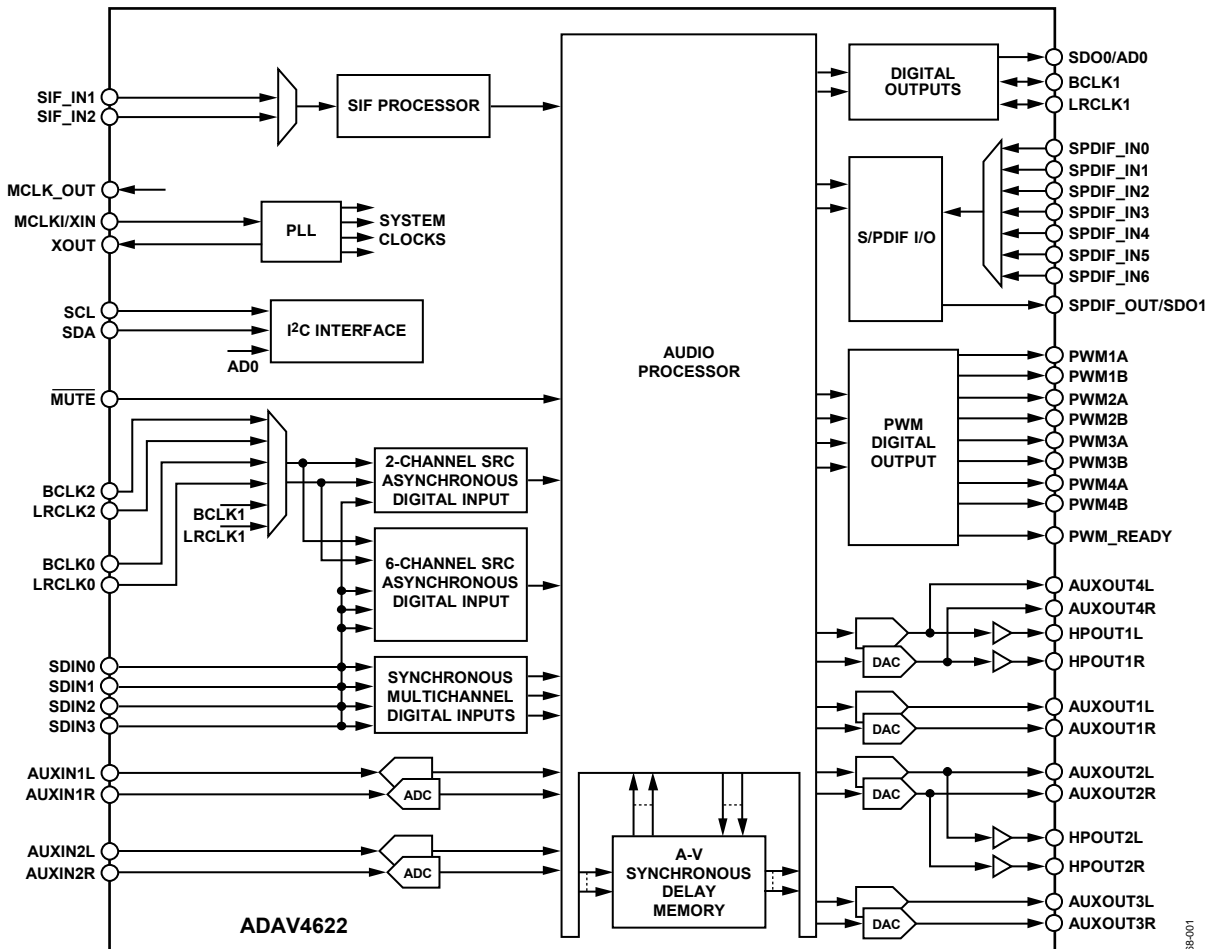

Figure 1. ADAV4622 with PWM-Based Speaker Outputs

07058-001

SPECIFICATIONS

AVDD = 3.3 V, DVDD = 1.8 V, ODVDD = 3.3 V, operating temperature = -40°C to +85°C, master clock = 24.576 MHz, measurement bandwidth = 20 Hz to 20 kHz, ADC input signal = DAC output signal = 1 kHz, unless otherwise noted.

PERFORMANCE PARAMETERS

Table 1.

Parameter	Min	Typ	Max	Unit	Test Conditions/Comments
SIF ADC INPUT SECTION					
Analog Input Frequency Range			10	MHz	
Recommended Analog Input Level		90 ± 18 dB		dBu	FM, AGC in PGA priority mode
Maximum Analog Input Range		1.6		V p-p	Default setting
Input Impedance		12		kΩ	PGA Gain = 0 dB
		6		kΩ	PGA Gain = 10 dB
		2.3		kΩ	PGA Gain = 20 dB
DC Bias Level		1.9		V	
SIF Input Isolation		60		dB	SIF_IN1 to SIF_IN2
FM Limiting Sensitivity		32		dBu	A2 (DK), Mono, deviation mode = 100%, f _{FM} = 400 Hz, Δf = 50 kHz, BW = 20 Hz to 15 kHz, rms detector
		31		dBu	A2 (I), Mono, deviation mode = 100%, f _{FM} = 400 Hz, Δf = 50 kHz, BW = 20 Hz to 15 kHz, rms detector
		31		dBu	A2 (BG), Mono, deviation mode = 100%, f _{FM} = 400 Hz, Δf = 50 kHz, BW = 20 Hz to 15 kHz, rms detector
		34		dBu	BTSC (M, N), Mono, deviation mode = 100%, f _{FM} = 400 Hz, Δf = 25 kHz, BW = 20 Hz to 15 kHz, rms detector
		28.5		dBu	A2 (M), Mono, deviation mode = 100%, f _{FM} = 400 Hz, Δf = 25 kHz, BW = 20 Hz to 15 kHz, rms detector
		30		dBu	EIAJ (M), Mono, deviation mode = 100%, f _{FM} = 400 Hz, Δf = 25 kHz, BW = 20 Hz to 15 kHz, rms detector
FM Output Level at 25% Deviation Mode		53.7		% FS	A2 (DK, I, BG), Mono, V _{SIF} = 100 mV, f _{FM} = 400 Hz, Δf = 12.5 kHz, rms detector
		53.6		% FS	BTSC (M, N), Mono, V _{SIF} = 100 mV, f _{FM} = 400 Hz, Δf = 6.25 kHz, rms detector
		56.3		% FS	A2 (M), Mono, V _{SIF} = 100 mV, f _{FM} = 400 Hz, Δf = 6.25 kHz, rms detector
		56.7		% FS	EIAJ (M), Mono, V _{SIF} = 100 mV, f _{FM} = 400 Hz, Δf = 6.25 kHz, rms detector
FM Output Level at 50% Deviation Mode		53.7		% FS	A2 (DK, I, BG), Mono, V _{SIF} = 100 mV, f _{FM} = 400 Hz, Δf = 25 kHz, rms detector
		53.6		% FS	BTSC (M, N), Mono, V _{SIF} = 100 mV, f _{FM} = 400 Hz, Δf = 12.5 kHz, rms detector
		56.3		% FS	A2 (M), Mono, V _{SIF} = 100 mV, f _{FM} = 400 Hz, Δf = 12.5 kHz, rms detector
		56.7		% FS	EIAJ (M), Mono, V _{SIF} = 100 mV, f _{FM} = 400 Hz, Δf = 12.5 kHz, rms detector
FM Output Level at 100% Deviation Mode		53.7		% FS	A2 (DK, I, BG), Mono, V _{SIF} = 100 mV, f _{FM} = 400 Hz, Δf = 50 kHz, rms detector
		53.6		% FS	BTSC (M, N), Mono, V _{SIF} = 100 mV, f _{FM} = 400 Hz, Δf = 25 kHz, rms detector
		56.3		% FS	A2 (M), Mono, V _{SIF} = 100 mV, f _{FM} = 400 Hz, Δf = 25 kHz, rms detector
		56.7		% FS	EIAJ (M), Mono, V _{SIF} = 100 mV, f _{FM} = 400 Hz, Δf = 25 kHz, rms detector
FM Output Level at 200% Deviation Mode		53.7		% FS	A2 (DK, I, BG), Mono, V _{SIF} = 100 mV, f _{FM} = 400 Hz, Δf = 100 kHz, rms detector
		53.6		% FS	BTSC (M, N), Mono, V _{SIF} = 100 mV, f _{FM} = 400 Hz, Δf = 50 kHz, rms detector
		56.3		% FS	A2 (M), Mono, V _{SIF} = 100 mV, f _{FM} = 400 Hz, Δf = 50 kHz, rms detector
		56.7		% FS	EIAJ (M), Mono, V _{SIF} = 100 mV, f _{FM} = 400 Hz, Δf = 50 kHz, rms detector

Parameter	Min	Typ	Max	Unit	Test Conditions/Comments
FM Output Level at 400% Deviation Mode		53.7		% FS	A2 (DK, I, BG), Mono, $V_{SIF} = 100$ mV, $f_{FM} = 400$ Hz, $\Delta f = 200$ kHz, rms detector
		53.6		% FS	BTSC (M, N), Mono, $V_{SIF} = 100$ mV, $f_{FM} = 400$ Hz, $\Delta f = 100$ kHz, rms detector
		56.4		% FS	A2 (M), Mono, $V_{SIF} = 100$ mV, $f_{FM} = 400$ Hz, $\Delta f = 100$ kHz, rms detector
		56.7		% FS	EIAJ (M), Mono, $V_{SIF} = 100$ mV, $f_{FM} = 400$ Hz, $\Delta f = 100$ kHz, rms detector
FM Output Level at 800% Deviation Mode		53.7		% FS	A2 (DK, I, BG), Mono, $V_{SIF} = 100$ mV, $f_{FM} = 400$ Hz, $\Delta f = 400$ kHz, rms detector
		53.6		% FS	BTSC (M, N), Mono, $V_{SIF} = 100$ mV, $f_{FM} = 400$ Hz, $\Delta f = 200$ kHz, rms detector
		56.3		% FS	A2 (M), Mono, $V_{SIF} = 100$ mV, $f_{FM} = 400$ Hz, $\Delta f = 200$ kHz, rms detector
		56.7		% FS	EIAJ (M), Mono, $V_{SIF} = 100$ mV, $f_{FM} = 400$ Hz, $\Delta f = 200$ kHz, rms detector
AM Rejection Ratio		69.5		dB	A2 (DK), Mono, deviation mode = 100%, $V_{SIF} = 100$ mV, $f_{FM} = 400$ Hz, $\Delta f = 27$ kHz, $f_{AM} = 400$ Hz, $MOD_{AM} = 30\%$, $BW = 20$ Hz to 15 kHz, rms detector
		70		dB	A2 (I), Mono, deviation mode = 100%, $V_{SIF} = 100$ mV, $f_{FM} = 400$ Hz, $\Delta f = 27$ kHz, $f_{AM} = 400$ Hz, $MOD_{AM} = 30\%$, $BW = 20$ Hz to 15 kHz, rms detector
		70		dB	A2 (BG), Mono, deviation mode = 100%, $V_{SIF} = 100$ mV, $f_{FM} = 400$ Hz, $\Delta f = 27$ kHz, $f_{AM} = 400$ Hz, $MOD_{AM} = 30\%$, $BW = 20$ Hz to 15 kHz, rms detector
		70.5		dB	Mono (M), deviation mode = 100%, $V_{SIF} = 100$ mV, $f_{FM} = 400$ Hz, $\Delta f = 13.5$ kHz, $f_{AM} = 400$ Hz, $MOD_{AM} = 30\%$, $BW = 20$ Hz to 15 kHz, rms detector
AM Sensitivity		40		dBu	Mono (L), $f_{AM} = 400$ Hz, $MOD = 30\%$, $BW = 20$ Hz to 15 kHz, rms detector, $(S + N)/N = 10$ dB
BTSC (M) PERFORMANCE					
Measured at analog audio output, video = 75% color bar, $f_{SC} = 4.5$ MHz, $f_{FM} = 1$ kHz, $\Delta f = 25$ kHz (100%), deemphasis = 75 μ s, measuring $BW = 20$ Hz to 15 kHz with dBX NR					
Dynamic Range					
Stereo Channel		62		dB	Stereo L or R (L = -R), 100%, 1 kHz
SAP Channel		68		dB	SAP channel with Mono 100%, 1 kHz
Total Harmonic Distortion + Noise					
Stereo Channel		-46		dB	Stereo L or R (L = -R), 100%, 1 kHz
SAP Channel		-40		dB	SAP 100%, 1 kHz
Frequency Response					$f_{FM} = 20$ Hz to 12 kHz
Stereo Channel			+0.1/-0.7	dB	Stereo L or R, 50%, (L = -R)
SAP Channel			+2.5/-2.5	dB	SAP 50%, Mono 100%, 1 kHz
Crosstalk					
Stereo-to-SAP Channel		-74		dB	L or R 50%, 1 kHz
SAP-to-Stereo Channel		-71		dB	SAP 50%, 1 kHz
Stereo Separation dBX		30		dB	L off, R 50%, 1 kHz
EIAJ (M) PERFORMANCE					
Measured at analog audio output, video = 75% color bar, $f_{SC} = 4.5$ MHz, $f_{FM} = 1$ kHz, $\Delta f = 25$ kHz (100%), deemphasis = 75 μ s, measuring $BW = 20$ Hz to 15 kHz					
Dynamic Range					
Stereo Channel		58		dB	Stereo L or R, 100%, 1 kHz
Dual Channel		56		dB	Dual channel with Mono 100%, 1 kHz
Total Harmonic Distortion + Noise					
Stereo Channel		-56		dB	Stereo L or R, 100%, 1 kHz
Dual Channel		-47		dB	Dual 50%, 1 kHz
Frequency Response					$f_{FM} = 20$ Hz to 10 kHz
Stereo Channel			+0.03/-0.53	dB	Stereo L or R, 100%
Dual Channel			+0.17/-1.4	dB	Dual 100%, Mono 100%, 1 kHz
Crosstalk					
Main-to-Dual Channel		-75		dB	Main 100%, 1 kHz
Dual-to-Main Channel		-83		dB	Dual 100%, 1 kHz
Stereo Separation		39		dB	Stereo L or R, 100%, 1 kHz

ADAV4622

Parameter	Min	Typ	Max	Unit	Test Conditions/Comments
A2 (M) PERFORMANCE					
Dynamic Range		60		dB	Measured at analog audio output, video = 75% color bar, $f_{SC1} = 4.5$ MHz, $f_{SC2} = 4.724$ MHz, $f_{FM} = 1$ kHz, $\Delta f = 25$ kHz (100%), deemphasis = 75 μ s, measuring BW = 20 Hz to 15 kHz
Total Harmonic Distortion + Noise		-64		dB	Mono 100%, 1 kHz
Frequency Response			+0.4/-0.05	dB	Mono 100%, 1 kHz
Crosstalk (Dual)		-88		dB	Mono or dual off, 100%, 1 kHz
Channel Separation (Stereo)		66		dB	Stereo L off, R 50%, 1 kHz
A2 (DK1/DK2/DK3) PERFORMANCE					
Dynamic Range		74		dB	Measured at analog audio output, video = 75% color bar, $f_{SC1} = 6.5$ MHz, $f_{SC2} = 6.742$ MHz, (DK2 worst case), $f_{FM} = 1$ kHz, $\Delta f = 50$ kHz (100%), deemphasis = 50 μ s, measuring BW = 20 Hz to 15 kHz
Total Harmonic Distortion + Noise		-66		dB	Mono 100%, 1 kHz
Frequency Response			+0.1/-0.3	dB	Mono 100%, $f_{FM} = 20$ Hz to 15 kHz
Crosstalk (Dual)		-88		dB	Mono or dual off, 100%, 1 kHz
Channel Separation (Stereo)		77		dB	Stereo L off, R 50%, 1 kHz
A2 (BG) PERFORMANCE					
Dynamic Range		74		dB	Measured at analog audio output, video = 75% color bar, $f_{SC1} = 5.5$ MHz, $f_{SC2} = 5.742$ MHz, $f_{FM} = 1$ kHz, $\Delta f = 50$ kHz (100%), deemphasis = 50 μ s, measuring BW = 20 Hz to 15 kHz
Total Harmonic Distortion + Noise		-61		dB	Mono 100%, 1 kHz
Frequency Response			+0.1/-0.3	dB	Mono 100%, $f_{FM} = 25$ Hz to 15 kHz
Crosstalk (Dual)		-89		dB	Mono or dual off, 100%, 1 kHz
Channel Separation (Stereo)		70		dB	Stereo L off, R 50%, 1 kHz
NICAM (I) PERFORMANCE					
Dynamic Range		72		dB	Measured at analog audio output, video = 75% color bar, 1 kHz, unweighted, deemphasis = J17, measuring BW = 20 Hz to 15 kHz
Total Harmonic Distortion + Noise		-63		dB	Stereo L or R, 0 dB, 1 kHz
Frequency Response			-1.3/+0.07	dB	Stereo L or R, 0 dB, 1 kHz
Crosstalk		-80		dB	Stereo L or R, 0 dB
Stereo Separation		73		dB	Mono or dual, 0 dB, 1 kHz
Bit Error Rate		0		dB	L or R, 0 dB, 1 kHz
NICAM (BG, DK, L) PERFORMANCE					
Dynamic Range		72		dB	Measured at analog audio output, video = 75% color bar, 1 kHz, unweighted, deemphasis = J17, measuring BW = 20 Hz to 15 kHz
Total Harmonic Distortion + Noise		-63		dB	Stereo L or R, 0 dB, 1 kHz
Frequency Response			-1.3/+0.07	dB	Stereo L or R, 0 dB
Crosstalk		-80		dB	Mono or dual, 0 dB, 1 kHz
Stereo Separation		74		dB	L or R, 0 dB, 1 kHz
Bit Error Rate		0		dB	FM and NICAM nominal conditions
AM PERFORMANCE					
Dynamic Range					Measured at analog audio output, 1 kHz, AM carrier 6.5 MHz measuring BW = 20 Hz to 15 kHz
RMS/FLAT		55		dB	AM = 54% modulation
QP/CCIR		35		dB	CCIR filter, AM = 54% modulation
Total Harmonic Distortion + Noise		-49		dB	AM = 54% modulation
Frequency Response			+0.03/-1.2	dB	AM = 54% modulation
REFERENCE SECTION					
Absolute Voltage V_{REF}		1.53		V	
V_{REF} Temperature Coefficient		100		ppm/ $^{\circ}$ C	

Parameter	Min	Typ	Max	Unit	Test Conditions/Comments
ADC SECTION					
Number of Channels		4			Two stereo channels
Full-Scale Input Level		100		μA rms	
Resolution		24		Bits	
Dynamic Range (Stereo Channel)					
A-Weighted		95		dB	–60 dBFS with respect to full-scale analog input
Total Harmonic Distortion + Noise (Stereo Channel)		–90		dB	–3 dBFS with respect to full-scale analog input
Gain Mismatch		0.2		dB	Left- and right-channel gain mismatch
Crosstalk (Left to Right, Right to Left)		–110		dB	
Gain Error		–1		dB	Input signal is 100 μA rms
Current Setting Resistor (R _{ISER})		20		kΩ	External resistor to set current input range of ADC for nominal 2.0 V rms input signal
Power Supply Rejection		–87		dB	1 kHz, 300 mV p-p signal at AVDD
ADC DIGITAL DECIMATOR FILTER CHARACTERISTICS					
Pass Band		22.5		kHz	At 48 kHz, guaranteed by design
Pass-Band Ripple		±0.0002		dB	
Stop Band		26.5		kHz	
Stop-Band Attenuation		100		dB	
Group Delay		1040		μs	
PWM SECTION					
Frequency		384		kHz	Guaranteed by design
Modulation Index		0.976			Guaranteed by design
Dynamic Range					
A-Weighted		98		dB	–60 dB with respect to full-scale code input
Total Harmonic Distortion + Noise		–78		dB	–3 dB with respect to full-scale code input
DAC SECTION					
Number of Auxiliary Output Channels		8			Four stereo channels
Resolution		24		Bits	
Full-Scale Analog Output		1		V rms	
Dynamic Range					
A-Weighted		94		dB	–60 dBFS with respect to full-scale code input
Total Harmonic Distortion + Noise		–86		dB	–3 dBFS with respect to full-scale code input
Crosstalk (Left to Right, Right to Left)		–102		dB	
Interchannel Gain Mismatch		0.1		dB	Left- and right-channel gain mismatch
Gain Error		0.525		dB	1 V rms output
DC Bias		1.53		V	
Power Supply Rejection		–90		dB	1 kHz, 300 mV p-p signal at AVDD
Output Impedance		235		Ω	
DAC DIGITAL INTERPOLATION FILTER CHARACTERISTICS					
Pass Band		21.769		kHz	At 48 kHz, guaranteed by design
Pass-Band Ripple		±0.01		dB	
Transition Band		23.95		kHz	
Stop Band		26.122		kHz	
Stop-Band Attenuation		75		dB	
Group Delay		580		μs	
HEADPHONE AMPLIFIER					
Number of Channels		4			Measured at headphone output with 32 Ω load
Full-Scale Output Power		31		mW rms	Two stereo channels
Dynamic Range					1 V rms output
A-Weighted		93		dB	–60 dBFS with respect to full-scale code input
Total Harmonic Distortion + Noise		–83		dB	–3 dBFS with respect to full-scale code input
Interchannel Gain Mismatch		0.1		dB	
DC Bias		1.53		V	
Power Supply Rejection		–85		dB	1 kHz, 300 mV p-p signal at AVDD

ADAV4622

Parameter	Min	Typ	Max	Unit	Test Conditions/Comments
SRC					
Number of Channels		8			Two channels (SRC1), six channels (SRC2)
Dynamic Range					
A-Weighted		115		dB	–60 dBFS input (worst-case input $f_s = 50$ kHz)
Total Harmonic Distortion + Noise		–113		dB	–3 dBFS input (worst-case input $f_s = 50$ kHz)
Sample Rate	5		50	kHz	
SRC DIGITAL INTERPOLATION FILTER CHARACTERISTICS					
Pass Band		21.678		kHz	At 48 kHz, guaranteed by design
Pass-Band Ripple		0.005		dB	
Stop Band		26.232		kHz	
Stop-Band Attenuation		110		dB	
Group Delay		876		μ s	
DIGITAL INPUT/OUTPUT					
Input Voltage High (V_{IH})	2.0		ODVDD	V	$V_{IH} = ODVDD$, equivalent to a 90 k Ω pull-up resistor $V_{IH} = ODVDD$, equivalent to a 266 k Ω pull-up resistor $V_{IL} = 0$ V, equivalent to a 90 k Ω pull-down resistor $I_{OH} = 0.4$ mA $I_{OL} = -2$ mA $I_{OH} = 0.4$ mA $I_{OL} = -3.2$ mA
Input Voltage Low (V_{IL})			0.8	V	
Input Leakage					
I_{IH} (SDIN0, SDIN1, SDIN2, SDIN3, LRCLK0, LRCLK1, LRCLK2, BCLK0, BCLK1, BCLK2, SPDIF_OUT, SPDIF_IN)		40		μ A	
I_{IH} (\overline{RESET})		13.5		μ A	
I_{IL} (SDO0, SCL, SDA)		–40		μ A	
Output Voltage High (V_{OH})	2.4			V	
Output Voltage Low (V_{OL})			0.4	V	
Output Voltage High (V_{OH}) (MCLK_OUT)	1.4			V	
Output Voltage Low (V_{OL}) (MCLK_OUT)			0.4	V	
Input Capacitance		10		pF	
SUPPLIES					
Analog Supplies (AVDD)	3.0	3.3	3.6	V	MCLK = 24 MHz, ADCs and DACs active, headphone outputs active and driving a 16 Ω load ADC, DAC, and headphone outputs floating, \overline{RESET} low, MCLK = 24 MHz
Digital Supplies (DVDD)	1.65	1.8	2.0	V	
Interface Supply (ODVDD)	3.0	3.3	3.6	V	
Supply Currents					
Analog Current		260		mA	
Digital Current		350		mA	
Interface Current		2		mA	
Power Dissipation		1.495		W	
Standby Currents					
Analog Current		10		mA	
Digital Current		4		mA	
Interface Current		1.6		mA	
TEMPERATURE RANGE					
Operating Temperature	–40		+85	$^{\circ}$ C	
Storage Temperature	–65		+150	$^{\circ}$ C	

TIMING SPECIFICATIONS

Table 2.

Parameter	Description	Min	Max	Unit	Comments
MASTER CLOCK AND RESET					
f _{MCLKI}	MCLKI frequency	3.072	24.576	MHz	
t _{MCH}	MCLKI high	10		ns	
t _{MCL}	MCLKI low	10		ns	
t _{RESET}	RESET low	200		ns	
MASTER CLOCK OUTPUT					
t _{JIT}	Period jitter		800	ps	
t _{CH}	MCLK_OUT high	45	55	%	
t _{CL}	MCLK_OUT low	45	55	%	
I²C PORT					
f _{SCL}	SCL clock frequency		400	kHz	
t _{SCLH}	SCL high	600		ns	
t _{SCLL}	SCL low	1.3		μs	
Start Condition					
t _{SCS}	Setup time	600		ns	Relevant for repeated start condition After this period, the first clock is generated
t _{SCH}	Hold time	600		ns	
t _{DS}	Data setup time	100		ns	
t _{SCR}	SCL rise time		300	ns	
t _{SCF}	SCL fall time		300	ns	
t _{SDR}	SDA rise time		300	ns	
t _{SDF}	SDA fall time		300	ns	
Stop Condition					
t _{SCS}	Setup time	0		ns	
SERIAL PORTS					
Slave Mode					
t _{SBH}	BCLK high	40		ns	
t _{SBL}	BCLK low	40		ns	
f _{SBF}	BCLK frequency	64 × f _S			
t _{SLS}	LRCLK setup	10		ns	To BCLK rising edge
t _{SLH}	LRCLK hold	10		ns	From BCLK rising edge
t _{SDS}	SDIN setup	10		ns	To BCLK rising edge
t _{SDH}	SDIN hold	10		ns	From BCLK rising edge
t _{SDD}	SDO delay		50	ns	From BCLK falling edge
Master Mode					
t _{MLD}	LRCLK delay		25	ns	From BCLK falling edge
t _{MDD}	SDO delay		15	ns	From BCLK falling edge
t _{MDS}	SDIN setup	10		ns	From BCLK rising edge
t _{MDH}	SDIN hold	10		ns	From BCLK rising edge

TIMING DIAGRAMS

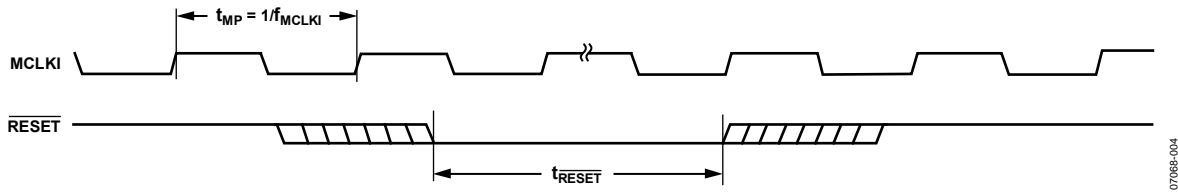

Figure 2. Master Clock and Reset Timing

070668-004

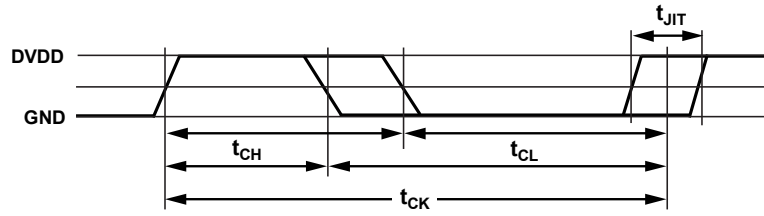

Figure 3. Master Clock Output Timing

070668-036

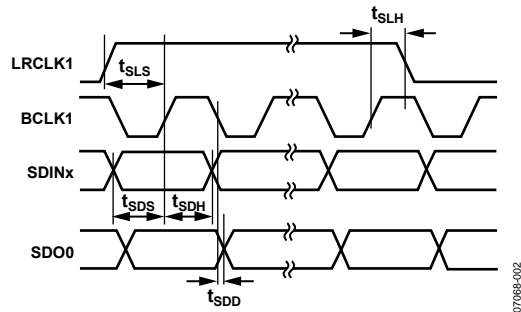

Figure 4. Serial Port Slave Mode Timing

070668-002

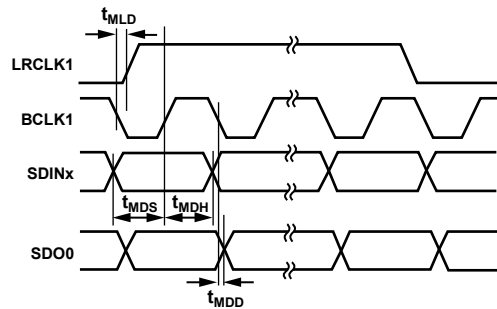

Figure 5. Serial Port Master Mode Timing

070668-003

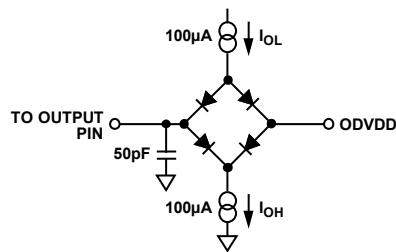

Figure 6. Load Circuit for Digital Output Timing Specifications

070668-033

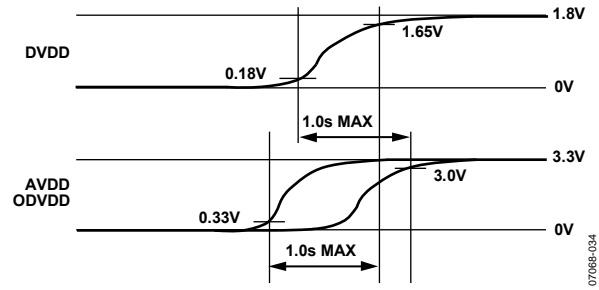

Figure 7. Power-Up Sequence Timing

0706B-034

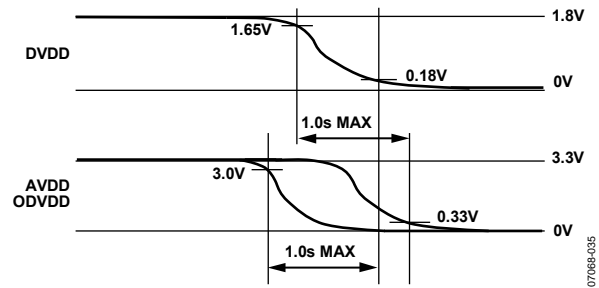

Figure 8. Power-Down Sequence Timing

0706B-035

ABSOLUTE MAXIMUM RATINGS

Table 3.

Parameter	Rating
DVDD to DGND	0 V to 2.2 V
ODVDD to DGND	0 V to 4 V
AVDD to AGND	0 V to 4 V
AGND to DGND	-0.3 V to +0.3 V
Digital Inputs	DGND - 0.3 V to ODVDD + 0.3 V
Analog Inputs	AGND - 0.3 V to AVDD + 0.3 V
Reference Voltage	Indefinite short circuit to ground
Soldering (10 sec)	300°C

Stresses above those listed under Absolute Maximum Ratings may cause permanent damage to the device. This is a stress rating only; functional operation of the device at these or any other conditions above those indicated in the operational section of this specification is not implied. Exposure to absolute maximum rating conditions for extended periods may affect device reliability.

THERMAL RESISTANCE

θ_{JA} is specified for the worst-case conditions, that is, a device soldered in a circuit board for surface-mount packages.

Table 4. Thermal Resistance¹

Package Type	θ_{JA}	θ_{JC}	Unit
80-Lead LQFP	38.1	7.6	°C/W

¹ Based on JEDEC 2S2P PCB.

THERMAL CONDITIONS

To ensure correct operation of the device, the case temperature (T_{CASE}) must be kept below 121°C to keep the junction temperature (T_J) below the maximum allowed, 125°C.

ESD CAUTION



ESD (electrostatic discharge) sensitive device. Charged devices and circuit boards can discharge without detection. Although this product features patented or proprietary protection circuitry, damage may occur on devices subjected to high energy ESD. Therefore, proper ESD precautions should be taken to avoid performance degradation or loss of functionality.

PIN CONFIGURATION AND FUNCTION DESCRIPTIONS

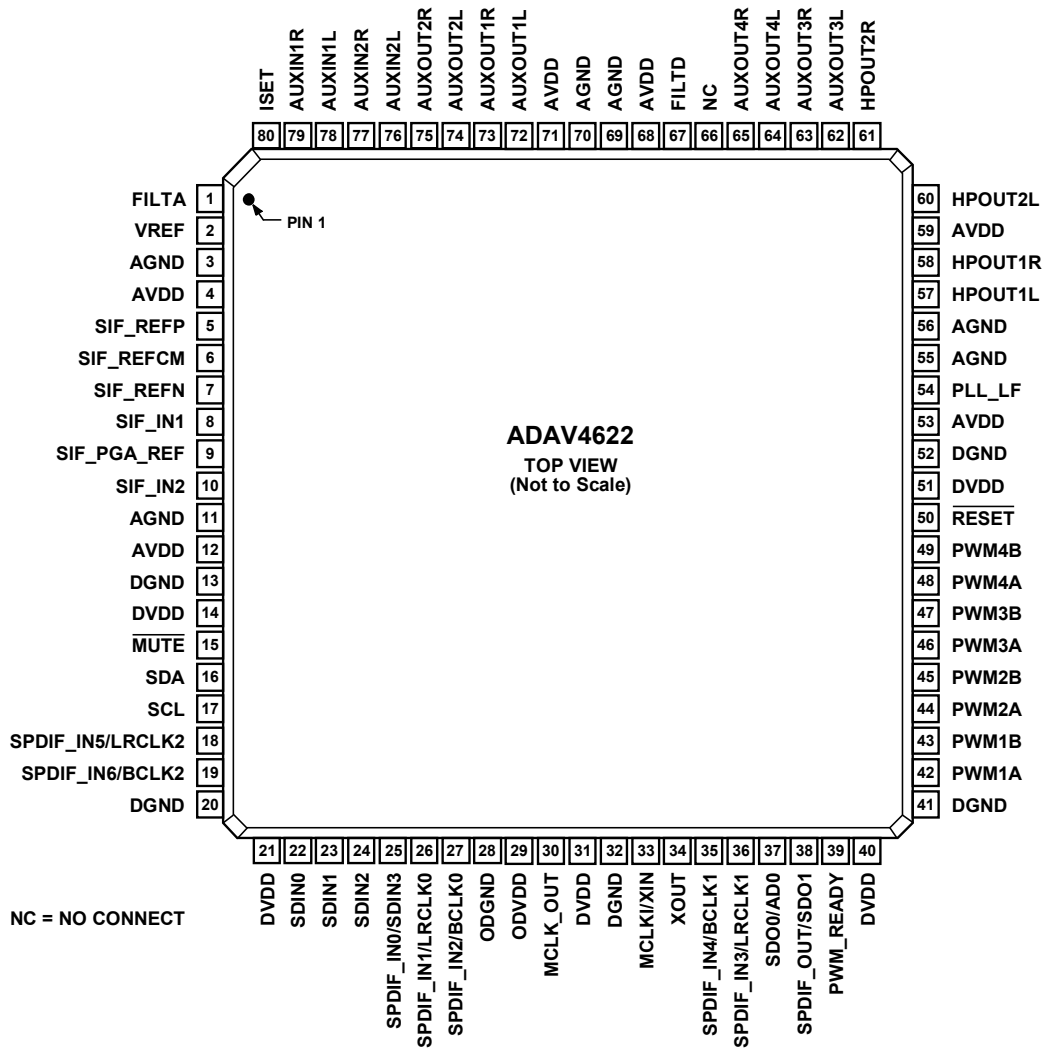

Figure 9. Pin Configuration

07068-006

Table 5. Pin Function Descriptions

Pin No.	Mnemonic	Description
1	FILTA	ADC Filter Capacitor.
2	VREF	Reference Capacitor.
3	AGND	ADC Ground.
4	AVDD	ADC Supply (3.3 V).
5	SIF_REFP	SIF ADC Positive Reference (Typical 1.4 V).
6	SIF_REFCM	SIF ADC Common-Mode Reference (Typical 1 V).
7	SIF_REFN	SIF ADC Negative Reference (Typical 0.6 V).
8	SIF_IN1	SIF Input 1.
9	SIF_PGA_REF	SIF PGA Reference.
10	SIF_IN2	SIF Input 2.
11	AGND	SIF AGND.
12	AVDD	SIF Supply (3.3 V).
13	DGND	Digital Ground.
14	DVDD	Digital Supply (1.8 V).
15	MUTE	Active Low Mute Request Input Signal.

ADAV4622

Pin No.	Mnemonic	Description
16	SDA	I ² C Data.
17	SCL	I ² C Clock.
18	SPDIF_IN5/LRCLK2	External Input to S/PDIF Mux/Left/Right Clock for SRC2 (Default).
19	SPDIF_IN6/BCLK2	External Input to S/PDIF Mux/Bit Clock for SRC2 (Default).
20	DGND	Digital Ground.
21	DVDD	Digital Supply (1.8 V).
22	SDINO	Serial Data Input 0/SRC Data Input.
23	SDIN1	Serial Data Input 1/SRC Data Input.
24	SDIN2	Serial Data Input 2/SRC Data Input.
25	SPDIF_IN0/SDIN3	External Input to S/PDIF Mux/SRC Data Input/Serial Data Input 3 (Default).
26	SPDIF_IN1/LRCLK0	External Input to S/PDIF Mux/Left/Right Clock for SRC1 (Default).
27	SPDIF_IN2/BCLK0	External Input to S/PDIF Mux/Bit Clock for SRC1 (Default).
28	ODGND	Digital Ground.
29	ODVDD	Digital Interface Supply (3.3 V).
30	MCLK_OUT	Master Clock Output.
31	DVDD	Digital Supply (1.8 V).
32	DGND	Digital Ground.
33	MCLKI/XIN	Master Clock/Crystal Input.
34	XOUT	Crystal Output.
35	SPDIF_IN4/BCLK1	External Input to S/PDIF Mux/Bit Clock for Serial Data I/O (Default).
36	SPDIF_IN3/LRCLK1	External Input to S/PDIF Mux/Left/Right Clock for Serial Data I/O (Default).
37	SDO0/AD0	Serial Data Output. This pin acts as the I ² C address select on reset. It has an internal pull-down resistor.
38	SPDIF_OUT/SDO1	Output of S/PDIF Mux/Serial Data Output.
39	PWM_READY	PWM Ready Flag.
40	DVDD	Digital Supply (1.8 V).
41	DGND	Digital Ground.
42	PWM1A	Pulse-Width Modulated Output 1A.
43	PWM1B	Pulse-Width Modulated Output 1B.
44	PWM2A	Pulse-Width Modulated Output 2A.
45	PWM2B	Pulse-Width Modulated Output 2B.
46	PWM3A	Pulse-Width Modulated Output 3A.
47	PWM3B	Pulse-Width Modulated Output 3B.
48	PWM4A	Pulse-Width Modulated Output 4A.
49	PWM4B	Pulse-Width Modulated Output 4B.
50	$\overline{\text{RESET}}$	Reset Analog and Digital Cores.
51	DVDD	Digital Supply (1.8 V).
52	DGND	Digital Ground.
53	AVDD	PLL Supply (3.3 V).
54	PLL_LF	PLL Loop Filter.
55	AGND	PLL Ground.
56	AGND	Headphone Driver Ground.
57	HPOUT1L	Left Headphone Output 1.
58	HPOUT1R	Right Headphone Output 1.
59	AVDD	Headphone Driver Supply (3.3 V).
60	HPOUT2L	Left Headphone Output 2.
61	HPOUT2R	Right Headphone Output 2.
62	AUXOUT3L	Left Auxiliary Output 3.
63	AUXOUT3R	Right Auxiliary Output 3.
64	AUXOUT4L	Left Auxiliary Output 4.
65	AUXOUT4R	Right Auxiliary Output 4.
66	NC	No Connection to this Pin Allowed.
67	FILTD	DAC Filter Capacitor.

Pin No.	Mnemonic	Description
68	AVDD	DAC Supply (3.3 V).
69	AGND	DAC Ground.
70	AGND	DAC Ground.
71	AVDD	DAC Supply (3.3 V).
72	AUXOUT1L	Left Auxiliary Output 1.
73	AUXOUT1R	Right Auxiliary Output 1.
74	AUXOUT2L	Left Auxiliary Output 2.
75	AUXOUT2R	Right Auxiliary Output 2.
76	AUXIN2L	Left Auxiliary Input 2.
77	AUXIN2R	Right Auxiliary Input 2.
78	AUXIN1L	Left Auxiliary Input 1.
79	AUXIN1R	Right Auxiliary Input 1.
80	ISET	ADC Current Setting.

TYPICAL PERFORMANCE CHARACTERISTICS



Figure 10. DAC Composite Filter Response (48 kHz)

0706E-007

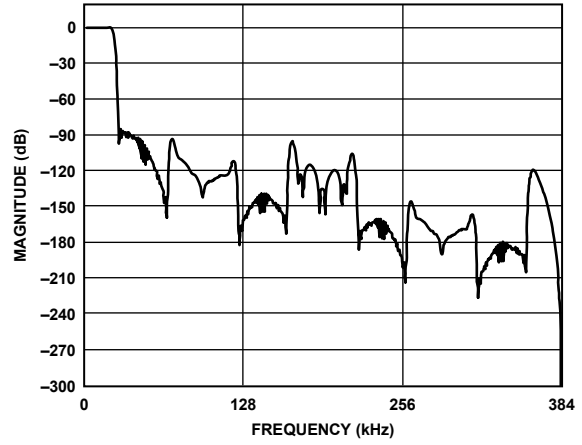

Figure 13. ADC Composite Filter Response (48 kHz)

0706E-010

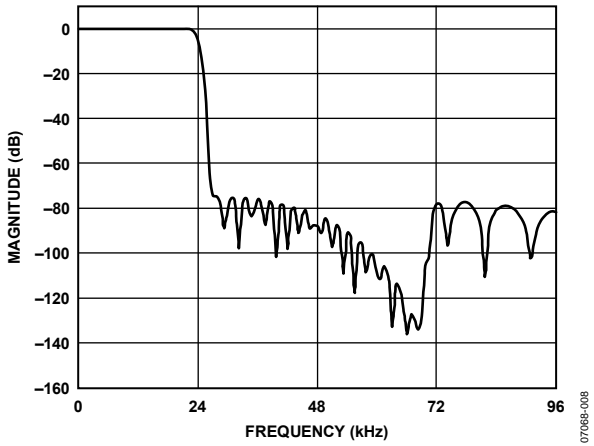

Figure 11. DAC Band-Pass Filter Response (48 kHz)

0706E-008

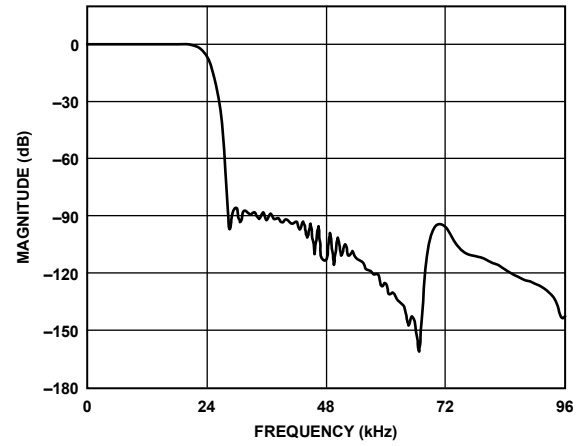

Figure 14. ADC Band-Pass Filter Response (48 kHz)

0706E-011

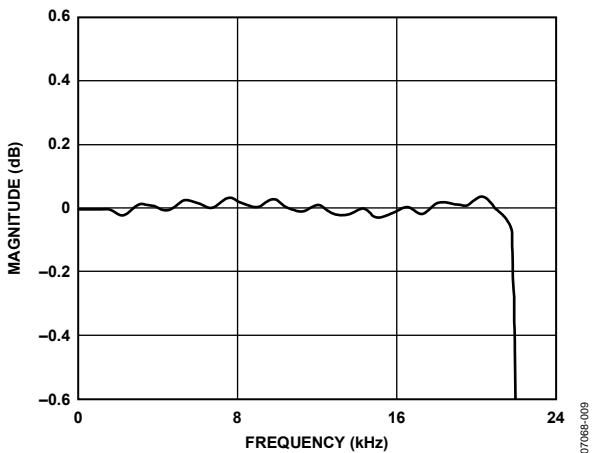

Figure 12. DAC Pass-Band Ripple (48 kHz)

0706E-009

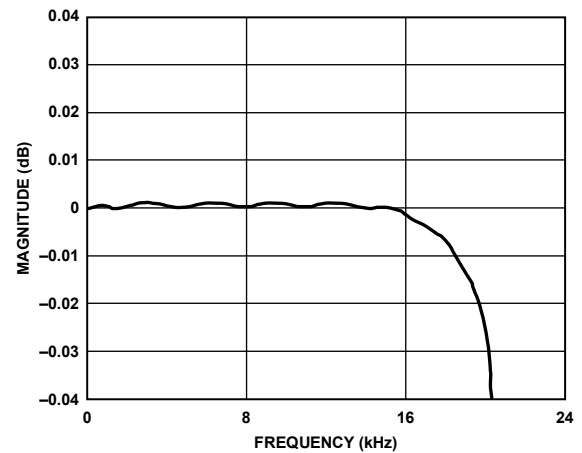

Figure 15. ADC Pass-Band Ripple (48 kHz)

0706E-012

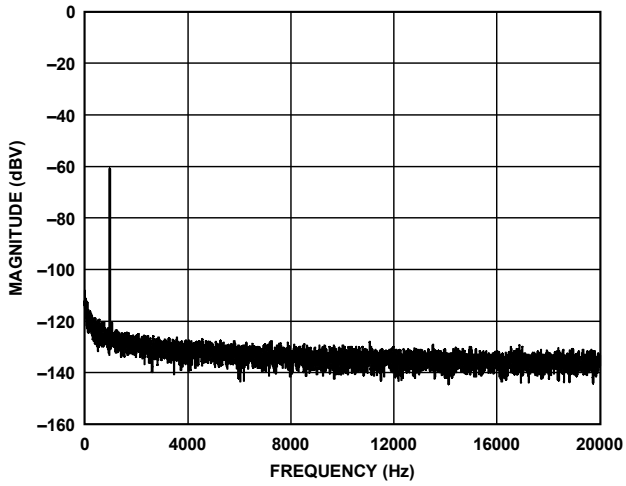

Figure 16. DAC Dynamic Range

07068B-013

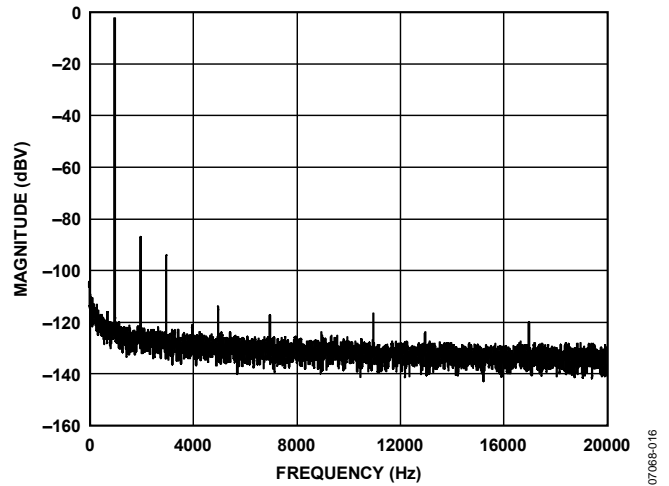

Figure 19. ADC Total Harmonic Distortion + Noise

07068B-016

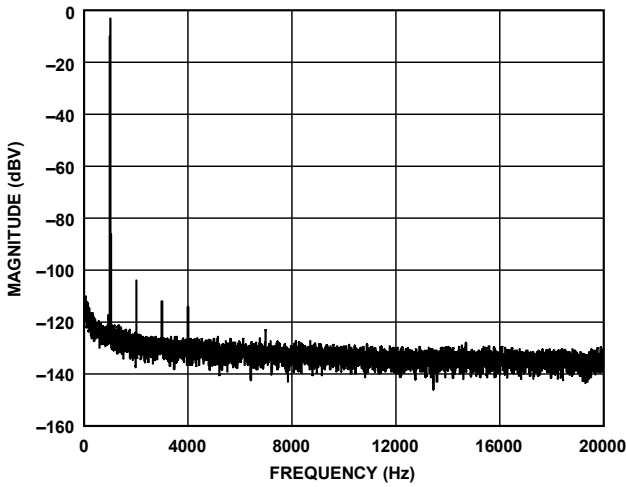

Figure 17. DAC Total Harmonic Distortion + Noise

07068B-014

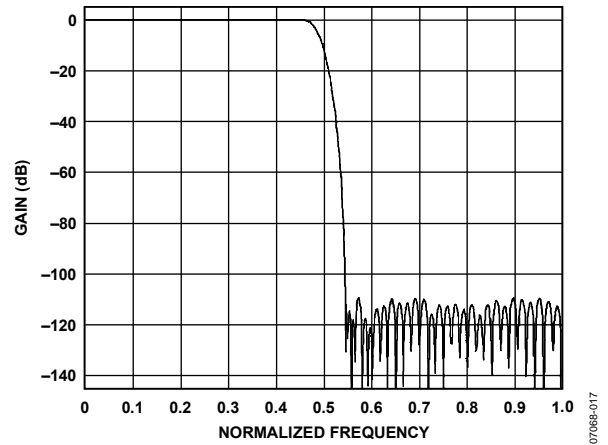

Figure 20. Sample Rate Converter Transfer Function

07068B-017

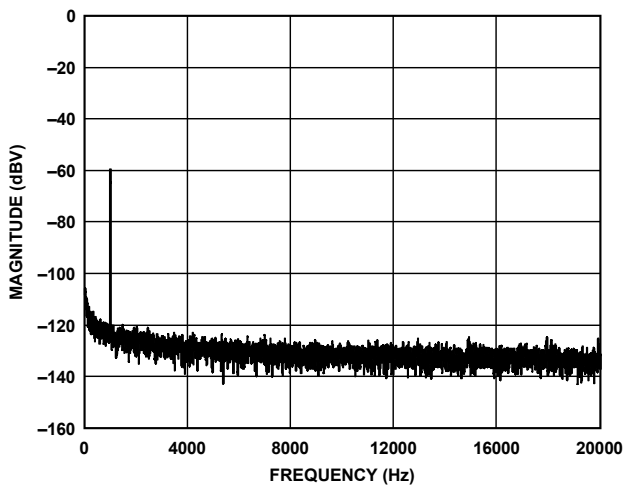

Figure 18. ADC Dynamic Range

07068B-015

TERMINOLOGY

Dynamic Range

The ratio of a full-scale input signal to the integrated input noise in the pass band (20 Hz to 20 kHz), expressed in decibels (dB). Dynamic range is measured with a -60 dB input signal and is equal to $(S/[THD+N]) + 60$ dB. Note that spurious harmonics are below the noise with a -60 dB input, so the noise level establishes the dynamic range. The dynamic range is specified with and without an A-weight filter applied.

Pass Band

The region of the frequency spectrum unaffected by the attenuation of the digital decimator's filter.

Pass-Band Ripple

The peak-to-peak variation in amplitude response from equal amplitude input signal frequencies within the pass band, expressed in decibels.

Stop Band

The region of the frequency spectrum attenuated by the digital decimator's filter to the degree specified by stop-band attenuation.

Gain Error

With a near full-scale input, the ratio of the actual output to the expected output, expressed in dB.

Interchannel Gain Mismatch

With identical near full-scale inputs, the ratio of the outputs of the two stereo channels, expressed in decibels.

Crosstalk

Ratio of response on one channel with a grounded input to a full-scale 1 kHz sine wave input on the other channel, expressed in decibels.

Power Supply Rejection

With no analog input, the signal present at the output when a 300 mV p-p signal is applied to power supply pins, expressed in decibels of full scale.

Group Delay

Intuitively, the time interval required for an input pulse to appear at the converter's output, expressed in milliseconds (ms). More precisely, the derivative of radian phase with respect to radian frequency at a given frequency.

SIF Input Isolation

The level of the crosstalk between the SIF inputs in dB.

FM Limiting Sensitivity

FM limiting sensitivity is given by the modulated carrier level that gives half the power to the FM demodulator's output amplitude comparing to that when the carrier level satisfies the demodulator's limiting level.

Deviation Mode

In some regions, the transmitted signal can deviate from the specification. In order for the ADAV4622 to decode these high deviation signals correctly, the appropriate modulation level must be selected.

AM Rejection Ratio

AM rejection ratio is given by the ratio of FM (deviation = 54%) demodulated audio level vs. residual AM (modulation = 27%) demodulated audio level at the same carrier level. It is the ability of the receiver to not mistake an AM signal for an FM signal.

AM Sensitivity

AM sensitivity is a measure of how well the receiver picks up very weak AM signals.

PIN FUNCTIONS

Table 5 shows the pin numbers, mnemonics, and descriptions for the ADAV4622. The input pins have a logic threshold compatible with 3.3 V input levels.

SDIN0, SDIN1, SDIN2, AND SDIN3/SPDIF_IN0

Serial data inputs. These input pins provide the digital audio data to the signal processing core. Any of the inputs can be routed to either of the SRCs for conversion; this input is then not available as a synchronous input to the audio processor but only as an input through the selected SRC. The serial format for the synchronous data is selected by Bits [3:2] of the serial port control register. If the SRCs are required, the serial format is selected by Bits [12:9] of the same register. The synchronous inputs are capable of using any pair of serial clocks LRCLK0/BCLK0, LRCLK1/BCLK1, or LRCLK2/BCLK2. By default, they use LRCLK1 and BCLK1. See Figure 24 for more details regarding the configuration of the synchronous inputs.

SDIN3 is a shared pin with SPDIF_IN0. If SDIN3 is not in use, this pin can be used to connect an S/PDIF signal from an external source, such as an MPEG decoder, to the ADAV4622 on-chip S/PDIF output multiplexer. If SPDIF_OUT is selected from one of the SPDIF_IN (external) signals, the signal is simply passed through from input to output.

LRCLK0, BCLK0, LRCLK1, BCLK1, LRCLK2, AND BCLK2

By default, LRCLK1 and BCLK1 are associated with the synchronous inputs, LRCLK0 and BCLK0 are associated with SRC1, and LRCLK2 and BCLK2 are associated with SRC2. However, the SRCs and synchronous inputs can use any of the serial clocks (see Figure 24 for more details). LRCLK0, BCLK0, LRCLK1, BCLK1, LRCLK2, and BCLK2 are shared pins with SPDIF_IN1, SPDIF_IN2, SPDIF_IN3, SPDIF_IN4, SPDIF_IN5, and SPDIF_IN6, respectively. If LRCLK0/LRCLK1/LRCLK2 or BCLK0/BCLK1/BCLK2 are not in use, these pins can be used to connect an S/PDIF signal from an external source, such as an MPEG decoder, to the ADAV4622 on-chip S/PDIF output multiplexer. If SPDIF_OUT is selected from one of the SPDIF_IN (external) signals, the signal is simply passed through from input to output.

SDO0/AD0

Serial data output. This pin can output two channels of digital audio using a variety of standard 2-channel formats. The clocks for SDO0 are always the same as those used by the synchronous inputs; this means that LRCLK1 and BCLK1 are used by default, although SDO0 is capable of using any pair of serial clocks, LRCLK0/BCLK0, LRCLK1/BCLK1, or LRCLK2/BCLK2.

The serial port control register selects the serial format for the synchronous output. On reset, the SDO0 pin duplicates as the I²C[®] address select pin. In this mode, the logical state of the pin is polled for four MCLKI cycles following reset. The address select bit is set as the majority poll of the pin's logic level after the four MCLKI cycles.

SPDIF_OUT (SDO1)

The ADAV4622 contains an S/PDIF multiplexer functionality that allows the SPDIF_OUT signal to be chosen from an internally generated S/PDIF signal or from the S/PDIF signal from an external source, which is connected via one of the SPDIF_IN pins. This pin can also be configured as an additional serial data output (SDO1) as an alternate function.

MCLKI/XIN

Master clock input. The ADAV4622 uses a PLL to generate the appropriate internal clock for the audio processing core. A clock signal of a suitable frequency can be connected directly to this pin, or a crystal can be connected between MCLKI/XIN and XOUT together with the appropriate capacitors to DGND to generate a suitable clock signal.

XOUT

This pin is used in conjunction with MCLKI/XIN to generate a clock signal for the ADAV4622.

MCLK_OUT

This pin can be used to output MCLKI or one of the internal system clocks. It should be noted that the output level of this pin is referenced to DVDD (1.8 V) and not ODVDD (3.3 V) like all other digital inputs and outputs.

SDA

Serial data input for the I²C control port. SDA features a glitch elimination filter that removes spurious pulses that are less than 50 ns wide.

ADAV4622

SCL

Serial clock for the I²C control port. SCL features a glitch elimination filter that removes spurious pulses that are less than 50 ns wide.

MUTE

Mute input request. This active-low input pin controls the muting of the output ports (both analog and digital) from the ADAV4622. When low, it asserts mute on the outputs that are enabled in the audio flow.

RESET

Active-low reset signal. After $\overline{\text{RESET}}$ goes high, all the circuit blocks are powered down. The blocks can be individually powered up with software. When the part is powered up, it takes approximately 3072 internal clocks to initialize the internal circuitry. The internal system clock is equal to MCLKI until the PLL is powered and enabled, after which the internal system clock becomes $2560 \times f_s$ (122.88 MHz). Once the PLL is powered up and enabled after reset, it takes approximately 3 ms to lock. When the audio processor is enabled, it takes approximately 32,768 internal system clocks to initialize and load the default flow to the audio processor memory. The audio processor is not available during this time.

AUXIN1L, AUXIN2L, AUXIN1R, AND AUXIN2R

Analog inputs to the on-chip ADCs.

AUXOUT1L, AUXOUT2L, AUXOUT3L, AUXOUT4L, AUXOUT1R, AUXOUT2R, AUXOUT3R, AND AUXOUT4R

Auxiliary DAC analog outputs. These pins can be programmed to supply the outputs of the internal audio processing for line out or record use.

HPOUT1L, HPOUT2L, HPOUT1R, AND HPOUT2R

Analog outputs from the headphone amplifiers.

PLL_LF

PLL loop filter connection. A 100 nF capacitor and a 2 k Ω resistor in parallel with a 1 nF capacitor tied to AVDD are required for the PLL loop filter to operate correctly.

VREF

Voltage reference for DACs and ADCs. This pin is driven by an internal 1.5 V reference voltage.

FILTA AND FILTD

Decoupling nodes for the ADC and DAC. Decoupling capacitors should be connected between these nodes and AGND, typically 47 $\mu\text{F}/0.1 \mu\text{F}$ and 10 $\mu\text{F}/0.1 \mu\text{F}$, respectively.

PWM1A, PWM1B, PWM2A, PWM2B, PWM3A, PWM3B, PWM4A, AND PWM4B

Differential pulse-width modulation outputs are suitable for driving Class-D amplifiers.

PWM_READY

This pin is set high when PWM is enabled and stable.

AVDD

Analog power supply pins. These pins should be connected to 3.3 V. Each pin should be decoupled with 10 μF and 0.1 μF capacitors to AGND, as close to the pin as possible.

DVDD

Digital power supply. This pin is connected to a 1.8 V digital supply. Connecting 10 μF and 0.1 μF decoupling capacitors to DGND, as close to the pin as possible, is strongly recommended for optimal performance.

ODVDD

Digital interface power supply pin. This pin should be connected to a 3.3 V digital supply. The pin should be decoupled with 10 μF and 0.1 μF capacitors to DGND, as close to the pin as possible.

DGND

Digital ground.

AGND

Analog ground.

ODGND

Ground for the digital interface power supply.

SIF_REFP, SIF_REFCM, AND SIF_REFN

Decoupling nodes for the SIF block.

SIF_IN1 AND SIF_IN2

Analog inputs for the SIF block.

SIF_PGA_REF

PGA reference output. This pin should be decoupled to AGND with 10 μF and 0.1 μF capacitors.

ISET

ADC current setting resistor.

FUNCTIONAL DESCRIPTIONS

SIF PROCESSOR

Supported SIF Standards

The ADAV4622 supports all worldwide standards, as shown in Table 6.

Table 6. ADAV4622 Worldwide SIF Standards

System	Sound	SC1 (MHz)	SC2 (MHz)
M	BTSC	4.5	–
N	BTSC	4.5	–
M	EIAJ	4.5	–
M	A2	4.5	4.724
BG	A2	5.5	5.742
BG	NICAM	5.5	5.85
I	Mono	6.0	–
I	NICAM	6.0	6.552
DK1	A2	6.5	6.258
DK2	A2	6.5	6.742
DK3	A2	6.5	5.742
DK	NICAM	6.5	5.85
L	Mono	6.5	–
L	NICAM	6.5	5.85

SIF Demodulation

Figure 22 shows a block diagram of the SIF demodulation block. The selected SIF input signal is digitized by an ADC with a sample rate of 24.576 MHz. An AGC is included to ensure that for even low level signals, the full range of the ADC is used. The digitized input is passed to the SIF demodulator for demodulating. The outputs of the demodulator are then passed to the internal audio processor. Internally, the audio processor runs at a 48 kHz sampling frequency. When NICAM is selected, an internal SRC upsamples the 32 kHz NICAM signal to the audio processor rate of 48 kHz.

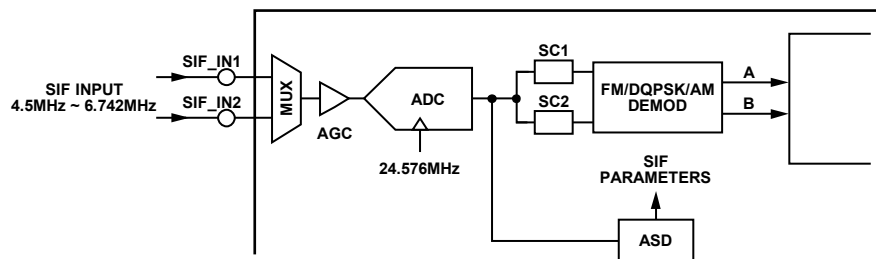

Figure 22. SIF Demodulation

SIF Processor Configuration

The ADAV4622 supports automatic standard detection, which is enabled by default. The ASD controller configures the SIF processor with the optimum register settings based on the detected standard. If the user prefers to operate in manual mode, or if the user prefers to use an external ASD loop, all of the ASD status registers are available.

MASTER CLOCK OSCILLATOR

Internally, the ADAV4622 operates synchronously to the master MCLKI input. All internal system clocks are generated from this single clock input using an internal PLL. This MCLKI input can also be generated by an external crystal oscillator connected to the MCLKI/XIN pin or by using a simple crystal resonator connected across MCLKI/XIN and XOUT. By default, the master clock frequency is 24.576 MHz; however, by using the internal dividers, an MCLKI of 12.288 MHz, 6.144 MHz, and 3.072 MHz are also supported.

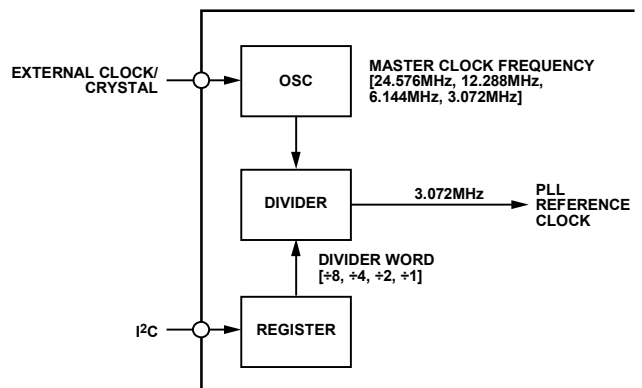

Figure 21. Master Clock

07068-018

07068-020

ADAV4622

I²C INTERFACE

The ADAV4622 supports a 2-wire serial (I²C compatible) microprocessor bus driving multiple peripherals. The ADAV4622 is controlled by an external I²C master device, such as a microcontroller. The ADAV4622 is in slave mode on the I²C bus, except during self-boot. While the ADAV4622 is self-booting, it becomes the master, and the EEPROM, which contains the ROMs to be booted, is the slave. When the self-boot process is complete, the ADAV4622 reverts to slave mode on the I²C bus. No other devices should access the I²C bus while the ADAV4622 is self-booting (refer to the Application Layer section and the Loading a Custom Audio Processing Flow section).

Initially, all devices on the I²C bus are in an idle state, wherein the devices monitor the SDA and SCL lines for a start condition and the proper address. The I²C master initiates a data transfer by establishing a start condition, defined by a high-to-low transition on SDA while SCL remains high. This indicates that an address/data stream follows. All devices on the bus respond to the start condition and read the next byte (7-bit address plus the R/W bit) MSB first. The device that recognizes the transmitted address responds by pulling the data line low during the ninth clock pulse. This ninth bit is known as an acknowledge bit. All other devices on the bus revert to an idle condition. The R/W bit determines the direction of the data. A Logic Level 0 on the LSB of the first byte means the master writes information to the peripheral. A Logic Level 1 on the LSB of the first byte means the master reads information from the peripheral. A data transfer takes place until a stop condition is encountered. A stop condition occurs when SDA transitions from low to high while SCL is held high.

The ADAV4622 determines its I²C device address by sampling the SDO0 pin after reset. Internally, the SDO0 pin is sampled by four MCLKI edges to determine the state of the pin (high or low). Because the pin has an internal pull-down resistor default, the address of the ADAV4622 is 0x34 (write) and 0x35 (read). An alternate address, 0x36 (write) and 0x37 (read), is available by tying the SDO0 pin to ODVDD via a 10 kΩ resistor. The I²C interface supports a clock frequency up to 400 kHz.

ADC INPUTS

The ADAV4622 has four ADC inputs. By default, these are configured as two stereo inputs; however, because the audio processor is programmable, these inputs can be reconfigured.

The ADC inputs are shown in Figure 23. The analog inputs are current inputs (100 μA rms FS) with a 1.5 V dc bias voltage. Any input voltage can be accommodated by choosing a suitable combination of input resistor (R_{IN}) and ISET resistor (R_{ISET}) using the formulas

$$R_{IN} = V_{FS\ rms} / 100\ \mu A$$

$$R_{ISET} = 2R_{IN} / V_{IN}$$

Resistor matching (typically 1%) between R_{IN} and R_{ISET} is important to ensure a full-scale signal on the ADC without clipping.

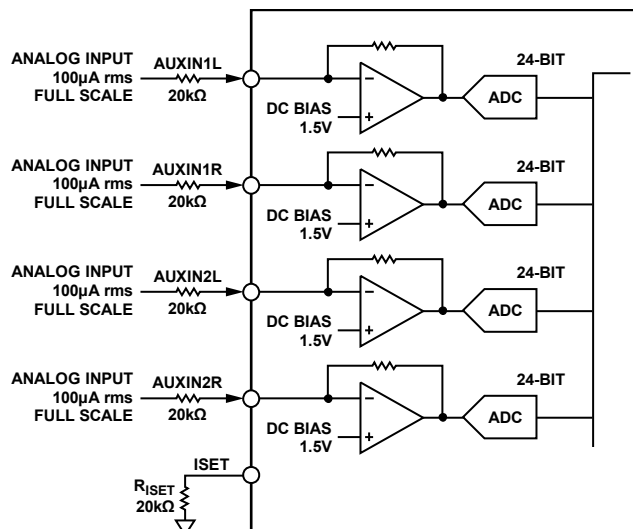

Figure 23. Analog Input Section

I²S DIGITAL AUDIO INPUTS

The ADAV4622 has four I²S digital audio inputs that are, by default, synchronous to the master clock. Also available are two SRCs capable of supporting any nonsynchronous input with a sample rate between 5 kHz and 50 kHz. Any of the serial digital inputs can be redirected through the SRC. Figure 24 shows a block diagram of the input serial port.

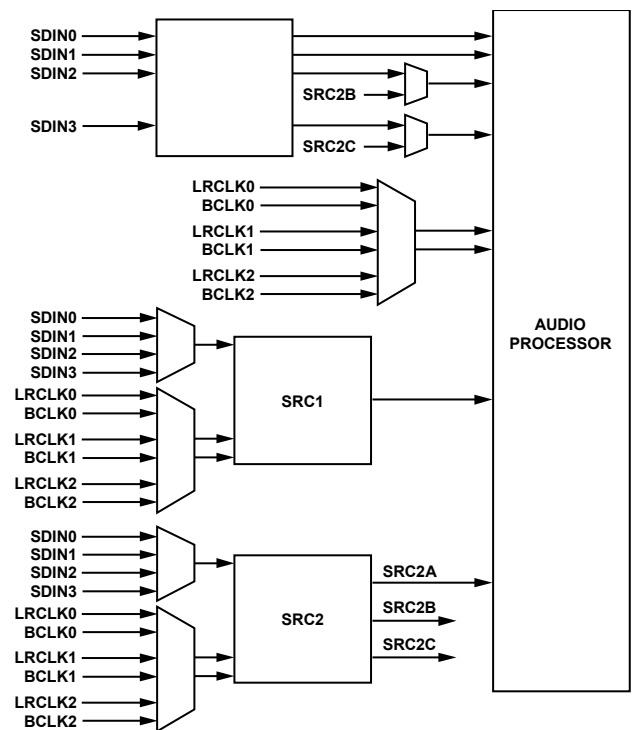

Figure 24. Digital Input Section

Synchronous Inputs and Outputs

The synchronous digital inputs and outputs can use any of the BCLK or LRCLK inputs as a clock and framing signal. By default, BCLK1 and LRCLK1 are the serial clocks used for the synchronous inputs. The synchronous port for the ADAV4622 is in slave mode by default, which means the user must supply the appropriate serial clocks, BCLK and LRCLK. The synchronous port can also be set to master mode, which means that the appropriate serial clocks, BCLK and LRCLK, can be generated internally from the MCLK; therefore, the user does not need to provide them. The serial data inputs are capable of accepting all the popular audio transmission standards (see the Serial Data Interface section for more details).

Asynchronous Inputs

The ADAV4622 has two SRCs, SRC1 and SRC2, that can be used for converting digital data, which is not synchronous to the master clock. Each SRC can accept input sample rates in the range of 5 kHz to 50 kHz. Data that has been converted by the SRC is inputted to the part and is then synchronous to the internal audio processor.

The SRC1 is a 2-channel (single-stereo) sample rate converter that is capable of using any of the three serial clocks available. The SRC1 can accept data from any of the serial data inputs (SDIN0, SDIN1, SDIN2, and SDIN3). Once selected as an input to the SRC, this SDIN line is assumed to contain asynchronous data and is then masked as an input to the audio processor to ensure that asynchronous data is not processed as synchronous data. By default, SRC1 uses the LRCLK0 and BCLK0 as the clock and framing signals.

The SRC2 is a 6-channel (3-stereo) sample rate converter that is capable of using any of the three serial clocks available. The SRC2 can accept data from any of the serial data inputs (SDIN0, SDIN1, SDIN2, and SDIN3). Once selected as an input to the SRC, this SDIN line is assumed to contain asynchronous data and is then masked internally as an input to the audio processor to ensure that asynchronous data is not processed as synchronous data. By default, SRC2 uses the LRCLK2 and BCLK2 as the clock and framing signals.

The first output (SRC2A) from SRC2 is always available to the audio processor. The other two outputs are muxed with two of the serial inputs before being available to the audio processor. SRC2B is muxed with SDIN2 and SRC2C is muxed with SDIN3. By default, these muxes are configured so that the synchronous inputs are available to the audio processor. The SRC2B and SRC2C channels can be made available to the audio processor simply by enabling them by register write.

When using the ADAV4622 in an asynchronous digital-in-to-digital-out configuration, the input digital data are input to the audio processor core from one of the SRCs, using the assigned BCLK/LRCLK as a framing signal. The digital output is synchronous to the BCLK/LRCLK, which is assigned to the

synchronous port; the default clocks in this case are BCLK1 and LRCLK1.

Serial Data Interface

LRCLK is the framing signal for the left- and right-channel inputs, with a frequency equal to the sampling frequency (f_s).

BCLK is the bit clock for the digital interface, with a frequency of $64 \times f_s$ (32 BCLK periods for each of the left and right channels).

The serial data interface supports all the popular audio interface standards, such as I²S, left-justified (LJ), and right-justified (RJ). The interface mode is software selectable, and its default is I²S. The data sample width is also software selectable from 16 bits, 20 bits, or 24 bits. The default is 24 bits.

I²S Mode

In I²S mode, the data are left-justified, MSB first, with the MSB placed in the second BCLK period following the transition of the LRCLK. A high-to-low transition of the LRCLK signifies the beginning of the left-channel data transfer, and a low-to-high transition on the LRCLK signifies the beginning of the right-channel data transfer (see Figure 26).

LJ Mode

In LJ mode, the data are left-justified, MSB first, with the MSB placed in the first BCLK period following the transition of the LRCLK. A high-to-low transition of the LRCLK signifies the beginning of the right-channel data transfer, and a low-to-high transition on the LRCLK signifies the beginning of the left-channel data transfer (see Figure 27).

RJ Mode

In RJ mode, the data are right-justified, LSB last, with the LSB placed in the last BCLK period preceding the transition of LRCLK. A high-to-low transition of the LRCLK signifies the beginning of the right-channel data transfer, and a low-to-high transition on the LRCLK signifies the beginning of the left-channel data transfer (see Figure 28).

DAC VOLTAGE OUTPUTS

The ADAV4622 has eight DAC outputs, configured as four stereo auxiliary DAC outputs. However, because the flow is customizable, this is programmable. The output level is 1 V rms full scale.

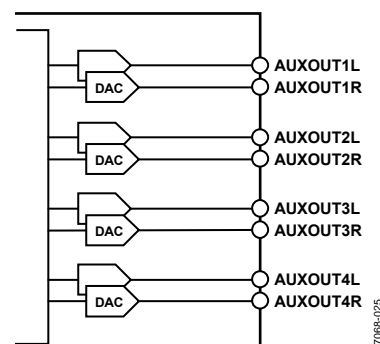

Figure 25. DAC Output Section

ADAV4622

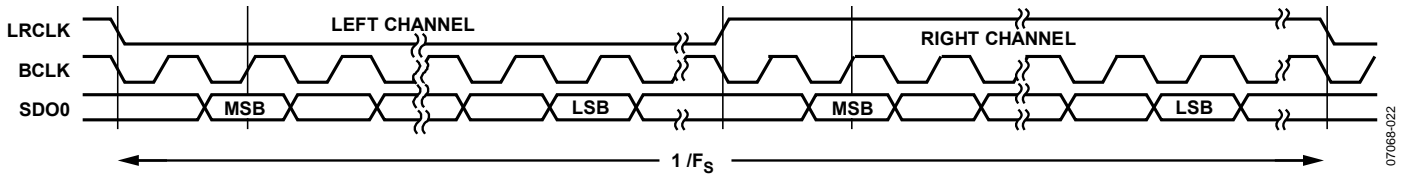

Figure 26. I²S Mode

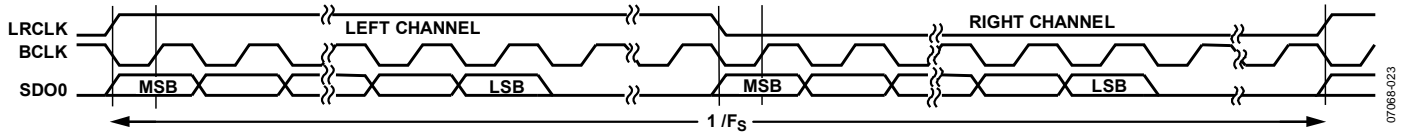

Figure 27. Left-Justified Mode

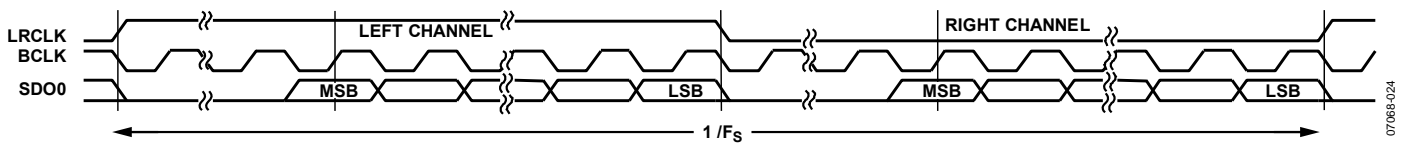

Figure 28. Right-Justified Mode

PWM OUTPUTS

In the ADAV4622, the main outputs are available as four PWM output channels, which are suitable for driving Class-D amplifiers. PWM_Ready is a status pin used to signify that the ADAV4622 PWM outputs are in a valid state. During PWM power-up and power-down, this pin remains low to signify that the outputs are not in a valid state. The output power stage should remain muted until this pin goes high. This functionality helps to eliminate pop/click and other unwanted noise on the outputs.

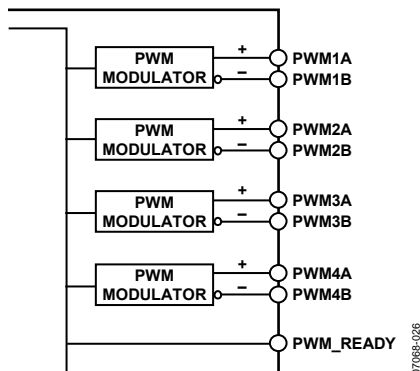

Figure 29. PWM Output Section

Each set of PWM outputs is a complementary output. The modulation frequency is 384 kHz, and the full-scale duty cycle has a ratio of 97:3.

Full details on the use of the PWM outputs are available upon request. Contact a local Analog Devices sales representative for more details.

HEADPHONE OUTPUTS

There are two stereo headphone amplifier outputs capable of driving 32 Ω loads at 1 V rms. HPOUT1 is shared with AUXOUT4, and HPOUT2 is shared with AUXOUT2, as shown in Figure 30.

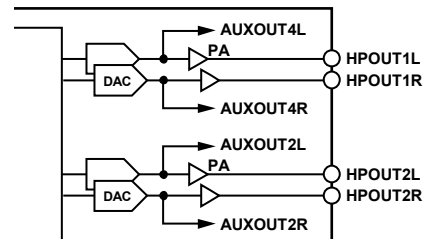

Figure 30. Headphone Outputs Section

I²S DIGITAL AUDIO OUTPUTS

One I²S output, SDO0, uses the same serial clocks as the serial inputs, which are BCLK1 and LRCLK1 by default. If an additional digital output is required, an additional pin can be reconfigured as a serial digital output, as shown in Figure 31.

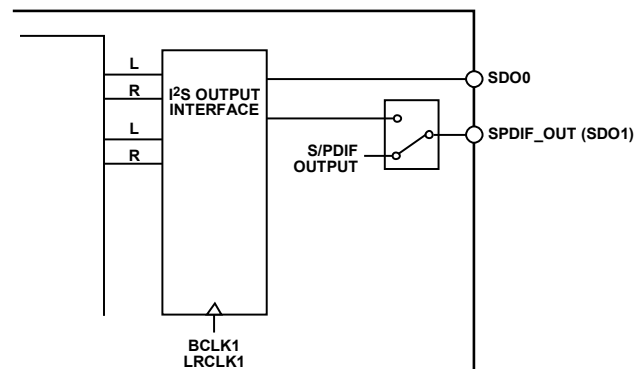

Figure 31. I²S Digital Outputs

S/PDIF INPUT/OUTPUT

The S/PDIF output (SPDIF_OUT/SDO1) uses a multiplexer to select an output from the audio processor or to pass through the unprocessed SPDIF_IN signals, as shown in Figure 32. On the ADAV4622, the S/PDIF inputs, SPDIF_IN0/SPDIF_IN1/SPDIF_IN2/SPDIF_IN3/SPDIF_IN4/SPDIF_IN5/SPDIF_IN6, are available on the SDIN3, LRCLK0, BCLK0, LRCLK1, BCLK1, LRCLK2, and BCLK2 pins, respectively. It is possible to have all seven S/PDIF inputs connected to different S/PDIF signals at one time. A consequence of this setup is that none of the LRCLKs and BCLKs are available for use with the digital inputs SDIN0, SDIN1, SDIN2, and SDIN3. If there is only one S/PDIF input in use, using the SDIN3 pin as the dedicated S/PDIF input is recommended; this enables BCLK0/LRCLK0, BCLK1/LRCLK1, and BCLK2/LRCLK2 to be used as the clock and framing signal for the synchronous and asynchronous port. If SDIN3 is used as an S/PDIF input, it should not be used internally as an input to the audio processor because it contains invalid data. Similarly, if BCLK or LRCLK are used as S/PDIF inputs, they can no longer be used as the clock and framing signals for SDIN0, SDIN1, SDIN2, and SDIN3. The S/PDIF encoder supports only consumer formats that conform to IEC-600958.

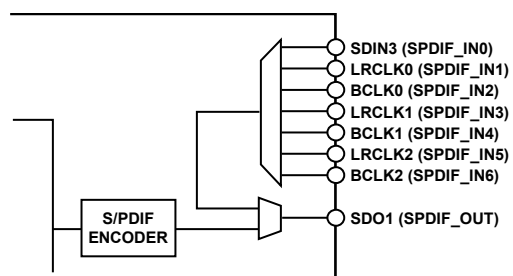

Figure 32. S/PDIF Output

HARDWARE MUTE CONTROL

The ADAV4622 mute input can be used to mute any of the analog or digital outputs. When the MUTE pin goes low, the selected outputs ramp to a muted condition. Unmuting is handled in one of two ways and depends on the register setting. By default, the MUTE pin going high causes the outputs to immediately ramp to an unmuted state. However, it is also possible to have the unmute operation controlled by a control register bit. In this scenario, even if the MUTE pin goes high, the device does not unmute until a bit in the control register is set. This can be used when the user wants to keep the outputs muted, even after the pin has gone high again, for example, in the case of a fault condition. This allows the system controller total control over the unmute operation.

Full details on register settings and operation of the mute function are available upon request. Contact a local Analog Devices sales representative for more details.

AUDIO PROCESSOR

The internal audio processor runs at $2560 \times f_s$; at 48 kHz, this is 122.88 MHz. Internally, the word size is 28 bits, which allows 24 dB of headroom for internal processing. Designed specifically with audio processing in mind, it can implement complex audio algorithms efficiently.

By default, the ADAV4622 loads a default audio flow, as shown in Figure 34. However, because the audio processor is fully programmable, a custom audio flow can be quickly developed and loaded to the audio processor.

The audio flow is contained in program RAM and parameter RAM. Program RAM contains the instructions to be processed by the audio processor, and parameter RAM contains the coefficients that control the flow, such as volume control, filter coefficients, and enable bits.

GRAPHICAL PROGRAMMING ENVIRONMENT

Custom flows for the ADAV4622 are created in a powerful drag-and-drop graphical programming application. No knowledge of assembly code is required to program the ADAV4622. Featuring a comprehensive library of audio processing blocks (such as filters, delays, dynamics processors, and third-party algorithms), it allows the quick and simple creation of custom flows. For debugging purposes, run-time control of the audio flow allows the user to fully configure and test the created flow.

Training materials and support are available upon request.

Contact a local Analog Devices sales representative for more details.

APPLICATION LAYER

Unique to this family is the embedded application layer, which allows the user to define a custom set of registers to control the audio flow, greatly simplifying the interface between the audio processor and the system controller.

Once a custom flow is created, a user-customized register map can be defined for controlling the flow. Each register is 16 bits, but controls can use only one bit or all 16 bits. Users have full control over which parameters they control and the degree of control they have over those parameters during run time. The combination of the graphical programming environment and the powerful application layer allows the user to quickly develop a custom audio flow and still maintain the usability of a simple register-based device.

Comprehensive documentation on developing a custom audio flow and the definition and creation of the custom application layer for the ADAV4622 is available upon request. Contact a local Analog Devices sales representative for more details.

ADAV4622

LOADING A CUSTOM AUDIO PROCESSING FLOW

The ADAV4622 can load a custom audio flow from an external I²C ROM. The boot process is initiated by a simple control register write. The EEPROM device address and the EEPROM start address for the audio flow ROMs can all be programmed.

For the duration of the boot sequence, the ADAV4622 becomes the master on the I²C bus. Transfer of the ROMs from the EEPROM to the ADAV4622 takes a maximum of 1.06 sec, assuming that the full audio processor memory is required, during which time no other devices should access the I²C bus. Once the transfer is complete, the ADAV4622 automatically reverts to slave mode, and the I²C bus master can resume sending commands.

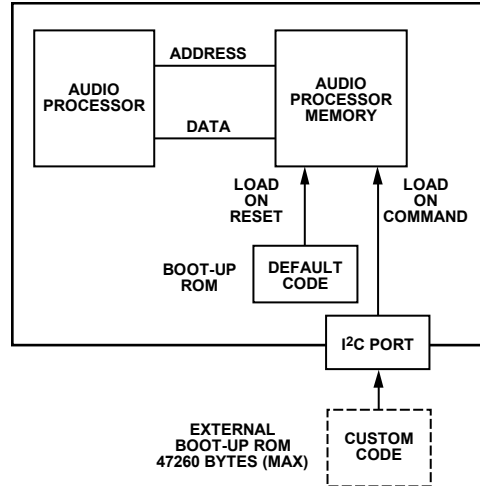

Figure 33. External EEPROM Booting

07058-030

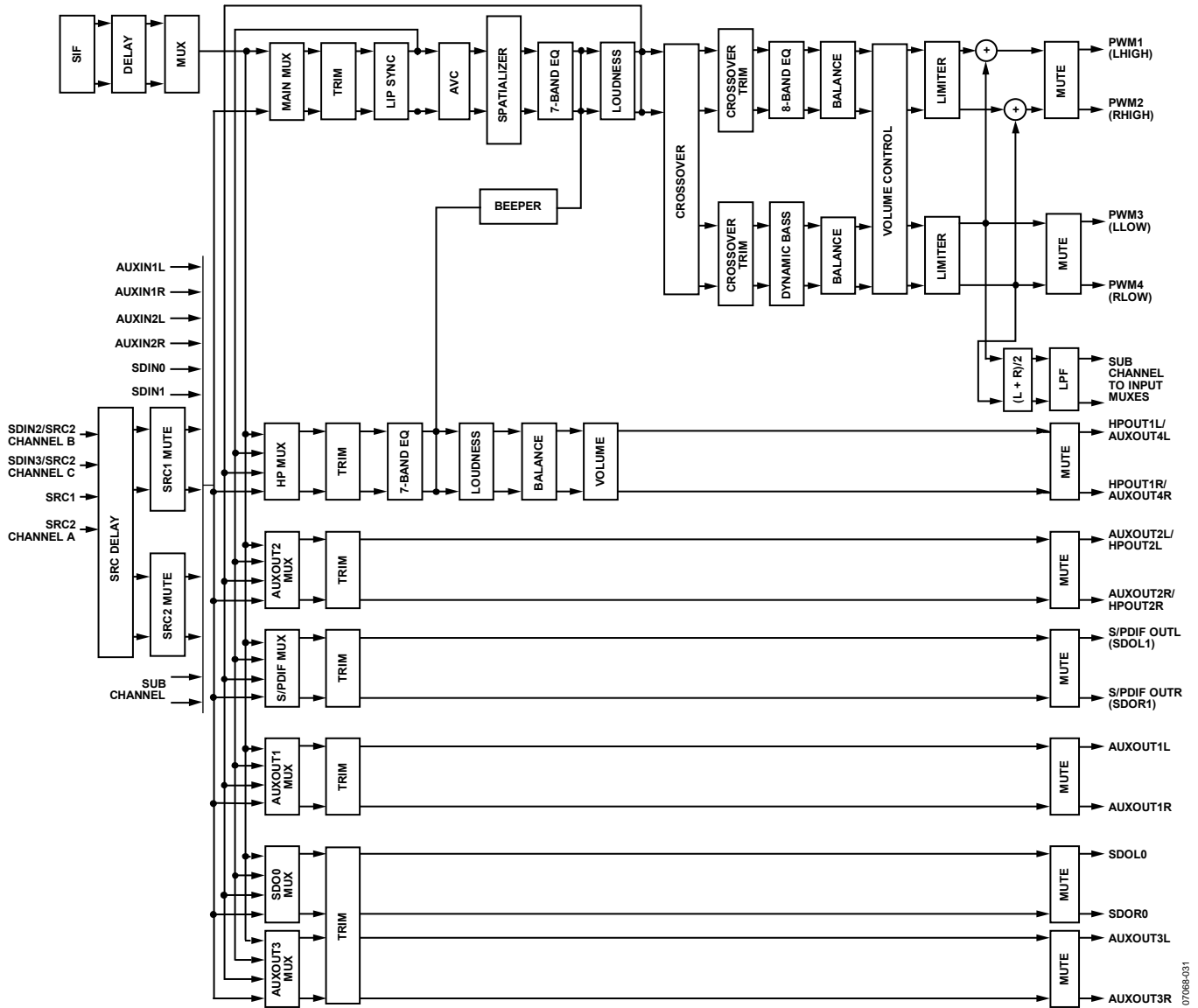
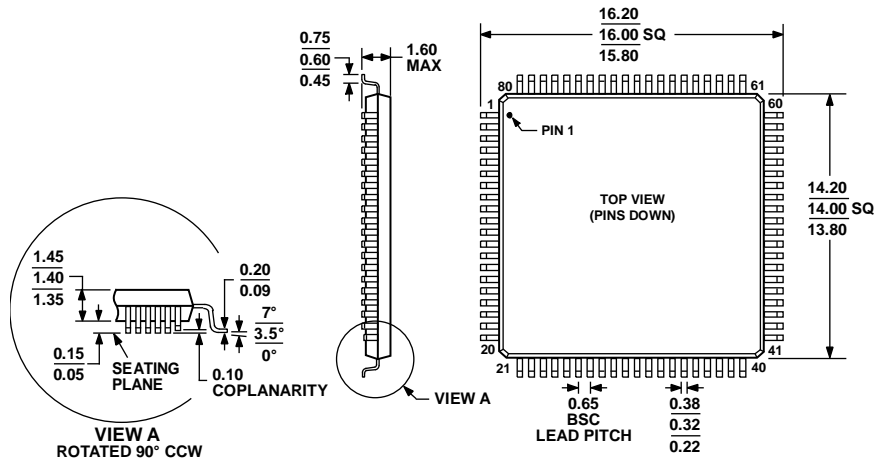

Figure 34. Default Audio Processing Flow

07068-031

OUTLINE DIMENSIONS



COMPLIANT TO JEDEC STANDARDS MS-026-BEC

Figure 35. 80-Lead Low Profile Quad Flat Package [LQFP] (ST-80-2)

Dimensions shown in millimeters

051706-A

ORDERING GUIDE

Model	Temperature Range	SIF Standard	Package Description	Package Option
ADAV4622BSTZ ¹	-40°C to +85°C	PAL/NTSC/SECAM	80-Lead Low Profile Quad Flat Package (LQFP)	ST-80-2
EVAL-ADAV4622EBZ ¹			Evaluation Board	

¹ Z = RoHS Compliant Part.

In addition, it is backward compatible with conventional SnPb soldering processes. This means the electroplated Sn coating can be soldered with Sn/Pb solder pastes at conventional reflow temperatures of 220°C to 235°C.

Purchase of licensed I²C components of Analog Devices or one of its sublicensed Associated Companies conveys a license for the purchaser under the Philips I²C Patent Rights to use these components in an I²C system, provided that the system conforms to the I²C Standard Specification as defined by Philips.

Looking for pricing, stock, or lifecycle information?

Click below to explore more details on WIN SOURCE:

- ⊖ [View EVAL-ADAV4622EBZ on WIN SOURCE](#)
- ⊖ [Analog Devices Inc. Information](#)

Optimize Your Supply Chain with WIN SOURCE Solutions

- ✓ Global Sourcing Solution
- ✓ Obsolete Management
- ✓ Cost Control Management
- ✓ Shortage Management
- ✓ Alternative Solution
- ✓ Excess Inventory Management