

## Features

- Minimal External Circuitry Requirements, no RF Components on the PC Board Except Matching to the Receiver Antenna
- High Sensitivity, Especially at Low Data Rates
- SSO20 and SO20 package
- Fully Integrated VCO
- Supply Voltage 4.5V to 5.5V, Operating Temperature Range  $-40^{\circ}\text{C}$  to  $+105^{\circ}\text{C}$
- Single-ended RF Input for Easy Adaptation to 1/4 Antenna or Printed Antenna on PCB
- Low-cost Solution Due to High Integration Level
- Various Types of Protocols Supported (i.e., PWM, Manchester and Bi-phase)
- Distinguishes the Signal Strength of Several Transmitters via RSSI (Received Signal Strength Indicator)
- ESD Protection According to MIL-STD. 883 (4KV HBM)
- High Image Frequency Suppression Due to 1 MHz IF in Conjunction with a SAW Front-end Filter, up to 40 dB is thereby Achievable with Newer SAWs
- Power Management (Polling) is Possible by Means of a Separate Pin via the Microcontroller
- Receiving Bandwidth BIF = 600 kHz



## UHF ASK Receiver

### ATA5744

## 1. Description

The ATA5744 is a PLL receiver device for the receiving range of  $f_0 = 300\text{ MHz}$  to  $450\text{ MHz}$ . It is developed for the demands of RF low-cost data communication systems with low data rates and fits for most types of modulation schemes including Manchester, Bi-phase and most PWM protocols. Its main applications are in the areas of telemetering, security technology and keyless-entry systems.

Figure 1-1. System Block Diagram

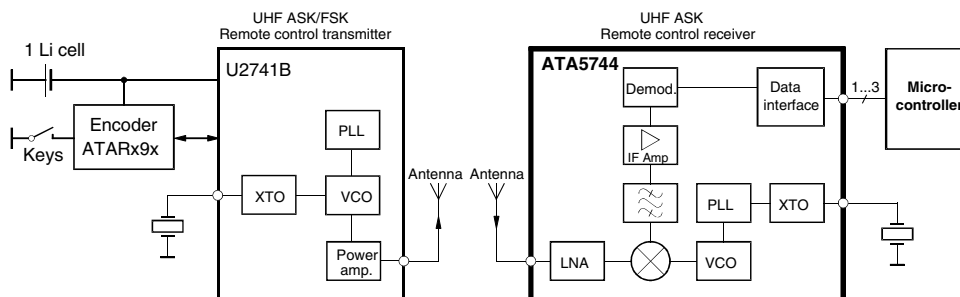

## 2. Pin Configuration

Figure 2-1. Pinning SO20 and SSO20

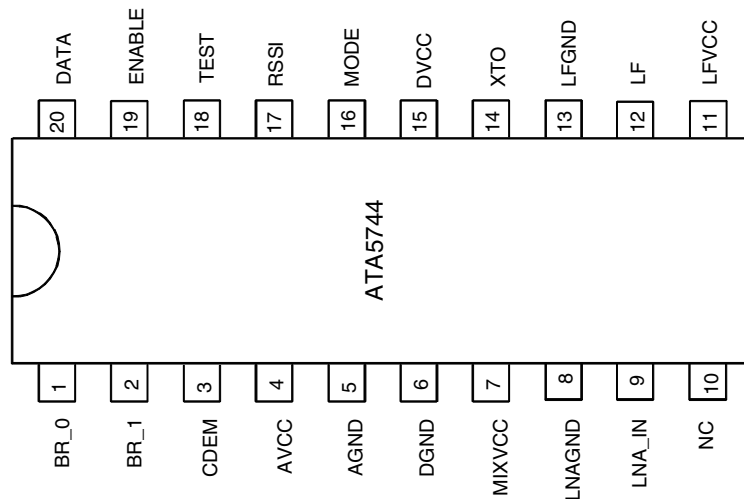
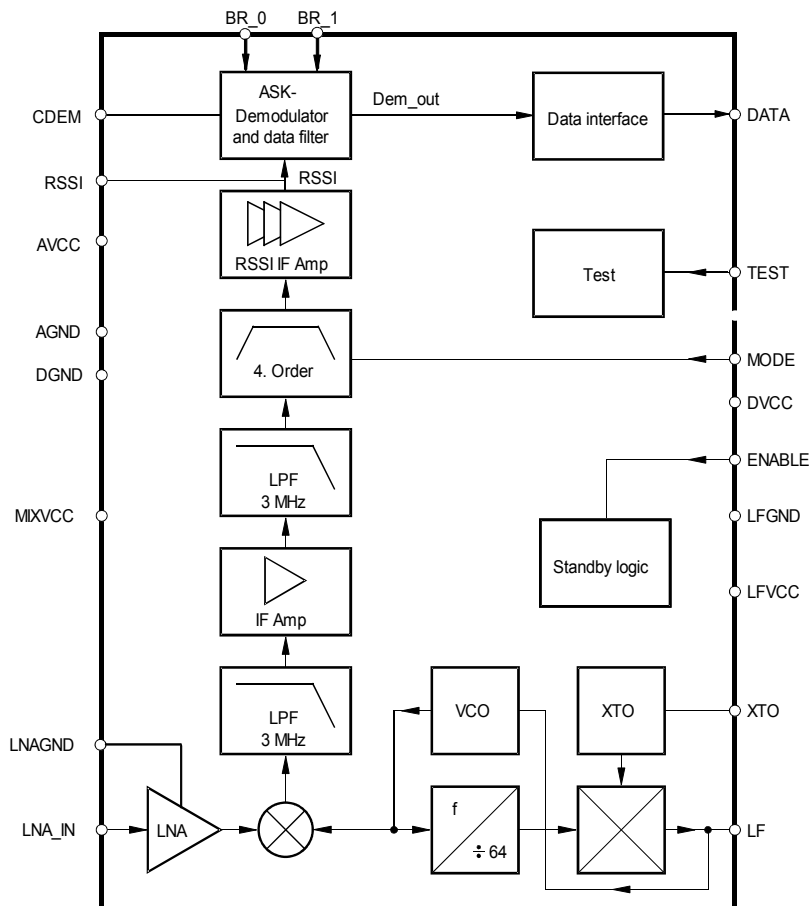

Table 2-1. Pin Description

Pin	Symbol	Function
1	BR_0	Baud rate select LSB
2	BR_1	Baud rate select MSB
3	CDEM	Lower cut-off frequency data filter
4	AVCC	Analog power supply
5	AGND	Analog ground
6	DGND	Digital ground
7	MIXVCC	Power supply mixer
8	LNAGND	High-frequency ground LNA and mixer
9	LNA_IN	RF input
10	NC	Not connected
11	LFVCC	Power supply VCO
12	LF	Loop filter
13	LFGND	Ground VCO
14	XTO	Crystal oscillator
15	DVCC	Digital power supply
16	MODE	Selecting 433.92 MHz /315 MHz Low: 315 MHz (USA) High: 433.92 MHz (Europe)
17	RSSI	Output of the RSSI amplifier
18	TEST	Test pin, during operation at GND
19	ENABLE	Selecting operation mode Low: sleep mode High: receiving mode
20	DATA	Data output

Figure 2-2. Block Diagram



### 3. RF Front End

The RF front end of the receiver is a heterodyne configuration that converts the input signal into a 1-MHz IF signal. According to Figure 2-2, the front end consists of an LNA (Low-Noise Amplifier), LO (Local Oscillator), a mixer and RF amplifier.

The LO generates the carrier frequency for the mixer via a PLL synthesizer. The XTO (crystal oscillator) generates the reference frequency  $f_{XTO}$ . The VCO (Voltage-Controlled Oscillator) generates the drive voltage frequency  $f_{LO}$  for the mixer.  $f_{LO}$  is dependent on the voltage at pin LF.  $f_{LO}$  is divided by factor 64. The divided frequency is compared to  $f_{XTO}$  by the phase frequency detector. The current output of the phase frequency detector is connected to a passive loop filter and thereby generates the control voltage VLF for the VCO. By means of that configuration, VLF is controlled in a way that  $f_{LO}/64$  is equal to  $f_{XTO}$ . If  $f_{LO}$  is determined,  $f_{XTO}$  can be calculated using the following formula:

$$f_{XTO} = f_{LO}/64$$

The XTO is a one-pin oscillator that operates at the series resonance of the quartz crystal. According to Figure 3-1, the crystal should be connected to GND via a capacitor CL. The value of that capacitor is recommended by the crystal supplier. The value of CL should be optimized for the individual board layout to achieve the exact value of  $f_{XTO}$  and hereby of  $f_{LO}$ . When designing the system in terms of receiving bandwidth, the accuracy of the crystal and the XTO must be considered.

**Figure 3-1.** PLL Peripherals

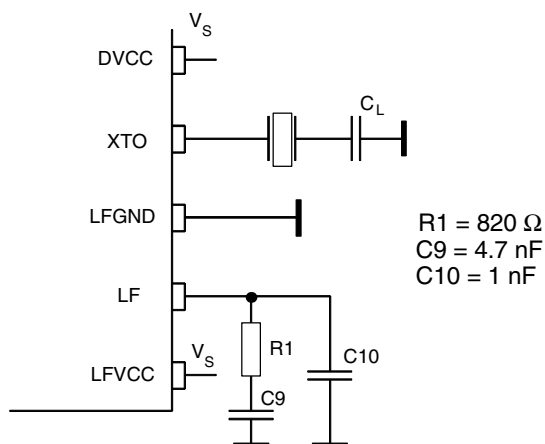

The passive loop filter connected to pin LF is designed for a loop bandwidth of  $B_{\text{Loop}} = 100 \text{ kHz}$ . This value for  $B_{\text{Loop}}$  exhibits the best possible noise performance of the LO. Figure 3-1 shows the appropriate loop filter components to achieve the desired loop bandwidth

$f_{\text{LO}}$  is determined by the RF input frequency  $f_{\text{RF}}$  and the IF frequency  $f_{\text{IF}}$  using the following formula:

$$f_{\text{LO}} = f_{\text{RF}} - f_{\text{IF}}$$

To determine  $f_{\text{LO}}$ , the construction of the IF filter must be considered at this point. The nominal IF frequency is  $f_{\text{IF}} = 1 \text{ MHz}$ . To achieve a good accuracy of the filter's corner frequencies, the filter is tuned by the crystal frequency  $f_{\text{XTO}}$ . This means that there is a fixed relation between  $f_{\text{IF}}$  and  $f_{\text{LO}}$  that depends on the logic level at pin mode. This is described by the following formulas:

$$\text{MODE} = 0 \text{ USA } f_{\text{IF}} = f_{\text{LO}}/314$$

$$\text{MODE} = 1 \text{ Europe } f_{\text{IF}} = f_{\text{LO}}/432.92$$

The relation is designed to achieve the nominal IF frequency of  $f_{\text{IF}} = 1 \text{ MHz}$  for most applications. For applications where  $f_{\text{RF}} = 315 \text{ MHz}$ , MODE must be set to '0'. In the case of  $f_{\text{RF}} = 433.92 \text{ MHz}$ , MODE must be set to '1'. For other RF frequencies,  $f_{\text{IF}}$  is not equal to 1 MHz.  $f_{\text{IF}}$  is then dependent on the logical level at pin MODE and on  $f_{\text{RF}}$ . Table 3-1 on page 5 summarizes the different conditions.

The RF input either from an antenna or from a generator must be transformed to the RF input pin LNA\_IN. The input impedance of that pin is provided in the electrical parameters. The parasitic board inductances and capacitances also influence the input matching. The RF receiver ATA5744 exhibits its highest sensitivity at the best signal-to-noise ratio in the LNA. Hence, noise matching is the best choice for designing the transformation network.

A good practice when designing the network, is to start with power matching. From that starting point, the values of the components can be varied to some extent to achieve the best sensitivity.

If a SAW is implemented into the input network a mirror frequency suppression of  $\Delta P_{\text{Ref}} = 40 \text{ dB}$  can be achieved. There are SAWs available that exhibit a notch at  $\Delta f = 2 \text{ MHz}$ . These SAWs work best for an intermediate frequency of  $\text{IF} = 1 \text{ MHz}$ . The selectivity of the receiver is also improved by using a SAW. In typical automotive applications, a SAW is used.

Figure 3-2 shows a typical input matching network for  $f_{RF} = 315$  MHz and  $f_{RF} = 433.92$  MHz using a SAW. Figure 3-3 on page 6 illustrates the input matching to 50Ω without a SAW. The input matching networks shown in Figure 3-3 on page 6 are the reference networks for the parameters given in the electrical characteristics.

**Table 3-1.** Calculation of LO and IF Frequency

Conditions	Local Oscillator Frequency	Intermediate Frequency
$f_{RF} = 315$ MHz, MODE = 0	$f_{LO} = 314$ MHz	$f_{IF} = 1$ MHz
$f_{RF} = 433.92$ MHz, MODE = 1	$f_{LO} = 432.92$ MHz	$f_{IF} = 1$ MHz
$300$ MHz < $f_{RF}$ < $365$ MHz, MODE = 0	$f_{LO} = \frac{f_{RF}}{1 + \frac{1}{314}}$	$f_{IF} = \frac{f_{LO}}{314}$
$365$ MHz < $f_{RF}$ < $450$ MHz, MODE = 1	$f_{LO} = \frac{f_{RF}}{1 + \frac{1}{432.92}}$	$f_{IF} = \frac{f_{LO}}{432.92}$

**Figure 3-2.** Input Matching Network with SAW Filter

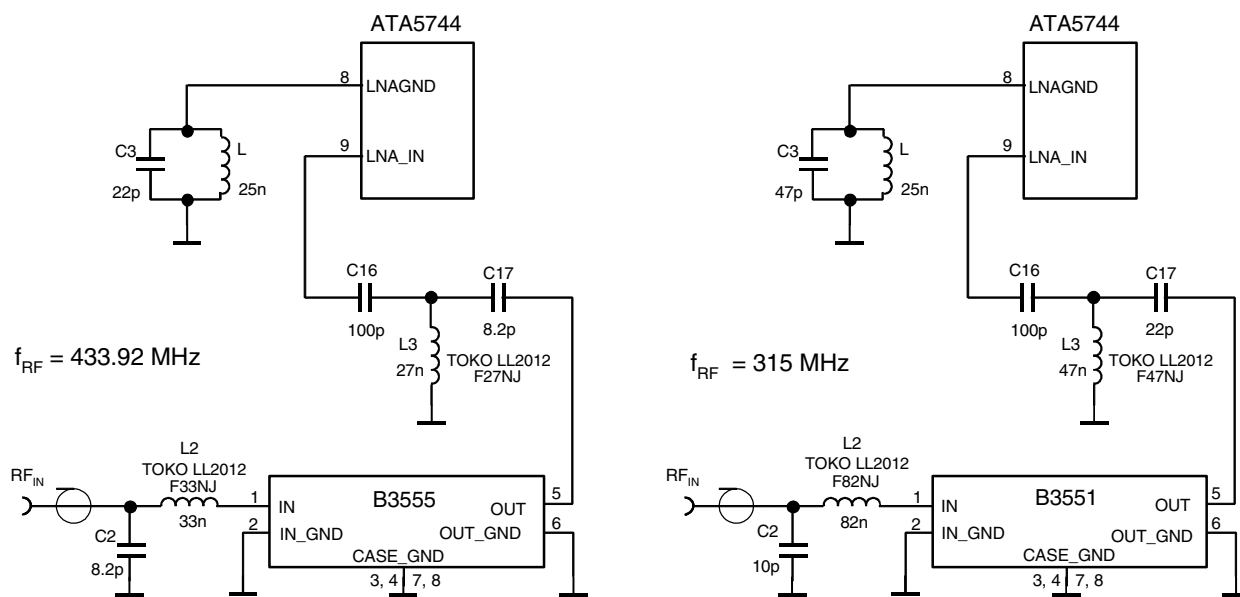

**Figure 3-3.** Input Matching Network without SAW Filter

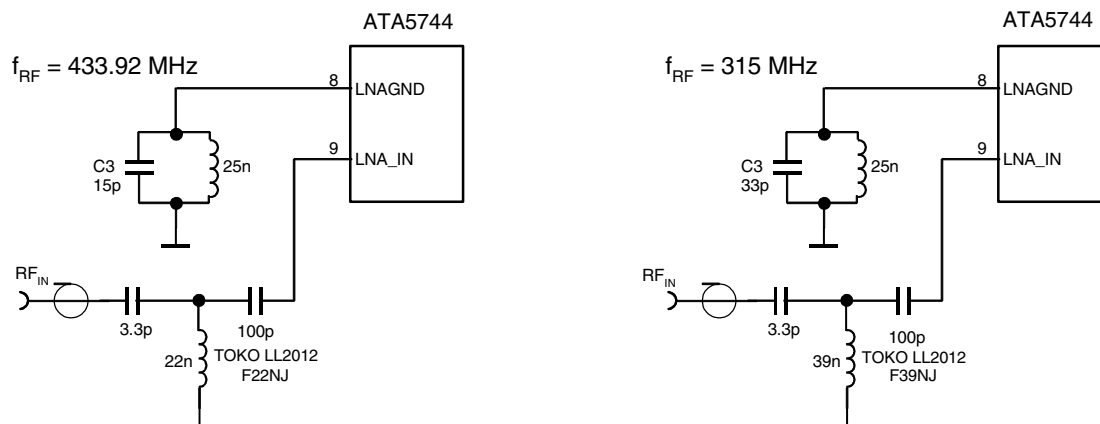

Please note that for all coupling conditions (see [Figure 3-2 on page 5](#) and [Figure 3-3](#)), the bond wire inductivity of the LNA ground is compensated. C3 forms a series resonance circuit together with the bond wire. L = 25 nH is a feed inductor to establish a DC path. Its value is not critical but must be large enough not to detune the series resonance circuit. For cost reduction, this inductor can be easily printed on the PCB. This configuration improves the sensitivity of the receiver by about 1 dB to 2 dB.

## 4. Analog Signal Processing

### 4.1 IF Amplifier

The signals coming from the RF front end are filtered by the fully integrated 4th-order IF filter. The IF center frequency is  $f_{IF} = 1$  MHz for applications where  $f_{RF} = 315$  MHz or  $f_{RF} = 433.92$  MHz is used. For other RF input frequencies, refer to [Table 3-1 on page 5](#) to determine the center frequency.

The receiver ATA5744 employs an IF bandwidth of  $B_{IF} = 600$  kHz and can be used together with the U2741B in ASK mode.

### 4.2 RSSI Amplifier

The subsequent RSSI amplifier enhances the output signal of the IF amplifier before it is fed into the demodulator. The dynamic range of this amplifier is  $DR_{RSSI} = 60$  dB. If the RSSI amplifier is operated within its linear range, the best S/N ratio is maintained. If the dynamic range is exceeded by the transmitter signal, the S/N ratio is defined by the ratio of the maximum RSSI output voltage and the RSSI output voltage due to a disturber. The dynamic range of the RSSI amplifier is exceeded if the RF input signal is about 60 dB higher compared to the RF input signal at full sensitivity.

### 4.3 Pin RSSI

The output voltage of the RSSI amplifier (VRSSI) is available at pin RSSI. Using the RSSI output signal, the signal strength of different transmitters can be distinguished. The usable input power range  $P_{Ref}$  is  $-100$  dBm to  $-55$  dBm.

Since different RF input networks may exhibit slightly different values for the LNA gain, the sensitivity values given in the electrical characteristics refer to a specific input matching. This matching is illustrated in Figure 3-3 and exhibits the best possible sensitivity.

**Figure 4-1.** RSSI Characteristics

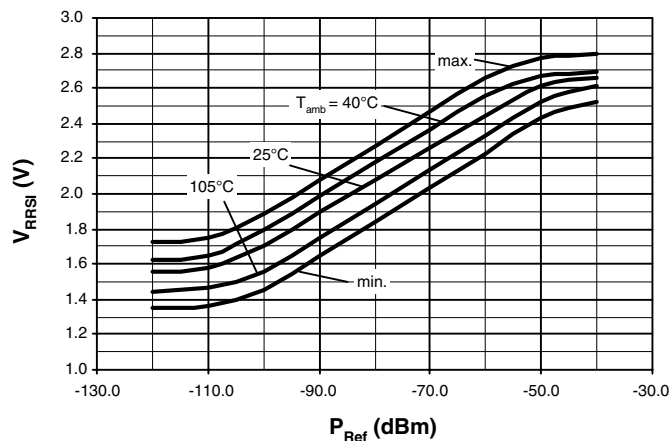

### 4.4 ASK Demodulator and Data Filter

The signal coming from the RSSI amplifier is converted into the raw data signal by the ASK demodulator.

An automatic threshold control circuit (ATC) is employed to set the detection reference voltage to a value where a good signal-to-noise ratio is achieved. This circuit also implies the effective suppression of any kind of inband noise signals or competing transmitters. If the S/N ratio exceeds 10 dB, the data signal can be detected properly.

The output signal of the demodulator is filtered by the data filter before it is fed into the digital signal processing circuit. The data filter improves the S/N ratio as its passband can be adopted to the characteristics of the data signal. The data filter consists of a 1st-order highpass and a 1st-order lowpass filter.

The highpass filter cut-off frequency is defined by an external capacitor connected to pin CDEM. The cut-off frequency of the highpass filter is defined by the following formula:

$$f_{cu\_DF} = \frac{1}{2 \times \pi \times R_1 \times CDEM}$$

Recommended values for CDEM are given in the electrical characteristics.

The cut-off frequency of the lowpass filter is defined by the selected baudrate range (BR\_Range). BR\_Range is defined by the pins BR\_0 and BR\_1. BR\_Range must be set in accordance to the used baudrate.

**Table 4-1.** Definition of BR\_Range by the Pins BR\_0 and BR\_1

BR_1	BR_0	BR_Range
0	0	0
0	1	1
1	0	2
1	1	2

Each BR\_Range is defined by a minimum and a maximum edge-to-edge time (tee\_sig). These limits are defined in the electrical characteristics. They should not be exceeded to maintain full sensitivity of the receiver.

## 4.5 Receiving Characteristics

The RF receiver ATA5744 can be operated with and without a SAW front-end filter. In a typical automotive application, a SAW filter is used to achieve better selectivity. The selectivity with and without a SAW front-end filter is illustrated in [Figure 4-1 on page 7](#). Note that the mirror frequency is reduced by 40 dB. The plots are printed relatively to the maximum sensitivity. If a SAW filter is used, an insertion loss of about 4 dB must be considered.

When designing the system in terms of receiving bandwidth, the LO deviation must be considered as it also determines the IF center frequency. The total LO deviation is calculated to be the sum of the deviation of the crystal and the XTO deviation of the ATA5744. Low-cost crystals are specified to be within  $\pm 100$  ppm. The XTO deviation of the ATA5744 is an additional deviation due to the XTO circuit. This deviation is specified to be  $\pm 30$  ppm. If a crystal of  $\pm 100$  ppm is used, the total deviation is  $\pm 130$  ppm in that case. Note that the receiving bandwidth and the IF-filter bandwidth are equivalent.

**Figure 4-2.** Receiving Frequency Response

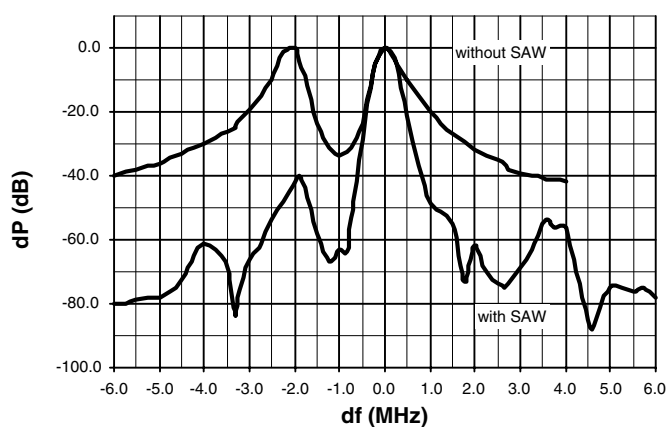

## 4.6 Basic Clock Cycle of the Digital Circuitry

The complete timing of the digital circuitry and the analog filtering is derived from one clock. According to Figure 4-3, this clock cycle  $T_{Clk}$  is derived from the crystal oscillator (XTO) in combination with a divider. The division factor is controlled by the logical state at pin MODE. According to chapter 'RF Front End', the frequency of the crystal oscillator ( $f_{XTO}$ ) is defined by the RF input signal ( $f_{RFIn}$ ) which also defines the operating frequency of the local oscillator ( $f_{LO}$ ).

**Figure 4-3.** Generation of the Basic Clock Cycle

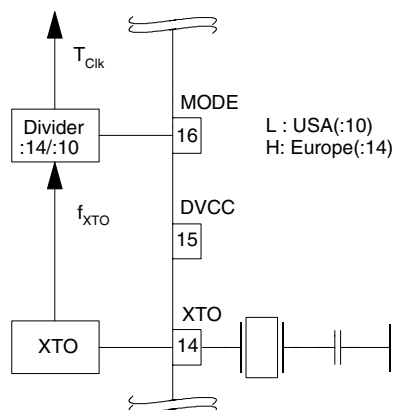

Pin MODE can now be set in accordance with the desired clock cycle  $T_{Clk}$ .  $T_{Clk}$  controls the following application-relevant parameters:

Timing of the analog and digital signal processing

IF filter center frequency ( $f_{IF0}$ )

Most applications are dominated by two transmission frequencies:  $f_{Send} = 315$  MHz is mainly used in USA,  $f_{Send} = 433.92$  MHz in Europe. In order to ease the usage of all  $T_{Clk}$ -dependent parameters, the electrical characteristics display three conditions for each parameter.

- Application USA  
( $f_{XTO} = 4.90625$  MHz, MODE = L,  $T_{Clk} = 2.0383$   $\mu$ s)
- Application Europe  
( $f_{XTO} = 6.76438$  MHz, MODE = H,  $T_{Clk} = 2.0697$   $\mu$ s)
- Other applications  
( $T_{Clk}$  is dependent on  $f_{XTO}$  and on the logical state of pin MODE. The electrical characteristic is given as a function of  $T_{Clk}$ ).

The clock cycle of some function blocks depends on the selected baud rate range (BR\_Range) which is defined by the pins BR\_0 and BR\_1. This clock cycle  $T_{XClk}$  is defined by the following formulas for further reference:

BR_Range = BR_Range0:	$T_{XClk} = 8 \times T_{Clk}$
BR_Range1:	$T_{XClk} = 4 \times T_{Clk}$
BR_Range2:	$T_{XClk} = 2 \times T_{Clk}$
BR_Range3:	$T_{XClk} = 1 \times T_{Clk}$

## 5. Pin ENABLE

Via the pin ENABLE the operating mode of the receiver can be selected (see [Figure 5-1](#) and [Figure 5-2](#)).

If the pin ENABLE is held to Low, the receiver remains in sleep mode. All circuits for signal processing are disabled and only the XTO is running in that case. The current consumption is  $I_S = I_{Soff}$  in that case. During the sleep mode the receiver is not sensitive to a transmitter signal.

To activate the receiver, the pin ENABLE must be held to High. During the start-up period,  $T_{Startup}$ , all signal processing circuits are enabled and settled. The duration of the start-up period depends on the selected baud-rate range (BR\_Range).

After the start-up period, all circuits are in a stable condition and the receiver is in the receiving mode.

In receiving mode, the internal data signal (Dem\_out) is switched to pin DATA. To avoid incorrect timing at the begin of the data stream, the begin is synchronized to a falling edge of the incoming data signal. The receiver stays in the receiving mode until it is switched back to sleep mode via pin ENABLE.

During start-up and receiving mode, the current consumption is  $I_S = I_{Son}$ .

**Figure 5-1.** Enable Timing (1)

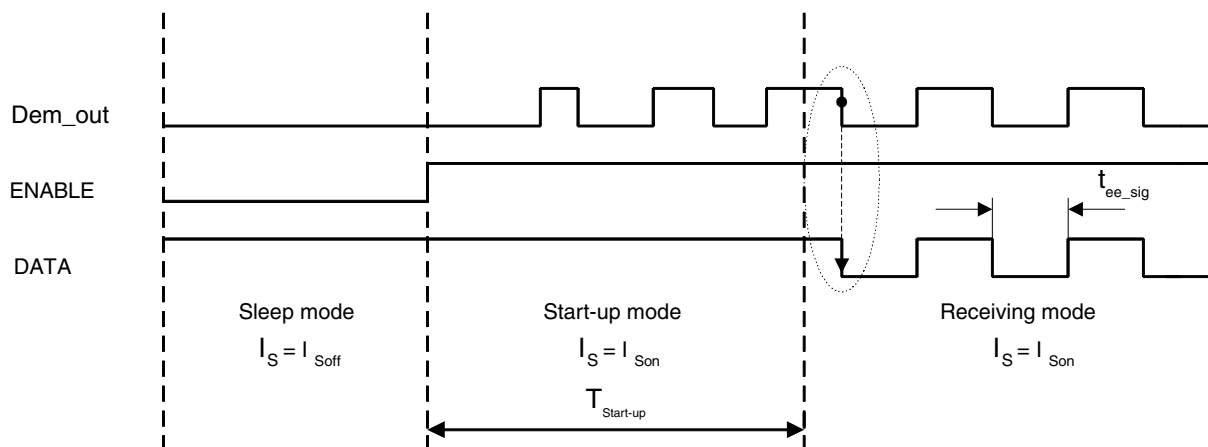

**Figure 5-2.** Enable Timing (2)

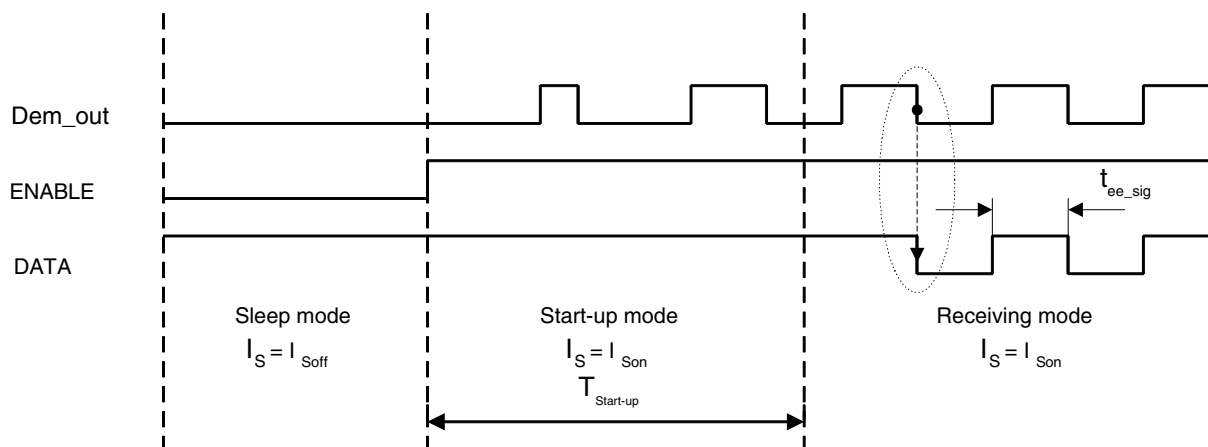

## 6. Digital Signal Processing

The data from the ASK demodulator (Dem\_out) is digitally processed in different ways and as a result converted into the output signal DATA. This processing depends on the selected baudrate range (BR\_Range). [Figure 6-1 on page 11](#) illustrates how Dem\_out is synchronized by the extended basic clock cycle  $T_{XClk}$ . Data can change its state only after  $T_{XClk}$  has elapsed. The edge-to-edge time period  $t_{ee\_sig}$  of the DATA signal as a result is always an integral multiple of  $T_{XClk}$ .

The minimum time period between two edges of the data signal is limited to  $t_{ee\_sig} \geq T_{DATA\_min}$ . This implies an efficient suppression of spikes at the DATA output. At the same time it limits the maximum frequency of edges at DATA. This eases the interrupt handling of a connected microcontroller.

**Figure 6-1.** Synchronization of the Demodulator Output

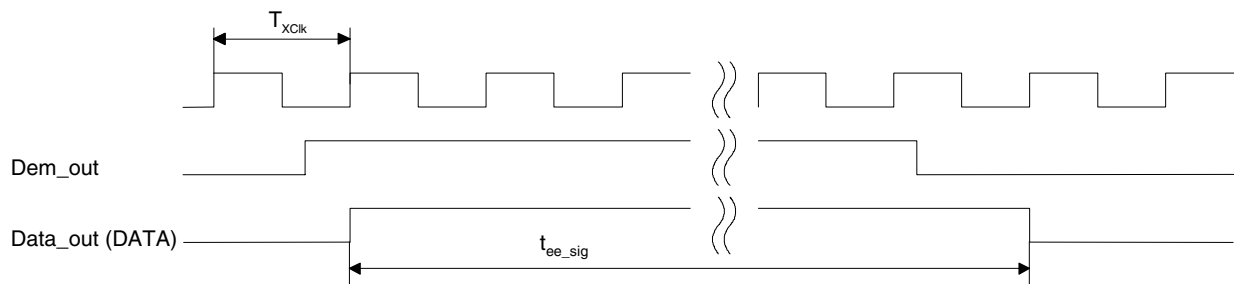

**Figure 6-2.** Debouncing of the Demodulator Output

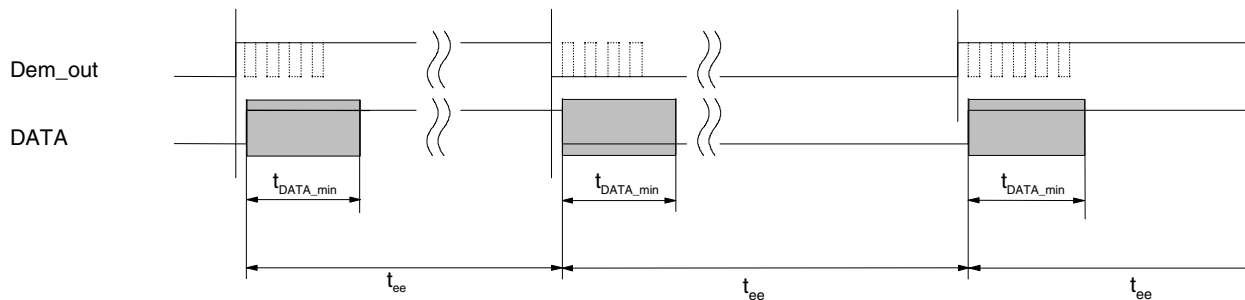

## 7. Absolute Maximum Ratings

Stresses beyond those listed under “Absolute Maximum Ratings” may cause permanent damage to the device. This is a stress rating only and functional operation of the device at these or any other conditions beyond those indicated in the operational sections of this specification is not implied. Exposure to absolute maximum rating conditions for extended periods may affect device reliability.

Parameters	Symbol	Min.	Max.	Unit
Supply voltage	$V_S$		6	V
Power dissipation	$P_{tot}$		450	mW
Junction temperature	$T_j$		150	°C
Storage temperature	$T_{stg}$	-55	+125	°C
Ambient temperature	$T_{amb}$	-40	+105	°C
Maximum input level, input matched to 50Ω	$P_{in\_max}$		10	dBm

## 8. Thermal Resistance

Parameters	Symbol	Value	Unit
Junction ambient SO20 package	$R_{thJA}$	100	K/W
Junction ambient SSO20 package	$R_{thJA}$	100	K/W

## 9. Electrical Characteristics

All parameters refer to GND,  $T_{amb} = -40^{\circ}\text{C}$  to  $+105^{\circ}\text{C}$ ,  $V_S = 4.5\text{V}$  to  $5.5\text{V}$ ,  $f_0 = 433.92\text{ MHz}$  and  $f_0 = 315\text{ MHz}$ , unless otherwise specified. ( $V_S = 5\text{V}$ ,  $T_{amb} = 25^{\circ}\text{C}$ )

Parameters	Test Conditions	Symbol	6.76438 MHz Osc. (MODE:1)			4.90625 MHz Osc. (MODE:0)			Variable Oscillator			Unit
			Min.	Typ.	Max.	Min.	Typ.	Max.	Min.	Typ.	Max.	
<b>Basic Clock Cycle of the Digital Circuitry</b>												
Basic clock cycle	MODE = 0 (USA) MODE = 1 (Europe)	$T_{Clk}$	2.0697		2.0697	2.0383		2.0383	$1/(f_{xto}/10)$ $1/(f_{xto}/14)$		$1/(f_{xto}/10)$ $1/(f_{xto}/14)$	$\mu\text{s}$ $\mu\text{s}$
Extended basic clock cycle	BR_Range0	$T_{XClk}$	16.6		16.6	16.3		16.3	$8 \times T_{Clk}$		$8 \times T_{Clk}$	$\mu\text{s}$
	BR_Range1		8.3		8.3	8.2		8.2	$4 \times T_{Clk}$		$4 \times T_{Clk}$	$\mu\text{s}$
	BR_Range2		4.1		4.1	4.1		4.1	$2 \times T_{Clk}$		$2 \times T_{Clk}$	$\mu\text{s}$
	BR_Range3		2.1		2.1	2.0		2.0	$1 \times T_{Clk}$		$1 \times T_{Clk}$	$\mu\text{s}$
Start-up time (see <a href="#">Figure 5-1</a> and <a href="#">Figure 5-2</a> on page 10)	BR_Range0	$T_{Startup}$	1855		1855	1827		1827	896.5		896.5	$\mu\text{s}$
	BR_Range1		1061		1061	1045		1045	512.5		512.5	$\mu\text{s}$
	BR_Range2		1061		1061	1045		1045	512.5		512.5	$\mu\text{s}$
	BR_Range3		663		663	653		653	$320.5 \times T_{Clk}$		$320.5 \times T_{Clk}$	$\mu\text{s}$
<b>Receiving Mode</b>												
Intermediate frequency	MODE=0 (USA) MODE=1 (Europe)	$f_{IF}$		1.0		1.0			$f_{XTO} \times 64/314$ $f_{XTO} \times 64/432.92$			MHz MHz
Minimum time period between edges at pin DATA ( <a href="#">Figure 6-2</a> on page 11)	BR_Range0	$T_{DATA\_min}$	165		165	163		163	$10 \times T_{XClk}$		$10 \times T_{XClk}$	$\mu\text{s}$
	BR_Range1		83		83	81		81	$10 \times T_{XCl}$		$10 \times T_{XCl}$	$\mu\text{s}$
	BR_Range2		41.4		41.4	40.7		40.7	$10 \times T_{XClk}$		$10 \times T_{XClk}$	$\mu\text{s}$
	BR_Range3		20.7		20.7	20.4		20.4	$10 \times T_{XClk}$		$10 \times T_{XClk}$	$\mu\text{s}$
Edge to edge time period of the data signal for full sensitivity ( <a href="#">Figure 5-1</a> on page 10)	BR_Range0 BR_Range1 BR_Range2 BR_Range3	$t_{ee\_sig}$	400 200 100 50		8479 8479 8479 8479	400 200 100 50		8350 8350 8350 8350	BR_Range $\times$ $2 \mu\text{s}/T_{CLK}$		$4097 \times T_{CLK}$	$\mu\text{s}$ $\mu\text{s}$ $\mu\text{s}$ $\mu\text{s}$

## 10. Electrical Characteristics (continued)

Parameters	Test Conditions	Symbol	Min.	Typ.	Max.	Unit
Current consumption	Sleep mode (XTO active)	$I_{Soff}$		190	276	$\mu\text{A}$
	IC active (startup-, receiving mode) pin DATA = H	$I_{Son}$		7.1	8.7	mA
<b>LNA Mixer</b>						
Third-order intercept point	LNA/ mixer/ IF amplifier input matched according to <a href="#">Figure 3-3</a> on page 6	IIP3		-28		dBm
LO spurious emission at $RF_{In}$	Input matched according to <a href="#">Figure 3-3</a> on page 6, required according to I-ETS 300220	$I_{S_{LORF}}$		-73	-57	dBm
Noise figure LNA and mixer (DSB)	Input matching according to <a href="#">Figure 3-3</a> on page 6	NF		7		dB
LNA_IN input impedance	At 433.92 MHz At 315 MHz	$Z_{i_{LNA\_IN}}$		1.0    1.56 1.3    1.0		k $\Omega$    pF k $\Omega$    pF

## 10. Electrical Characteristics (continued)

Parameters	Test Conditions	Symbol	Min.	Typ.	Max.	Unit
1 dB compression point (LNA, mixer, IF amplifier)	Input matched according to <a href="#">Figure 3-3 on page 6</a> , referred to $RF_{in}$	$IP_{1db}$		-40		dBm
Maximum input level	Input matched according to <a href="#">Figure 3-3 on page 6</a> , $BER \leq 10^{-3}$	$P_{in\_max}$			-20	dBm
<b>Local Oscillator</b>						
Operating frequency range VCO		$f_{VCO}$	299		449	MHz
Phase noise VCO/LO	$f_{osc} = 432.92$ MHz at 1 MHz at 10 MHz	L (fm)		-93 -113	-90 -110	dBc/Hz dBc/Hz
Spurious of the VCO	at $\pm f_{XTO}$			-55	-47	dBc
VCO gain		$K_{VCO}$		190		MHz/V
Loop bandwidth of the PLL	For best LO noise (design parameter) $R1 = 820\Omega$ $C9 = 4.7$ nF $C10 = 1$ nF	$B_{Loop}$		100		kHz
Capacitive load at pin LF		$C_{LF\_tot}$			10	nF
XTO operating frequency	XTO crystal frequency, appropriate load capacitance must be connected to XTAL $f_{XTAL} = 6.764375$ MHz (EU) $f_{XTAL} = 4.90625$ MHz (US)	$f_{XTO}$	6.764375 -30 ppm 4.90625 -30 ppm	6.764375 4.90625	6.764375 +30 ppm 4.90625 +30 ppm	MHz MHz
Series resonance resistor of the crystal	$f_{XTO} = 6.764$ MHz 4.906 MHz	$R_S$			150 220	$\Omega$ $\Omega$
Static capacitance of the crystal		$C_o$			6.5	pF
<b>Analog Signal Processing</b>						
Input sensitivity	Input matched according to <a href="#">Figure 3-3</a> ASK (level of carrier) $BER \leq 10^{-3}$ (Manchester), $f_{in} = 433.92$ MHz/ 315 MHz $T = 25^\circ C$ , $V_S = 5V$ , $f_{IF} = 1$ MHz	$P_{Ref\_ASK}$				
	BR_Range0 (1 kBd)		-107	-110	-112	dBm
	BR_Range1 (2 kBd)		-105	-108	-110	dBm
	BR_Range2 (4 kBd)		-103	-106	-108	dBm
	BR_Range3 (8 kBd)		-101	-104	-106	dBm
Sensitivity variation for the full operating range compared to $T_{amb} = 25^\circ C$ , $V_S = 5V$	$f_{in} = 433.92$ MHz/315 MHz $f_{IF} = 1$ MHz $P_{ASK} = P_{Ref\_ASK} + \Delta P_{Ref}$	$\Delta P_{Ref}$	+2.5		-1.5	dB

## 10. Electrical Characteristics (continued)

Parameters	Test Conditions	Symbol	Min.	Typ.	Max.	Unit
Sensitivity variation for full operating range including IF filter compared to $T_{amb} = 25^{\circ}\text{C}$ , $V_S = 5\text{V}$	$f_{in} = 433.92\text{ MHz} / 315\text{ MHz}$ $f_{IF} = 0.79\text{ MHz to } 1.21\text{ MHz}$ $f_{IF} = 0.73\text{ MHz to } 1.27\text{ MHz}$ $P_{ASK} = P_{Ref\_ASK} + \Delta P_{Ref}$	$\Delta P_{Ref}$	+5.5 +7.5		-1.5 -1.5	dB dB
S/N ratio to suppress inband noise signals		SNR		10	12	dB
Dynamic range RSSI amplifier		$\Delta R_{RSSI}$		60		dB
RSSI output voltage range		$V_{RSSI}$	1.0		3.0	V
RSSI gain		$G_{RSSI}$		20		mV/dB
RI of pin CDEM for cut-off frequency calculation	$f_{cu\_DF} = \frac{1}{2 \times \pi \times R_1 \times CDEM}$	$R_1$	28	40	55	k $\Omega$
Recommended CDEM for best performance	BR_Range0 BR_Range1 BR_Range2 BR_Range3	CDEM		33 18 10 6.8		nF nF nF nF
Upper cut-off frequency data filter	Upper cut-off frequency BR_Range0 BR_Range1 BR_Range2 BR_Range3	$f_u$	1.75 3.5 7.0 14.0	2.2 4.4 8.8 17.6	2.65 5.3 10.6 21.2	kHz kHz kHz kHz
<b>Digital Ports</b>						
Data output - Saturation voltage LOW - Internal pull-up resistor	$I_{ol} = 1\text{ mA}$	$V_{OI}$ $R_{Pup}$	39	0.08 50	0.3 65	V k $\Omega$
ENABLE input - Low-level input voltage - High-level input voltage	Sleep mode Receiving mode	$V_{ll}$ $V_{lh}$	$0.8 \times V_S$		$0.2 \times V_S$	V V
MODE input - Low-level input voltage - High-level input voltage	Division factor = 10 Division factor = 14	$V_{ll}$ $V_{lh}$	$0.8 \times V_S$		$0.2 \times V_S$	V V
BR_0 input - Low-level input voltage - High-level input voltage		$V_{ll}$ $V_{lh}$	$0.8 \times V_S$		$0.2 \times V_S$	V V
BR_1 input - Low-level input voltage - High-level input voltage		$V_{ll}$ $V_{lh}$	$0.8 \times V_S$		$0.2 \times V_S$	V V
TEST input - Low-level input voltage	Test input must always be set to LOW	$V_{ll}$			$0.2 \times V_S$	V

Figure 10-1. Application Circuit:  $f_{RF} = 433.92$  MHz, without SAW Filter

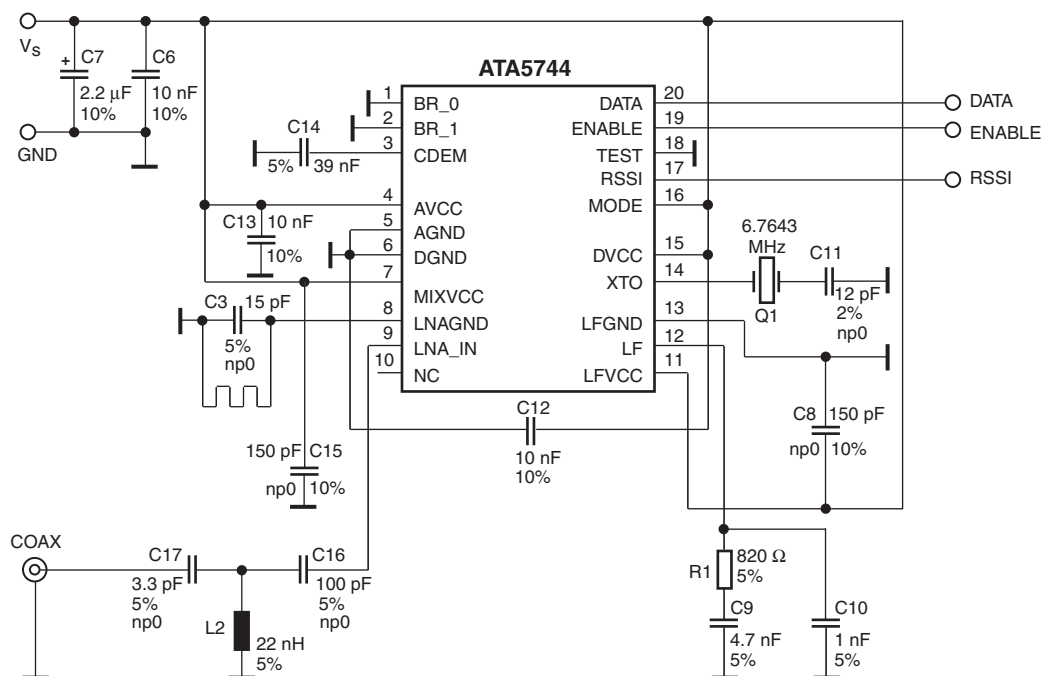

Figure 10-2. Application Circuit:  $f_{RF} = 315$  MHz, without SAW Filter

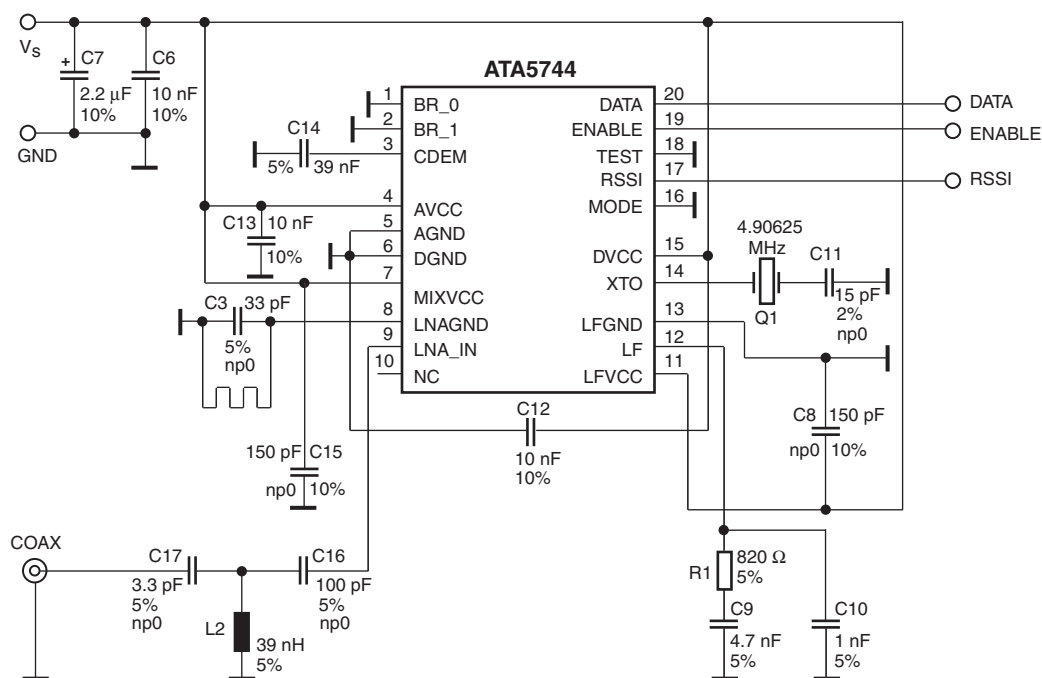

Figure 10-3. Application Circuit:  $f_{RF} = 433.92$  MHz, with SAW Filter

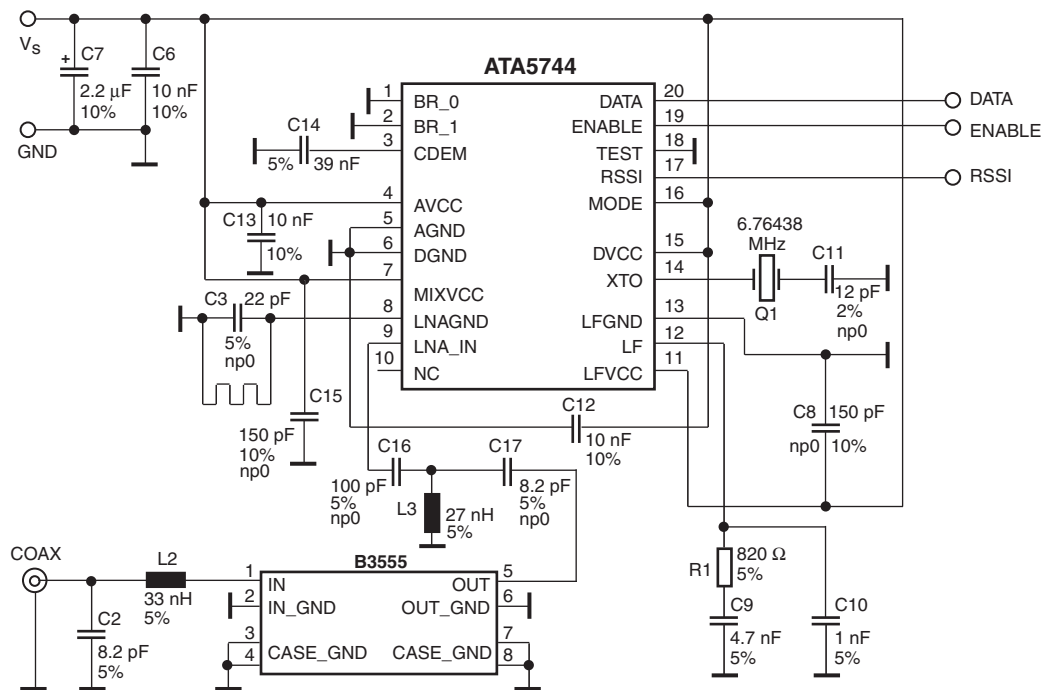
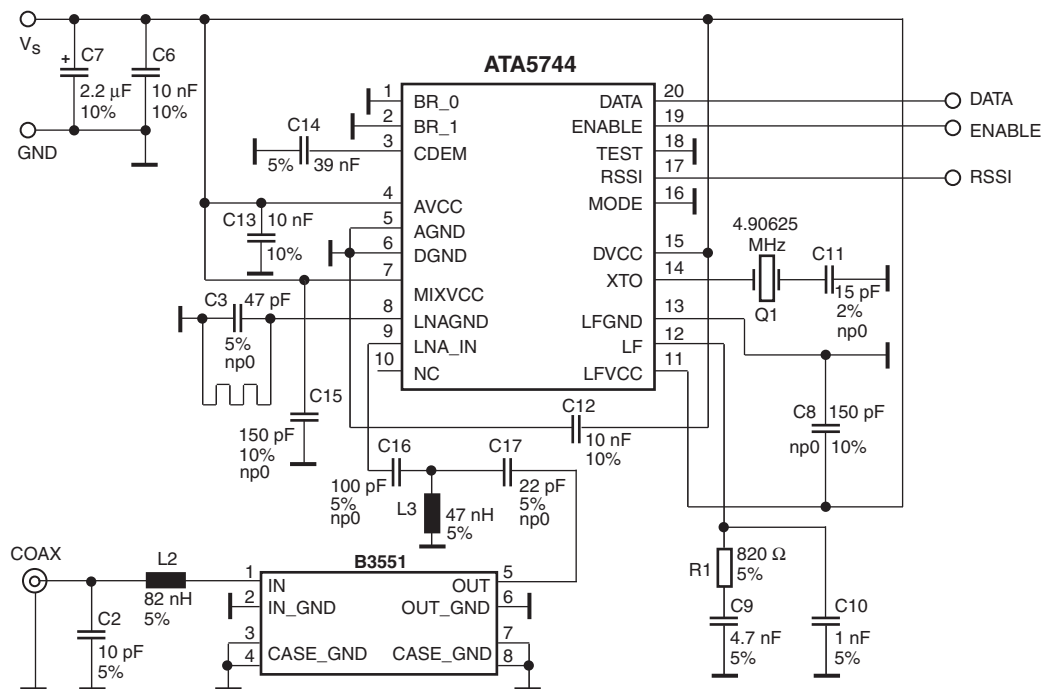

Figure 10-4. Application Circuit:  $f_{RF} = 315$  MHz, with SAW Filter



## 11. Ordering Information

Extended Type Number	Package	Remarks
ATA5744N-TKSY	SSO20	Tube, Pb-free
ATA5744N-TKQY	SSO20	Taped and reeled, Pb-free
ATA5744N-TGSY	SO20	Tube, Pb-free
ATA5744N-TGQY	SO20	Taped and reeled, Pb-free

## 12. Package Information

### Package SO20

Dimensions in mm

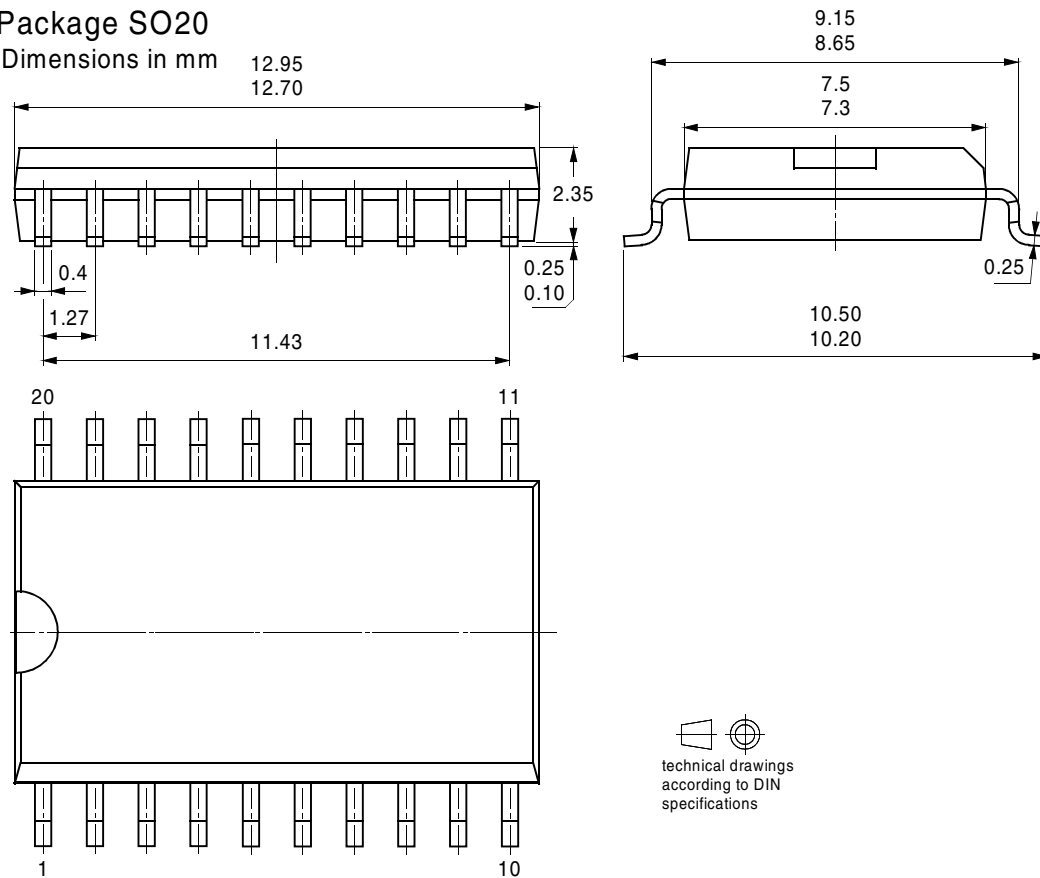

Package SSO20

Dimensions in mm

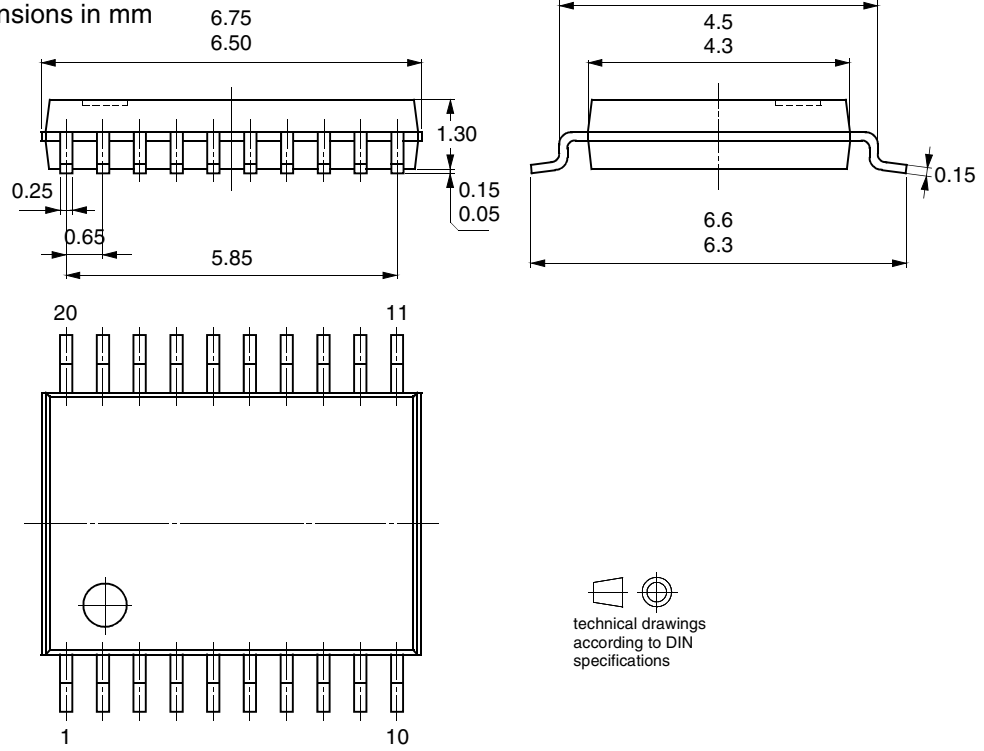

  
technical drawings  
according to DIN  
specifications



## Atmel Corporation

2325 Orchard Parkway  
San Jose, CA 95131, USA  
Tel: 1(408) 441-0311  
Fax: 1(408) 487-2600

## Regional Headquarters

### Europe

Atmel Sarl  
Route des Arsenaux 41  
Case Postale 80  
CH-1705 Fribourg  
Switzerland  
Tel: (41) 26-426-5555  
Fax: (41) 26-426-5500

### Asia

Room 1219  
Chinachem Golden Plaza  
77 Mody Road Tsimshatsui  
East Kowloon  
Hong Kong  
Tel: (852) 2721-9778  
Fax: (852) 2722-1369

### Japan

9F, Tonetsu Shinkawa Bldg.  
1-24-8 Shinkawa  
Chuo-ku, Tokyo 104-0033  
Japan  
Tel: (81) 3-3523-3551  
Fax: (81) 3-3523-7581

## Atmel Operations

### Memory

2325 Orchard Parkway  
San Jose, CA 95131, USA  
Tel: 1(408) 441-0311  
Fax: 1(408) 436-4314

### Microcontrollers

2325 Orchard Parkway  
San Jose, CA 95131, USA  
Tel: 1(408) 441-0311  
Fax: 1(408) 436-4314

La Chantrerie  
BP 70602  
44306 Nantes Cedex 3, France  
Tel: (33) 2-40-18-18-18  
Fax: (33) 2-40-18-19-60

### ASIC/ASSP/Smart Cards

Zone Industrielle  
13106 Rousset Cedex, France  
Tel: (33) 4-42-53-60-00  
Fax: (33) 4-42-53-60-01

1150 East Cheyenne Mtn. Blvd.  
Colorado Springs, CO 80906, USA  
Tel: 1(719) 576-3300  
Fax: 1(719) 540-1759

Scottish Enterprise Technology Park  
Maxwell Building  
East Kilbride G75 0QR, Scotland  
Tel: (44) 1355-803-000  
Fax: (44) 1355-242-743

### RF/Automotive

Theresienstrasse 2  
Postfach 3535  
74025 Heilbronn, Germany  
Tel: (49) 71-31-67-0  
Fax: (49) 71-31-67-2340

1150 East Cheyenne Mtn. Blvd.  
Colorado Springs, CO 80906, USA  
Tel: 1(719) 576-3300  
Fax: 1(719) 540-1759

### Biometrics/Imaging/Hi-Rel MPU/ High Speed Converters/RF Datacom

Avenue de Rochepleine  
BP 123  
38521 Saint-Egreve Cedex, France  
Tel: (33) 4-76-58-30-00  
Fax: (33) 4-76-58-34-80

---

## Literature Requests

[www.atmel.com/literature](http://www.atmel.com/literature)

**Disclaimer:** The information in this document is provided in connection with Atmel products. No license, express or implied, by estoppel or otherwise, to any intellectual property right is granted by this document or in connection with the sale of Atmel products. **EXCEPT AS SET FORTH IN ATMEL'S TERMS AND CONDITIONS OF SALE LOCATED ON ATMEL'S WEB SITE, ATMEL ASSUMES NO LIABILITY WHATSOEVER AND DISCLAIMS ANY EXPRESS, IMPLIED OR STATUTORY WARRANTY RELATING TO ITS PRODUCTS INCLUDING, BUT NOT LIMITED TO, THE IMPLIED WARRANTY OF MERCHANTABILITY, FITNESS FOR A PARTICULAR PURPOSE, OR NON-INFRINGEMENT. IN NO EVENT SHALL ATMEL BE LIABLE FOR ANY DIRECT, INDIRECT, CONSEQUENTIAL, PUNITIVE, SPECIAL OR INCIDENTAL DAMAGES (INCLUDING, WITHOUT LIMITATION, DAMAGES FOR LOSS OF PROFITS, BUSINESS INTERRUPTION, OR LOSS OF INFORMATION) ARISING OUT OF THE USE OR INABILITY TO USE THIS DOCUMENT, EVEN IF ATMEL HAS BEEN ADVISED OF THE POSSIBILITY OF SUCH DAMAGES.** Atmel makes no representations or warranties with respect to the accuracy or completeness of the contents of this document and reserves the right to make changes to specifications and product descriptions at any time without notice. Atmel does not make any commitment to update the information contained herein. Unless specifically provided otherwise, Atmel products are not suitable for, and shall not be used in, automotive applications. Atmel's products are not intended, authorized, or warranted for use as components in applications intended to support or sustain life.

© Atmel Corporation 2005. All rights reserved. Atmel®, logo and combinations thereof, Everywhere You Are® and others, are registered trademarks or trademarks of Atmel Corporation or its subsidiaries. Other terms and product names may be trademarks of others.



Printed on recycled paper.

## Looking for pricing, stock, or lifecycle information?

Click below to explore more details on WIN SOURCE:

 [View ATA5744N-TKQY 19 on WIN SOURCE](#)

 [Atmel Information](#)

## Optimize Your Supply Chain with WIN SOURCE Solutions

-  Global Sourcing Solution
-  Obsolete Management
-  Cost Control Management
-  Shortage Management
-  Alternative Solution
-  Excess Inventory Management