



**THE DATASHEET OF
AD5512AACPZ-REEL7**



FEATURES

- 12-/16-bit resolution
- 1 LSB INL
- 11.8 nV/√Hz noise spectral density
- 1 μs settling time
- 1.1 nV-sec glitch energy
- 0.05 ppm/°C temperature drift
- 5 kV HBM ESD classification
- 0.375 mW power consumption at 3 V
- 2.7 V to 5.5 V single-supply operation
- Hardware CLR and LDAC functions
- 50 MHz SPI-/QSPI-/MICROWIRE-/DSP-compatible interface
- Power-on reset clears DAC output to midscale
- Available in 3 mm × 3 mm, 10-/16-lead LFCSP and 16-lead TSSOP

APPLICATIONS

- Automatic test equipment
- Precision source-measure instruments
- Data acquisition systems
- Medical and aerospace instrumentation
- Communication equipment

GENERAL DESCRIPTION

The AD5512A/AD5542A are single, 12-/16-bit, serial input, unbuffered voltage output digital-to-analog converters (DAC) that operate from a single 2.7 V to 5.5 V supply. The DAC output range extends from 0 V to V_{REF} and is guaranteed monotonic, providing 1 LSB INL accuracy at 16 bits without adjustment over the full specified temperature range of -40°C to $+85^{\circ}\text{C}$ (AD5542A) or -40°C to $+125^{\circ}\text{C}$ (AD5512A).

Offering unbuffered outputs, the AD5512A/AD5542A achieve a 1 μs settling time with low offset errors ideal for high speed open loop control.

The AD5512A/AD5542A incorporate a bipolar mode of operation that generates a $\pm V_{REF}$ output swing. The AD5512A/AD5542A also include Kelvin sense connections for the reference and analog ground pins to reduce layout sensitivity.

The AD5512A/AD5542A are available in a 16-lead LFCSP with the AD5542A also available in a 10-lead LFCSP and a 16-lead TSSOP. The AD5512A/AD5542A use a versatile 3-wire interface that is compatible with 50 MHz SPI, QSPI™, MICROWIRE™, and DSP interface standards.

Rev. C

Document Feedback

Information furnished by Analog Devices is believed to be accurate and reliable. However, no responsibility is assumed by Analog Devices for its use, nor for any infringements of patents or other rights of third parties that may result from its use. Specifications subject to change without notice. No license is granted by implication or otherwise under any patent or patent rights of Analog Devices. Trademarks and registered trademarks are the property of their respective owners.

FUNCTIONAL BLOCK DIAGRAM

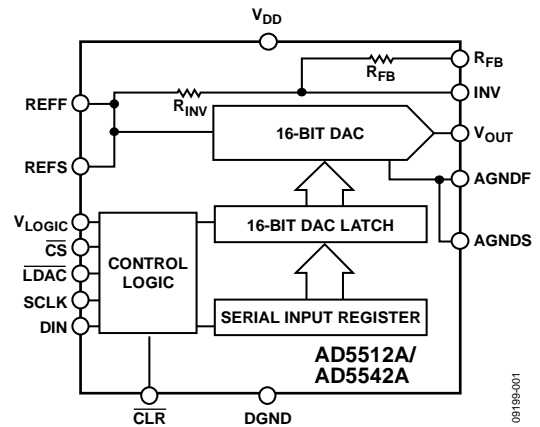

Figure 1. 16-Lead TSSOP and 16-Lead LFCSP

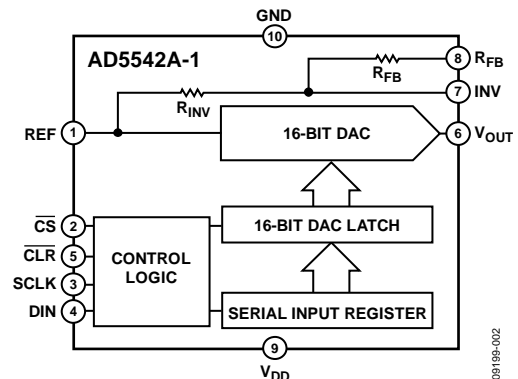

Figure 2. 10-Lead LFCSP

Table 1. Related Devices

| Part No. | Description |
|---------------|---|
| AD5040/AD5060 | 2.7 V to 5.5 V 14-/16-bit buffed output DACs |
| AD5541/AD5542 | 2.7 V to 5.5 V 16-bit voltage output DACs |
| AD5781/AD5791 | 18-/20-bit voltage output DACs |
| AD5570 | 16-bit $\pm 12\text{ V}/\pm 15\text{ V}$ bipolar output DAC |
| AD5024/AD5064 | 4.5 V to 5.5 V, 12-/16-bit quad channel DAC |
| AD5764 | 16-bit, bipolar, voltage output DAC |

PRODUCT HIGHLIGHTS

1. 16-bit performance without adjustment.
2. 2.7 V to 5.5 V single supply operation.
3. Low 11.8 nV/√Hz noise spectral density.
4. Low 0.05 ppm/°C temperature drift.
5. 3 mm × 3 mm LFCSP and TSSOP packaging.

TABLE OF CONTENTS

| | | | |
|--|----|---|----|
| Features | 1 | Unipolar Output Operation..... | 15 |
| Applications..... | 1 | Bipolar Output Operation..... | 16 |
| General Description | 1 | Output Amplifier Selection..... | 17 |
| Functional Block Diagram | 1 | Force Sense Amplifier Selection..... | 17 |
| Product Highlights | 1 | Reference and Ground..... | 17 |
| Revision History | 2 | Power-On Reset | 17 |
| Specifications..... | 3 | Power Supply and Reference Bypassing | 17 |
| AD5512A..... | 3 | Applications Information | 18 |
| AD5542A..... | 4 | Microprocessor Interfacing..... | 18 |
| AC Characteristics..... | 5 | AD5512A/AD5542A to ADSP-BF531 Interface | 18 |
| Timing Characteristics | 6 | AD5512A/AD5542A to SPORT Interface | 18 |
| Absolute Maximum Ratings..... | 7 | AD5512A/AD5542A to 68HC11/68L11 Interface | 18 |
| ESD Caution..... | 7 | AD5512A/AD5542A to MICROWIRE Interface | 18 |
| Pin Configuration and Function Descriptions..... | 8 | Layout Guidelines..... | 19 |
| Typical Performance Characteristics | 10 | Galvanically Isolated Interface | 19 |
| Terminology | 14 | Decoding Multiple DACs..... | 19 |
| Theory of Operation | 15 | Outline Dimensions | 20 |
| Digital-to-Analog Section | 15 | Ordering Guide | 21 |
| Serial Interface | 15 | | |

REVISION HISTORY

2/2017—Rev. B to Rev. C

| | |
|---------------------------------------|---|
| Changes to Figure 4 and Table 7 | 8 |
|---------------------------------------|---|

4/2015—Rev. A to Rev. B

| | |
|--|----|
| Changes to Power-On Reset Section..... | 17 |
| Deleted AD5512A/AD5542A to ADSP-2101 Interface Section.. | 18 |
| Updated Outline Dimensions | 20 |
| Changes to Ordering Guide | 21 |

5/2011—Rev. 0 to Rev. A

| | |
|--|----|
| Changes to Table 3, Power Dissipation Value and Endnote 1 | 4 |
| Changes to Table 5..... | 6 |
| Changes to Ordering Guide | 21 |

10/2010—Revision 0: Initial Version

SPECIFICATIONS

AD5512A

$V_{DD} = 2.7\text{ V to }5.5\text{ V}$, $V_{LOGIC} = 2.7\text{ V to }5.5\text{ V}$, $V_{REF} = 2.5\text{ V}$, $AGND = DGND = 0\text{ V}$, $-40^{\circ}\text{C} < T_A < +125^{\circ}\text{C}$, unless otherwise noted.

Table 2.

| Parameter ¹ | Min | Typ | Max | Unit | Test Condition |
|--|-----------------|------------|---|--------------------------|--|
| STATIC PERFORMANCE | | | | | |
| Resolution | 12 | | | Bits | Guaranteed monotonic R_{FB}/R_{INV} , typically $R_{FB} = R_{INV} = 28\text{ k}\Omega$ Ratio error |
| Relative Accuracy (INL) | | ± 0.5 | ± 1.0 | LSB | |
| Differential Nonlinearity (DNL) | | ± 0.5 | ± 1.0 | LSB | |
| Gain Error | | $+0.5$ | ± 2 | LSB | |
| Gain Error Temperature Coefficient | | ± 0.1 | | ppm/ $^{\circ}\text{C}$ | |
| Unipolar Zero-Code Error | | 0.03 | ± 0.5 | LSB | |
| Unipolar Zero-Code Temperature Coefficient | | ± 0.05 | | ppm/ $^{\circ}\text{C}$ | |
| Bipolar Resistor Matching | | 1 | | Ω/Ω | |
| | | ± 0.02 | ± 0.08 | % | |
| Bipolar Zero Offset Error | | ± 0.07 | ± 2 | LSB | |
| Bipolar Zero Temperature Coefficient | | ± 0.2 | | ppm/ $^{\circ}\text{C}$ | |
| Bipolar Zero-Code Offset Error | | ± 0.02 | ± 0.5 | LSB | |
| Bipolar Gain Error | | ± 0.07 | ± 2 | LSB | |
| Bipolar Gain Temperature Coefficient | | ± 0.1 | | ppm/ $^{\circ}\text{C}$ | |
| OUTPUT CHARACTERISTICS | | | | | |
| Output Voltage Range | 0 $-V_{REF}$ | | $V_{REF} - 1\text{ LSB}$ $+V_{REF} - 1\text{ LSB}$ | V V | Unipolar operation Bipolar operation |
| DAC Output Impedance | | 6.25 | | k Ω | Tolerance typically 20% |
| Power Supply Rejection Ratio | | | ± 1.0 | LSB | $\Delta V_{DD} \pm 10\%$ |
| Output Noise Spectral Density | | 11.8 | | nV/ $\sqrt{\text{Hz}}$ | DAC code = 0x840 (AD5512A) or 0x8400 (AD5542A), frequency = 1 kHz, unipolar mode |
| Output Noise | | 0.134 | | $\mu\text{V p-p}$ | 0.1 Hz to 10 Hz, unipolar mode |
| DAC REFERENCE INPUT ² | | | | | |
| Reference Input Range | 2.0 | | V_{DD} | V | Unipolar operation Bipolar operation Code 0x0000 Code 0x3FFF |
| Reference Input Resistance ³ | 9 7.5 | | | k Ω k Ω | |
| Reference Input Capacitance | | 26 26 | | pF pF | |
| | | | | | |
| LOGIC INPUTS | | | | | |
| Input Current | | | ± 1 | μA | $V_{DD} = 2.7\text{ V to }5.5\text{ V}$ $V_{DD} = 2.7\text{ V to }5.5\text{ V}$ |
| Input Low Voltage, V_{INL} | | | 0.8 | V | |
| Input High Voltage, V_{INH} | 2.4 | | | V | |
| Input Capacitance ² | | | 10 | pF | |
| Hysteresis Voltage ² | | 0.15 | | V | |
| POWER REQUIREMENTS | | | | | |
| V_{DD} | 2.7 | | 5.5 | V | All digital inputs at 0 V, V_{LOGIC} , or V_{DD} $V_{IH} = V_{LOGIC}$ or V_{DD} and $V_{IL} = \text{GND}$ |
| I_{DD} | | 125 | 150 | μA | |
| V_{LOGIC} | 1.8 | | 5.5 | V | All digital inputs at 0 V, V_{LOGIC} , or V_{DD} |
| I_{LOGIC} | | 15 | 24 | μA | |
| Power Dissipation | | 1.5 | 6.05 | mW | |

¹ Temperatures are as follows: A version -40°C to $+125^{\circ}\text{C}$.

² Guaranteed by design, not subject to production test.

³ Reference input resistance is code-dependent, minimum at 0x855.

AD5542A

$V_{DD} = 2.7\text{ V}$ to 5.5 V , $V_{LOGIC} = 2.7\text{ V}$ to 5.5 V , $V_{REF} = 2.5\text{ V}$, $AGND = DGND = 0\text{ V}$, $-40^{\circ}\text{C} < T_A < +85^{\circ}\text{C}$, unless otherwise noted.

Table 3.

| Parameter ¹ | Min | Typ | Max | Unit | Test Condition |
|--|-----------------|--------------|---|-------------------------|--|
| STATIC PERFORMANCE | | | | | |
| Resolution | 16 | | | Bits | |
| Relative Accuracy (INL) | | ± 0.5 | ± 1.0 | LSB | B grade |
| | | | ± 2.0 | | A grade |
| Differential Nonlinearity (DNL) | | ± 0.5 | ± 1.0 | LSB | Guaranteed monotonic |
| Gain Error | | $+0.5$ | ± 2 | LSB | $T_A = 25^{\circ}\text{C}$ |
| | | | ± 3 | LSB | |
| Gain Error Temperature Coefficient | | ± 0.1 | | ppm/ $^{\circ}\text{C}$ | |
| Unipolar Zero-Code Error | | 0.3 | ± 0.7 | LSB | $T_A = 25^{\circ}\text{C}$ |
| | | | ± 1.5 | LSB | |
| Unipolar Zero-Code Temperature Coefficient | | ± 0.05 | | ppm/ $^{\circ}\text{C}$ | |
| Bipolar Resistor Matching | | 1.000 | | Ω/Ω | R_{FB}/R_{INV} , typically $R_{FB} = R_{INV} = 28\text{ k}\Omega$ |
| | | ± 0.0015 | ± 0.0076 | % | Ratio error |
| Bipolar Zero Offset Error | | ± 1 | ± 5 | LSB | $T_A = 25^{\circ}\text{C}$ |
| | | | ± 6 | LSB | |
| Bipolar Zero Temperature Coefficient | | ± 0.2 | | ppm/ $^{\circ}\text{C}$ | |
| Bipolar Zero-Code Offset Error | | ± 1 | ± 5 | LSB | $T_A = 25^{\circ}\text{C}$ |
| | | | ± 6 | LSB | |
| Bipolar Gain Error | | ± 1 | ± 5 | LSB | $T_A = 25^{\circ}\text{C}$ |
| | | | ± 6 | LSB | |
| Bipolar Gain Temperature Coefficient | | ± 0.1 | | ppm/ $^{\circ}\text{C}$ | |
| OUTPUT CHARACTERISTICS | | | | | |
| Output Voltage Range | 0 $-V_{REF}$ | | $V_{REF} - 1\text{ LSB}$ $+V_{REF} - 1\text{ LSB}$ | V V | Unipolar operation Bipolar operation |
| DAC Output Impedance | | 6.25 | | k Ω | Tolerance typically 20% |
| Power Supply Rejection Ratio | | | ± 1.0 | LSB | $\Delta V_{DD} \pm 10\%$ |
| Output Noise Spectral Density | | 11.8 | | nV/ $\sqrt{\text{Hz}}$ | DAC code = 0x840 (AD5512A) or 0x8400 (AD5542A), frequency = 1 kHz, unipolar mode |
| Output Noise | | 0.134 | | $\mu\text{V p-p}$ | 0.1 Hz to 10 Hz |
| DAC REFERENCE INPUT ² | | | | | |
| Reference Input Range | 2.0 | | V_{DD} | V | |
| Reference Input Resistance ³ | 9 | | | k Ω | Unipolar operation |
| | 7.5 | | | k Ω | Bipolar operation |
| Reference Input Capacitance | | 26 | | pF | Code 0x0000 |
| | | 26 | | pF | Code 0xFFFF |
| LOGIC INPUTS | | | | | |
| Input Current | | | ± 1 | μA | |
| Input Low Voltage, V_{INL} | | | 0.8 | V | $V_{DD} = 2.7\text{ V}$ to 5.5 V |
| Input High Voltage, V_{INH} | 2.4 | | | V | $V_{DD} = 2.7\text{ V}$ to 5.5 V |
| Input Capacitance ² | | | 10 | pF | |
| Hysteresis Voltage ² | | 0.15 | | V | |
| POWER REQUIREMENTS | | | | | |
| V_{DD} | 2.7 | | 5.5 | V | All digital inputs at 0 V, V_{LOGIC} , or V_{DD} |
| I_{DD} | | 125 | 150 | μA | $V_{IH} = V_{LOGIC}$ or V_{DD} and $V_{IL} = \text{GND}$ |
| V_{LOGIC} | 1.8 | | 5.5 | V | |
| I_{LOGIC} | | 15 | 24 | μA | All digital inputs at 0 V, V_{LOGIC} , or V_{DD} |
| Power Dissipation | | 0.625 | 0.825 | mW | |

¹ For $2.7\text{ V} \leq V_{LOGIC} \leq 5.5\text{ V}$, temperatures are as follows: A, B versions -40°C to $+85^{\circ}\text{C}$.

² Guaranteed by design, not subject to production test.

³ Reference input resistance is code-dependent, minimum at 0x8555.

AC CHARACTERISTICS

$V_{DD} = 2.7\text{ V to }5.5\text{ V}$, $V_{LOGIC} = 2.7\text{ V to }5.5\text{ V}$, $2.5\text{ V} \leq V_{REF} \leq V_{DD}$, $AGND = DGND = 0\text{ V}$, $-40^{\circ}\text{C} < T_A < +125^{\circ}\text{C}$, unless otherwise noted.

Table 4.

| Parameter | Min | Typ | Max | Unit | Test Condition |
|----------------------------------|-----|-----|-----|----------------------------|---|
| Output Voltage Settling Time | | 1 | | μs | To 1/2 LSB of FS, $C_L = 10\text{ pF}$ |
| Slew Rate | | 17 | | $\text{V}/\mu\text{s}$ | $C_L = 10\text{ pF}$, measured from 0% to 63% |
| Digital-to-Analog Glitch Impulse | | 1.1 | | $\text{nV}\cdot\text{sec}$ | 1 LSB change around major carry |
| Reference -3 dB Bandwidth | | 2.2 | | MHz | All 1s loaded |
| Reference Feedthrough | | 1 | | mV p-p | All 0s loaded, $V_{REF} = 1\text{ V p-p}$ at 100 kHz |
| Digital Feedthrough | | 0.2 | | $\text{nV}\cdot\text{sec}$ | |
| Signal-to-Noise Ratio | | 92 | | dB | |
| Spurious Free Dynamic Range | | 80 | | dB | Digitally generated sine wave at 1 kHz |
| Total Harmonic Distortion | | 74 | | dB | DAC code = 0x3FFF (AD5512A) or 0xFFFF (AD5542A), frequency 10 kHz, $V_{REF} = 2.5\text{ V} \pm 1\text{ V p-p}$ |

TIMING CHARACTERISTICS

$V_{DD} = 5\text{ V}$, $2.5\text{ V} \leq V_{REF} \leq V_{DD}$, $V_{INH} = 90\%$ of V_{LOGIC} , $V_{INL} = 10\%$ of V_{LOGIC} , $AGND = DGND = 0\text{ V}$, unless otherwise noted.

Table 5.

| Parameter ^{1,2} | Limit $1.8 \leq V_{LOGIC} \leq 2.7\text{ V}$ ³ | Limit $2.7\text{ V} \leq V_{LOGIC} \leq 5.5\text{ V}$ ⁴ | Unit | Description |
|--------------------------|---|--|---------|--|
| f_{SCLK} | 14 | 50 | MHz max | SCLK cycle frequency |
| t_1 | 70 | 20 | ns min | SCLK cycle time |
| t_2 | 35 | 10 | ns min | SCLK high time |
| t_3 | 35 | 10 | ns min | SCLK low time |
| t_4 | 5 | 5 | ns min | \overline{CS} low to SCLK high setup |
| t_5 | 5 | 5 | ns min | \overline{CS} high to SCLK high setup |
| t_6 | 5 | 5 | ns min | SCLK high to \overline{CS} low hold time |
| t_7 | 10 | 5 | ns min | SCLK high to \overline{CS} high hold time |
| t_8 | 35 | 10 | ns min | Data setup time |
| t_9 | 5 | 4 | ns min | Data hold time ($V_{INH} = 90\%$ of V_{DD} , $V_{INL} = 10\%$ of V_{DD}) |
| t_9 | 5 | 5 | ns min | Data hold time ($V_{INH} = 3\text{ V}$, $V_{INL} = 0\text{ V}$) |
| t_{10} | 20 | 20 | ns min | \overline{LDAC} pulsewidth |
| t_{11} | 10 | 10 | ns min | \overline{CS} high to \overline{LDAC} low setup |
| t_{12} | 15 | 15 | ns min | \overline{CS} high time between active periods |
| t_{13} | 15 | 15 | ns | \overline{CLR} pulsewidth |

¹ Guaranteed by design and characterization, not production tested.

² All input signals are specified with $t_R = t_F = 1\text{ ns/V}$ and timed from a voltage level of $(V_{INL} + V_{INH})/2$.

³ $-40^\circ\text{C} < T_A < +105^\circ\text{C}$.

⁴ $-40^\circ\text{C} < T_A < +125^\circ\text{C}$.

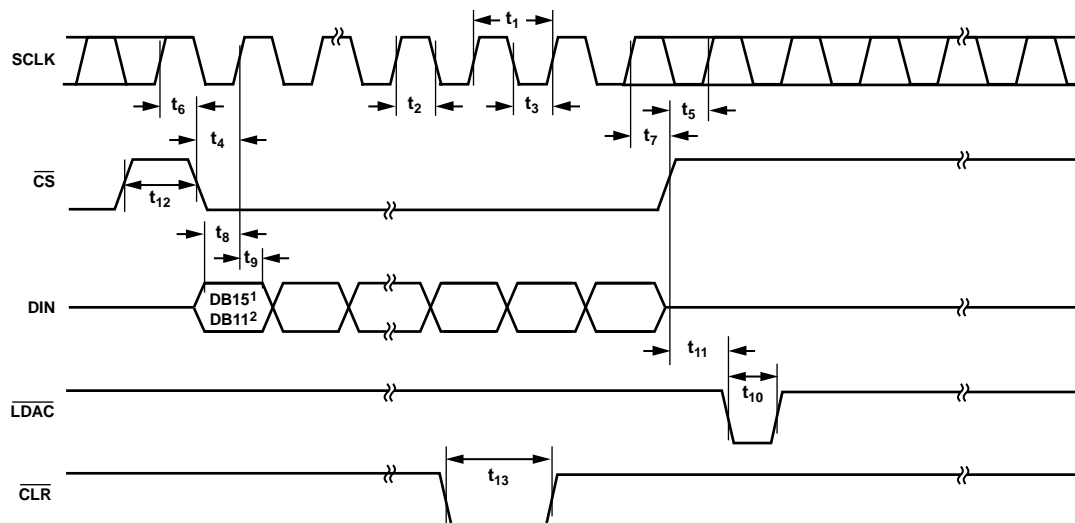

NOTES
 1. FOR AD5542A = DB15.
 2. FOR AD5512A = DB11.

Figure 3. Timing Diagram

09199-003

ABSOLUTE MAXIMUM RATINGS

$T_A = 25^\circ\text{C}$, unless otherwise noted.

Table 6.

| Parameter | Rating |
|---|---------------------------------------|
| V_{DD} to AGND | -0.3 V to +6 V |
| Digital Input Voltage to DGND | -0.3 V to $V_{DD} + 0.3$ V |
| V_{OUT} to AGND | -0.3 V to $V_{DD} + 0.3$ V |
| AGNDF, AGNDS to DGND | -0.3 V to +0.3 V |
| Input Current to Any Pin Except Supplies | ± 10 mA |
| Operating Temperature Range | |
| AD5512A Industrial (A Version) | -40°C to +125°C |
| AD5542A Industrial (A, B Versions) | -40°C to +85°C |
| Storage Temperature Range | -65°C to +150°C |
| Maximum Junction Temperature (T_J max) | 150°C |
| Package Power Dissipation | $(T_J \text{ max} - T_A)/\theta_{JA}$ |
| Thermal Impedance, θ_{JA} | |
| TSSOP (RU-16) | 113°C/W |
| LFCSP (CP-16-22) | 73°C/W |
| LFCSP (CP-10-9) | 74°C/W |
| Lead Temperature, Soldering | |
| Peak Temperature ¹ | 260°C |
| ESD ² | 5 kV |

¹ As per JEDEC Standard 20.

² HBM classification.

Stresses at or above those listed under Absolute Maximum Ratings may cause permanent damage to the product. This is a stress rating only; functional operation of the product at these or any other conditions above those indicated in the operational section of this specification is not implied. Operation beyond the maximum operating conditions for extended periods may affect product reliability.

ESD CAUTION



ESD (electrostatic discharge) sensitive device. Charged devices and circuit boards can discharge without detection. Although this product features patented or proprietary protection circuitry, damage may occur on devices subjected to high energy ESD. Therefore, proper ESD precautions should be taken to avoid performance degradation or loss of functionality.

PIN CONFIGURATION AND FUNCTION DESCRIPTIONS

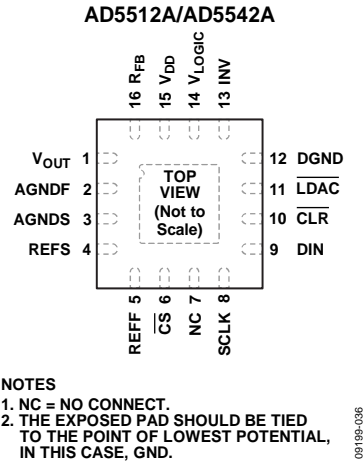

Figure 4. AD5512A/AD5542A 16-Lead LFCSP Pin Configuration

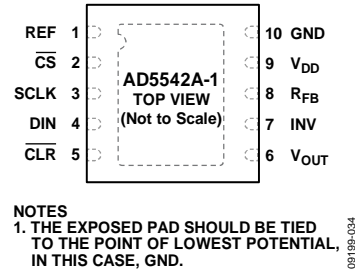

Figure 5. AD5542A-1 10-Lead LFCSP Pin Configuration

Table 7. AD5512A/AD5542A Pin Function Descriptions

| Pin No. | | Mnemonic | Description |
|---------------|---------------|--------------------|---|
| 16-Lead LFCSP | 10-Lead LFCSP | | |
| 1 | 6 | V _{OUT} | Analog Output Voltage from the DAC. |
| 2 | | AGNDF | Ground Reference Point for Analog Circuitry (Force). |
| 3 | | AGNDS | Ground Reference Point for Analog Circuitry (Sense). |
| 4 | | REFS | Voltage Reference Input (Sense) for the DAC. Connect to an external 2.5 V reference. Reference can range from 2 V to V _{DD} . |
| 5 | | REFF | Voltage Reference Input (Force) for the DAC. Connect to an external 2.5 V reference. Reference can range from 2 V to V _{DD} . |
| 6 | 2 | \overline{CS} | Logic Input Signal. The chip select signal is used to frame the serial data input. |
| 7 | | NC | No Connect. |
| 8 | 3 | SCLK | Clock Input. Data is clocked into the input register on the rising edge of SCLK. Duty cycle must be between 40% and 60%. |
| 9 | 4 | DIN | Serial Data Input. This device accepts 16-bit words. Data is clocked into the input register on the rising edge of SCLK. |
| 10 | 5 | \overline{CLR} | Asynchronous Clear Input. The \overline{CLR} input is falling edge sensitive. When \overline{CLR} is low, all \overline{LDAC} pulses are ignored. When \overline{CLR} is activated, the DAC register is cleared to the model selectable midscale. |
| 11 | | \overline{LDAC} | \overline{LDAC} Input. When this input is taken low, the DAC register is simultaneously updated with the contents of the input register. |
| 12 | | DGND | Digital Ground. Ground reference for digital circuitry. |
| 13 | 7 | INV | Connection to the Internal Scaling Resistors of the DAC. Connect the INV pin to the external op amps inverting input in bipolar mode. |
| 14 | | V _{LOGIC} | Logic Power Supply. |
| 15 | 9 | V _{DD} | Analog Supply Voltage, 5 V ± 10%. |
| 16 | 8 | R _{FB} | Feedback Resistor Pin. In bipolar mode, connect this pin to the external op amp output. |
| | 1 | REF | Voltage Reference Input for the DAC. Connect this pin to an external 2.5 V reference. Reference can range from 2 V to V _{DD} . |
| | 10 | GND | Ground. |
| EPAD | EPAD | Exposed Pad | The exposed pad should be tied to the point of lowest potential, in this case, GND. |

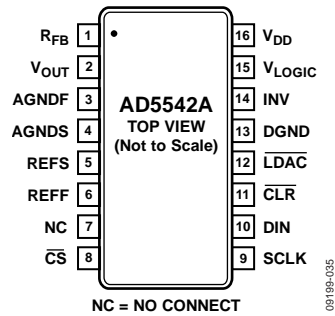

Figure 6. AD5542A 16-Lead TSSOP Pin Configuration

Table 8. AD5542A Pin Function Descriptions

| Pin No. | Mnemonic | Description |
|---------|--------------------------|---|
| 1 | R _{FB} | Feedback Resistor Pin. In bipolar mode, connect this pin to the external op amp output. |
| 2 | V _{OUT} | Analog Output Voltage from the DAC. |
| 3 | AGNDF | Ground Reference Point for Analog Circuitry (Force). |
| 4 | AGNDS | Ground Reference Point for Analog Circuitry (Sense). |
| 5 | REFS | Voltage Reference Input (Sense) for the DAC. Connect to an external 2.5 V reference. Reference can range from 2 V to V _{DD} . |
| 6 | REFF | Voltage Reference Input (Force) for the DAC. Connect to an external 2.5 V reference. Reference can range from 2 V to V _{DD} . |
| 7 | NC | No Connect. |
| 8 | $\overline{\text{CS}}$ | Logic Input Signal. The chip select signal is used to frame the serial data input. |
| 9 | SCLK | Clock Input. Data is clocked into the input register on the rising edge of SCLK. Duty cycle must be between 40% and 60%. |
| 10 | DIN | Serial Data Input. This device accepts 16-bit words. Data is clocked into the input register on the rising edge of SCLK. |
| 11 | $\overline{\text{CLR}}$ | Asynchronous Clear Input. The CLR input is falling edge sensitive. When CLR is low, all LDAC pulses are ignored. When $\overline{\text{CLR}}$ is activated, the DAC register is cleared to the model selectable midscale. |
| 12 | $\overline{\text{LDAC}}$ | LDAC Input. When this input is taken low, the DAC register is simultaneously updated with the contents of the input register. |
| 13 | DGND | Digital Ground. Ground reference for digital circuitry. |
| 14 | INV | Connection to the Internal Scaling Resistors of the DAC. Connect the INV pin to the external op amps inverting input in bipolar mode. |
| 15 | V _{LOGIC} | Logic Power Supply. |
| 16 | V _{DD} | Analog Supply Voltage, 5 V \pm 10%. |

TYPICAL PERFORMANCE CHARACTERISTICS

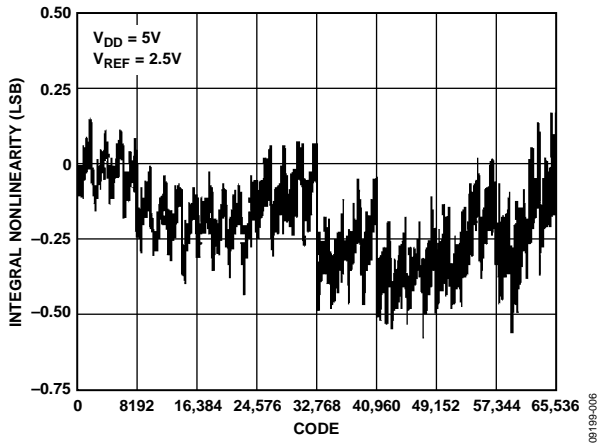

Figure 7. AD5542A Integral Nonlinearity vs. Code

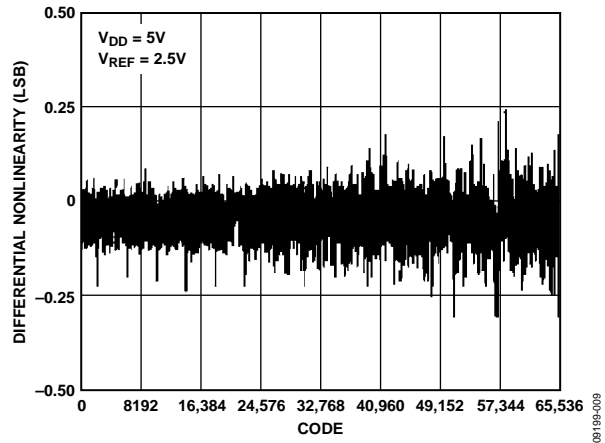

Figure 10. AD5542A Differential Nonlinearity vs. Code

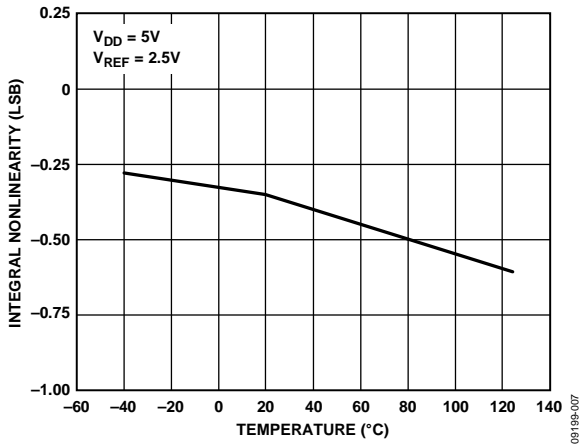

Figure 8. AD5542A Integral Nonlinearity vs. Temperature

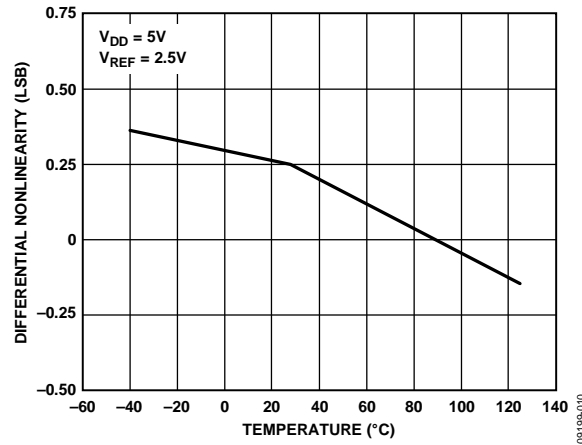

Figure 11. AD5542A Differential Nonlinearity vs. Temperature

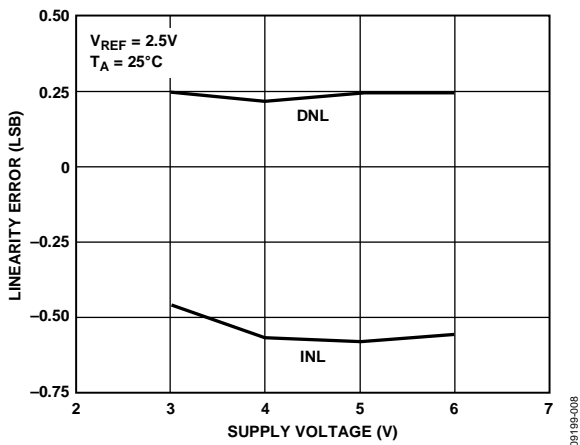

Figure 9. AD5542A Linearity Error vs. Supply Voltage

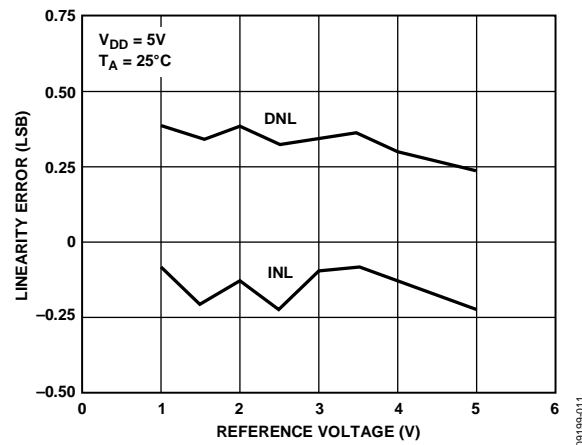

Figure 12. AD5542A Linearity Error vs. Reference Voltage

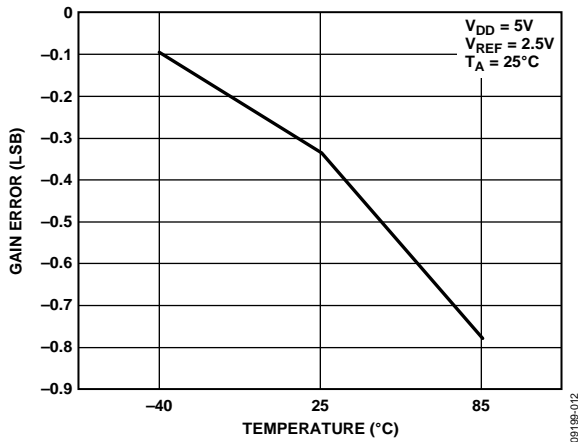

Figure 13. AD5512A/AD5542A Gain Error vs. Temperature

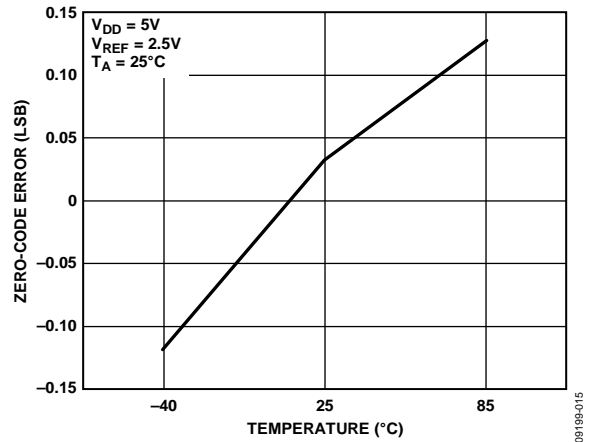

Figure 16. AD5512A/AD5542A Zero-Code Error vs. Temperature

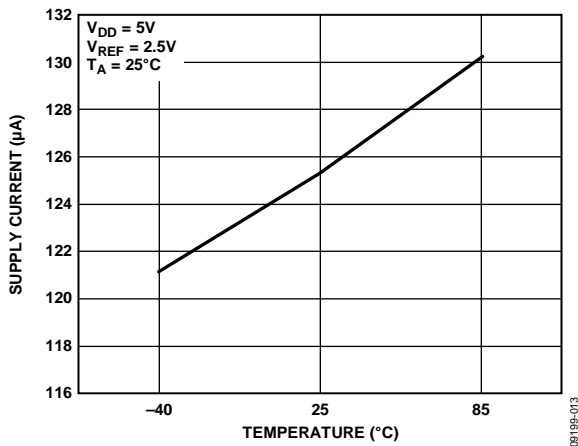

Figure 14. AD5512A/AD5542A Supply Current vs. Temperature

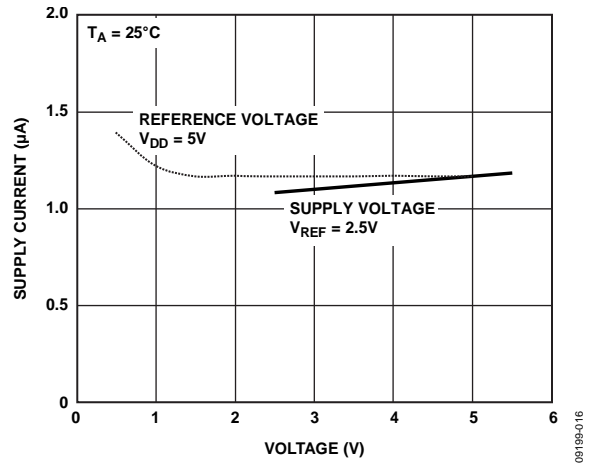

Figure 17. AD5512A/AD5542A Supply Current vs. Reference Voltage or Supply Voltage

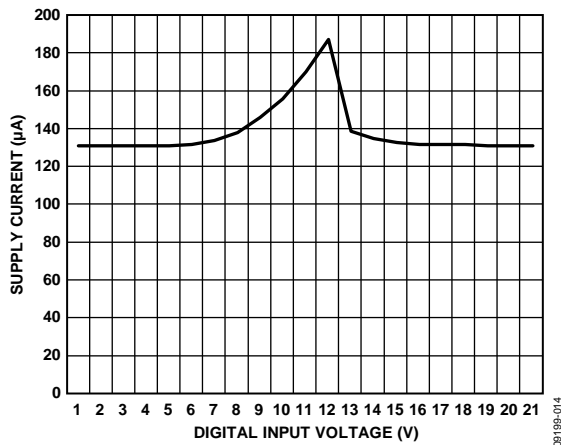

Figure 15. AD5512A/AD5542A Supply Current vs. Digital Input Voltage

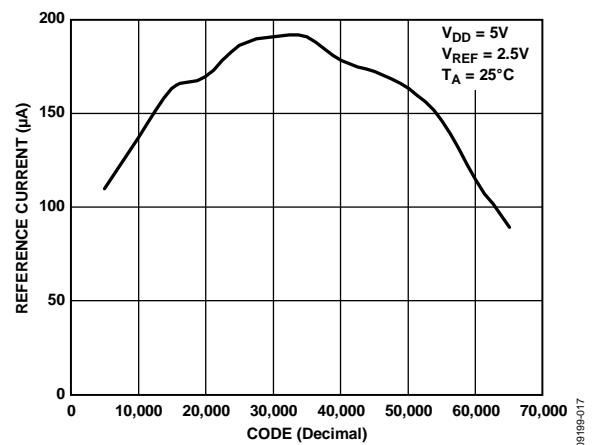

Figure 18. AD5512A/AD5542A Reference Current vs. Code

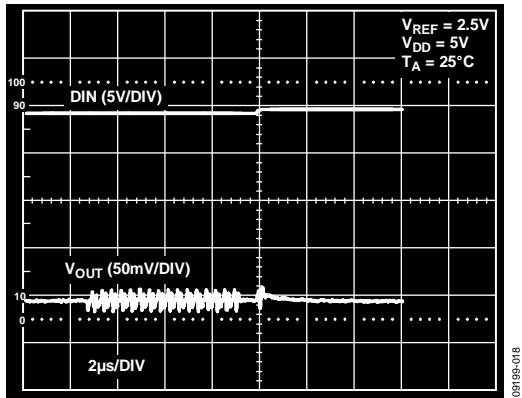

Figure 19. AD5512A/AD5542A Digital Feedthrough

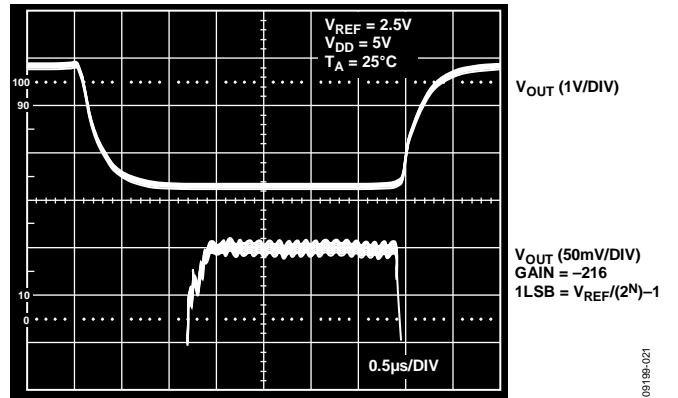

Figure 22. AD5512A/AD5542A Small Signal Settling Time

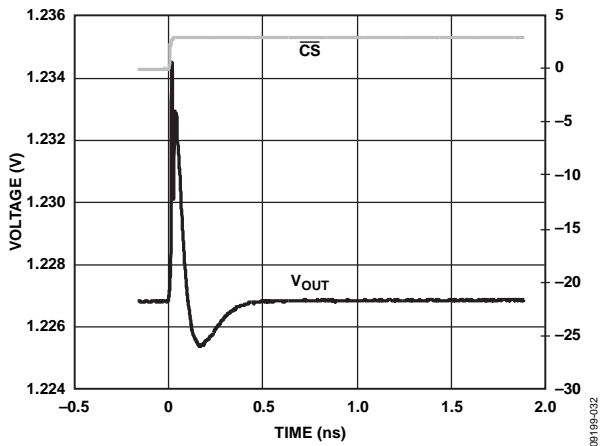

Figure 20. AD5512A/AD5542A Digital-to-Analog Glitch Impulse

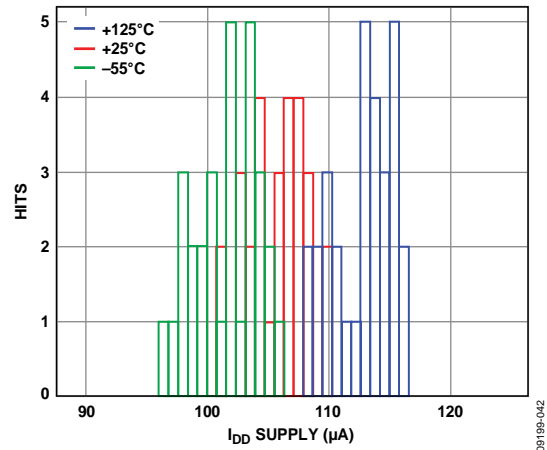

Figure 23. AD5512A/AD5542A Analog Supply Current Histogram

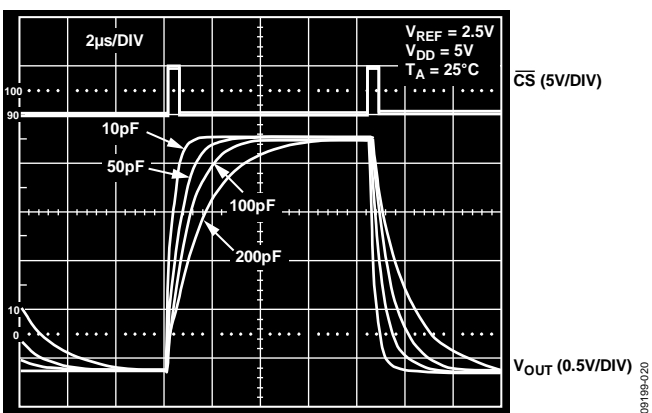

Figure 21. AD5512A/AD5542A Large Signal Settling Time

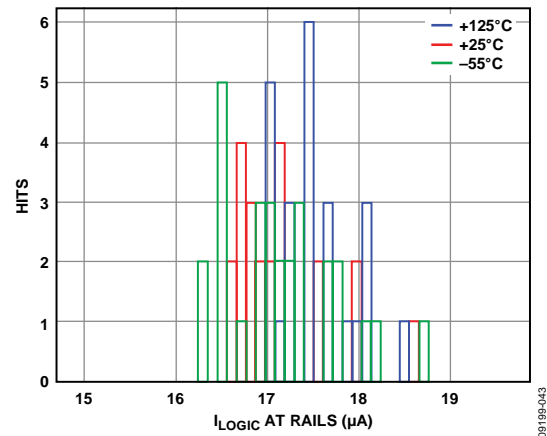

Figure 24. AD5512A/AD5542A Digital Supply Current Histogram

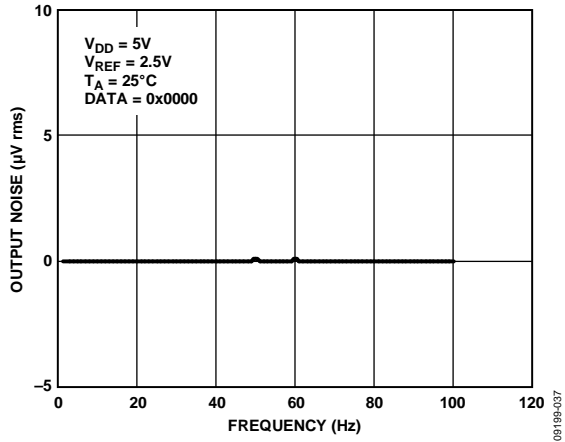

Figure 25. AD5512A/AD5542A 0.1 Hz to 10 Hz Output Noise

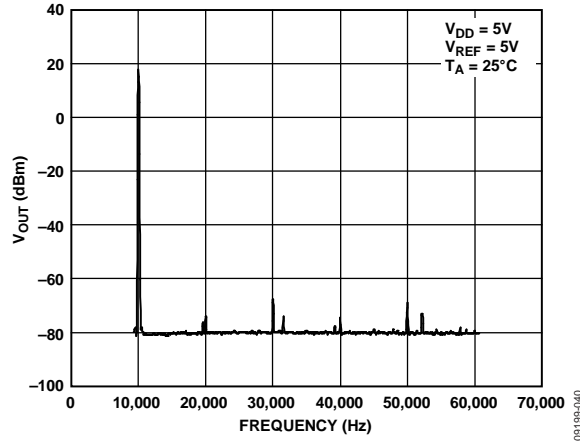

Figure 28. AD5512A/AD5542A Total Harmonic Distortion

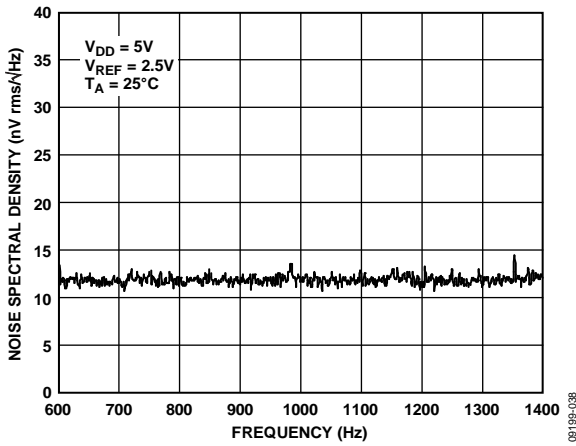

Figure 26. AD5512A/AD5542A Noise Spectral Density vs. Frequency, 1 kHz

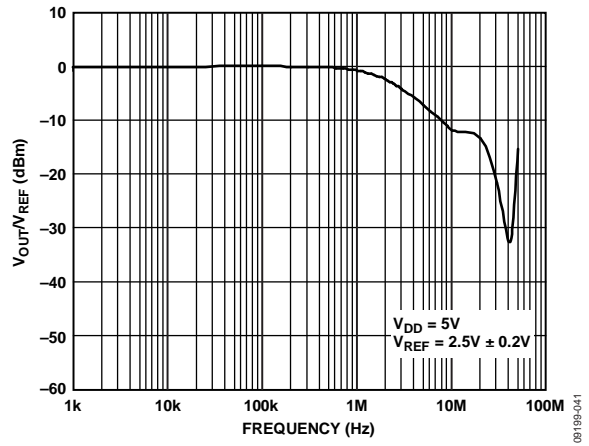

Figure 29. AD5512A/AD5542A Multiplying Bandwidth

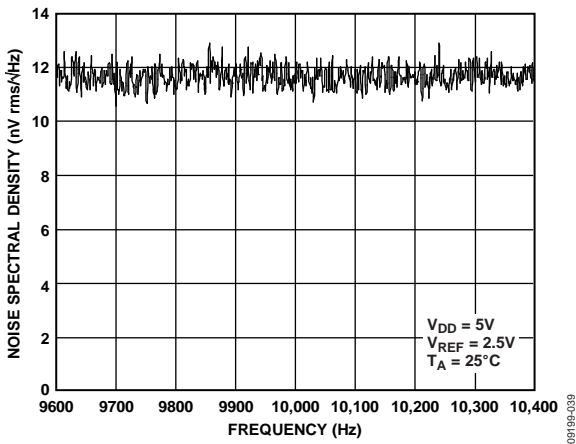

Figure 27. AD5512A/AD5542A Noise Spectral Density vs. Frequency, 10 kHz

TERMINOLOGY

Relative Accuracy or Integral Nonlinearity (INL)

For the DAC, relative accuracy or INL is a measure of the maximum deviation, in LSBs, from a straight line passing through the endpoints of the DAC transfer function. A typical INL vs. code plot is shown in Figure 7.

Differential Nonlinearity (DNL)

DNL is the difference between the measured change and the ideal 1 LSB change between any two adjacent codes. A specified differential nonlinearity of ± 1 LSB maximum ensures monotonicity. A typical DNL vs. code plot is shown in Figure 10.

Gain Error

Gain error is the difference between the actual and ideal analog output range, expressed as a percent of the full-scale range. It is the deviation in slope of the DAC transfer characteristic from ideal.

Gain Error Temperature Coefficient

Gain error temperature coefficient is a measure of the change in gain error with changes in temperature. It is expressed in ppm/ $^{\circ}$ C.

Zero-Code Error

Zero-code error is a measure of the output error when zero code is loaded to the DAC register.

Zero-Code Temperature Coefficient

This is a measure of the change in zero-code error with a change in temperature. It is expressed in mV/ $^{\circ}$ C.

Digital-to-Analog Glitch Impulse

Digital-to-analog glitch impulse is the impulse injected into the analog output when the input code in the DAC register changes state. It is normally specified as the area of the glitch in nV-sec and is measured when the digital input code is changed by 1 LSB at the major carry transition. A digital-to-analog glitch impulse plot is shown in Figure 20.

Digital Feedthrough

Digital feedthrough is a measure of the impulse injected into the analog output of the DAC from the digital inputs of the DAC, but it is measured when the DAC output is not updated. $\overline{\text{CS}}$ is held high while the SCLK and DIN signals are toggled. It is specified in nV-sec and is measured with a full-scale code change on the data bus, that is, from all 0s to all 1s and vice versa. A typical digital feedthrough plot is shown in Figure 19.

Power Supply Rejection Ratio (PSRR)

PSRR indicates how the output of the DAC is affected by changes in the power supply voltage. The power supply rejection ratio is quoted in terms of percent change in output per percent change in V_{DD} for full-scale output of the DAC. V_{DD} is varied by $\pm 10\%$.

Reference Feedthrough

Reference feedthrough is a measure of the feedthrough from the V_{REF} input to the DAC output when the DAC is loaded with all 0s. A 100 kHz, 1 V p-p is applied to V_{REF} . Reference feedthrough is expressed in mV p-p.

THEORY OF OPERATION

The AD5512A/AD5542A are single, 12-/16-bit, serial input, voltage output DACs. They operate from a single supply ranging from 2.7 V to 5 V and consume typically 125 μ A with a supply of 5 V. Data is written to these devices in a 12-bit (AD5512A) or 16-bit (AD5542A) word format, via a 3- or 4-wire serial interface. To ensure a known power-up state, these parts are designed with a power-on reset function. In unipolar mode, the output is reset to midscale; in bipolar mode, the output is set to 0 V. Kelvin sense connections for the reference and analog ground are included on the AD5512A/AD5542A.

DIGITAL-TO-ANALOG SECTION

The DAC architecture consists of two matched DAC sections. A simplified circuit diagram is shown in Figure 30. The DAC architecture of the AD5512A/AD5542A is segmented. The four MSBs of the 16-bit (AD5542A)/12-bit (AD5512A) data-word are decoded to drive 15 switches, E1 to E15. Each switch connects one of 15 matched resistors to either AGND or V_{REF} . The remaining 12 bits of the data-word drive the S0 to S11 switches of a 12-bit voltage mode R-2R ladder network.

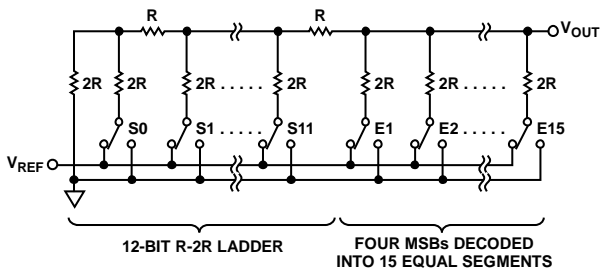

Figure 30. DAC Architecture

With this type of DAC configuration, the output impedance is independent of code, while the input impedance seen by the reference is heavily code dependent. The output voltage is dependent on the reference voltage, as shown in the following equation:

$$V_{OUT} = \frac{V_{REF} \times D}{2^N}$$

where:

D is the decimal data-word loaded to the DAC register.
 N is the resolution of the DAC.

For a reference of 2.5 V, the equation simplifies to the following:

$$V_{OUT} = \frac{2.5 \times D}{65,536}$$

This gives a V_{OUT} of 1.25 V with midscale loaded, and 2.5 V with full scale loaded to the DAC.

The LSB size is $V_{REF}/65,536$.

SERIAL INTERFACE

The AD5512A/AD5542A are controlled by a versatile 3- or 4-wire serial interface that operates at clock rates of up to 50 MHz and is compatible with SPI, QSPI, MICROWIRE, and DSP interface standards. The timing diagram is shown in Figure 3. Input data is framed by the chip select input, \overline{CS} . After a high-to-low transition on \overline{CS} , data is shifted synchronously and latched into the input register on the rising edge of the serial clock, SCLK. Data is loaded MSB first in 12-bit (AD5512A) or 16-bit (AD5542A) words. After 12 (AD5512A) or 16 (AD5542A) data bits have been loaded into the serial input register, a low-to-high transition on \overline{CS} transfers the contents of the shift register to the DAC. Data can be loaded to the part only while \overline{CS} is low.

The AD5512A/AD5542A have an \overline{LDAC} function that allows the DAC latch to be updated asynchronously by bringing \overline{LDAC} low after \overline{CS} goes high. \overline{LDAC} should be maintained high while data is written to the shift register. Alternatively, \overline{LDAC} can be tied permanently low to update the DAC synchronously. With \overline{LDAC} tied permanently low, the rising edge of \overline{CS} loads the data to the DAC.

UNIPOLAR OUTPUT OPERATION

These DACs are capable of driving unbuffered loads of 60 k Ω . Unbuffered operation results in low supply current, typically 300 μ A, and a low offset error. The AD5512A/AD5542A provide a unipolar output swing ranging from 0 V to V_{REF} . The AD5512A/AD5542A can be configured to output both unipolar and bipolar voltages. Figure 31 shows a typical unipolar output voltage circuit. The code table for this mode of operation is shown in Table 9.

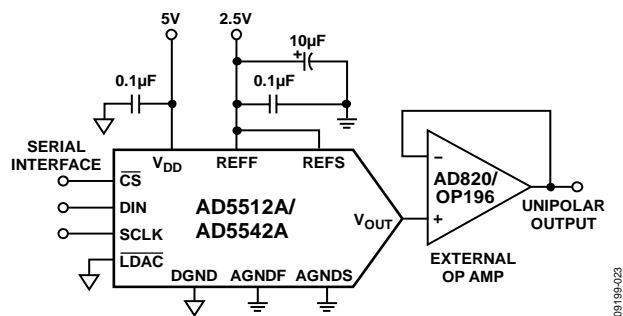

Figure 31. Unipolar Output

Table 9. AD5542A Unipolar Code Table

| DAC Latch Contents | | Analog Output |
|--------------------|----------------|--|
| MSB | LSB | |
| 1111 | 1111 1111 1111 | $V_{REF} \times (65,535/65,536)$ |
| 1000 | 0000 0000 0000 | $V_{REF} \times (32,768/65,536) = \frac{1}{2} V_{REF}$ |
| 0000 | 0000 0000 0001 | $V_{REF} \times (1/65,536)$ |
| 0000 | 0000 0000 0000 | 0 V |

Assuming a perfect reference, the unipolar worst-case output voltage can be calculated from the following equation:

$$V_{OUT-UNI} = \frac{D}{2^N} \times (V_{REF} + V_{GE}) + V_{ZSE} + INL$$

where:

$V_{OUT-UNI}$ is the unipolar mode worst-case output.

D is the code loaded to DAC.

N is the resolution of the DAC.

V_{REF} is the reference voltage applied to the part.

V_{GE} is the gain error in volts.

V_{ZSE} is the zero-scale error in volts.

INL is the integral nonlinearity in volts.

BIPOLAR OUTPUT OPERATION

With the aid of an external op amp, the AD5512A/AD5542A can be configured to provide a bipolar voltage output. A typical circuit is shown in Figure 32. The matched bipolar offset resistors, R_{FB} and R_{INV} , are connected to an external op amp to achieve this bipolar output swing, typically $R_{FB} = R_{INV} = 28 \text{ k}\Omega$. Table 10 shows the transfer function for this output operating mode. Also provided on the AD5542A are a set of Kelvin connections to the analog ground inputs. The example includes the ADR421

2.5 V reference and the AD8628 low offset and zero-drift reference buffer.

Table 10. AD5542A Bipolar Code Table

| DAC Latch Contents | | Analog Output |
|--------------------|-----------|--|
| MSB | LSB | |
| 1111 | 1111 1111 | $+V_{REF} \times (32,767/32,768)$ |
| 1000 | 0000 0001 | $+V_{REF} \times (1/32,768)$ |
| 1000 | 0000 0000 | 0 V |
| 0111 | 1111 1111 | $-V_{REF} \times (1/32,768)$ |
| 0000 | 0000 0000 | $-V_{REF} \times (32,768/32,768) = -V_{REF}$ |

Assuming a perfect reference, the worst-case bipolar output voltage can be calculated from the following equation:

$$V_{OUT-BIP} = \frac{[(V_{OUT-UNI} + V_{OS})(2 + RD) - V_{REF}(1 + RD)]}{1 + (2 + RD)A}$$

where:

$V_{OUT-BIP}$ is the bipolar mode worst-case output

$V_{OUT-UNI}$ is the unipolar mode worst-case output.

V_{OS} is the external op amp input offset voltage.

RD is the R_{FB} and R_{INV} resistor matching error.

A is the op amp open-loop gain.

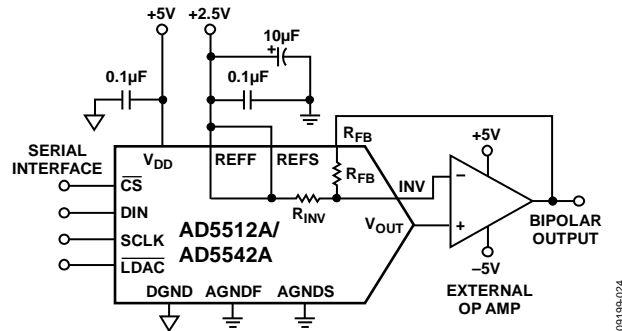

Figure 32. Bipolar Output

OUTPUT AMPLIFIER SELECTION

For bipolar mode, a precision amplifier should be used and supplied from a dual power supply. This provides the $\pm V_{REF}$ output. In a single-supply application, selection of a suitable op amp may be more difficult because the output swing of the amplifier does not usually include the negative rail, in this case, AGND. This can result in some degradation of the specified performance unless the application does not use codes near zero.

The selected op amp must have a very low-offset voltage (the DAC LSB is 38 μ V for the AD5542A with a 2.5 V reference) to eliminate the need for output offset trims. Input bias current should also be very low because the bias current, multiplied by the DAC output impedance (approximately 6 k Ω), adds to the zero-code error. Rail-to-rail input and output performance is required. For fast settling, the slew rate of the op amp should not impede the settling time of the DAC. Output impedance of the DAC is constant and code-independent, but to minimize gain errors, the input impedance of the output amplifier should be as high as possible. The amplifier should also have a 3 dB bandwidth of 1 MHz or greater. The amplifier adds another time constant to the system, thus increasing the settling time of the output. A higher 3 dB amplifier bandwidth results in a shorter effective settling time of the combined DAC and amplifier.

FORCE SENSE AMPLIFIER SELECTION

Use single-supply, low-noise amplifiers. A low-output impedance at high frequencies is preferred because the amplifiers must be able to handle dynamic currents of up to ± 20 mA.

REFERENCE AND GROUND

Because the input impedance is code-dependent, the reference pin should be driven from a low impedance source. The AD5512A/AD5542A operate with a voltage reference ranging from 2 V to V_{DD} . References below 2 V result in reduced accuracy. The full-scale output voltage of the DAC is determined by the reference. Table 9 and Table 10 outline the analog output voltage or particular digital codes. For optimum performance, Kelvin sense connections are provided on the AD5512A/AD5542A.

If the application doesn't require separate force and sense lines, tie the lines close to the package to minimize voltage drops between the package leads and the internal die.

POWER-ON RESET

The AD5512A/AD5542A have a power-on reset function to ensure that the output is at a known state on power-up. On power-up, the DAC register MSB is 1 and all other bits are 0 until the data is loaded from the serial register. However, the serial register is not cleared on power-up; therefore, its contents are undefined. When loading data initially to the DAC, 16 bits or more should be loaded to prevent erroneous data appearing on the output. If more than 16 bits are loaded, the last 16 are kept, and if less than 16 bits are loaded, bits remain from the previous word. If the AD5512A/AD5542A must be interfaced with data shorter than 16 bits, the data should be padded with 0s at the LSBs.

POWER SUPPLY AND REFERENCE BYPASSING

For accurate high-resolution performance, it is recommended that the reference and supply pins be bypassed with a 10 μ F tantalum capacitor in parallel with a 0.1 μ F ceramic capacitor.

APPLICATIONS INFORMATION

MICROPROCESSOR INTERFACING

Microprocessor interfacing to the [AD5512A/AD5542A](#) is via a serial bus that uses standard protocol that is compatible with DSP processors and microcontrollers. The communications channel requires a 3- or 4-wire interface consisting of a clock signal, a data signal, and a synchronization signal. The [AD5512A/AD5542A](#) require a 16-bit data-word with data valid on the rising edge of SCLK. The DAC update can be done automatically when all the data is clocked in, or it can be done under the control of the LDAC.

AD5512A/AD5542A TO ADSP-BF531 INTERFACE

The SPI interface of the [AD5512A/AD5542A](#) is designed to be easily connected to industry-standard DSPs and microcontrollers. Figure 33 shows how the [AD5512A/AD5542A](#) can be connected to the Analog Devices, Inc., Blackfin® DSP. The Blackfin has an integrated SPI port that can be connected directly to the SPI pins of the [AD5512A/AD5542A](#).

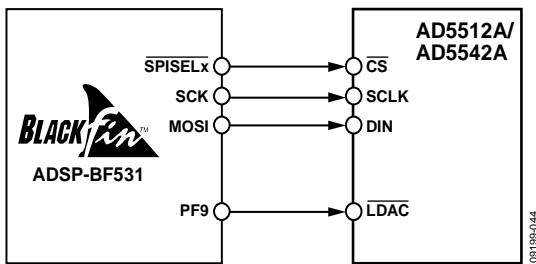

Figure 33. [AD5512A/AD5542A](#) to [ADSP-BF531](#) Interface

AD5512A/AD5542A TO SPORT INTERFACE

The Analog Devices [ADSP-BF527](#) has one SPORT serial port. Figure 34 shows how one SPORT interface can be used to control the [AD5512A/AD5542A](#).

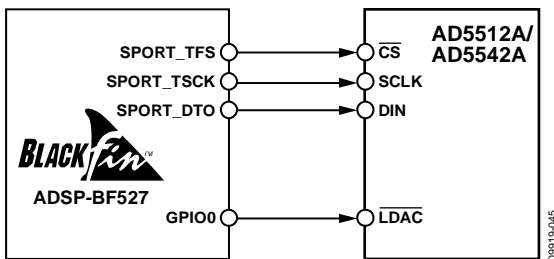
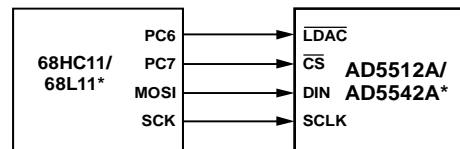

Figure 34. [AD5512A/AD5542A](#) to [ADSP-BF527](#) Interface

AD5512A/AD5542A TO 68HC11/68L11 INTERFACE

Figure 35 shows a serial interface between the [AD5512A/AD5542A](#) and the 68HC11/68L11 microcontroller. SCK of the 68HC11/68L11 drives the SCLK of the DAC, and the MOSI output drives the serial data line serial DIN. The CS signal is driven from one of the port lines. The 68HC11/68L11 is configured for master mode: MSTR = 1, CPOL = 0, and CPHA = 0. Data appearing on the MOSI output is valid on the rising edge of SCK.



*ADDITIONAL PINS OMITTED FOR CLARITY.

Figure 35. [AD5512A/AD5542A](#) to 68HC11/68L11 Interface

AD5512A/AD5542A TO MICROWIRE INTERFACE

Figure 36 shows an interface between the [AD5512A/AD5542A](#) and any MICROWIRE-compatible device. Serial data is shifted out on the falling edge of the serial clock and into the [AD5512A/AD5542A](#) on the rising edge of the serial clock. No glue logic is required because the DAC clocks data into the input shift register on the rising edge.

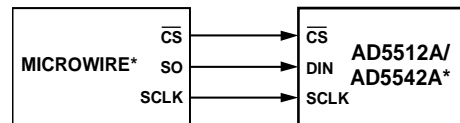

*ADDITIONAL PINS OMITTED FOR CLARITY.

Figure 36. [AD5512A/AD5542A](#) to MICROWIRE Interface

LAYOUT GUIDELINES

In any circuit where accuracy is important, careful consideration of the power supply and ground return layout helps to ensure the rated performance. Design the printed circuit board (PCB) on which the AD5512A/AD5542A is mounted so that the analog and digital sections are separated and confined to certain areas of the board. If the AD5512A/AD5542A are in a system where multiple devices require an analog ground-to-digital ground connection, make the connection at one point only. Establish the star ground point as close as possible to the device.

The AD5512A/AD5542A should have ample supply bypassing of 10 μF in parallel with 0.1 μF on each supply located as close to the package as possible, ideally right up against the device. The 10 μF capacitors are the tantalum bead type. The 0.1 μF capacitor should have low effective series resistance (ESR) and low effective series inductance (ESI), such as the common ceramic types, which provide a low impedance path to ground at high frequencies to handle transient currents due to internal logic switching.

GALVANICALLY ISOLATED INTERFACE

In many process control applications, it is necessary to provide an isolation barrier between the controller and the unit being controlled to protect and isolate the controlling circuitry from any hazardous common-mode voltages that may occur. *iCoupler*[®] products from Analog Devices provide voltage isolation in excess of 2.5 kV. The serial loading structure of the AD5512A/AD5542A makes the parts ideal for isolated interfaces because the number of interface lines is kept to a minimum. Figure 37 shows a 4-channel isolated interface to the AD5512A/AD5542A using an ADuM1400. For further information, visit <http://www.analog.com/icouplers>.

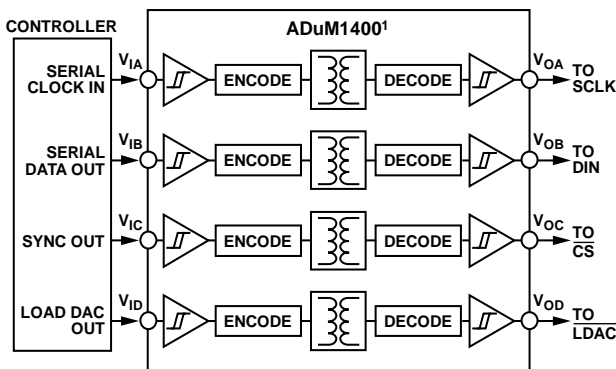

¹ADDITIONAL PINS OMITTED FOR CLARITY.

Figure 37. Isolated Interface

DECODING MULTIPLE DACS

The $\overline{\text{CS}}$ pin of the AD5512A/AD5542A can be used to select one of a number of DACs. All devices receive the same serial clock and serial data, but only one device receives the $\overline{\text{CS}}$ signal at any one time. The DAC addressed is determined by the decoder. There is some digital feedthrough from the digital input lines. Using a burst clock minimizes the effects of digital feedthrough on the analog signal channels. Figure 38 shows a typical circuit.

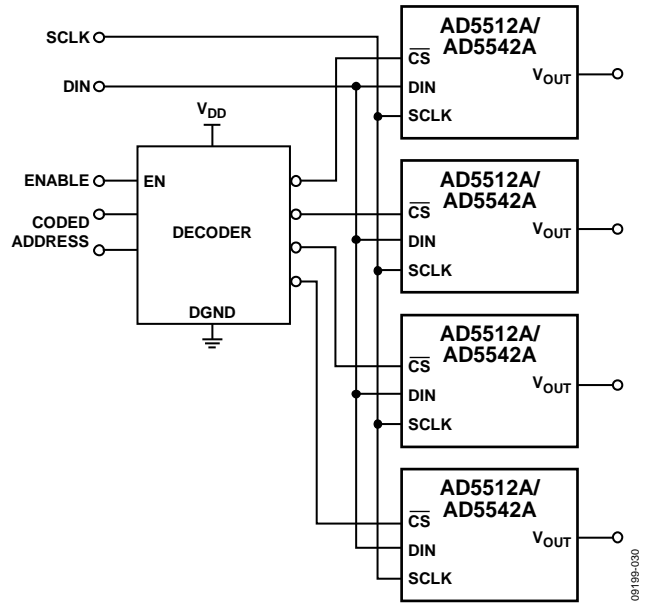
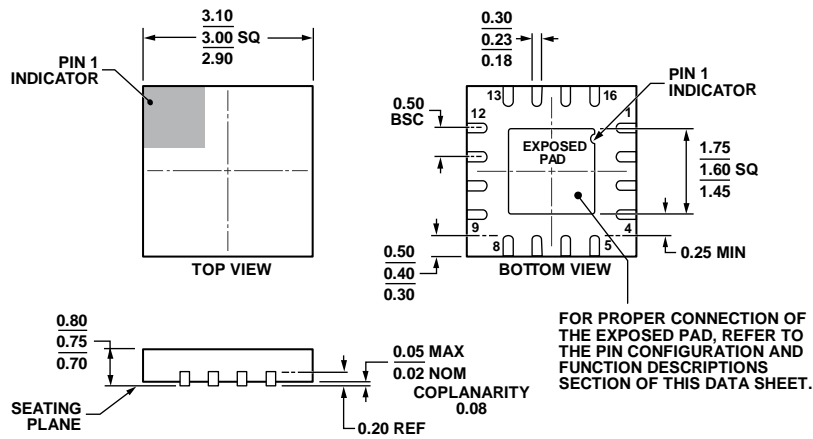

Figure 38. Addressing Multiple DACs

OUTLINE DIMENSIONS



COMPLIANT TO JEDEC STANDARDS MO-220-WEED-6.

Figure 39. 16-Lead Lead Frame Chip Scale Package [LFCSP_WQ]
 3 mm x 3 mm Body, Very Very Thin Quad
 (CP-16-22)
 Dimensions shown in millimeters

06-16-2010-E

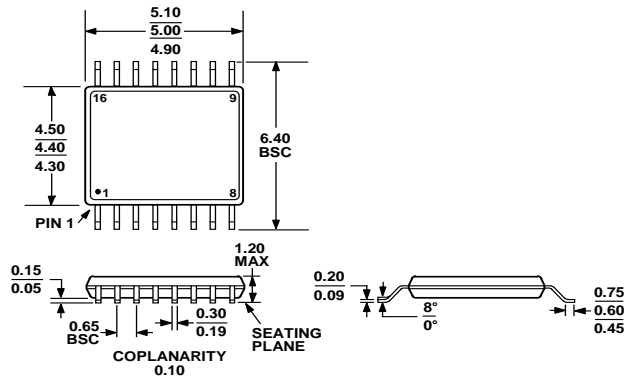

COMPLIANT TO JEDEC STANDARDS MO-153-AB

Figure 40. 16-Lead Thin Shrink Small Outline Package [TSSOP]
 (RU-16)
 Dimensions shown in millimeters

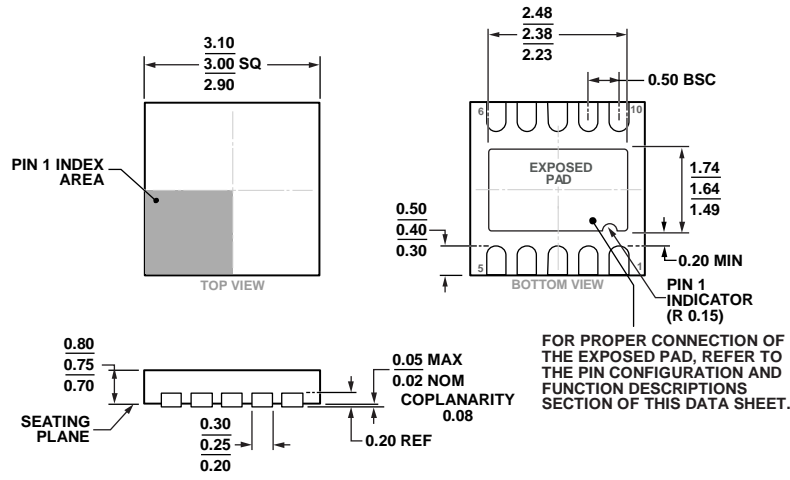

Figure 41. 10-Lead Lead Frame Chip Scale Package [LFCSP_WD]
 3 mm × 3 mm Body, Very Very Thin, Dual Lead
 (CP-10-9)
 Dimensions shown in millimeters

02-05-2015-C

ORDERING GUIDE

| Model ¹ | INL | DNL | Power On Reset to Code | Temperature Range | Package Description | Package Option | Branding |
|--------------------|--------|--------|------------------------|-------------------|--------------------------|----------------|----------|
| AD5512AACPZ-REEL7 | ±1 LSB | ±1 LSB | Midscale | -40°C to +125°C | 16-Lead LFCSP_WQ | CP-16-22 | DFQ |
| AD5512AACPZ-500RL7 | ±1 LSB | ±1 LSB | Midscale | -40°C to +125°C | 16-Lead LFCSP_WQ | CP-16-22 | DFQ |
| AD5542ABRUZ | ±1 LSB | ±1 LSB | Midscale | -40°C to +85°C | 16-Lead TSSOP | RU-16 | |
| AD5542ABRUZ-REEL7 | ±1 LSB | ±1 LSB | Midscale | -40°C to +85°C | 16-Lead TSSOP | RU-16 | |
| AD5542AARUZ | ±2 LSB | ±1 LSB | Midscale | -40°C to +85°C | 16-Lead TSSOP | RU-16 | |
| AD5542AARUZ-REEL7 | ±2 LSB | ±1 LSB | Midscale | -40°C to +85°C | 16-Lead TSSOP | RU-16 | |
| AD5542ABCPZ-REEL7 | ±1 LSB | ±1 LSB | Midscale | -40°C to +85°C | 16-Lead LFCSP_WQ | CP-16-22 | DFL |
| AD5542ACPZ-REEL7 | ±2 LSB | ±1 LSB | Midscale | -40°C to +85°C | 16-Lead LFCSP_WQ | CP-16-22 | DFK |
| AD5542ABCPZ-1-RL7 | ±1 LSB | ±1 LSB | Midscale | -40°C to +85°C | 10-Lead LFCSP_WD | CP-10-9 | DFM |
| AD5542ABCPZ-500RL7 | ±1 LSB | ±1 LSB | Midscale | -40°C to +85°C | 16-Lead LFCSP_WQ | CP-16-22 | DFL |
| EVAL-AD5542ASDZ | | | | | AD5541A Evaluation Board | | |

¹ Z = RoHS Compliant Part.

Looking for pricing, stock, or lifecycle information?

Click below to explore more details on WIN SOURCE:

⊖ [View AD5512AACPZ-REEL7 on WIN SOURCE](#)

⊖ [Analog Devices Inc. Information](#)

Optimize Your Supply Chain with WIN SOURCE Solutions

- ✓ Global Sourcing Solution
- ✓ Obsolete Management
- ✓ Cost Control Management
- ✓ Shortage Management
- ✓ Alternative Solution
- ✓ Excess Inventory Management