



**THE DATASHEET OF  
AD538SD/883B**



### FEATURES

- $V_o = V_Y(V_Z/V_X)^m$  transfer function
- Wide dynamic range (denominator) –1000:1
- Simultaneous multiplication and division
- Resistor-programmable powers and roots
- No external trims required
- Low input offsets <100  $\mu$ V
- Low error  $\pm 0.25\%$  of reading (100:1 range)
- Monolithic construction
- Real-time analog multiplication, division and exponentiation
- High accuracy analog division with a wide input dynamic range
- On board +2 V or +10 V scaling reference
- Voltage and current (summing) input modes
- Monolithic construction with lower cost and higher reliability than hybrid and modular circuits

### APPLICATIONS

- One- or two-quadrant multiply/divide
- Log ratio computation
- Squaring/square rooting
- Trigonometric function approximations
- Linearization via curve fitting
- Precision AGC
- Power functions

### GENERAL DESCRIPTION

The AD538 is a monolithic real-time computational circuit that provides precision analog multiplication, division, and exponentiation. The combination of low input and output offset voltages and excellent linearity results in accurate computation over an unusually wide input dynamic range. Laser wafer trimming makes multiplication and division with errors as low as 0.25% of reading possible, while typical output offsets of 100  $\mu$ V or less add to the overall off-the-shelf performance level. Real-time analog signal processing is further enhanced by the 400 kHz bandwidth of the device.

The overall transfer function of the AD538 is  $V_o = V_Y(V_Z/V_X)^m$ . Programming a particular function is via pin strapping. No external components are required for one-quadrant (positive input) multiplication and division. Two-quadrant (bipolar numerator) division is possible with the use of external level shifting and scaling resistors. The desired scale factor for both

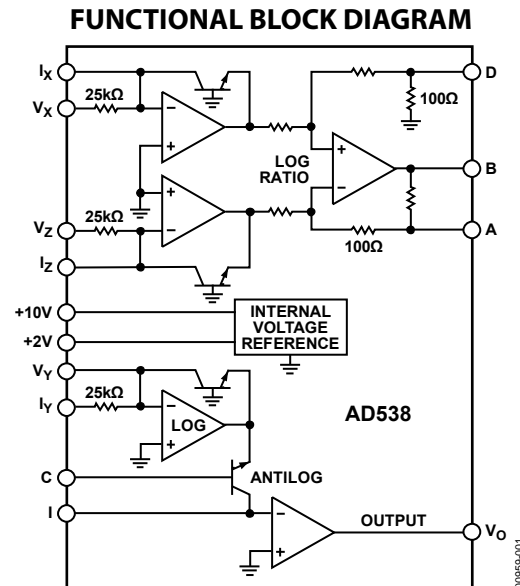

Figure 1.

multiplication and division can be set using the on-chip +2 V or +10 V references, or controlled externally to provide simultaneous multiplication and division. Exponentiation with an  $m$  value from 0.2 to 5 can be implemented with the addition of one or two external resistors.

Direct log ratio computation is possible by using only the log ratio and output sections of the chip. Access to the multiple summing junctions adds further to the flexibility of the AD538. Finally, a wide power supply range of  $\pm 4.5$  V to  $\pm 18$  V allows operation from standard  $\pm 5$  V,  $\pm 12$  V and  $\pm 15$  V supplies.

The AD538 is available in two accuracy grades (A and B) over the industrial ( $-25^\circ\text{C}$  to  $+85^\circ\text{C}$ ) temperature range and one grade (S) over the military ( $-55^\circ\text{C}$  to  $+125^\circ\text{C}$ ) temperature range. The device is packaged in an 18-lead TO-118 hermetic side-brazed ceramic DIP. A-grade chips are also available.

#### Rev. E

Information furnished by Analog Devices is believed to be accurate and reliable. However, no responsibility is assumed by Analog Devices for its use, nor for any infringements of patents or other rights of third parties that may result from its use. Specifications subject to change without notice. No license is granted by implication or otherwise under any patent or patent rights of Analog Devices. Trademarks and registered trademarks are the property of their respective owners.

**TABLE OF CONTENTS**

Features .....	1	Stability Precautions.....	10
Applications.....	1	Using The Voltage References .....	10
Functional Block Diagram .....	1	One-Quadrant Multiplication/Division.....	11
General Description .....	1	Two-Quadrant Division .....	12
Revision History .....	2	Log Ratio Operation .....	12
Specifications.....	3	Analog Computation Of Powers And Roots.....	13
Absolute Maximum Ratings.....	5	Square Root Operation.....	13
ESD Caution.....	5	Applications Information .....	15
Pin Configuration and Function Descriptions.....	6	Transducer Linearization .....	15
Typical Performance Characteristics .....	7	ARC-Tangent Approximation .....	15
Theory of Operation .....	9	Outline Dimensions .....	16
Re-Examination of Multiplier/Divider Accuracy .....	9	Ordering Guide .....	16
Functional Description.....	10		

**REVISION HISTORY****6/11—Rev. D to Rev. E**

Updated Format.....	Universal
Added Table 3.....	6
Changes to Ordering Guide .....	11

**5/10—Rev. C to Rev. D**

Updated Outline Dimensions .....	11
Changes to Ordering Guide .....	11

# SPECIFICATIONS

$V_S = \pm 15\text{ V}$ ,  $T_A = 25^\circ\text{C}$ , unless otherwise noted.

Table 1.

Parameter	Test Conditions/ Comments	AD538AD			AD538BD			AD538SD			Unit
		Min	Typ	Max	Min	Typ	Max	Min	Typ	Max	
MULTIPLIER DIVIDER PERFORMANCE											
Nominal Transfer Function	$10\text{ V} \geq V_X, V_Y, V_Z \geq 0$	$V_O = V_Y(V_Z/V_X)^m$			$V_O = V_Y(V_Z/V_X)^m$			$V_O = V_Y(V_Z/V_X)^m$			
Total Error Terms	$400\ \mu\text{A} \geq I_X, I_Y, I_Z \geq 0$	$V_O = 25\ \text{k}\Omega \times I_Y(I_Z/I_X)^m$			$V_O = 25\ \text{k}\Omega \times I_Y(I_Z/I_X)^m$			$V_O = 25\ \text{k}\Omega \times I_Y(I_Z/I_X)^m$			
100:1 Input Range <sup>1</sup>	$100\ \text{mV} \leq V_X \leq 10\ \text{V}$	$\pm 0.5$	$\pm 1$		$\pm 0.25$	$\pm 0.5$		$\pm 0.5$	$\pm 1$		% of Reading + $\mu\text{V}$
	$100\ \text{mV} \leq V_Y \leq 10\ \text{V}$	$\pm 200$	$\pm 500$		$\pm 100$	$\pm 250$		$\pm 200$	$\pm 500$		
	$100\ \text{mV} \leq V_Z \leq 10\ \text{V}$										
	$V_Z \leq 10\ \text{V}_X, m = 1.0$										
	$T_A = T_{\text{MIN}}$ to $T_{\text{MAX}}$	$\pm 1$	$\pm 2$		$\pm 0.5$	$\pm 1$		$\pm 1.25$	$\pm 2.5$		% of Reading + $\mu\text{V}$
		$\pm 450$	$\pm 750$		$\pm 350$	$\pm 500$		$\pm 750$	$\pm 1000$		
Wide Dynamic Range <sup>2</sup>	$100\ \text{mV} \leq V_X \leq 10\ \text{V}$	$\pm 1$	$\pm 2$		$\pm 0.5$	$\pm 1$		$\pm 1$	$\pm 2$		% of Reading +
	$100\ \text{mV} \leq V_Y \leq 10\ \text{V}$	$\pm 200$	$\pm 500$		$\pm 100$	$\pm 250$		$\pm 200$	$\pm 500$		$\mu\text{V}$
	$100\ \text{mV} \leq V_Z \leq 10\ \text{V}$	$\pm 100$	$\pm 250$		$\pm 750$	$\pm 150$		$\pm 200$	$\pm 250$		$\mu\text{V} \times (V_Y + V_Z)/V_X$
	$V_Z \leq 10\ \text{V}_X, m = 1.0$										
	$T_A = T_{\text{MIN}}$ to $T_{\text{MAX}}$	$\pm 1$	$\pm 3$		$\pm 1$	$\pm 2$		$\pm 2$	$\pm 4$		% of Reading +
		$\pm 450$	$\pm 750$		$\pm 350$	$\pm 500$		$\pm 750$	$\pm 1000$		$\mu\text{V} +$
		$\pm 450$	$\pm 750$		$\pm 350$	$\pm 500$		$\pm 750$	$\pm 1000$		$\mu\text{V} \times (V_Y +$ $V_Z)/V_X$
Exponent (m) Range	$T_A = T_{\text{MIN}}$ to $T_{\text{MAX}}$	0.2	5		0.2	5		0.2	5		
OUTPUT CHARACTERISTICS											
Offset Voltage	$V_Y = 0, V_C = -600\ \text{mV}$		$\pm 200$	$\pm 500$		$\pm 100$	$\pm 250$		$\pm 200$	$\pm 500$	$\mu\text{V}$
	$T_A = T_{\text{MIN}}$ to $T_{\text{MAX}}$		$\pm 450$	$\pm 750$		$\pm 350$	$\pm 500$		$\pm 750$	$\pm 1000$	$\mu\text{V}$
Output Voltage Swing	$R_L = 2\ \text{k}\Omega$	-11		+11	-11		+11	-11		+11	V
Output Current		5	10		5	10		5	10		mA
FREQUENCY RESPONSE											
Slew Rate			1.4			1.4			1.4		V/ $\mu\text{s}$
Small Signal Bandwidth	$100\ \text{mV} \leq 10\ \text{V}_Y, V_Z,$ $V_X \leq 10\ \text{V}$		400			400			400		kHz
VOLTAGE REFERENCE											
Accuracy	$V_{\text{REF}} = 10\ \text{V}$ or $2\ \text{V}$		$\pm 25$	$\pm 50$		$\pm 15$	$\pm 25$		$\pm 25$	$\pm 50$	mV
Additional Error	$T_A = T_{\text{MIN}}$ or $T_{\text{MAX}}$		$\pm 20$	$\pm 30$		$\pm 20$	$\pm 30$		$\pm 30$	$\pm 50$	mV
Output Current	$V_{\text{REF}} = 10\ \text{V}$ to $2\ \text{V}$	1	2.5		1	2.5		1	2.5		mA
Power Supply Rejection											
+2 V = $V_{\text{REF}}$	$\pm 4.5\ \text{V} \leq V_S \leq \pm 18\ \text{V}$		300	600		300	600		300	600	$\mu\text{V}/\text{V}$
+10 V = $V_{\text{REF}}$	$\pm 13\ \text{V} \leq V_S \leq \pm 18\ \text{V}$		200	500		200	500		200	500	$\mu\text{V}/\text{V}$
POWER SUPPLY											
Rated	$R_L = 2\ \text{k}\Omega$		$\pm 15$			$\pm 15$			$\pm 15$		V
Operating Range <sup>3</sup>		$\pm 4.5$		$\pm 18$	$\pm 4.5$		$\pm 18$	$\pm 4.5$		$\pm 18$	V
PSRR	$\pm 4.5\ \text{V} < V_S < \pm 18\ \text{V}$ $V_X = V_Y = V_Z = 1\ \text{V}$ $V_O = 1\ \text{V}$		0.5	0.1		0.5	0.1		0.5	0.1	%/V
Quiescent Current			4.5	7		4.5	7		4.5	7	mA

# AD538

Parameter	Test Conditions/ Comments	AD538AD			AD538BD			AD538SD			Unit
		Min	Typ	Max	Min	Typ	Max	Min	Typ	Max	
TEMPERATURE RANGE											
Rated		-25		+85	-25		+85	-55		+125	°C
Storage		-65		+150	-65		+150	-65		+150	°C

<sup>1</sup> Over the 100 mV to 10 V operating range total error is the sum of a percent of reading term and an output offset. With this input dynamic range the input offset contribution to total error is negligible compared to the percent of reading error. Thus, it is specified indirectly as a part of the percent of reading error.

<sup>2</sup> The most accurate representation of total error with low level inputs is the summation of a percent of reading term, an output offset and an input offset multiplied by the incremental gain  $(V_1 + V_2) V_X$ .

<sup>3</sup> When using supplies below  $\pm 13$  V, the 10 V reference pin must be connected to the 2 V pin in order for the AD538 to operate correctly.

## ABSOLUTE MAXIMUM RATINGS

Table 2.

Parameter	Rating
Supply Voltage	$\pm 18$ V
Internal Power Dissipation	250 mW
Output Short Circuit-to-Ground	Indefinite
Input Voltages $V_X$ , $V_Y$ , $V_Z$	$(+V_S - 1$ V), $-1$ V
Input Currents $I_X$ , $I_Y$ , $I_Z$ , $I_O$	1 mA
Operating Temperature Range	$-25^\circ\text{C}$ to $+85^\circ\text{C}$
Storage Temperature Range	$-65^\circ\text{C}$ to $+150^\circ\text{C}$
Lead Temperature, Storage	60 sec, $+300^\circ\text{C}$
Thermal Resistance	
$\theta_{JC}$	$35^\circ\text{C}/\text{W}$
$\theta_{JA}$	$120^\circ\text{C}/\text{W}$

Stresses above those listed under Absolute Maximum Ratings may cause permanent damage to the device. This is a stress rating only; functional operation of the device at these or any other conditions above those indicated in the operational section of this specification is not implied. Exposure to absolute maximum rating conditions for extended periods may affect device reliability.

### ESD CAUTION



**ESD (electrostatic discharge) sensitive device.** Charged devices and circuit boards can discharge without detection. Although this product features patented or proprietary protection circuitry, damage may occur on devices subjected to high energy ESD. Therefore, proper ESD precautions should be taken to avoid performance degradation or loss of functionality.

## PIN CONFIGURATION AND FUNCTION DESCRIPTIONS

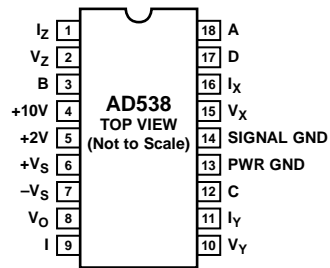

Figure 2. Pin Configuration

00959-002

Table 3.

Pin No.	Mnemonic	Description
1	$I_Z$	Current Input for the Z Multiplicand.
2	$V_Z$	Voltage Input for the Z Multiplicand.
3	B	Output of the Log Ratio Differential Amplifier. This amplifier subtracts the log of the Z input from the log of the X input, or performs the equivalent logarithmic equivalent of long division.
4	+10V	+10 V Reference Voltage Output.
5	+2V	+2 V Reference Voltage Output.
6	+ $V_S$	Positive Supply Rail.
7	- $V_S$	Negative Rail.
8	$V_O$	Output Voltage.
9	I	Current Input to the Output Amplifier.
10	$V_Y$	Voltage Input to the Y Multiplicand.
11	$I_Y$	Current Input to the Y Multiplicand.
12	C	Current Input to the Base of the Antilog Log-to-Linear Converter.
13	PWR GND	High level Power Return of the Chip.
14	SIGNAL GND	Low Level Ground Return of the Device.
15	$V_X$	Voltage Input of the X Multiplicand.
16	$I_X$	Current Input of the X Input Multiplicand.
17	D	Use for Log Ratio Function.
18	A	Use for Log Ratio Function.

# TYPICAL PERFORMANCE CHARACTERISTICS

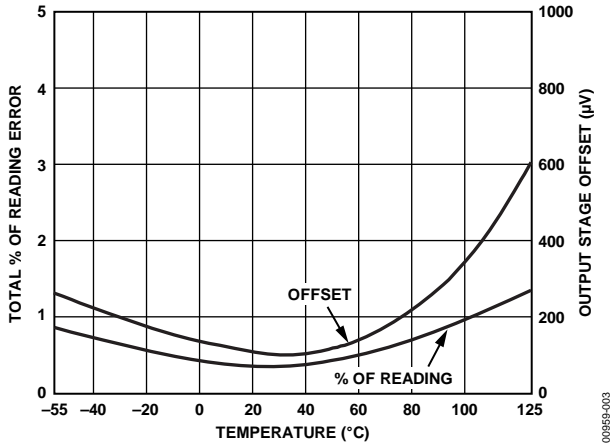

Figure 3. Multiplier Error vs. Temperature ( $100\text{ mV} < V_X, V_Y, V_Z \leq 10\text{ V}$ )

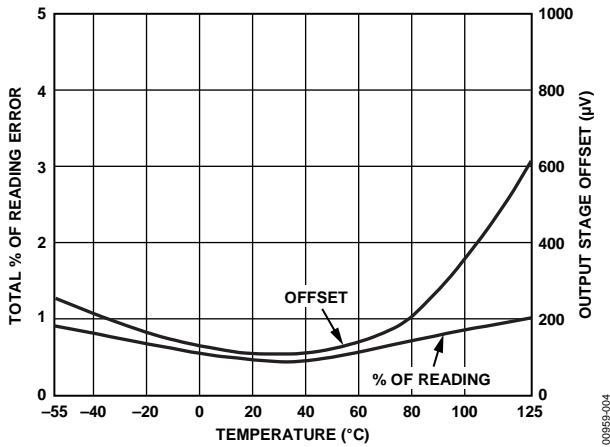

Figure 4. Divider Error vs. Temperature ( $100\text{ mV} < V_X, V_Y, V_Z \leq 10\text{ V}$ )

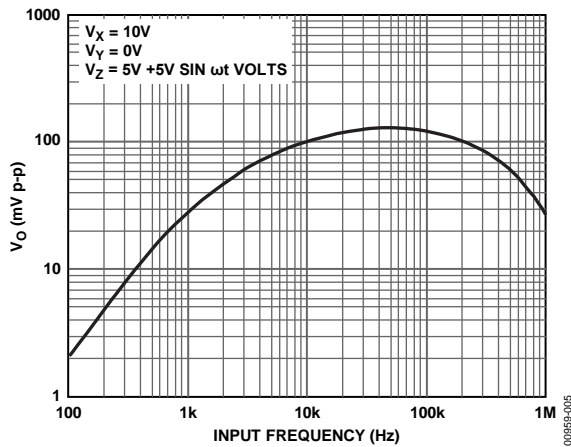

Figure 5.  $V_Z$  Feedthrough vs. Frequency

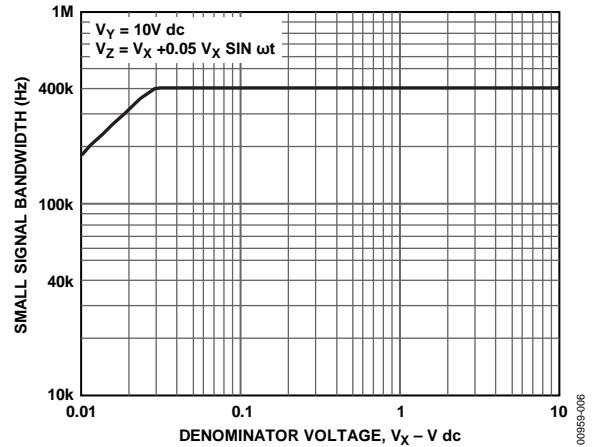

Figure 6. Small Signal Bandwidth vs. Denominator Voltage (One-Quadrant Mult/Div)

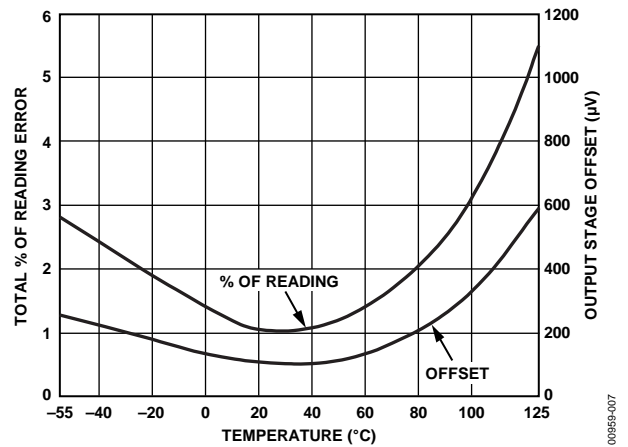

Figure 7. Multiplier Error vs. Temperature ( $10\text{ mV} < V_X, V_Y, V_Z \leq 100\text{ mV}$ )

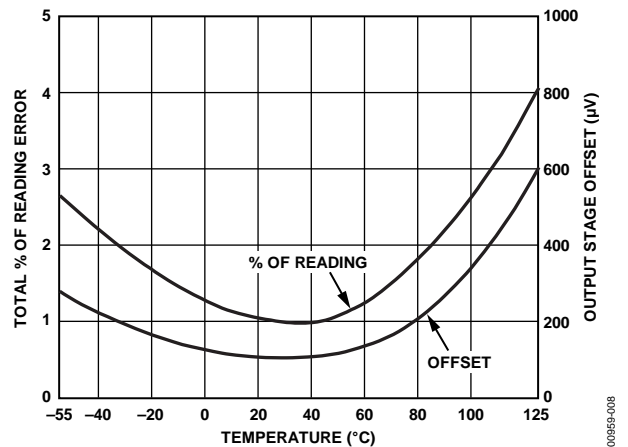

Figure 8. Divider Error vs. Temperature ( $10\text{ mV} < V_X, V_Y, V_Z \leq 100\text{ mV}$ )

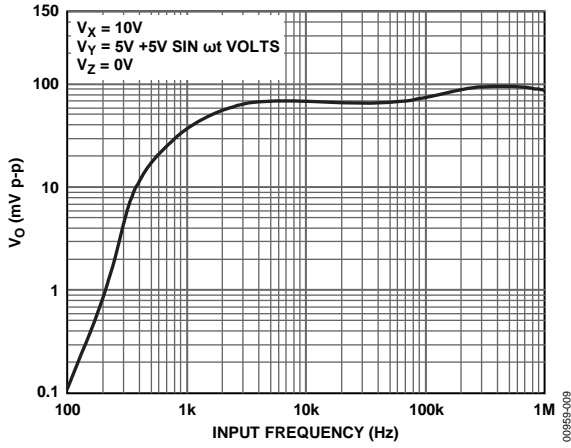

Figure 9.  $V_\gamma$  Feedthrough vs. Frequency

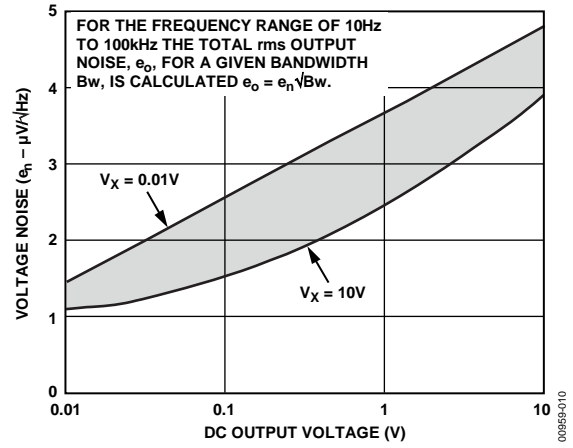

Figure 10. 1 kHz Output Noise Spectral Density vs. DC Output Voltage

# THEORY OF OPERATION

## RE-EXAMINATION OF MULTIPLIER/DIVIDER ACCURACY

Traditionally, the accuracy (actually the errors) of analog multipliers and dividers has been specified in terms of percent of full scale. Thus specified, a 1% multiplier error with a 10 V full-scale output would mean a worst-case error of +100 mV at any level within its designated output range. While this type of error specification is easy to test evaluate, and interpret, it can leave the user guessing as to how useful the multiplier actually is at low output levels, those approaching the specified error limit (in this case) 100 mV.

The error sources of the AD538 do not follow the percent of full-scale approach to specification, thus it more optimally fits the needs of the very wide dynamic range applications for which it is best suited. Rather than as a percent of full scale, the AD538's error as a multiplier or divider for a 100:1 (100 mV to 10 V) input range is specified as the sum of two error components: a percent of reading (ideal output) term plus a fixed output offset. Following this format, the AD538AD, operating as a multiplier or divider with inputs down to 100 mV, has a maximum error of ±1% of reading ±500 μV. Some sample

total error calculations for both grades over the 100:1 input range are illustrated in Table 4. This error specification format is a familiar one to designers and users of digital voltmeters where error is specified as a percent of reading ± a certain number of digits on the meter readout.

For operation as a multiplier or divider over a wider dynamic range (>100:1), the AD538 has a more detailed error specification that is the sum of three components: a percent of reading term, an output offset term, and an input offset term for the  $V_Y/V_X$  log ratio section. A sample application of this specification, taken from Table 4, for the AD538AD with  $V_Y = 1$  V,  $V_Z = 100$  mV and  $V_X = 10$  mV would yield a maximum error of ±2.0% of reading ±500 μV ± (1 V + 100 mV)/10 mV × 250 μV or ±2.0% of reading ±500 μV ± 27.5 mV. This example illustrates that with very low level inputs the AD538's incremental gain ( $V_Y + V_Z$ )/ $V_X$  has increased to make the input offset contribution to error substantial.

Table 4. Sample Error Calculation Chart (Worst Case)

	V <sub>Y</sub> Input (V)	V <sub>Z</sub> Input (V)	V <sub>X</sub> Input (V)	Ideal Output (V)	Total Offset Error Term (mV)		% of Reading Error Term (mV)		Total Error Summation (mV)		Total Error Summation as a % of the Ideal Output	
100:1 INPUT RANGE Total Error = ±% rdg ±Output V <sub>OS</sub>	10	10	10	10	0.5	(AD)	100	(AD)	100.5	(AD)	1.0	(AD)
					0.25	(BD)	50	(BD)	50.25	(BD)	0.5	(BD)
	10	0.1	0.1	10	0.5	(AD)	100	(AD)	100.5	(AD)	1.0	(AD)
					0.25	(BD)	50	(BD)	50.25	(BD)	0.5	(BD)
	1	1	1	1	0.5	(AD)	10	(AD)	10.5	(AD)	1.05	(AD)
					0.25	(BD)	5	(BD)	5.25	(BD)	0.5	(BD)
	0.1	0.1	0.1	0.1	0.5	(AD)	1	(AD)	1.5	(AD)	1.5	(AD)
					0.25	(BD)	0.5	(BD)	0.75	(BD)	0.75	(BD)
WIDE DYNAMIC RANGE Total Error = ±% rdg ± Output V <sub>OS</sub> ± Input V <sub>OS</sub> × (V <sub>Y</sub> + V <sub>Z</sub> )/V <sub>X</sub>	1	0.10	0.01	10	28	(AD)	200	(AD)	228	(AD)	2.28	(AD)
					16.75	(BD)	100	(BD)	116.75	(BD)	1.17	(BD)
	10	0.05	2	0.25	1.76	(AD)	5	(AD)	6.76	(AD)	2.7	(AD)
					1	(BD)	2.5	(BD)	3.5	(BD)	1.4	(BD)
	5	0.01	0.01	5	125.75	(AD)	100	(AD)	225.75	(AD)	4.52	(AD)
					75.4	(BD)	50	(BD)	125.4	(BD)	2.51	(BD)
	10	0.01	0.1	1	25.53	(AD)	20	(AD)	45.53	(AD)	4.55	(AD)
					15.27	(BD)	10	(BD)	25.27	(BD)	2.53	(BD)

# AD538

## FUNCTIONAL DESCRIPTION

As shown in Figure 1 and Figure 11, the  $V_Z$  and  $V_X$  inputs connect directly to the input log ratio amplifiers of the AD538. This subsection provides an output voltage proportional to the natural log of input voltage,  $V_Z$ , minus the natural log of input voltage,  $V_X$ . The output of the log ratio subsection at B can be expressed by the transfer function

$$V_B = \frac{kT}{q} \ln\left(\frac{V_Z}{V_X}\right)$$

where:

$k$  is  $1.3806 \times 10^{-23}$  J/K.

$q$  is  $1.60219 \times 10^{-19}$  C.

$T$  is in Kelvins.

The log ratio configuration may be used alone, if correctly temperature compensated and scaled to the desired output level (see the Applications Information section).

Under normal operation, the log-ratio output will be directly connected to a second functional block at Input C, the antilog subsection. This section performs the antilog according to the transfer function:

$$V_O = V_Y e^{\left(V_C \frac{q}{kT}\right)}$$

As with the log-ratio circuit included in the AD538, the user may use the antilog subsection by itself. When both subsections are combined, the output at B is tied to C, the transfer function of the AD538 computational unit is:

$$V_O = V_Y e^{\left[\left(\frac{kT}{Q}\right)\left(\frac{q}{kT}\right)\ln\left(\frac{V_Z}{V_X}\right)\right]}; V_B = V_C$$

which reduces to:

$$V_O = V_Y \left(\frac{V_Z}{V_X}\right)^m$$

Finally, by increasing the gain, or attenuating the output of the log ratio subsection via resistor programming, it is possible to raise the quantity  $V_Z/V_X$  to the  $m^{\text{th}}$  power. Without external programming,  $m$  is unity. Thus, the overall AD538 transfer function equals:

$$V_O = V_Y \left(\frac{V_Z}{V_X}\right)^m$$

where  $0.2 < m < 5$ .

When the AD538 is used as an analog divider, the  $V_Y$  input can be used to multiply the ratio  $V_Z/V_X$  by a convenient scale factor. The actual multiplication by the  $V_Y$  input signal is accomplished by adding the log of the  $V_Y$  input signal to the signal at C, which is already in the log domain.

## STABILITY PRECAUTIONS

At higher frequencies, the multistaged signal path of the AD538 can result in large phase shifts (as illustrated in Figure 11). If a condition of high incremental gain exists along that path (for example,  $V_O = V_Y \times V_Z/V_X = 10 \text{ V} \times 10 \text{ mV}/10 \text{ mV} = 10 \text{ V}$  so that  $\Delta V_O/\Delta V_X = 1000$ ), then small amounts of capacitive feedback from  $V_O$  to the current inputs  $I_Z$  or  $I_X$  can result in instability. Appropriate care should be exercised in board layout to prevent capacitive feedback mechanisms under these conditions.

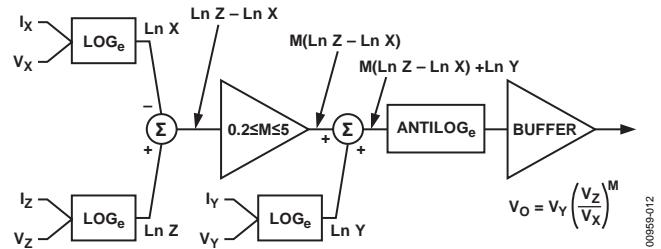

Figure 11. Model Circuit

## USING THE VOLTAGE REFERENCES

A stable band gap voltage reference for scaling is included in the AD538. It is laser-trimmed to provide a selectable voltage output of +10 V buffered (Pin 4), +2 V unbuffered (Pin 5) or any voltages between +2 V and +10.2 V buffered as shown in Figure 12. The output impedance at Pin 5 is approximately 5 kΩ. Note that any loading of this pin produces an error in the +10 V reference voltage. External loads on the +2 V output should be greater than 500 kΩ to maintain errors less than 1%.

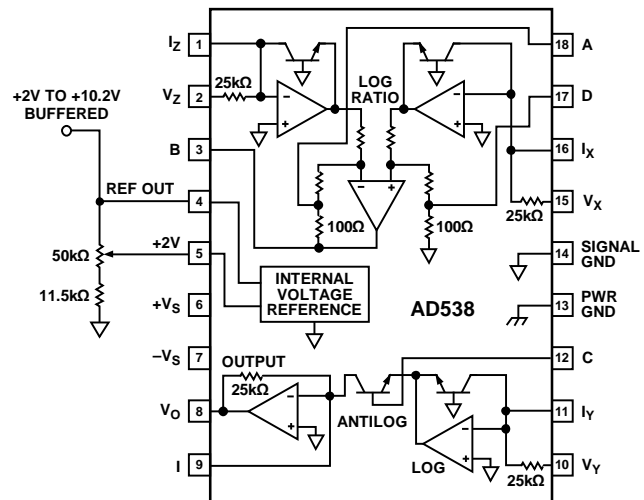

Figure 12. +2 V to +10.2 V Adjustable Reference

In situations not requiring both reference levels, the +2 V output can be converted to a buffered output by tying Pin 4 and Pin 5 together. If both references are required simultaneously, the +10 V output should be used directly and the +2 V output should be externally buffered.

**ONE-QUADRANT MULTIPLICATION/DIVISION**

Figure 13 shows how the AD538 may be easily configured as a precision one-quadrant multiplier/divider. The transfer function  $V_O = V_Y (V_Z/V_X)$  allows three independent input variables, a calculation not available with a conventional multiplier. In addition, the 1000:1 (that is, 10 mV to 10 V) input dynamic range of the AD538 greatly exceeds that of analog multipliers computing one-quadrant multiplication and division.

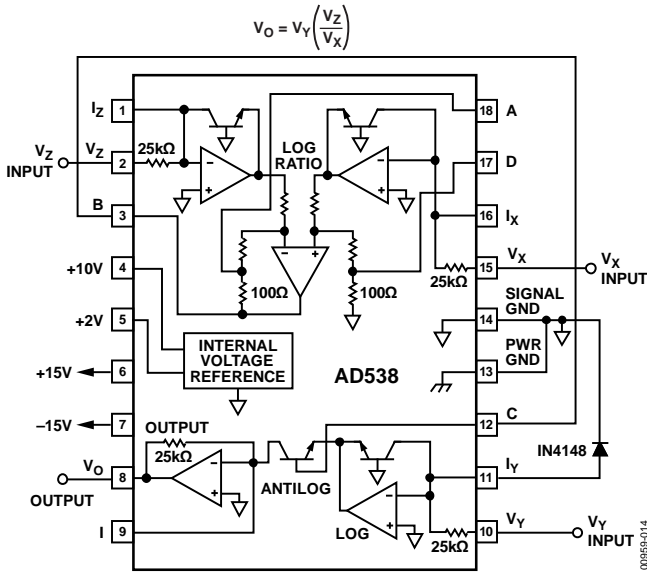

Figure 13. One-Quadrant Combination Multiplier/Divider

By simply connecting the input,  $V_X$  (Pin 15) to the 10 V reference (Pin 4), and tying the log-ratio output at B to the antilog input at C, the AD538 can be configured as a one-quadrant analog multiplier with 10 V scaling. If 2 V scaling is desired,  $V_X$  can be tied to the 2 V reference.

When the input  $V_X$  is tied to the +10 V reference terminal, the multiplier transfer function becomes:

$$V_O = V_Y \left( \frac{V_Z}{10 V} \right)$$

As a multiplier, this circuit provides a typical bandwidth of 400 kHz with values of  $V_X$ ,  $V_Y$ , or  $V_Z$  varying over a 100:1 range (that is, 100 mV to 10 V). The maximum error with a 100 mV to 10 V range for the two input variables will typically be +0.5% of reading. Using the optional Z offset trim scheme, as shown in Figure 14, this error can be reduced to +0.25% of reading.

By using the 10 V reference as the  $V_Y$  input, the circuit of Figure 13 is configured as a one-quadrant divider with a fixed scale factor. As with the one-quadrant multiplier, the inputs accept only single (positive) polarity signals. The output of the one-quadrant divider with a +10 V scale factor is:

$$V_O = 10 V \left( \frac{V_Z}{V_X} \right)$$

The typical bandwidth of this circuit is 370 kHz with 1 V to 10 V denominator input levels. At lower amplitudes, the bandwidth gradually decreases to approximately 200 kHz at the 2 mV input level.

## TWO-QUADRANT DIVISION

The two-quadrant linear divider circuit illustrated in Figure 14 uses the same basic connections as the one-quadrant version. However, in this circuit the numerator has been offset in the positive direction by adding the denominator input voltage to it. The offsetting scheme changes the divider's transfer function from

$$V_O = 10 \text{ V} \left( \frac{V_Z}{V_X} \right)$$

to

$$V_O = 10 \text{ V} \frac{(V_Z + AV_X)}{V_X} = 10 \text{ V} \left( 1A + \frac{V_Z}{V_X} \right)$$

$$= 10 \text{ A} + 10 \text{ V} \left( \frac{V_Z}{V_X} \right)$$

where:

$$A = \left( \frac{35 \text{ k}\Omega}{25 \text{ k}\Omega} \right)$$

As long as the magnitude of the denominator input is equal to or greater than the magnitude of the numerator input, the circuit accepts bipolar numerator voltages. However, under the conditions of a 0 V numerator input, the output would incorrectly equal +14 V. The offset can be removed by connecting the 10 V reference through Resistors R1 and R2 to the output section's summing Node I at Pin 9 thus providing a gain of 1.4 at the center of the trimming potentiometer. The potentiometer, R2, adjusts out or corrects this offset, leaving the desired transfer function of  $10 \text{ V} (V_Z/V_X)$ .

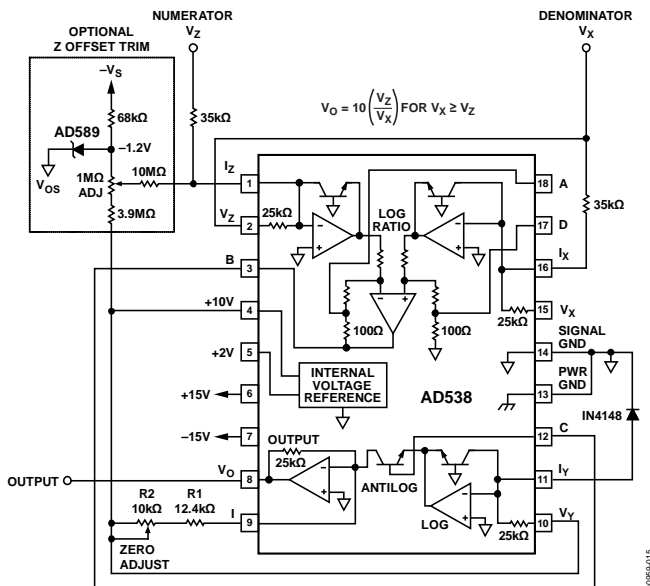

Figure 14. Two-Quadrant Division with 10V Scaling

## LOG RATIO OPERATION

Figure 15 shows the AD538 configured for computing the log of the ratio of two input voltages (or currents). The output signal from B is connected to the summing junction of the output amplifier via two series resistors. The 90.9 Ω metal film resistor effectively degrades the temperature coefficient of the  $\pm 3500 \text{ ppm}/^\circ\text{C}$  resistor to produce a  $1.09 \text{ k}\Omega + 3300 \text{ ppm}/^\circ\text{C}$  equivalent value. In this configuration, the  $V_Y$  input must be tied to some voltage less than zero ( $-1.2 \text{ V}$  in this case) removing this input from the transfer function.

The 5 kΩ potentiometer controls the circuit's scale factor adjustment providing a +1 V per decade adjustment. The output offset potentiometer should be set to provide a zero output with  $V_X = V_Z = 1 \text{ V}$ . The input  $V_Z$  adjustment should be set for an output of 3 V with  $V_Z = 1 \text{ mV}$  and  $V_X = 1 \text{ V}$ .

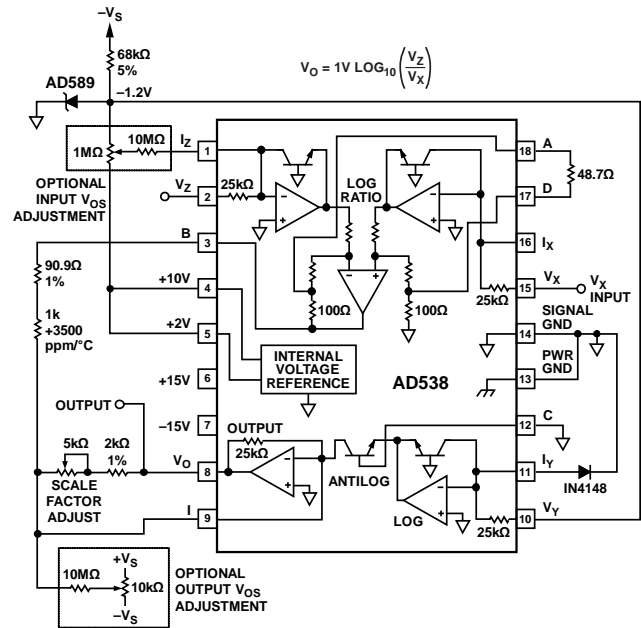

Figure 15. Log Ratio Circuit

The log ratio circuit shown achieves  $\pm 0.5\%$  accuracy in the log domain for input voltages within three decades of input range: 10 mV to 10 V. This error is not defined as a percent of full-scale output, but as a percent of input. For example, using a 1 V/decade scale factor, a 1% error in the positive direction at the input of the log ratio amplifier translates into a 4.3 mV deviation from the ideal OUTPUT (that is,  $1 \text{ V} \times \log_{10}(1.01) = 4.3214 \text{ mV}$ ). An input error 1% in the negative direction is slightly different, giving an output deviation of 4.3648 mV.

**ANALOG COMPUTATION OF POWERS AND ROOTS**

It is often necessary to raise the quotient of two input signals to a power or take a root. This could be squaring, cubing, square rooting or exponentiation to some noninteger power. Examples include power series generation. With the AD538, only one or two external resistors are required to set any desired power, over the range of 0.2 to 5. Raising the basic quantity  $V_Z/V_X$  to a power greater than one requires that the gain of the AD538's log ratio subtractor be increased, via an external resistor between the A and D pins. Similarly, a voltage divider that attenuates the log ratio output between Point B and Point C will program the power to a value less than one.

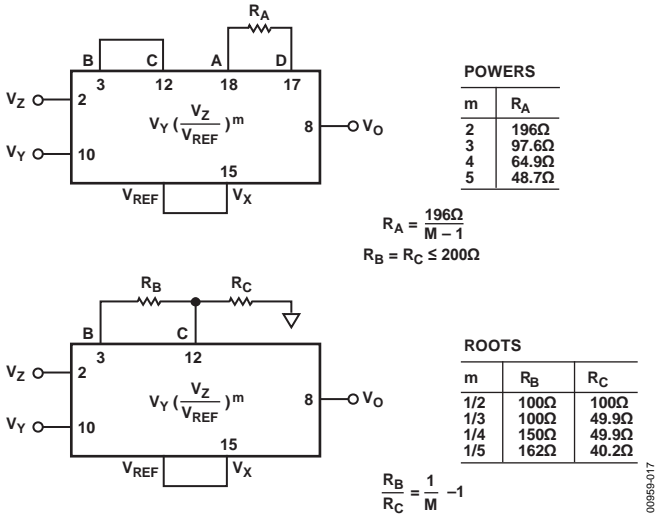

Figure 16. Basic Configurations and Transfer Functions for the AD538

**SQUARE ROOT OPERATION**

The explicit square root circuit of Figure 17 illustrates a precise method for performing a real-time square root computation. For added flexibility and accuracy, this circuit has a scale factor adjustment.

The actual square rooting operation is performed in this circuit by raising the quantity  $V_Z/V_X$  to the one-half power via the resistor divider network consisting of resistors  $R_B$  and  $R_C$ . For maximum linearity, the two resistors should be 1% (or better) ratio-matched metal film types.

1 V scaling is achieved by dividing-down the 2 V reference and applying approximately 1 V to both the  $V_Y$  and  $V_X$  inputs. In this circuit, the  $V_X$  input is intentionally set low, to about 0.95 V, so that the  $V_Y$  input can be adjusted high, permitting a  $\pm 5\%$  scale factor trim. Using this trim scheme, the output voltage will be within  $\pm 3$  mV  $\pm 0.2\%$  of the ideal value over a 10 V to 1 mV input range (80 dB). For a decreased input dynamic range of 10 mV to 10 V (60 dB) the error is even less; here the output will be within  $\pm 2$  mV  $\pm 0.2\%$  of the ideal value. The bandwidth of the AD538 square root circuit is approximately 280 kHz with a 1 V p-p sine wave with a +2 V dc offset.

This basic circuit may also be used to compute the cube, fourth or fifth roots of an input waveform. All that is required for a given root is that the correct ratio of resistors,  $R_C$  and  $R_B$ , be selected such that their sum is between 150 Ω and 200 Ω.

The optional absolute value circuit shown preceding the AD538 allows the use of bipolar input voltages. Only one op amp is required for the absolute value function because the  $I_Z$  input of the AD538 functions as a summing junction. If it is necessary to preserve the sign of the input voltage, the polarity of the op amp output may be sensed and used after the computation to switch the sign bit of a DVM chip.

# AD538

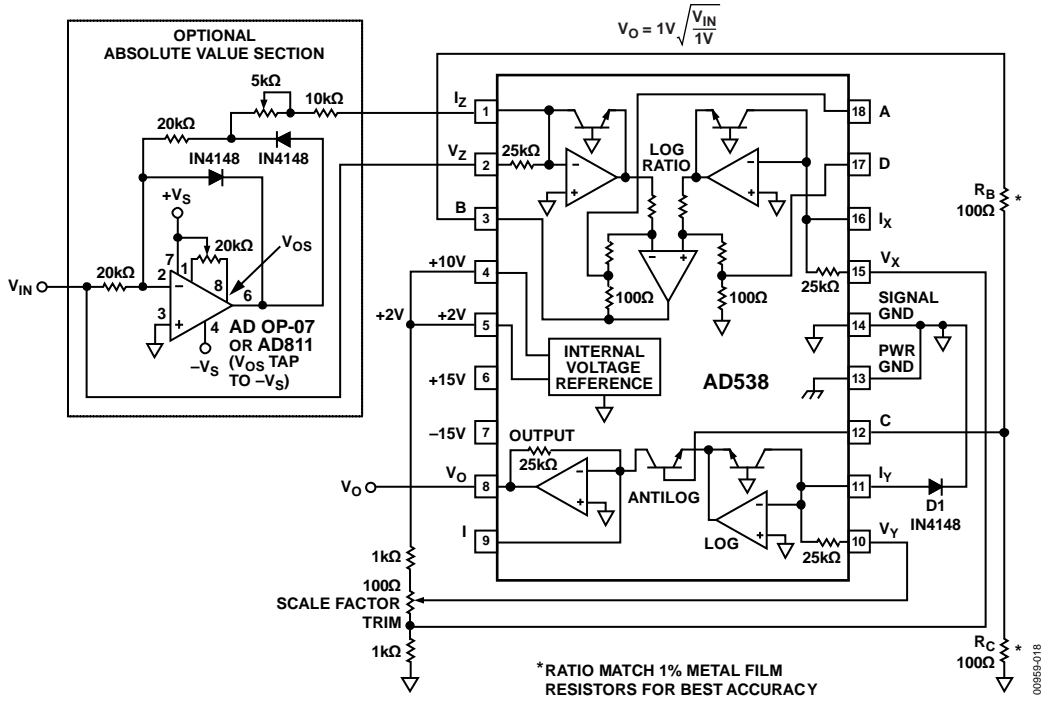

Figure 17. Square Root Circuit

## APPLICATIONS INFORMATION

### TRANSDUCER LINEARIZATION

Many electronic transducers used in scientific, commercial or industrial equipment monitor the physical properties of a device and/or its environment. Sensing (and perhaps compensating for) changes in pressure, temperature, moisture or other physical phenomenon can be an expensive undertaking, particularly where high accuracy and very low nonlinearity are important. In conventional analog systems accuracy may be easily increased by offset and scale factor trims; however, nonlinearity is usually the absolute limitation of the sensing device.

With the ability to easily program a complex analog function, the AD538 can effectively compensate for the nonlinearities of an inexpensive transducer. The AD538 can be connected between the transducer preamplifier output and the next stage of monitoring or transmitting circuitry. The recommended procedure for linearizing a particular transducer is first to find the closest function which best approximates the nonlinearity of the device and then, to select the appropriate exponent resistor value(s).

### ARC-TANGENT APPROXIMATION

The circuit of Figure 18 is typical of those AD538 applications where the quantity  $V_Z/V_X$  is raised to powers greater than one. In an approximate arc-tangent function, the AD538 will accurately compute the angle that is defined by X and Y displacements represented by input voltages  $V_X$  and  $V_Z$ . With accuracy to within one degree (for input voltages between 100  $\mu$ V and 10 V), the AD538 arc-tangent circuit is more precise than conventional analog circuits and is faster than most digital techniques. The circuit shown is set up for the transfer function:

$$V_\theta = (V_{\theta REF} - V_\theta) \left[ \frac{(V_Z)}{(V_X)} \right]^{1.21}$$

where:

$$\theta = \text{Tan}^{-1} \left( \frac{Z}{X} \right)$$

The  $(V_{\theta REF} - V_\theta)$  function is implemented in this circuit by adding together the output,  $V_\theta$ , and an externally applied reference voltage,  $V_{\theta REF}$ , via an external AD547 op amp. The 1  $\mu$ F capacitor connected around the AD547's 100 k $\Omega$  feedback resistor frequency compensates the loop (formed by the amplifier between  $V_\theta$  and  $V_Y$ ).

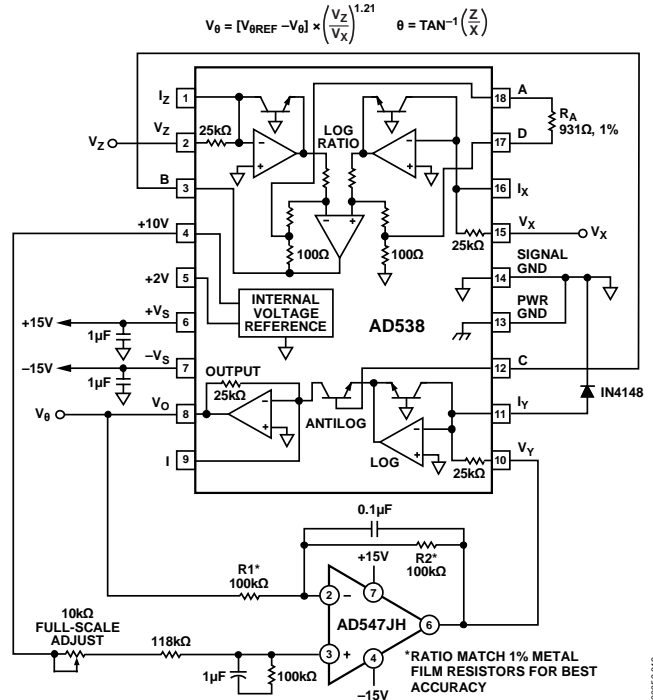
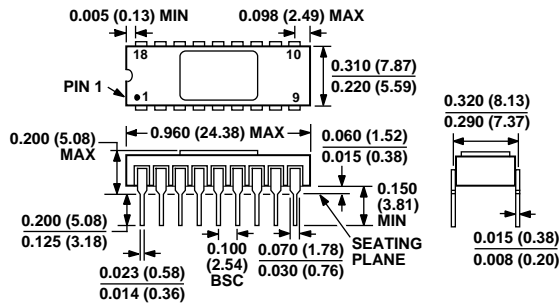

Figure 18. The Arc-Tangent Function

The  $V_B/V_A$  quantity is calculated in the same manner as in the one-quadrant divider circuit, except that the resulting quotient is raised to the 1.21 power. Resistor  $R_A$  (nominally 931  $\Omega$ ) sets the power or m factor.

For the highest arc-tangent accuracy the R1 and R2 external resistors should be ratio matched; however, the offset trim scheme shown in other circuits is not required since nonlinearity effects are the predominant source of error. Also note that instability will occur as the output approaches 90° because, by definition, the arc-tangent function is infinite and therefore, the gain of the AD538 will be extremely high.

## OUTLINE DIMENSIONS



CONTROLLING DIMENSIONS ARE IN INCHES; MILLIMETER DIMENSIONS (IN PARENTHESES) ARE ROUNDED-OFF INCH EQUIVALENTS FOR REFERENCE ONLY AND ARE NOT APPROPRIATE FOR USE IN DESIGN.

Figure 19. 18-Lead Side-Brazed Ceramic Dual In-Line Package [SBDIP] (D-18)

Dimensions shown in inches and (millimeters)

## ORDERING GUIDE

Model <sup>1</sup>	Temperature Range	Package Description	Package Option
AD538ACHIPS	-25°C to +85°C	Chips	
AD538AD	-25°C to +85°C	18-Lead Side-Brazed Ceramic Dual In-Line Package [SBDIP]	D-18
AD538ADZ	-25°C to +85°C	18-Lead Side-Brazed Ceramic Dual In-Line Package [SBDIP]	D-18
AD538BD	-25°C to +85°C	18-Lead Side-Brazed Ceramic Dual In-Line Package [SBDIP]	D-18
AD538BDZ	-25°C to +85°C	18-Lead Side-Brazed Ceramic Dual In-Line Package [SBDIP]	D-18
AD538SD	-55°C to +125°C	18-Lead Side-Brazed Ceramic Dual In-Line Package [SBDIP]	D-18
AD538SD/883B	-55°C to +125°C	18-Lead Side-Brazed Ceramic Dual In-Line Package [SBDIP]	D-18

<sup>1</sup> Z = RoHS Compliant Part.

## Looking for pricing, stock, or lifecycle information?

Click below to explore more details on WIN SOURCE:

 [View AD538SD/883B on WIN SOURCE](#)

 [Analog Devices Inc. Information](#)

## Optimize Your Supply Chain with WIN SOURCE Solutions

-  Global Sourcing Solution
-  Obsolete Management
-  Cost Control Management
-  Shortage Management
-  Alternative Solution
-  Excess Inventory Management