



**THE DATASHEET OF
SN74ACT7807-25FN**



- Free-Running Read and Write Clocks Can Be Asynchronous or Coincident
- Read and Write Operations Synchronized to Independent System Clocks
- Input-Ready Flag Synchronized to Write Clock
- Output-Ready Flag Synchronized to Read Clock
- 2048 Words by 9 Bits
- Low-Power Advanced CMOS Technology
- Programmable Almost-Full/Almost-Empty Flag
- Input-Ready, Output-Ready, and Half-Full Flags
- Cascadable in Word Width and/or Word Depth
- Fast Access Times of 12 ns With a 50-pF Load
- Data Rates up to 67 MHz
- 3-State Outputs
- Package Options Include 44-Pin Plastic Leaded Chip Carrier (FN) and 64-Pin Thin Quad Flat (PAG, PM) Packages

description

The SN74ACT7807 is a 2048-word by 9-bit FIFO with high speed and fast access times. It processes data at rates up to 67 MHz and access times of 12 ns in a bit-parallel format. Data outputs are noninverting with respect to the data inputs. Expansion is easily accomplished in both word width and word depth.

The write-clock (WRTCLK) and read-clock (RDCLK) inputs should be free running and can be asynchronous or coincident. Data is written to memory on the rising edge of WRTCLK when the write-enable (WRTEN1/DP9, WRTEN2) inputs are high and the input-ready (IR) flag output is high. Data is read from memory on the rising edge of RDCLK when the read-enable (RDEN1, RDEN2) and output-enable (OE) inputs are high and the output-ready (OR) flag output is high. The first word written to memory is clocked through to the output buffer regardless of the levels on RDEN1, RDEN2, and OE. The OR flag indicates that valid data is present on the output buffer.

The FIFO can be reset asynchronous to WRTCLK and RDCLK. $\overline{\text{RESET}}$ must be asserted while at least four WRTCLK and four RDCLK cycles occur to clear the synchronizing registers. Resetting the FIFO initializes the IR, OR, and half-full (HF) flags low and the almost-full/almost-empty (AF/AE) flag high. The FIFO must be reset upon power up.

The SN74ACT7807 is characterized for operation from 0°C to 70°C.



Please be aware that an important notice concerning availability, standard warranty, and use in critical applications of Texas Instruments semiconductor products and disclaimers thereto appears at the end of this data sheet.

PRODUCTION DATA information is current as of publication date. Products conform to specifications per the terms of Texas Instruments standard warranty. Production processing does not necessarily include testing of all parameters.

 **TEXAS
INSTRUMENTS**

POST OFFICE BOX 655303 • DALLAS, TEXAS 75265

Copyright © 1998, Texas Instruments Incorporated

CLOCKED FIRST-IN, FIRST-OUT MEMORY

SCAS200D – JANUARY 1991 – REVISED APRIL 1998

FN PACKAGE
(TOP VIEW)

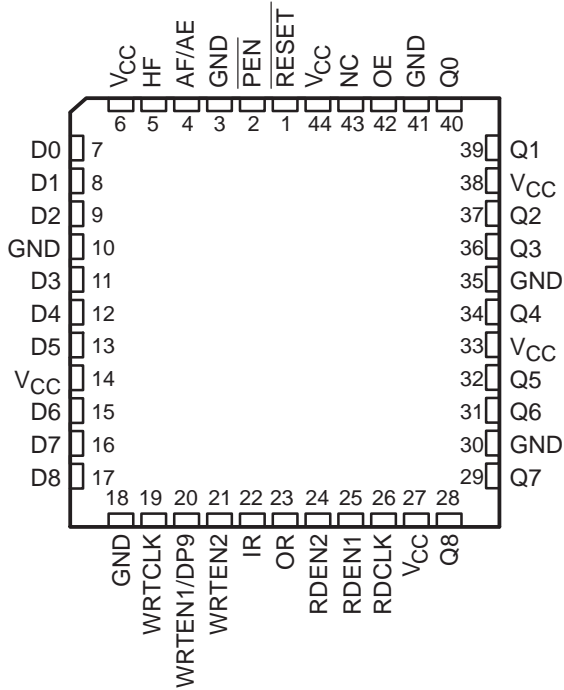

PAG OR PM PACKAGE
(TOP VIEW)

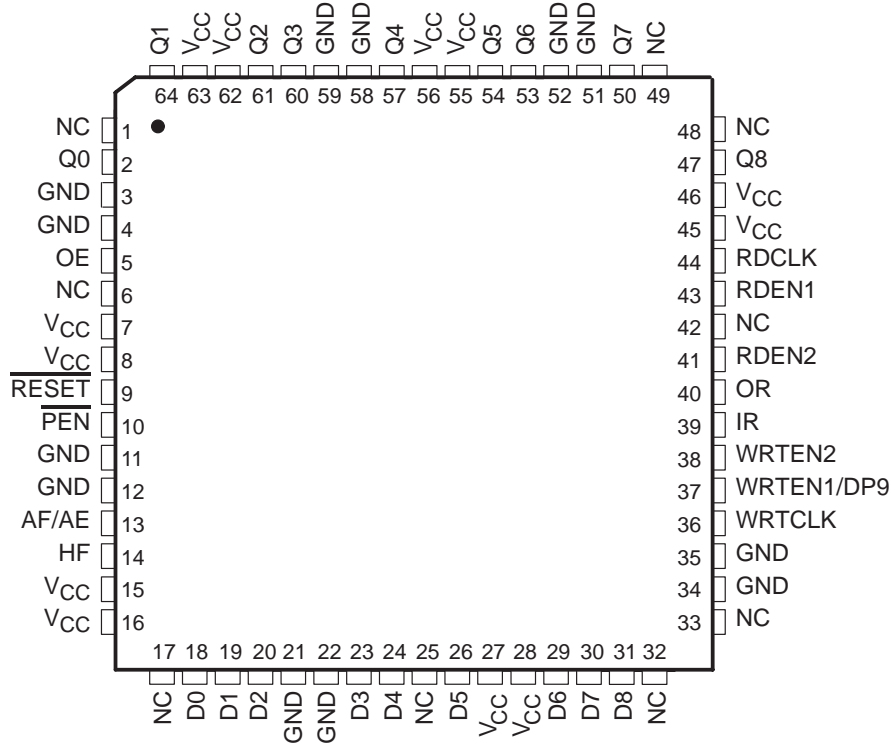

NC – No internal connection

logic symbol†

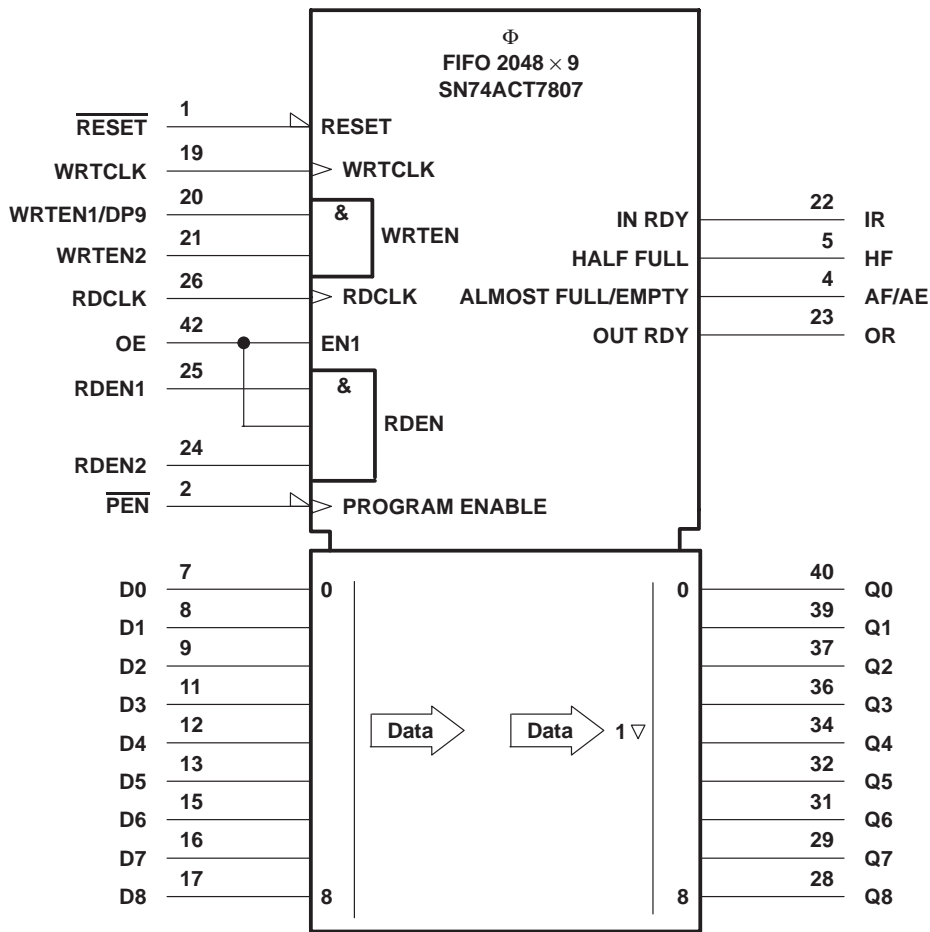

† This symbol is in accordance with ANSI/IEEE Std 91-1984 and IEC Publication 617-12. Pin numbers shown are for the FN package.

SN74ACT7807
2048 × 9
CLOCKED FIRST-IN, FIRST-OUT MEMORY

SCAS200D – JANUARY 1991 – REVISED APRIL 1998

functional block diagram

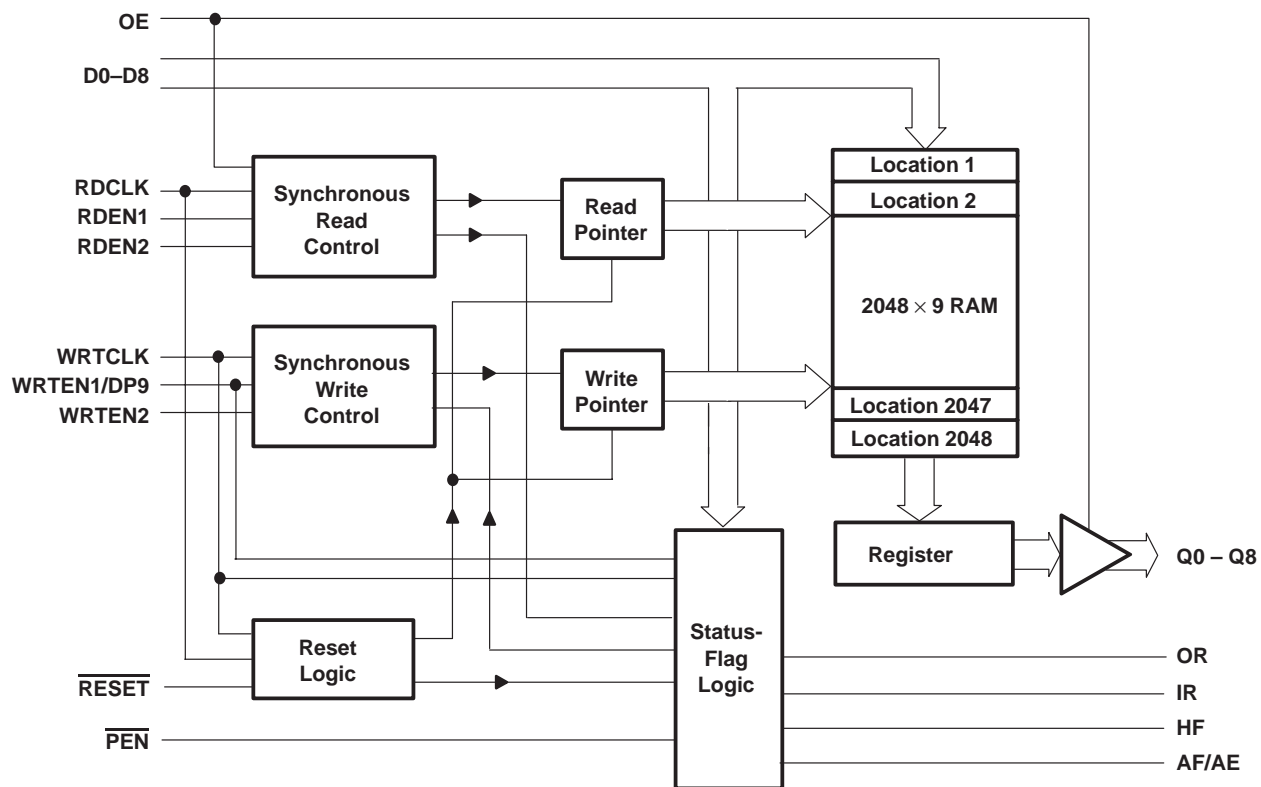

Terminal Functions

TERMINAL NAME	I/O	DESCRIPTION
AF/AE	O	Almost-full/almost-empty flag. Depth offset values can be programmed for AF/AE or the default value of 256 can be used for both the almost-empty offset (X) and the almost-full offset (Y). AF/AE is high when memory contains X or fewer words or (2048 – Y) or more words. AF/AE is high after reset.
D0–D8	I	Nine-bit data input port
HF	O	Half-full flag. HF is high when the FIFO memory contains 1024 or more words. HF is low after reset.
IR	O	Input-ready flag. IR is synchronized to the low-to-high transition of WRTCLK. When IR is low, the FIFO is full and writes are disabled. IR is low during reset and goes high on the second low-to-high transition of WRTCLK after reset.
OE	I	Output enable. When OE, RDEN1, RDEN2 and OR are high, data is read from the FIFO on a low-to-high transition of RDCLK. When OE is low, reads are disabled and the data outputs are in the high-impedance state.
OR	O	Output-ready flag. OR is synchronized to the low-to-high transition of RDCLK. When OR is low, the FIFO is empty and reads are disabled. Ready data is present on Q0–Q17 when OR is high. OR is low during reset and goes high on the third low-to-high transition of RDCLK after the first word is loaded to empty memory.
$\overline{\text{PEN}}$	I	Program enable. After reset and before the first word is written to the FIFO, the binary value on D0–D8 and DP9 is latched as an AF/AE offset value when $\overline{\text{PEN}}$ is low and WRTCLK is high.
Q0–Q8	O	Nine-bit data output port. After the first valid write to empty memory, the first word is output on Q0–Q8 on the third rising edge of RDCLK. OR also is asserted high at this time to indicate ready data. When OR is low, the last word read from the FIFO is present on Q0–Q8.
RDCLK	I	Read clock. RDCLK is a continuous clock and can be asynchronous or coincident to WRTCLK. A low-to-high transition of RDCLK reads data from memory when RDEN1, RDEN2, OE, and OR are high. OR is synchronous to the low-to-high transition of RDCLK.
RDEN1 RDEN2	I	Read enables. When RDEN1, RDEN2, OE, and OR are high, data is read from the FIFO on the low-to-high transition of RDCLK.
$\overline{\text{RESET}}$	I	Reset. To reset the FIFO, four low-to-high transitions of RDCLK and four low-to-high transitions of WRTCLK must occur while $\overline{\text{RESET}}$ is low. This sets HF, IR, and OR low and AF/AE high.
WRTCLK	I	Write clock. WRTCLK is a continuous clock and can be asynchronous or coincident to RDCLK. A low-to-high transition of WRTCLK writes data to memory when WRTEN1/DP9, WRTEN2, and IR are high. IR is synchronous to the low-to-high transition of WRTCLK.
WRTEN1/DP9	I	Write enable/data pin 9. When WRTEN1/DP9, WRTEN2, and IR are high, data is written to the FIFO on a low-to-high transition of WRTCLK. When programming an AF/AE offset value, WRTEN1/DP9 is used as the most-significant data bit.
WRTEN2	I	Write enable. When WRTEN1/DP9, WRTEN2, and IR are high, data is written to the FIFO on a low-to-high transition of WRTCLK.

offset values for AF/AE

The AF/AE flag has two programmable limits: the almost-empty offset value (X) and the almost-full offset value (Y). They can be programmed after the FIFO is reset and before the first word is written to memory. If the offsets are not programmed, the default values of X = Y = 256 are used. The AF/AE flag is high when the FIFO contains X or fewer words or (2048 – Y) or more words.

Program enable (\overline{PEN}) should be held high throughout the reset cycle. \overline{PEN} can be brought low only when IR is high and WRTCLK is low. On the following low-to-high transition of WRTCLK, the binary value on D0–D8 and WRTEN1/DP9 is stored as the almost-empty offset value (X) and the almost-full offset value (Y). Holding \overline{PEN} low for another low-to-high transition of WRTCLK reprograms Y to the binary value on D0–D8 and WRTEN1/DP9 at the time of the second WRTCLK low-to-high transition. While the offsets are programmed, data is not written to the FIFO memory, regardless of the state of the write enables (WRTEN1/DP9, WRTEN2). A maximum value of 1023 can be programmed for either X or Y (see Figure 1). To use the default values of X = Y = 256, \overline{PEN} must be held high.

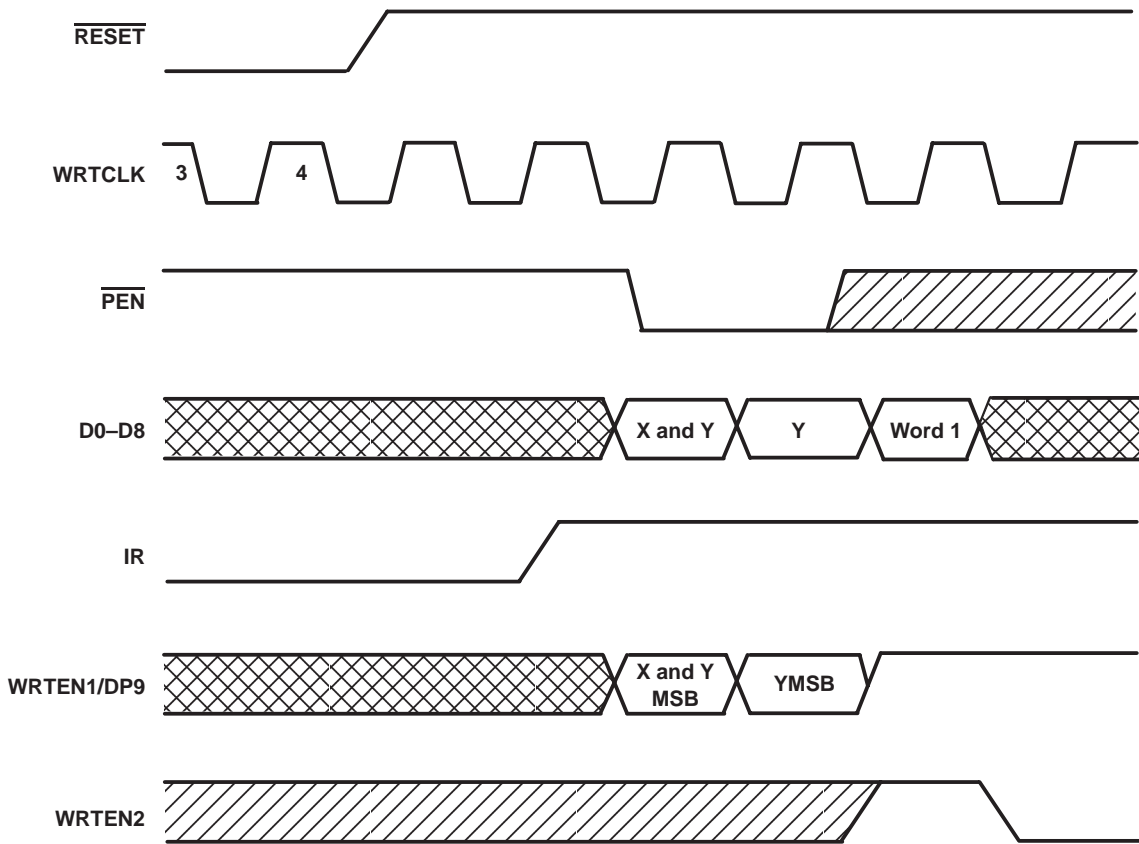
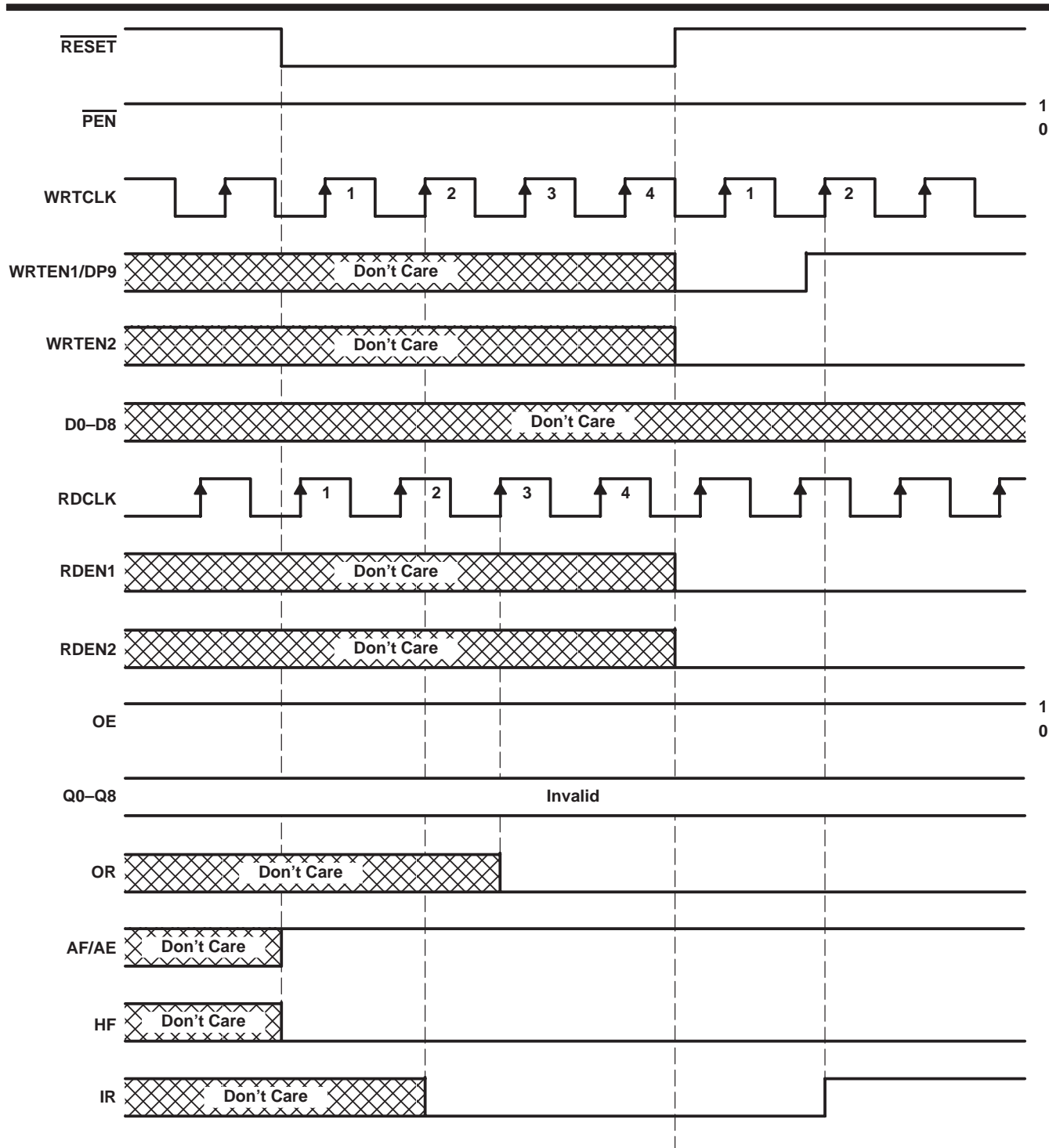

Figure 1. Programming X and Y Separately



Define the AF/AE Flag Using the Default Value of X = Y = 256

Figure 2. Reset Cycle

SN74ACT7807
 2048 × 9
 CLOCKED FIRST-IN, FIRST-OUT MEMORY
 SCAS200D – JANUARY 1991 – REVISED APRIL 1998

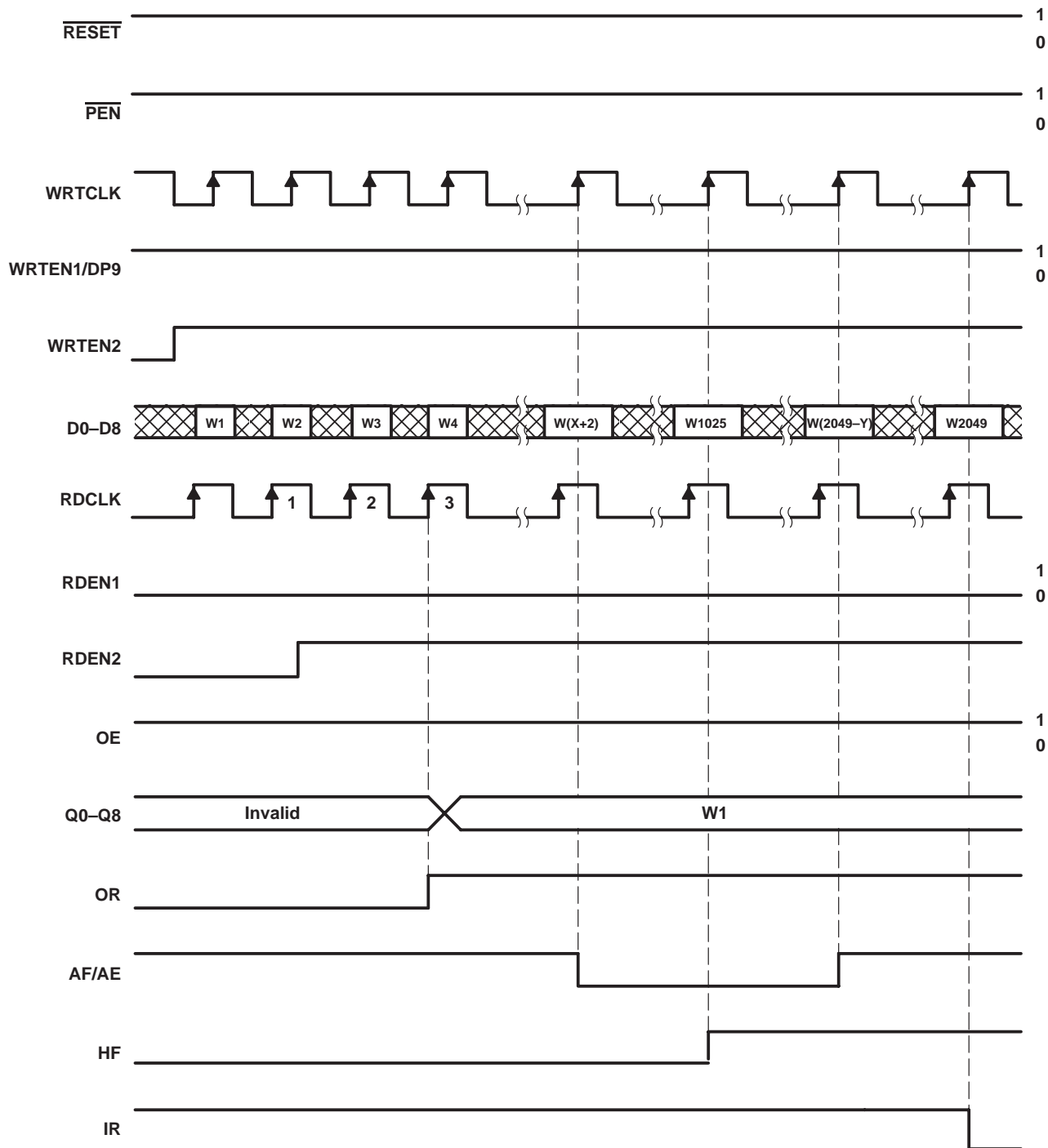

Figure 3. Write Cycle

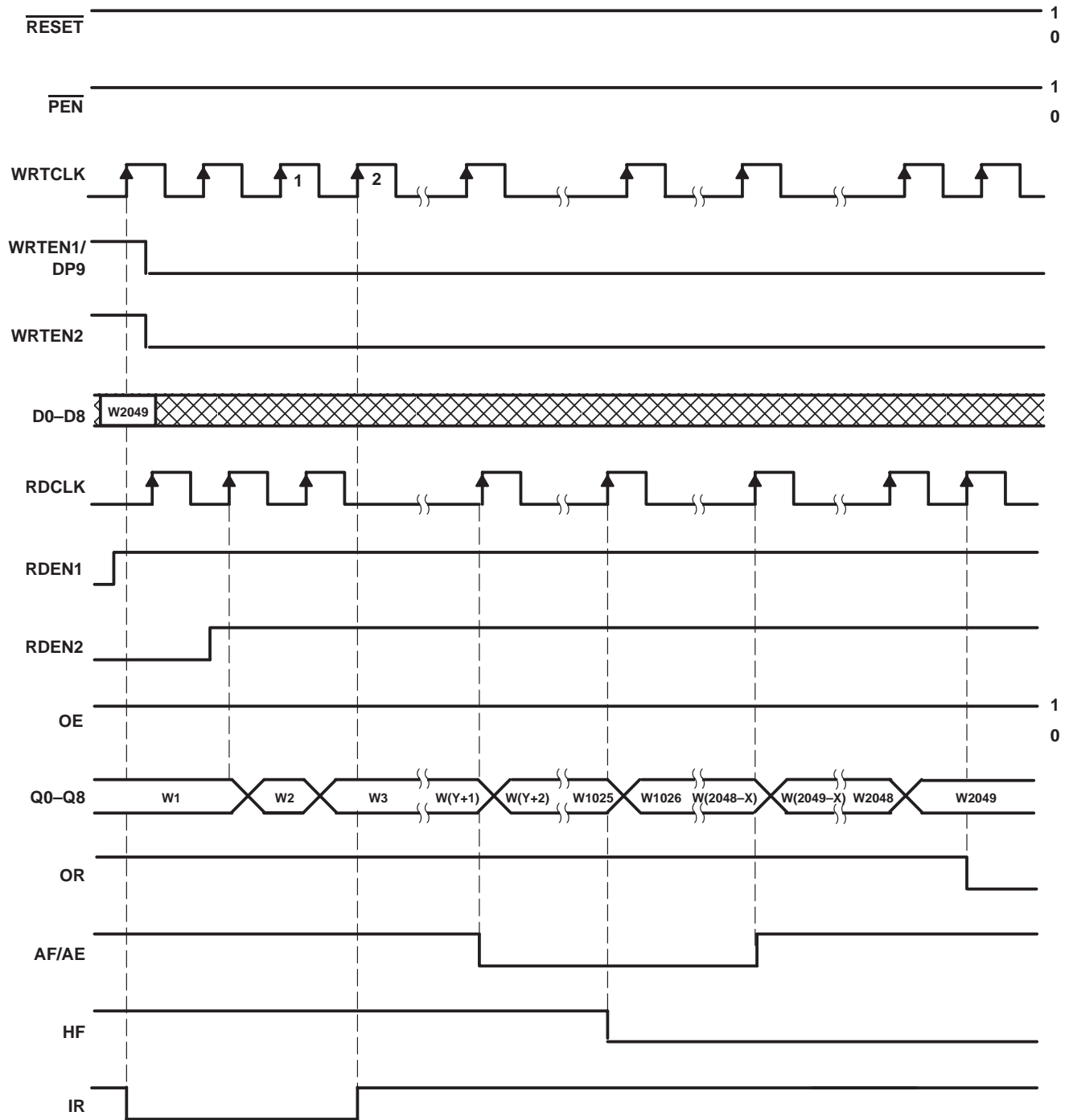

Figure 4. Read Cycle

absolute maximum ratings over operating free-air temperature range (unless otherwise noted)†

Supply voltage range, V_{CC}	-0.5 V to 7 V
Input voltage range, V_I	-0.5 V to 7 V
Voltage range applied to a disabled 3-state output	-0.5 V to 5.5 V
Package thermal impedance, θ_{JA} (see Note 1): FN package	46°C/W
PAG package	58°C/W
PM package	67°C/W
Storage temperature range, T_{stg}	-65°C to 150°C

† Stresses beyond those listed under “absolute maximum ratings” may cause permanent damage to the device. These are stress ratings only, and functional operation of the device at these or any other conditions beyond those indicated under “recommended operating conditions” is not implied. Exposure to absolute-maximum-rated conditions for extended periods may affect device reliability.

NOTE 1: The package thermal impedance is calculated in accordance with JESD 51.

recommended operating conditions

		'ACT7807-15		'ACT7807-20		'ACT7807-25		'ACT7807-40		UNIT
		MIN	MAX	MIN	MAX	MIN	MAX	MIN	MAX	
V_{CC}	Supply voltage	4.5	5.5	4.5	5.5	4.5	5.5	4.5	5.5	V
V_{IH}	High-level input voltage	2		2		2		2		V
V_{IL}	Low-level input voltage		0.8		0.8		0.8		0.8	V
I_{OH}	High-level output current	Q outputs, flags		-8	-8	-8	-8	-8	-8	mA
I_{OL}	Low-level output current	Q outputs		16	16	16	16	16	16	mA
		Flags		8	8	8	8	8	8	
T_A	Operating free-air temperature	0	70	0	70	0	70	0	70	°C

electrical characteristics over recommended operating free-air temperature range (unless otherwise noted)

PARAMETER	TEST CONDITIONS	MIN	TYP‡	MAX	UNIT
V_{OH}	$V_{CC} = 4.5\text{ V}$, $I_{OH} = -8\text{ mA}$	2.4			V
V_{OL}	Flags	$V_{CC} = 4.5\text{ V}$, $I_{OL} = 8\text{ mA}$		0.5	V
	Q outputs	$V_{CC} = 4.5\text{ V}$, $I_{OL} = 16\text{ mA}$		0.5	
I_I	$V_{CC} = 5.5\text{ V}$, $V_I = V_{CC}$ or 0			±5	µA
I_{OZ}	$V_{CC} = 5.5\text{ V}$, $V_O = V_{CC}$ or 0			±5	µA
I_{CC}	$V_{CC} = 5.5\text{ V}$, $V_I = V_{CC} - 0.2\text{ V}$ or 0			400	µA
ΔI_{CC} §	WRTEN1/DP9	$V_{CC} = 5.5\text{ V}$, One input at 3.4 V, Other inputs at V_{CC} or GND		2	mA
	Other inputs			1	
C_i	$V_I = 0$, $f = 1\text{ MHz}$			4	pF
C_o	$V_O = 0$, $f = 1\text{ MHz}$			8	pF

‡ All typical values are at $V_{CC} = 5\text{ V}$, $T_A = 25^\circ\text{C}$.

§ This is the supply current for each input that is at one of the specified TTL voltage levels rather 0 V or V_{CC} .

timing requirements over recommended operating free-air temperature range (unless otherwise noted) (see Figures 1 through 5)

		'ACT7807-15		'ACT7807-20		'ACT7807-25		'ACT7807-40		UNIT
		MIN	MAX	MIN	MAX	MIN	MAX	MIN	MAX	
f_{clock}	Clock frequency	67		50		40		25		MHz
t_w	Pulse duration	WRTCLK high or low		6	8	9	13			ns
		RDCLK high or low		6	8	9	13			
		$\overline{\text{PEN}}$ low		6	9	9	13			
t_{su}	Setup time	D0–D8 before WRTCLK \uparrow		4	5	5	5			ns
		WRTE1, WRTE2 before WRTCLK \uparrow		4	5	5	5			
		OE, RDEN1, RDEN2 before RDCLK \uparrow		5	6	6	6.5			
		Reset: $\overline{\text{RESET}}$ low before first WRTCLK \uparrow and RDCLK \uparrow		7	8	8	8			
		$\overline{\text{PEN}}$ before WRTCLK \uparrow		4	5	5	5			
t_h	Hold time	D0–D8 after WRTCLK \uparrow		0	0	0	0			ns
		WRTE1, WRTE2 after WRTCLK \uparrow		0	0	0	0			
		OE, RDEN1, RDEN2 after RDCLK \uparrow		0	0	0	0			
		Reset: $\overline{\text{RESET}}$ low after fourth WRTCLK \uparrow and RDCLK \uparrow		5	5	5	5			
		$\overline{\text{PEN}}$ high after WRTCLK \downarrow		0	0	0	0			
		$\overline{\text{PEN}}$ low after WRTCLK \uparrow		3	3	3	3			

† To permit the clock pulse to be utilized for reset purposes

switching characteristics over recommended ranges of supply voltage and operating free-air temperature, $C_L = 50$ pF (unless otherwise noted) (see Figure 5)

PARAMETER	FROM (INPUT)	TO (OUTPUT)	'ACT7807-15			'ACT7807-20		'ACT7807-25		'ACT7807-40		UNIT
			MIN	TYP \ddagger	MAX	MIN	MAX	MIN	MAX	MIN	MAX	
f_{max}	WRTCLK or RDCLK		67			50		40		25		MHz
t_{pd}	RDCLK \uparrow	Any Q	3	9	12	3	13	3	18	3	25	ns
t_{pd}^{\S}	RDCLK \uparrow	Any Q	8									ns
t_{pd}	WRTCLK \uparrow	IR	1		9	1	12	1	14	1	16	ns
	RDCLK \uparrow	OR	1		9	2	12	2	14	2	16	
	WRTCLK \uparrow	AF/AE	2		16	2	20	2	25	2	30	
	RDCLK \uparrow		2		17	2	20	2	25	2	30	
t_{PLH}	WRTCLK \uparrow	HF	2		19	2	21	2	23	2	25	ns
t_{PHL}	RDCLK \uparrow	HF	2		16	2	18	2	20	2	22	ns
t_{PLH}	$\overline{\text{RESET}}$ low	AF/AE	1		12	1	18	1	22	1	24	ns
t_{PHL}	$\overline{\text{RESET}}$ low	HF	2		12	2	18	2	22	2	24	ns
t_{en}	OE	Any Q	2		10	2	13	2	15	2	18	ns
t_{dis}	OE	Any Q	1		11	1	13	1	15	1	18	ns

\ddagger All typical values are at $V_{CC} = 5$ V, $T_A = 25^\circ\text{C}$.

\S This parameter is measured with $C_L = 30$ pF (see Figure 6).

operating characteristics, $V_{CC} = 5\text{ V}$, $T_A = 25^\circ\text{C}$

PARAMETER		TEST CONDITIONS	TYP	UNIT
C_{pd}	Power dissipation capacitance per FIFO channel	Outputs enabled	91	pF

PARAMETER MEASUREMENT INFORMATION

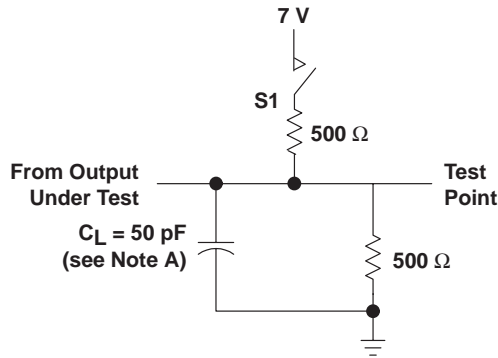

LOAD CIRCUIT

PARAMETER	S1	
t_{en}	t_{pZH}	Open
	t_{pZL}	Closed
t_{dis}	t_{pHZ}	Open
	t_{pLZ}	Closed
t_{pd}	t_{pLH}	Open
	t_{pHL}	Open

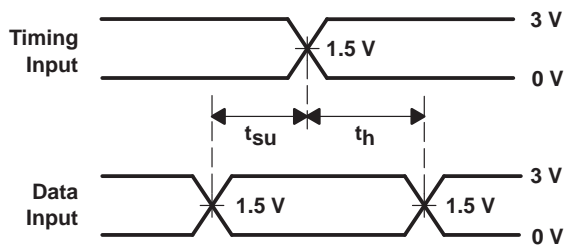

VOLTAGE WAVEFORMS
 SETUP AND HOLD TIMES

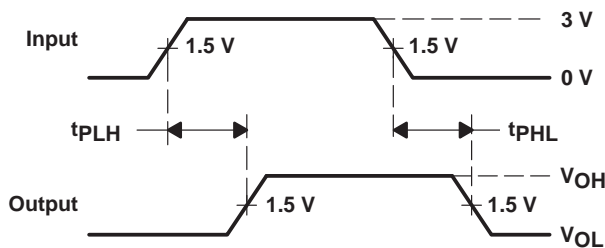

VOLTAGE WAVEFORMS
 PROPAGATION DELAY TIMES

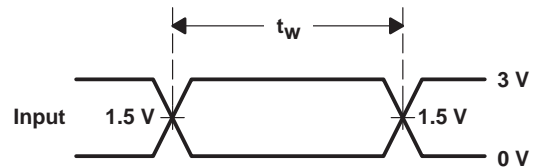

VOLTAGE WAVEFORMS
 PULSE DURATION

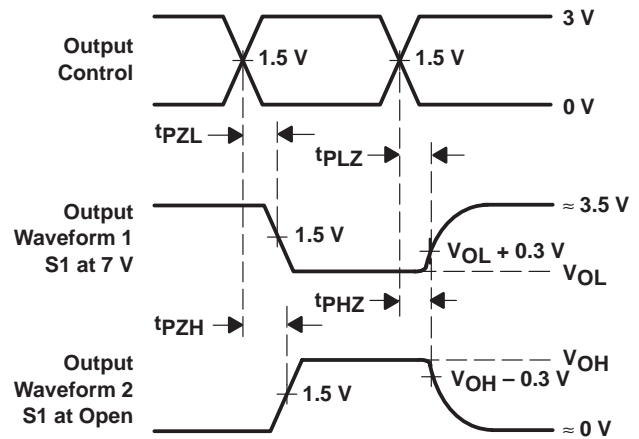

VOLTAGE WAVEFORMS
 ENABLE AND DISABLE TIMES

NOTE A: C_L includes probe and jig capacitance.

Figure 5. Load Circuit and Voltage Waveforms

TYPICAL CHARACTERISTICS

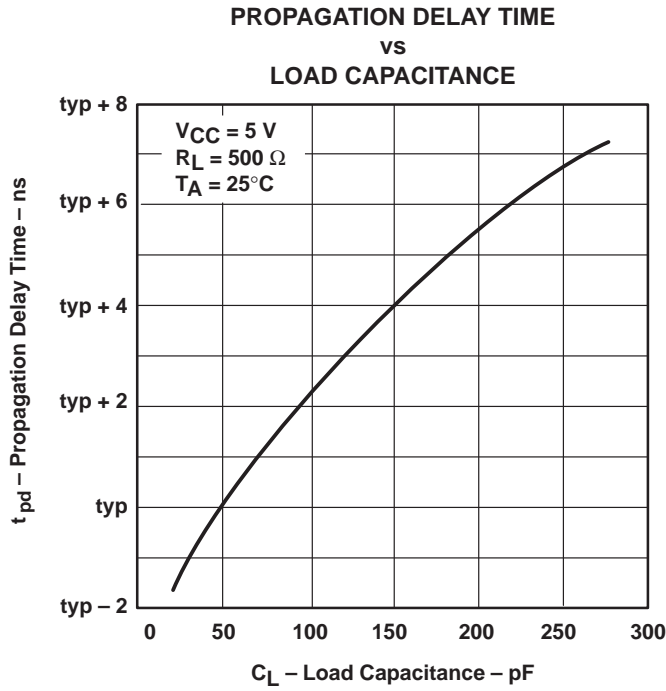

Figure 6

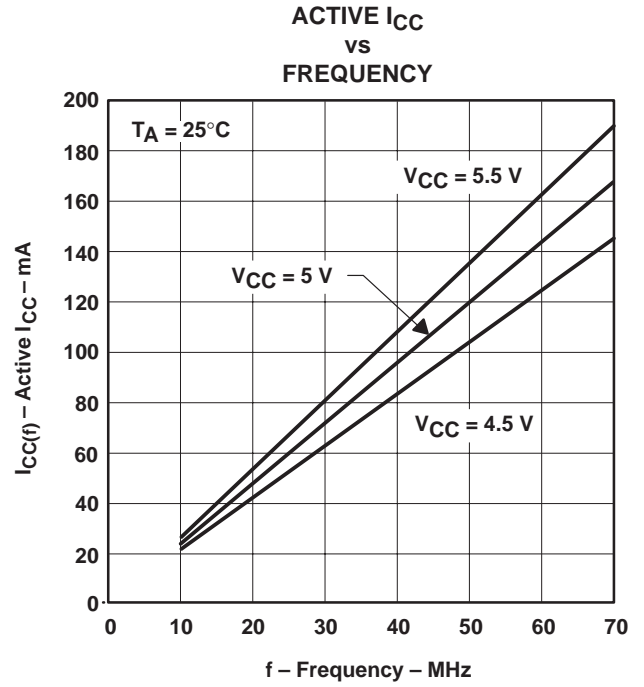
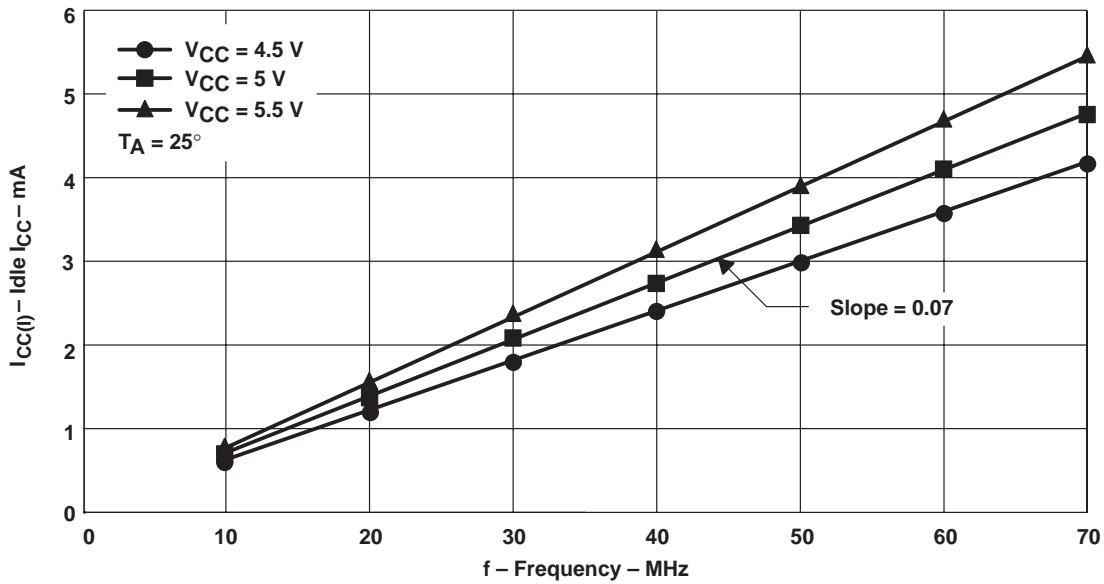

Figure 7



**Figure 8. SN74ACT7807 Idle I_{CC} With WRTCLK Switching,
Other Inputs at 0 or $V_{CC} - 0.2\text{ V}$ and Outputs Disconnected**

APPLICATION INFORMATION

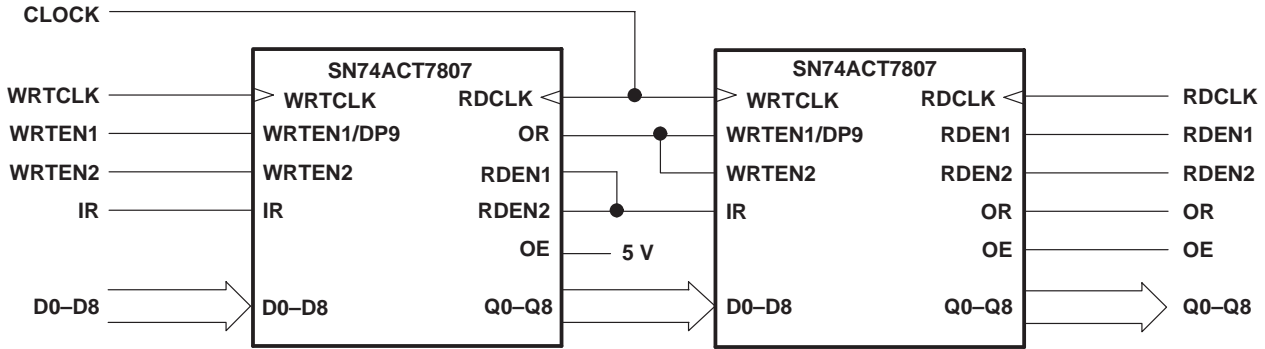

Figure 9. Word-Depth Expansion: 4096 × 9 Bits

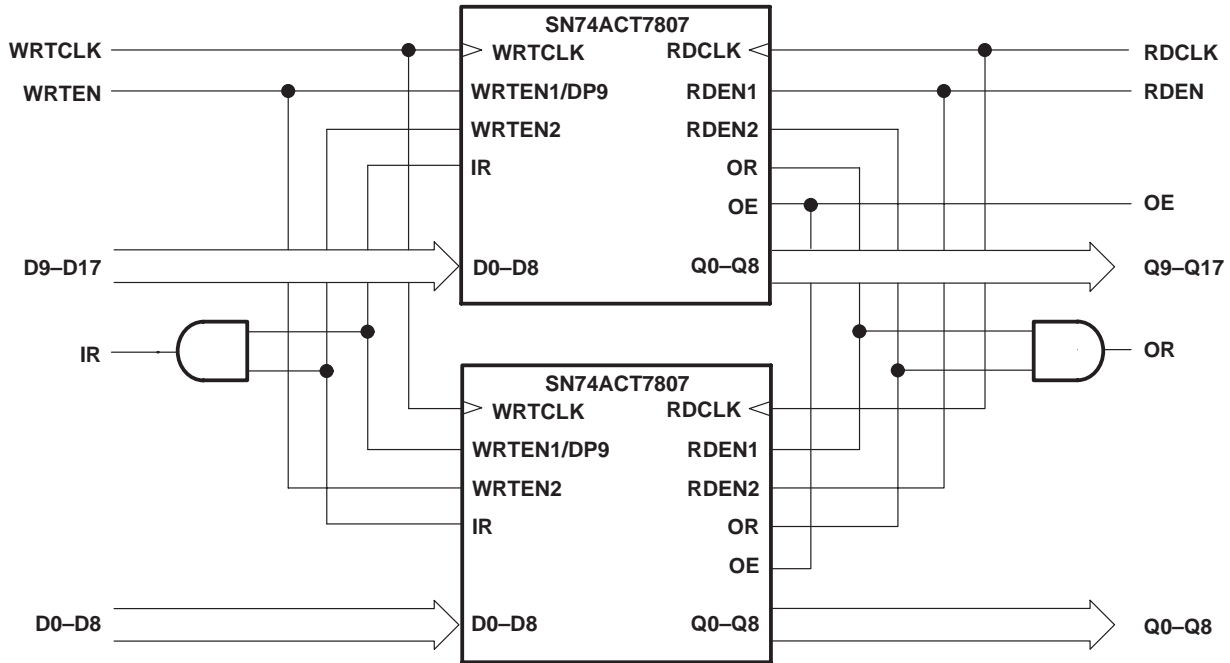

Figure 10. Word-Width Expansion: 2048 × 18 Bits

IMPORTANT NOTICE

Texas Instruments and its subsidiaries (TI) reserve the right to make changes to their products or to discontinue any product or service without notice, and advise customers to obtain the latest version of relevant information to verify, before placing orders, that information being relied on is current and complete. All products are sold subject to the terms and conditions of sale supplied at the time of order acknowledgement, including those pertaining to warranty, patent infringement, and limitation of liability.

TI warrants performance of its semiconductor products to the specifications applicable at the time of sale in accordance with TI's standard warranty. Testing and other quality control techniques are utilized to the extent TI deems necessary to support this warranty. Specific testing of all parameters of each device is not necessarily performed, except those mandated by government requirements.

CERTAIN APPLICATIONS USING SEMICONDUCTOR PRODUCTS MAY INVOLVE POTENTIAL RISKS OF DEATH, PERSONAL INJURY, OR SEVERE PROPERTY OR ENVIRONMENTAL DAMAGE ("CRITICAL APPLICATIONS"). TI SEMICONDUCTOR PRODUCTS ARE NOT DESIGNED, AUTHORIZED, OR WARRANTED TO BE SUITABLE FOR USE IN LIFE-SUPPORT DEVICES OR SYSTEMS OR OTHER CRITICAL APPLICATIONS. INCLUSION OF TI PRODUCTS IN SUCH APPLICATIONS IS UNDERSTOOD TO BE FULLY AT THE CUSTOMER'S RISK.

In order to minimize risks associated with the customer's applications, adequate design and operating safeguards must be provided by the customer to minimize inherent or procedural hazards.

TI assumes no liability for applications assistance or customer product design. TI does not warrant or represent that any license, either express or implied, is granted under any patent right, copyright, mask work right, or other intellectual property right of TI covering or relating to any combination, machine, or process in which such semiconductor products or services might be or are used. TI's publication of information regarding any third party's products or services does not constitute TI's approval, warranty or endorsement thereof.

Looking for pricing, stock, or lifecycle information?

Click below to explore more details on WIN SOURCE:

 [View SN74ACT7807-25FN on WIN SOURCE](#)

 [Texas Instruments](#) Information

Optimize Your Supply Chain with WIN SOURCE Solutions

-  Global Sourcing Solution
-  Obsolete Management
-  Cost Control Management
-  Shortage Management
-  Alternative Solution
-  Excess Inventory Management