



**THE DATASHEET OF
AT93C86A-10SU-1.8**



3-wire Serial EEPROM
16K (2,048 x 8 or 1,024 x 16)

DATASHEET

Features

- Low-voltage Operation
 - $V_{CC} = 1.8V$ to 5.5V
 - $V_{CC} = 2.7V$ to 5.5V
- User-selectable Internal Organization
 - 16K: 2,048 x 8 or 1,024 x 16
- 3-wire Serial Interface
- Sequential Read Operation
- Schmitt Trigger, Filtered Inputs for Noise Suppression
- 2MHz Clock Rate (5V)
- Self-timed Write Cycle (10ms Max)
- High Reliability
 - Endurance: 1,000,000 Write Cycles
 - Data Retention: 100 Years
- 8-lead JEDEC SOIC, 8-lead TSSOP, 8-pad UDFN, and 8-lead PDIP Packages

Description

The Atmel® AT93C86A provides 16,384 bits of Serial Electrically Erasable Programmable Read-Only Memory (EEPROM) organized as 1,024 words of 16 bits each (when the ORG pin is connected to V_{CC}) and 2,048 words of 8 bits each (when the ORG pin is tied to ground). The device is optimized for use in many industrial and commercial applications where low-power and low-voltage operations are essential. The AT93C86A is available in space-saving 8-lead JEDEC SOIC, 8-lead TSSOP, 8-pad UDFN, and 8-lead PDIP packages.

The AT93C86A is enabled through the Chip Select pin (CS) and accessed via a 3-wire serial interface consisting of Data Input (DI), Data Output (DO), and Shift Clock (SK). Upon receiving a Read instruction at DI, the address is decoded, and the data is clocked out serially on the DO pin. The write cycle is completely self-timed, and no separate erase cycle is required before Write. The write cycle is only enabled when the part is in the Erase/Write Enable state. When CS is brought high following the initiation of a write cycle, the DO pin outputs the Ready/Busy status of the part.

The AT93C86A operates from 1.8V to 5.5V or from 2.7V to 5.5V.

1. Pin Configurations and Pinouts

Table 1-1. Pin Configurations

Pin Name	Function
CS	Chip Select
SK	Serial Data Clock
DI	Serial Data Input
DO	Serial Data Output
GND	Ground
V _{CC}	Power Supply
ORG	Internal Organization
NC	No Connect

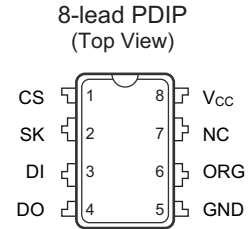
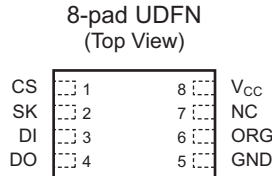
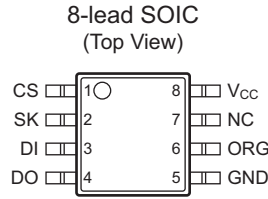

Note: Drawings are not to scale.

2. Absolute Maximum Ratings*

Operating Temperature	-55°C to +125°C
Storage Temperature	-65°C to +150°C
Voltage on any pin with respect to ground	-1.00V to +7.00V
Maximum Operating Voltage	6.25V
DC Output Current	5.0mA

*Notice: Stresses beyond those listed under “Absolute Maximum Ratings” may cause permanent damage to the device. This is a stress rating only, and functional operation of the device at these or any other conditions beyond those indicated in the operational sections of this specification is not implied. Exposure to absolute maximum rating conditions for extended periods may affect device reliability.

3. Block Diagram

Figure 3-1. Block Diagram

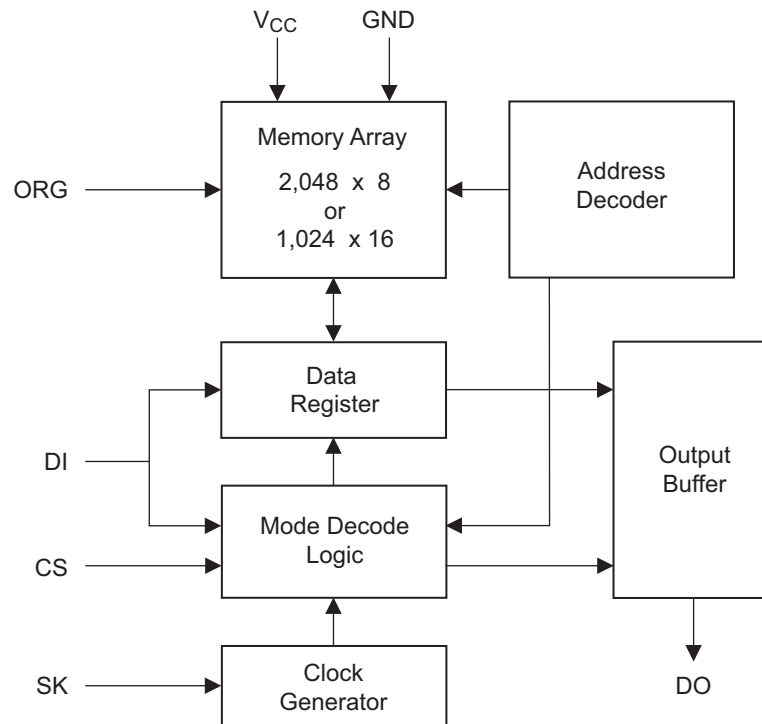

Note: When the ORG pin is connected to V_{CC} , the x16 organization is selected. When it is connected to ground, the x8 organization is selected. If the ORG pin is left unconnected, and the application does not load the input beyond the capability of the internal $1M\Omega$ pull-up resistor, then the x16 organization is selected.

4. Memory Organization

4.1 Pin Capacitance

Table 4-1. Pin Capacitance⁽¹⁾

Applicable over recommended operating range from $T_A = 25^\circ\text{C}$, $f = 1.0\text{MHz}$, $V_{CC} = 5.0\text{V}$ (unless otherwise noted).

Symbol	Test Conditions	Max	Units	Conditions
C_{OUT}	Output Capacitance (DO)	5	pF	$V_{OUT} = 0\text{V}$
C_{IN}	Input Capacitance (CS, SK, DI)	5	pF	$V_{IN} = 0\text{V}$

Note: 1. This parameter is characterized, and is not 100% tested.

4.2 DC Characteristics

Table 4-2. DC Characteristics

Applicable over recommended operating range from $T_{AI} = -40^\circ\text{C}$ to $+85^\circ\text{C}$, $V_{CC} = 1.8\text{V}$ to 5.5V (unless otherwise noted).

Symbol	Parameter	Test Condition	Min	Typ	Max	Unit
V_{CC1}	Supply Voltage		1.8		5.5	V
V_{CC2}	Supply Voltage		2.7		5.5	V
V_{CC3}	Supply Voltage		4.5		5.5	V
I_{CC}	Supply Current	$V_{CC} = 5.0\text{V}$	Read at 1.0MHz	0.5	2.0	mA
			Write at 1.0MHz	0.5	2.0	mA
I_{SB1}	Standby Current	$V_{CC} = 1.8\text{V}$		0.4	1.0	μA
I_{SB2}	Standby Current	$V_{CC} = 2.7\text{V}$		6.0	10.0	μA
I_{SB3}	Standby Current	$V_{CC} = 5.0\text{V}$		10.0	15.0	μA
I_{IL}	Input Leakage	$V_{IN} = 0\text{V}$ to V_{CC}		0.1	3.0	μA
I_{OL}	Output Leakage	$V_{IN} = 0\text{V}$ to V_{CC}		0.1	3.0	μA
$V_{IL1}^{(1)}$	Input Low Voltage	$2.7\text{V} \leq V_{CC} \leq 5.5\text{V}$	-0.6		0.8	V
$V_{IH1}^{(1)}$	Input High Voltage	$2.7\text{V} \leq V_{CC} \leq 5.5\text{V}$	2.0		$V_{CC} + 1$	V
$V_{IL2}^{(1)}$	Input Low Voltage	$1.8\text{V} \leq V_{CC} \leq 2.7\text{V}$	-0.6		$V_{CC} \times 0.3$	V
$V_{IH2}^{(1)}$	Input High Voltage	$1.8\text{V} \leq V_{CC} \leq 2.7\text{V}$	$V_{CC} \times 0.7$		$V_{CC} + 1$	V
V_{OL1}	Output Low Voltage	$2.7\text{V} \leq V_{CC} \leq 5.5\text{V}$			0.4	V
V_{OH1}	Output High Voltage	$2.7\text{V} \leq V_{CC} \leq 5.5\text{V}$	2.4			V
V_{OL2}	Output Low Voltage	$1.8\text{V} \leq V_{CC} \leq 2.5\text{V}$			0.2	V
V_{OH2}	Output High Voltage	$1.8\text{V} \leq V_{CC} \leq 2.7\text{V}$	$V_{CC} - 0.2$			V

Note: 1. V_{IL} min and V_{IH} max are reference only, and are not tested.

4.3 AC Characteristics

Table 4-3. AC Characteristics

Applicable over recommended operating range from $T_{AI} = -40^{\circ}\text{C}$ to $+85^{\circ}\text{C}$, $CL = 1$ TTL gate and 100pF (unless otherwise noted).

Symbol	Parameter	Test Condition	Min	Typ	Max	Units
f_{SK}	SK Clock Frequency	$4.5\text{V} \leq V_{CC} \leq 5.5\text{V}$	0		2	MHz
		$2.7\text{V} \leq V_{CC} \leq 5.5\text{V}$	0		1	MHz
		$1.8\text{V} \leq V_{CC} \leq 5.5\text{V}$	0		250	kHz
t_{SKH}	SK High Time	$2.7\text{V} \leq V_{CC} \leq 5.5\text{V}$	250			ns
		$1.8\text{V} \leq V_{CC} \leq 5.5\text{V}$	1000			ns
t_{SKL}	SK Low Time	$2.7\text{V} \leq V_{CC} \leq 5.5\text{V}$	250			ns
		$1.8\text{V} \leq V_{CC} \leq 5.5\text{V}$	1000			ns
t_{CS}	Minimum CS Low Time	$2.7\text{V} \leq V_{CC} \leq 5.5\text{V}$	250			ns
		$1.8\text{V} \leq V_{CC} \leq 5.5\text{V}$	1000			ns
t_{CSS}	CS Setup Time	Relative to SK				
		$2.7\text{V} \leq V_{CC} \leq 5.5\text{V}$	50			ns
t_{DIS}	DI Setup Time	Relative to SK				
		$1.8\text{V} \leq V_{CC} \leq 5.5\text{V}$	200			ns
t_{DIH}	DI Hold Time	Relative to SK				
		$2.7\text{V} \leq V_{CC} \leq 5.5\text{V}$	100			ns
t_{CSH}	CS Hold Time	Relative to SK				
		$1.8\text{V} \leq V_{CC} \leq 5.5\text{V}$	400			ns
t_{PD1}	Output Delay to 1	AC Test				
		$2.7\text{V} \leq V_{CC} \leq 5.5\text{V}$			250	ns
t_{PDO}	Output Delay to 0	AC Test				
		$1.8\text{V} \leq V_{CC} \leq 5.5\text{V}$			1000	ns
t_{SV}	CS to Status Valid	AC Test				
		$2.7\text{V} \leq V_{CC} \leq 5.5\text{V}$			250	ns
t_{DF}	CS to DO in High-impedance	AC Test				
		$1.8\text{V} \leq V_{CC} \leq 5.5\text{V}$			1000	ns
t_{WP}	Write Cycle Time	AC Test				
		$CS = V_{IL}$	$2.7\text{V} \leq V_{CC} \leq 5.5\text{V}$			150
t_{WP}	Write Cycle Time	AC Test				
		$CS = V_{IL}$	$1.8\text{V} \leq V_{CC} \leq 5.5\text{V}$	0.1	3	10
Endurance ⁽¹⁾	5.0V, 25°C			1,000,000		Write Cycles

Note: 1. This parameter is characterized, and is not 100% tested.

5. Functional Description

The AT93C86A is accessed via a simple and versatile 3-wire serial communication interface. Device operation is controlled by seven instructions issued by the Host processor. A valid instruction starts with a rising edge of CS and consists of a Start bit (Logic 1), followed by the appropriate opcode, and the desired memory address location.

Table 5-1. AT93C86A Instruction Set

Instruction	SB	Opcode	Address		Data		Comments
			x8 ⁽¹⁾	x16 ⁽¹⁾	x8	x16	
READ	1	10	A ₁₀ – A ₀	A ₉ – A ₀			Reads data stored in memory at specified address.
EWEN	1	00	11XXXXXXXX	11XXXXXX			Write Enable must precede all programming modes.
ERASE	1	11	A ₁₀ – A ₀	A ₉ – A ₀			Erases memory location A _N – A ₀ .
WRITE	1	01	A ₁₀ – A ₀	A ₉ – A ₀	D ₇ – D ₀	D ₁₅ – D ₀	Writes memory location A _N – A ₀ .
ERAL	1	00	10XXXXXXXX	10XXXXXX			Erases all memory locations. Valid only at V _{CC} = 4.5V to 5.5V.
WRAL	1	00	01XXXXXXXX	01XXXXXX	D ₇ – D ₀	D ₁₅ – D ₀	Writes all memory locations. Valid only at V _{CC} = 4.5V to 5.5V and Disable Register cleared.
EWDS	1	00	00XXXXXXXX	00XXXXXX			Disables all programming instructions.

Note: 1. The 'X' in the address field represent don't care values, and must be clocked.

READ: The READ instruction contains the address code for the memory location to be read. After the instruction and address are decoded, data from the selected memory location is available at the Serial Output pin, DO. Output data changes are synchronized with the rising edges of the Serial Clock pin, SK. It should be noted that a dummy bit (Logic 0) precedes the 8-bit or 16-bit data output string. The AT93C86A supports sequential Read operations. The device will automatically increment the internal address pointer and clock out the next memory location as long as Chip Select (CS) is held high. In this case, the dummy bit (Logic 0) will not be clocked out between memory locations, thus allowing for a continuous stream of data to be read.

Erase/Write Enable (EWEN): To ensure data integrity, the part automatically goes into the Erase/Write Disable (EWDS) state when power is first applied. An Erase/Write Enable (EWEN) instruction must be executed first before any programming instructions can be carried out.

Note: Once in the EWEN state, programming remains enabled until an EWDS instruction is executed, or V_{CC} power is removed from the part.

ERASE: The ERASE instruction programs all bits in the specified memory location to the Logic 1 state. The self-timed erase cycle starts once the ERASE instruction and address are decoded. The DO pin outputs the Ready/Busy status of the part if CS is brought high after being kept low for a minimum of t_{CS} . A Logic 1 at the DO pin indicates that the selected memory location has been erased, and the part is ready for another instruction.

WRITE: The WRITE instruction contains the 8-bits or 16-bits of data to be written into the specified memory location. The self-timed programming cycle, t_{WP} , starts after the last bit of data is received at Serial Data Input pin DI. The DO pin outputs the Ready/Busy status of the part if CS is brought high after being kept low for a minimum of t_{CS} . A Logic 0 at DO indicates that programming is still in progress. A Logic 1 indicates that the memory location at the specified address has been written with the data pattern contained in the instruction, and the part is ready for further instructions. A Ready/Busy status cannot be obtained if CS is brought high after the end of the self-timed programming cycle, t_{WP} .

Erase All (ERAL): The Erase All (ERAL) instruction programs every bit in the Memory Array to the Logic 1 state and is primarily used for testing purposes. The DO pin outputs the ready/busy status of the part if CS is brought high after being kept low for a minimum of t_{CS} . The ERAL instruction is valid only at $V_{CC} = 5.0V \pm 10\%$.

Write All (WRAL): The Write All (WRAL) instruction programs all memory locations with the data patterns specified in the instruction. The DO pin outputs the Ready/Busy status of the part if CS is brought high after being kept low for a minimum of t_{CS} . The WRAL instruction is valid only at $V_{CC} = 5.0V \pm 10\%$.

Erase/Write Disable (EWDS): To protect against accidental data disturbance, the Erase/Write Disable (EWDS) instruction disables all programming modes and should be executed after all programming operations. The operation of the Read instruction is independent of both the EWEN and EWDS instructions and can be executed at any time.

6. Timing Diagrams

Figure 6-1. Synchronous Data Timing

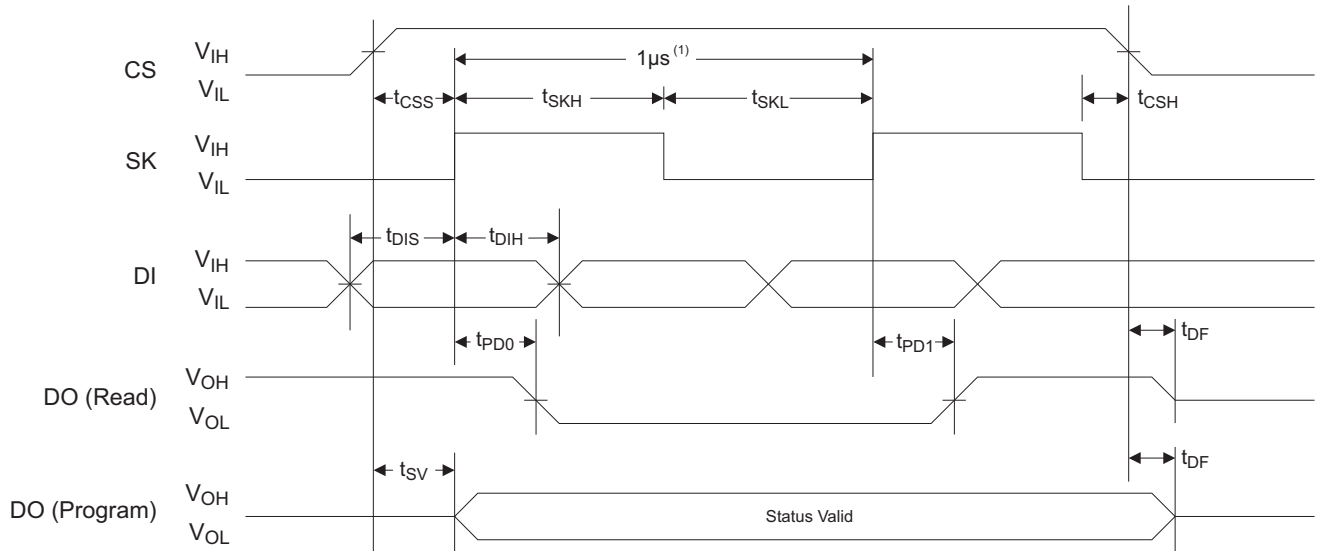

Table 6-1. Organization Key for Timing Diagrams

I/O	AT93C86A (16K)	
	x8	x16
A_N	A_{10}	A_9
D_N	D_7	D_{15}

Figure 6-2. ERASE Timing

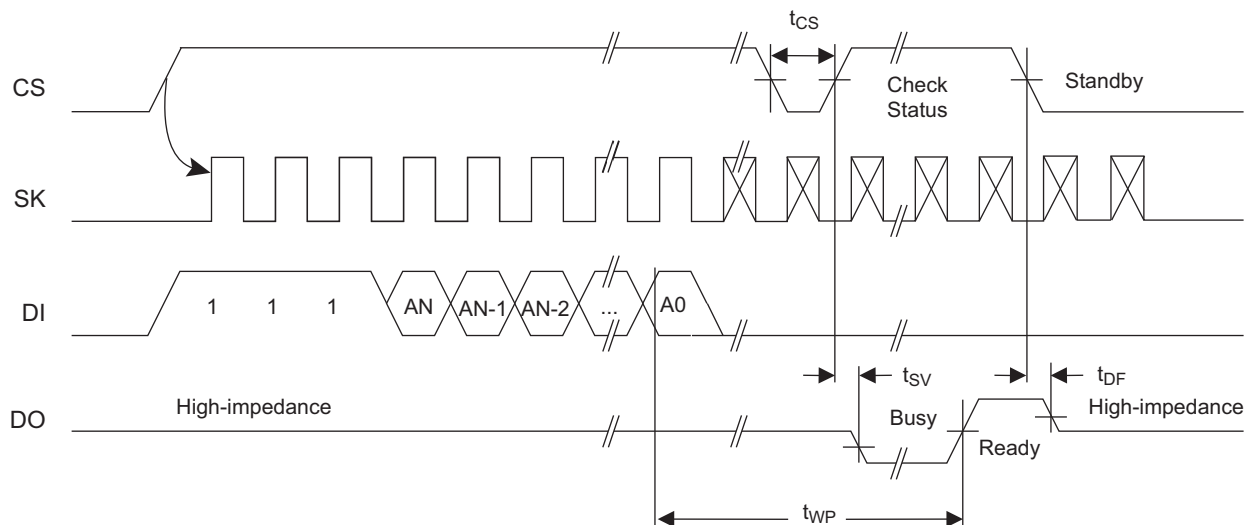

Figure 6-3. READ Timing

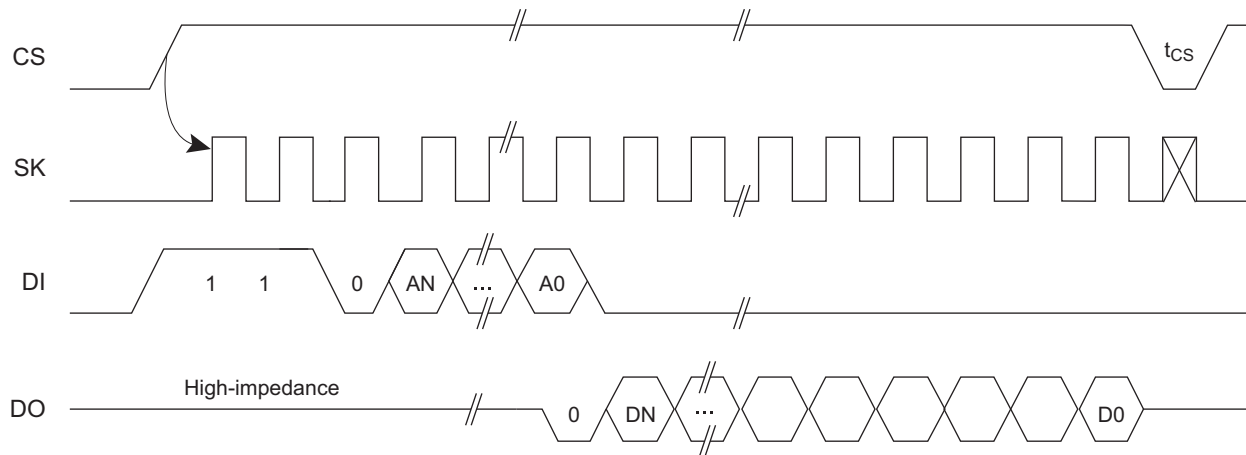

Figure 6-4. EWEN Timing

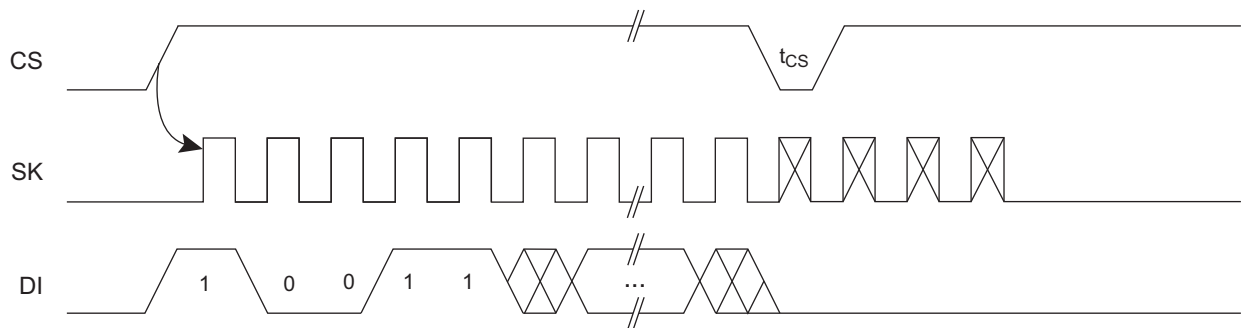

Figure 6-5. WRITE Timing

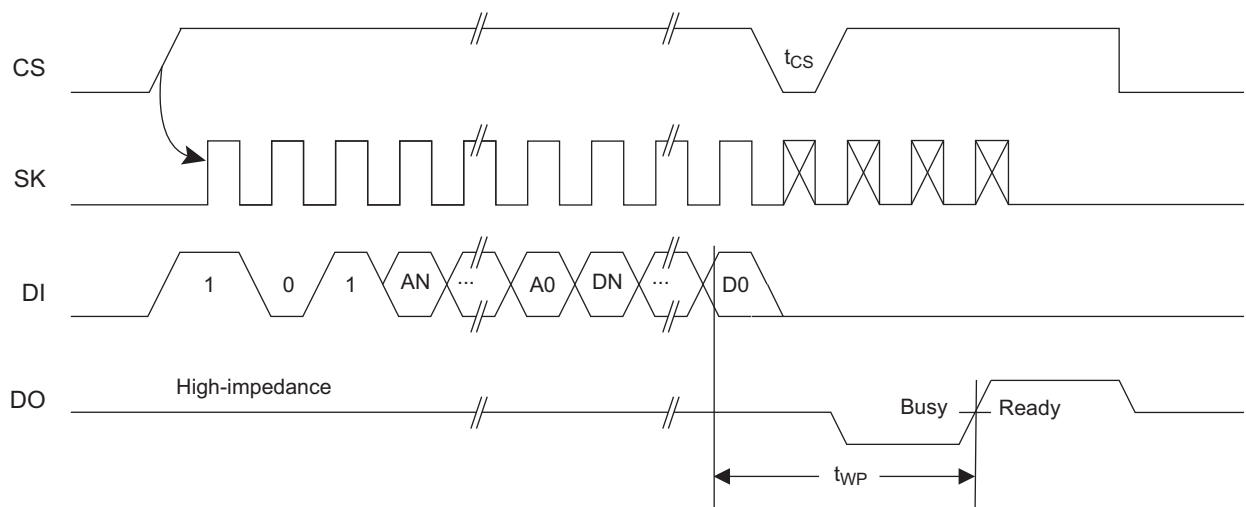
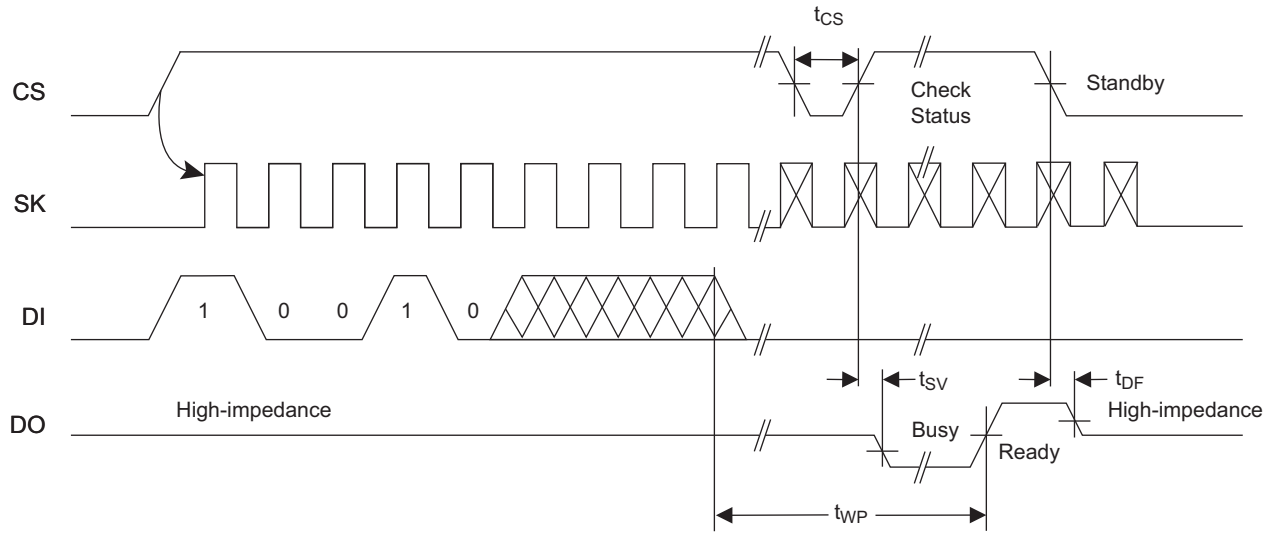
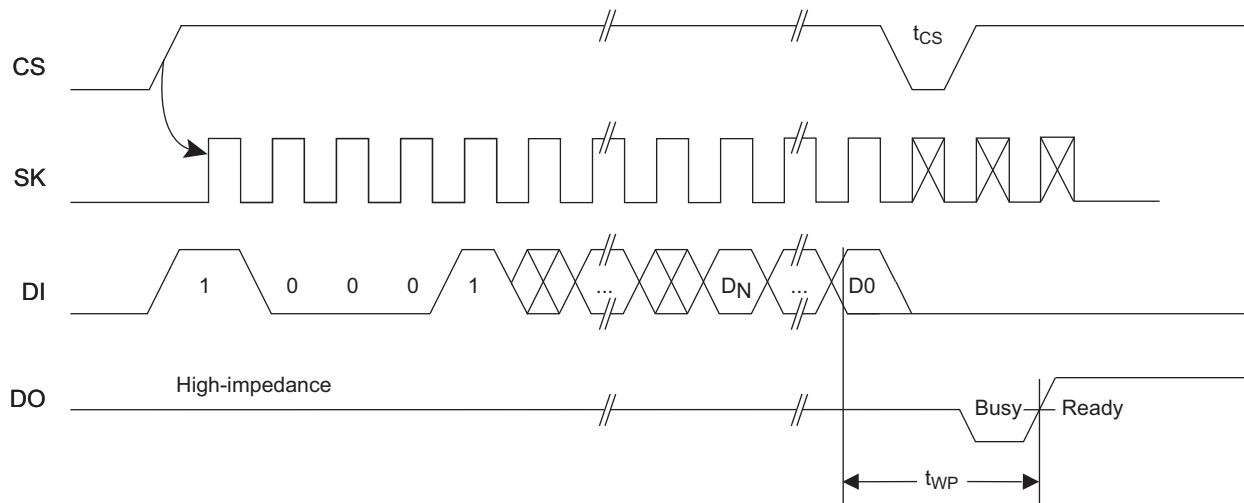

Figure 6-6. ERAL Timing⁽¹⁾



Note: 1. $V_{CC} = 4.5V$ to $5.5V$.

Figure 6-7. WRAL Timing⁽¹⁾



Note: 1. Valid only at $V_{CC} = 4.5V$ to $5.5V$.

Figure 6-8. EWDS Timing

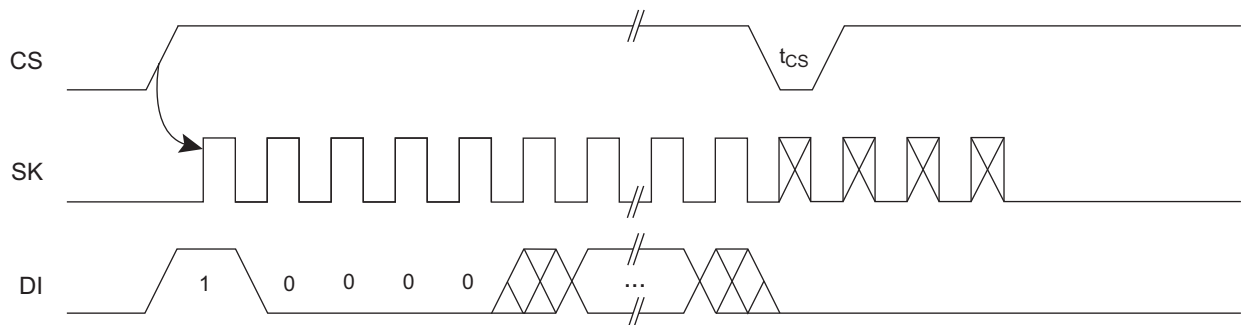

7. Ordering Code Detail

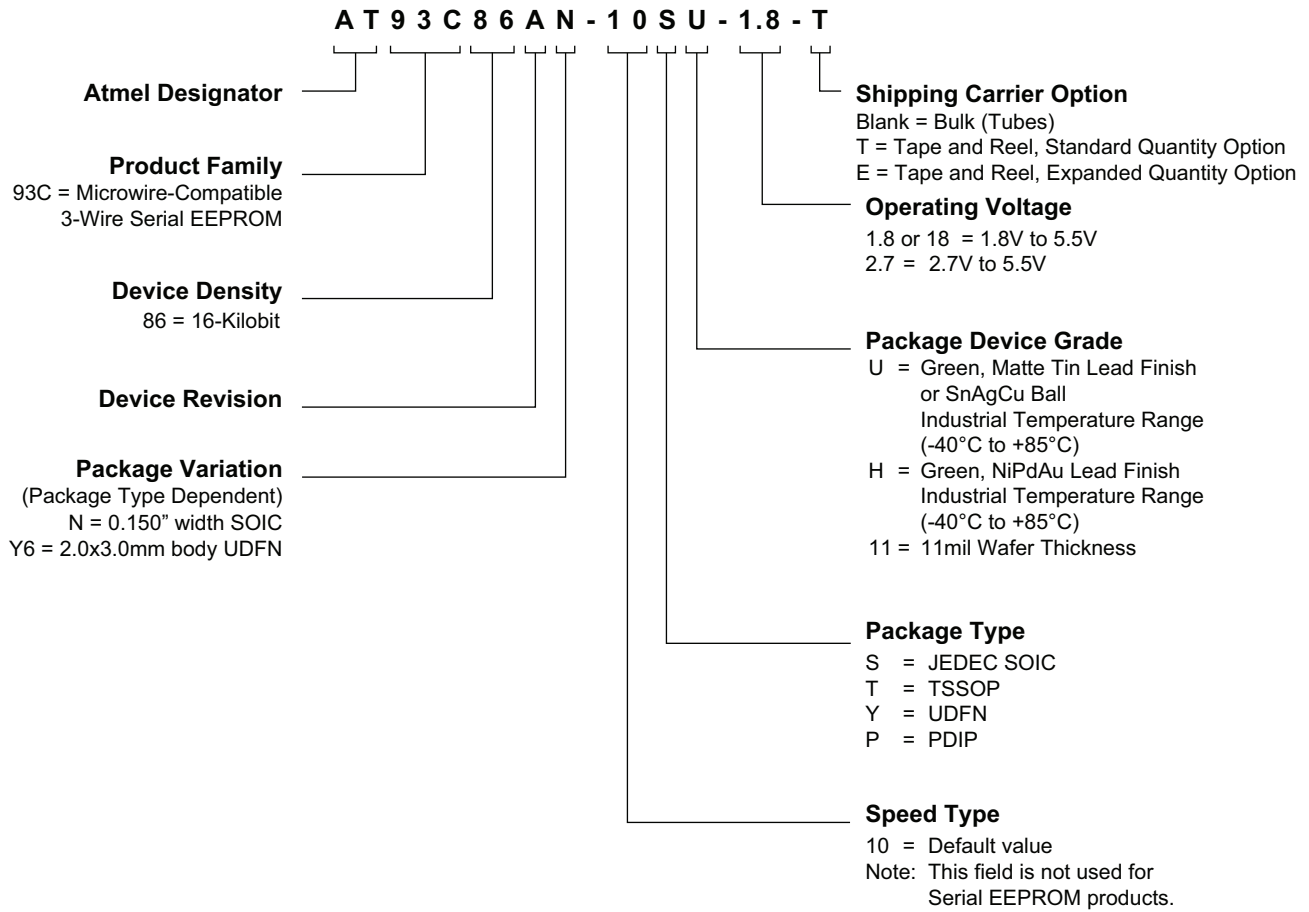

8. Part Markings

AT93C86A: Package Marking Information

8-lead SOIC	8-lead TSSOP
<p>Note: Lot Number and location of assembly on the bottom side of the package.</p>	<p>Note: Lot Number, location of assembly and YWW date code on the bottom side of the package.</p>
8-pad UDFN	8-lead PDIP
<p>2.0 x 3.0 mm Body</p>	<p>Note: Lot Number and location of assembly on the bottom side of the package.</p>

Note 1: ● designates pin 1

Note 2: Package drawings are not to scale

Catalog Number Truncation			
AT93C86A		Truncation Code ###: 86A	
Date Codes			Voltagess
Y = Year	M = Month	WW = Work Week of Assembly	% = Minimum Voltage
4: 2014 8: 2018	A: January	02: Week 2	3 or 27: 2.7V min
5: 2015 9: 2019	B: February	04: Week 4	1 or 18: 1.8V min
6: 2016 0: 2020	
7: 2017 1: 2021	L: December	52: Week 52	
Country of Assembly		Lot Number	Grade/Lead Finish Material
@ = Country of Assembly		AAA...A = Atmel Wafer Lot Number	H: Industrial/NiPdAu U: Industrial/Matte Tin/SnAgCu
Trace Code			Atmel Truncation
XX = Trace Code (Atmel Lot Numbers Correspond to Code) Example: AA, AB.... YZ, ZZ			AT: Atmel ATM: Atmel ATML: Atmel

6/11/14

<p>Package Mark Contact: DL-CSO-Assy_eng@atmel.com</p>	TITLE 93C86ASM, AT93C86A Package Marking Information	DRAWING NO. 93C86ASM	REV. A
--	---	--------------------------------	------------------

9. Ordering Information

Atmel Ordering Code ⁽¹⁾	Lead Finish	Package	Voltage	Delivery Information		Operation Range
				Form	Quantity	
AT93C86A-10SU-1.8	Matte Tin Lead-free Halogen-free	8S1	1.8V to 5.5V	Bulk (Tubes)	100 per Tube	Industrial Temperature (-40°C to 85°C)
AT93C86A-10SU-1.8-T			1.8V to 5.5V	Tape and Reel	4,000 per Reel	
AT93C86A-10SU-2.7			2.7V to 5.5V ⁽¹⁾	Bulk (Tubes)	100 per Tube	
AT93C86A-10SU-2.7-T			2.7V to 5.5V ⁽¹⁾	Tape and Reel	4,000 per Reel	
AT93C86A-10TU-1.8		8X	1.8V to 5.5V	Bulk (Tubes)	100 per Tube	
AT93C86A-10TU-1.8-T			1.8V to 5.5V	Tape and Reel	5,000 per Reel	
AT93C86A-10TU-2.7			2.7V to 5.5V ⁽¹⁾	Bulk (Tubes)	100 per Tube	
AT93C86A-10TU-2.7-T			2.7V to 5.5V ⁽¹⁾	Tape and Reel	5,000 per Reel	
AT93C86A-10PU-1.8		8P3	1.8V to 5.5V	Bulk (Tubes)	50 per Tube	
AT93C86A-10PU-2.7			2.7V to 5.5V ⁽¹⁾	Bulk (Tubes)	50 per Tube	
AT93C86AY6-10YH-1.8-T	NiPdAu Lead-free Halogen-free	8MA2	1.8V to 5.5V	Tape and Reel	5,000 per Reel	
AT93C86AY6-10YH-18-E				Tape and Reel	15,000 per Reel	

Notes: 1. For 2.7V devices used in a 4.5V to 5.5V range, please refer to performance values in [Section 4.2, "DC Characteristics"](#) and [4.3, "AC Characteristics"](#) on page 5.

Package Type	
8S1	8-lead, 0.150" wide, Plastic Gull Wing, Small Outline (JEDEC SOIC)
8X	8-lead, 0.170" wide, Thin Shrink Small Outline (TSSOP)
8P3	8-lead, 0.300" wide body, Plastic Dual In-line Package (PDIP)
8MA2	8-pad, 2.00mm x 3.00mm body, 0.50mm pitch, Ultra Thin Dual No Lead (UDFN)

10. Packaging Information

10.1 8S1 — 8-lead JEDEC SOIC

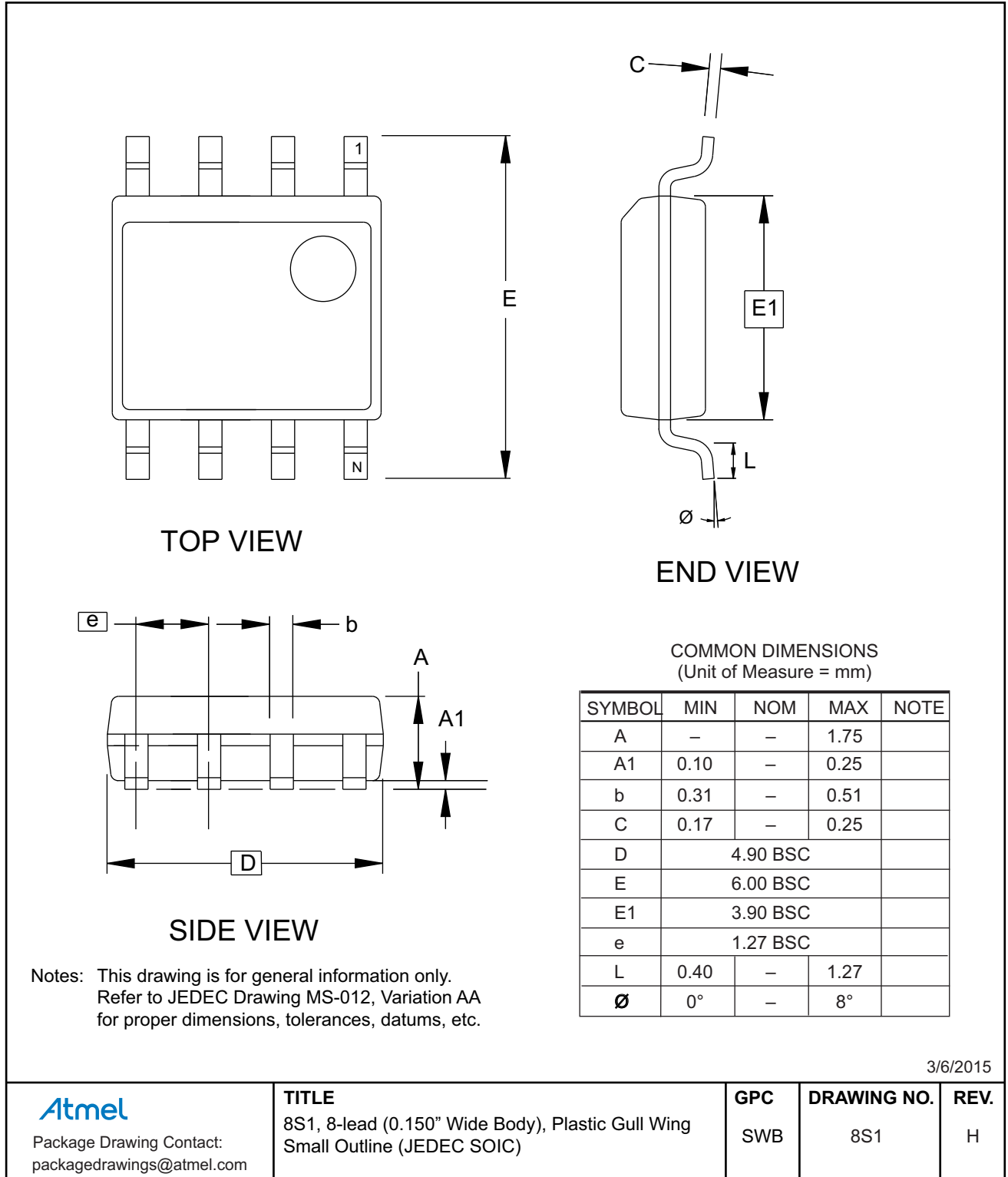

3/6/2015

Atmel

Package Drawing Contact:
packagedrawings@atmel.com

TITLE

8S1, 8-lead (0.150" Wide Body), Plastic Gull Wing
Small Outline (JEDEC SOIC)

GPC

SWB

DRAWING NO.

8S1

REV.

H

10.2 8X — 8-lead TSSOP

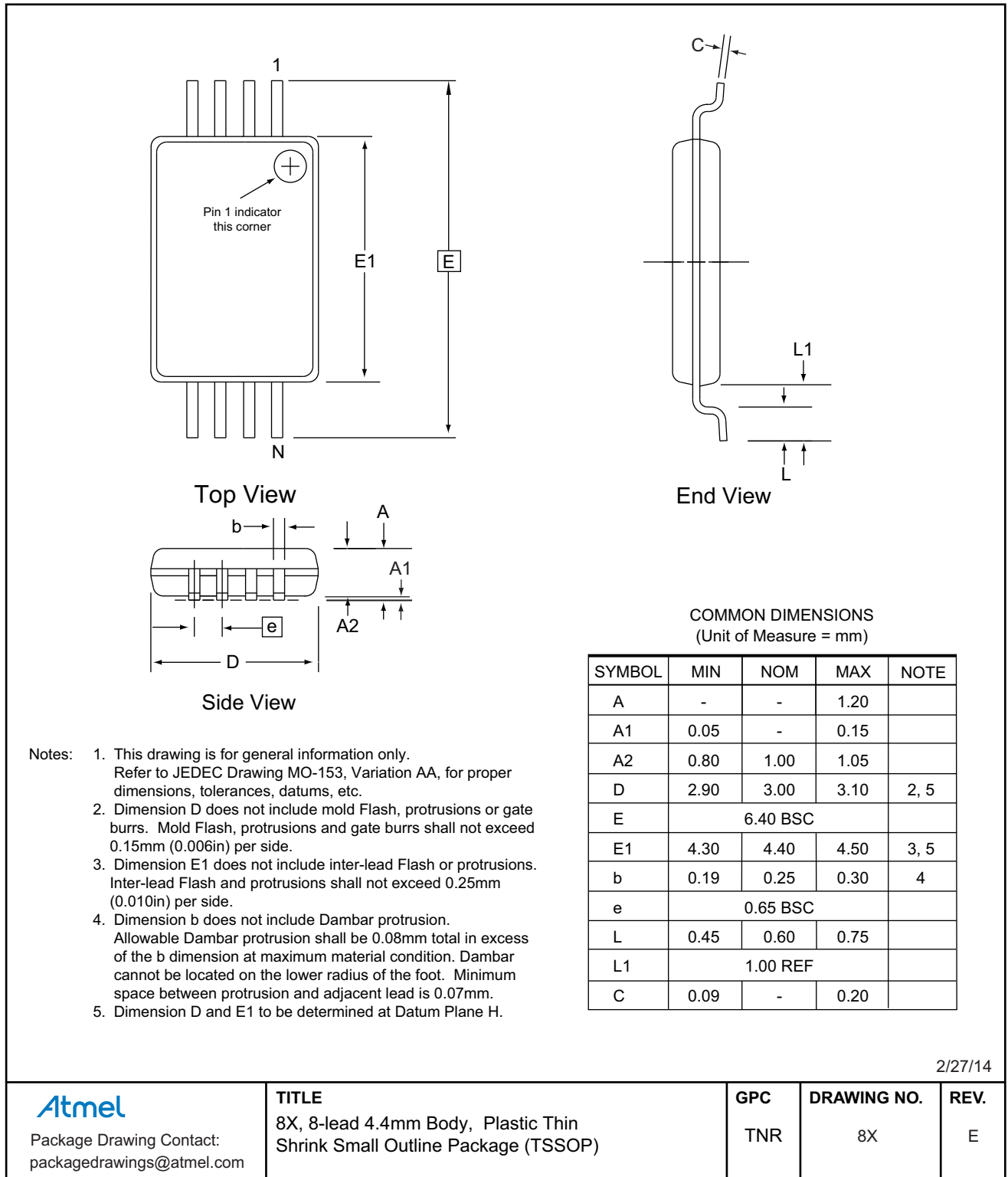

10.3 8MA2 — 8-pad UDFN

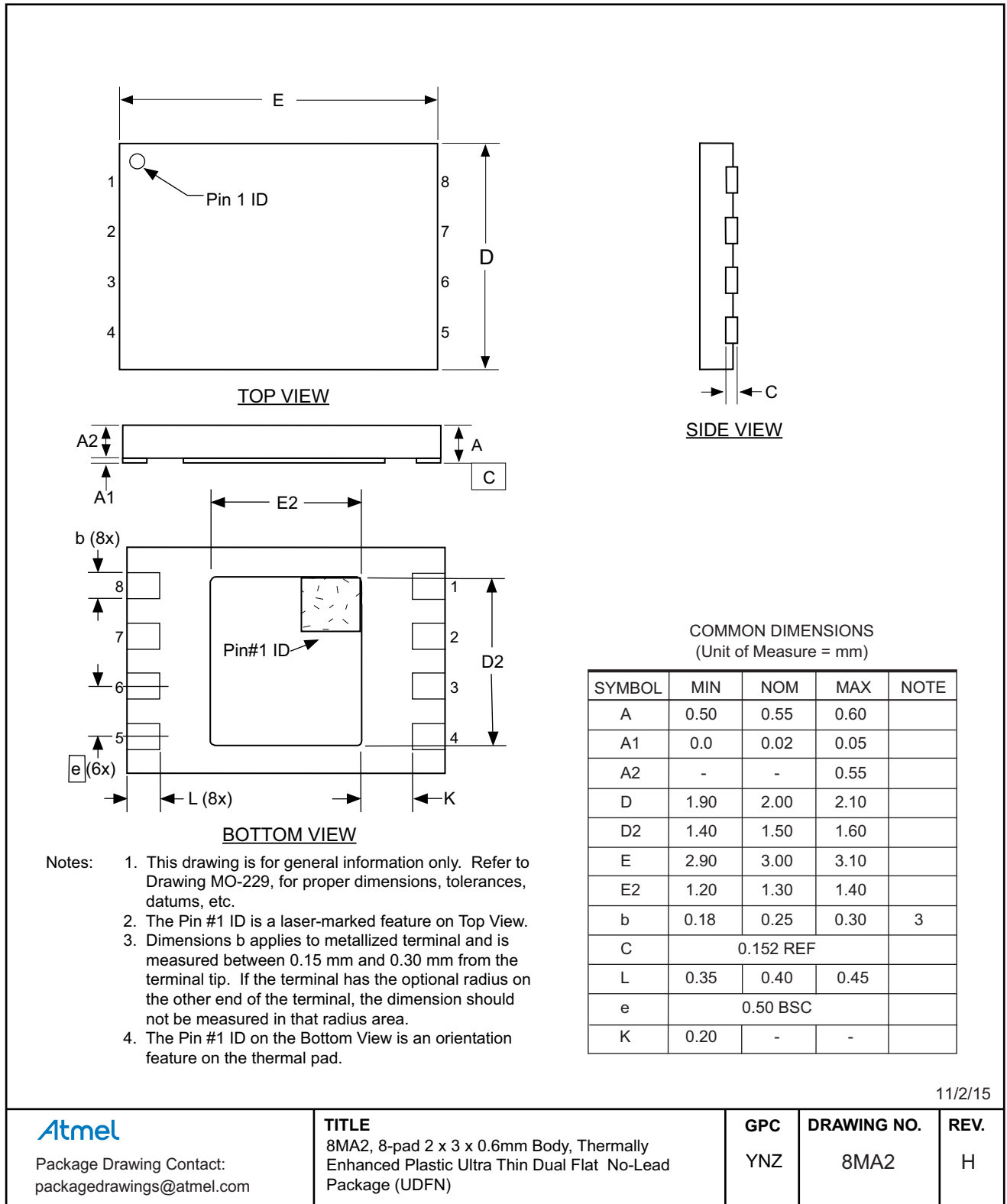

11/2/15

Atmel

Package Drawing Contact:
packagedrawings@atmel.com

TITLE

8MA2, 8-pad 2 x 3 x 0.6mm Body, Thermally Enhanced Plastic Ultra Thin Dual Flat No-Lead Package (UDFN)

GPC

YNZ

DRAWING NO.

8MA2

REV.

H

10.4 8P3 — 8-lead PDIP

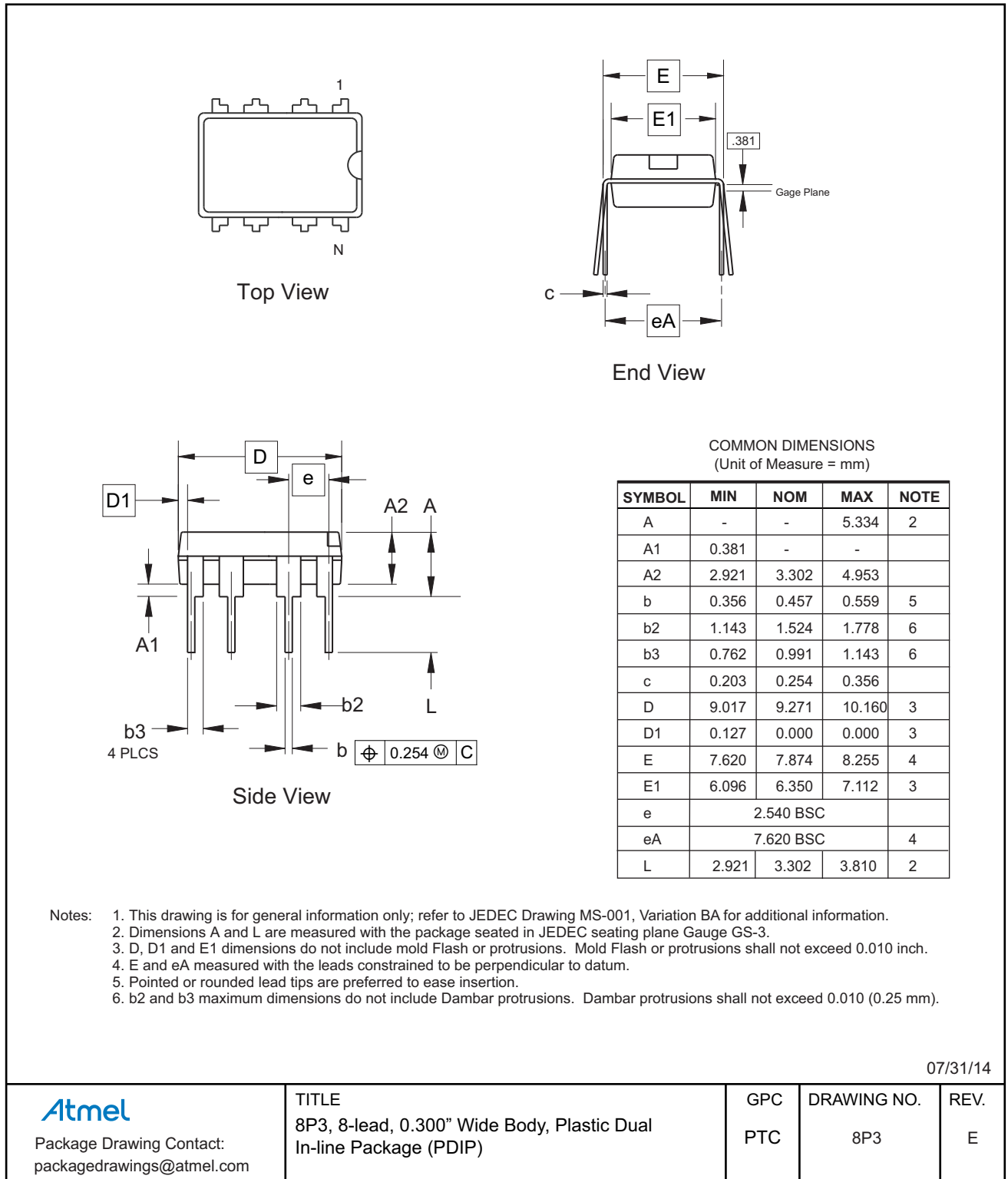

11. Revision History

Revision No.	Date	Comments
3408L	01/2017	Added Bulk (Tube) Shipping Carrier Option Changed Standard Quantity Tape and Reel Option to "T" Updated Ordering Information Table Removed AT93C86A-W1.8-11 Part Number
3408K	12/2015	Correct Ordering Code Detail and update the 8S1 and 8MA2 package drawings.
3408J	01/2015	Add the UDFN extended quantity option and update the ordering information section. Update the 8MA2 and 8P3 package drawings.
3408I	08/2014	Update pinouts, 8MA2 package drawing, grammatical changes, document template, logos, and disclaimer page. No changes to functional specification.
3408H	01/2007	Add "Bottom View" to page 1 Ultra Thin MiniMap package drawing page 4 revise Note 1 added "ensured by characterization".
3408G	07/2006	Revision history implemented. Delete 'Preliminary' status from datasheet; Add 'Ultra Thin' description to MLP 2x3 package; Delete '1.8V not available' on Figure 1 Note; Add 1.8V range on Table 4 under Write Cycle Time.



Atmel Corporation 1600 Technology Drive, San Jose, CA 95110 USA T: (+1)(408) 441.0311 F: (+1)(408) 436.4200 | www.atmel.com

© 2017 Atmel Corporation. / Rev.: Atmel-3408L-SEEPROM-AT93C86A-Datasheet_012017.



Atmel®, Atmel logo and combinations thereof, Enabling Unlimited Possibilities®, and others are registered trademarks or trademarks of Atmel Corporation in U.S. and other countries. Other terms and product names may be trademarks of others.

DISCLAIMER: The information in this document is provided in connection with Atmel products. No license, express or implied, by estoppel or otherwise, to any intellectual property right is granted by this document or in connection with the sale of Atmel products. EXCEPT AS SET FORTH IN THE ATMEL TERMS AND CONDITIONS OF SALES LOCATED ON THE ATMEL WEBSITE, ATMEL ASSUMES NO LIABILITY WHATSOEVER AND DISCLAIMS ANY EXPRESS, IMPLIED OR STATUTORY WARRANTY RELATING TO ITS PRODUCTS INCLUDING, BUT NOT LIMITED TO, THE IMPLIED WARRANTY OF MERCHANTABILITY, FITNESS FOR A PARTICULAR PURPOSE, OR NON-INFRINGEMENT. IN NO EVENT SHALL ATMEL BE LIABLE FOR ANY DIRECT, INDIRECT, CONSEQUENTIAL, PUNITIVE, SPECIAL OR INCIDENTAL DAMAGES (INCLUDING, WITHOUT LIMITATION, DAMAGES FOR LOSS AND PROFITS, BUSINESS INTERRUPTION, OR LOSS OF INFORMATION) ARISING OUT OF THE USE OR INABILITY TO USE THIS DOCUMENT, EVEN IF ATMEL HAS BEEN ADVISED OF THE POSSIBILITY OF SUCH DAMAGES. Atmel makes no representations or warranties with respect to the accuracy or completeness of the contents of this document and reserves the right to make changes to specifications and products descriptions at any time without notice. Atmel does not make any commitment to update the information contained herein. Unless specifically provided otherwise, Atmel products are not suitable for, and shall not be used in, automotive applications. Atmel products are not intended, authorized, or warranted for use as components in applications intended to support or sustain life.







SAFETY-CRITICAL, MILITARY, AND AUTOMOTIVE APPLICATIONS DISCLAIMER: Atmel products are not designed for and will not be used in connection with any applications where the failure of such products would reasonably be expected to result in significant personal injury or death ("Safety-Critical Applications") without an Atmel officer's specific written consent. Safety-Critical Applications include, without limitation, life support devices and systems, equipment or systems for the operation of nuclear facilities and weapons systems. Atmel products are not designed nor intended for use in military or aerospace applications or environments unless specifically designated by Atmel as military-grade. Atmel products are not designed nor intended for use in automotive applications unless specifically designated by Atmel as automotive-grade.

Looking for pricing, stock, or lifecycle information?

Click below to explore more details on WIN SOURCE:

-  [View AT93C86A-10SU-1.8 on WIN SOURCE](#)
-  [Atmel Information](#)

Optimize Your Supply Chain with WIN SOURCE Solutions

-  Global Sourcing Solution
-  Obsolete Management
-  Cost Control Management
-  Shortage Management
-  Alternative Solution
-  Excess Inventory Management