



**THE DATASHEET OF  
97-3106A-12S-3S(946)**



4

3

2

1

REVISIONS				
ZONE	LTR	DESCRIPTION	DATE	APPROVED
	C	(CLII) ADDED NOTE 7 ECN: 22391	08/29/89 BURNSIDE	J.B. m.n.
	D	(CL II) RELOC STAMPING NOTE ECN: 26372	7/17/91 PRESCOTT	em
	E	(CLII) CHANGE BLOCK CHANGE ONLY WAS SHELL 10-617702-XX3 (NO SLOT) ECN: 90058	11-17-04 DEMATTEO	J.C.
	F	(CL II) SEE CHANGE NOTICE ECN: A5986	4-20-09	H.BROOKER

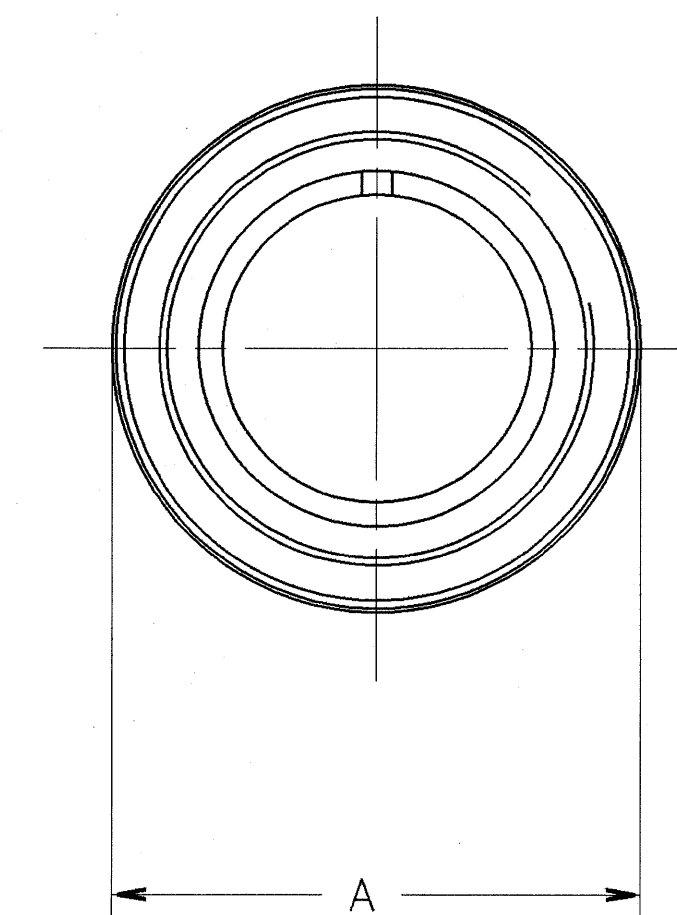
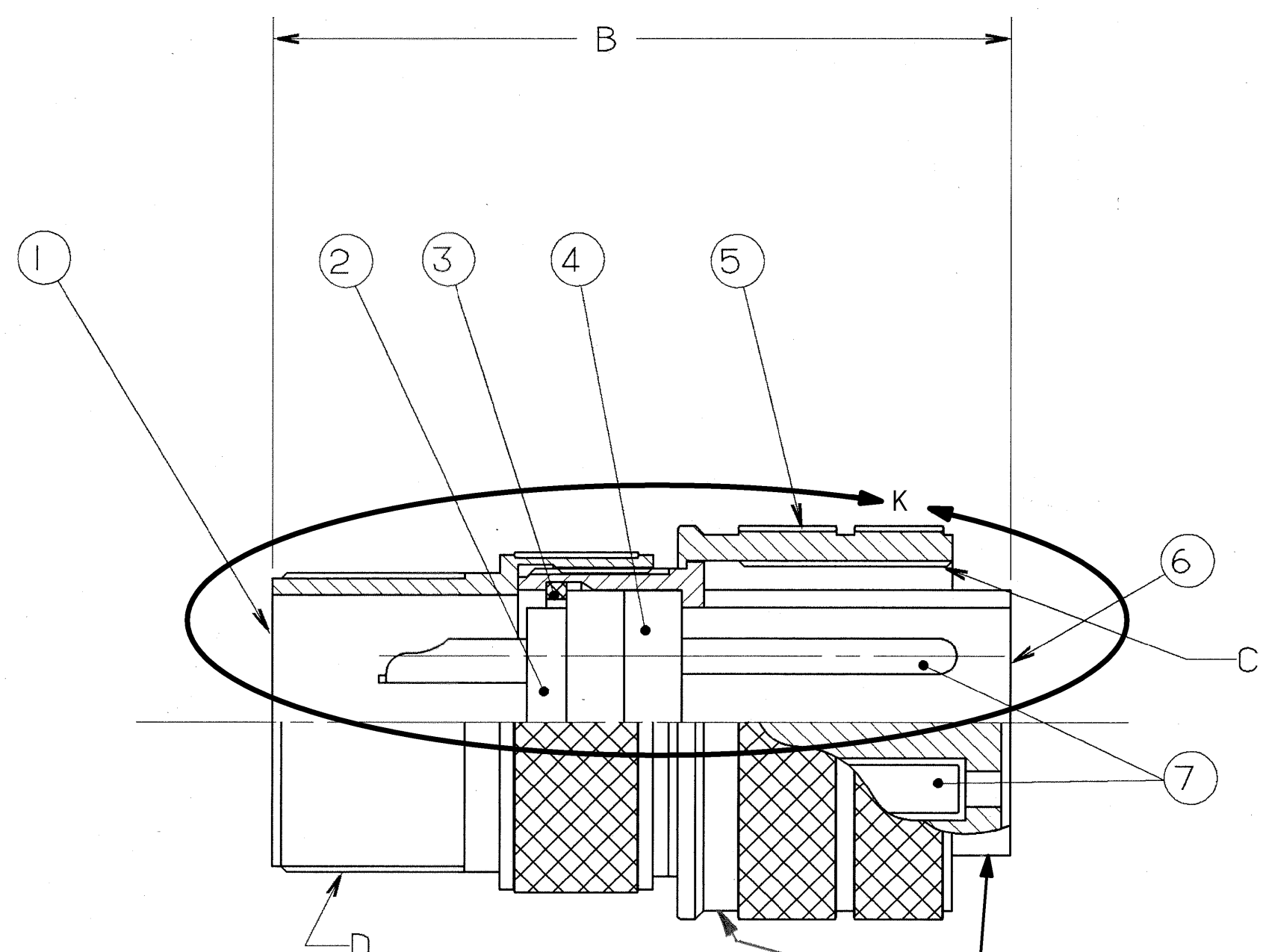

STAMP MS OR AMPHENOL ASSEMBLY NUMBER ON THIS SURFACE. CHARACTER HEIGHT .062 MINIMUM.

SEE SHEET 2.  
NOTES:

THE USE OF THIS DOCUMENT IS UNLIMITED. HOWEVER, DOCUMENTS REFERENCED HEREON MAY CONTAIN LIMITED RIGHTS DATA.

N/A  
N/A  
NEXT ASSEMBLY

UNLESS OTHERWISE SPECIFIED LINEAR DIMENSIONS ARE IN INCHES.  
TOLERANCES: .XXX±.010,  
.XX ±.03, .X ±.1,  
ANGLES ±2°.  
OTHER STANDARDS PER 9-3800 AND DOD-D-1000.  
NOTE REF. =

FIND NO.	QTY REQD.	FSCM NO.	PART NUMBER	DESCRIPTION	NOTE REF.
9	1		10-825966-062	RING RETAINING, CPL (12SL ONLY)	
8	1		10-824853-014	RING RETAINING, CPL (10SL ONLY)	
7	SEE NOTE		SEE NOTE 1	CONTACTS	
6				SHELL	
5				RING, COUPLING	
4				INSERT, FRONT	
3				RING RETAINER	
2				INSERT, REAR	
1				BACK SHELL	

PARTS LIST					
SPECIFICATIONS	SIGNATURES	DATES	AMPHENOL CORPORATION BENDIX CONNECTOR OPERATIONS SIDNEY, N.Y.		
MATERIAL SPEC. N/A	PREPARED A. PRESCOTT CHECKED PHILPOTT MATERIAL	11/6/87 11/09/87	CONNECTOR, ELECTRICAL PLUG, TYPE 97-3106A, OLIVE DRAB CADMIUM PLATED		
PROCESS SPEC. 9-2437-33	APPROVED BERNHARDT APPROVED HAYNER 1ST PART NO.	11/10/87 11/10/87	SIZE C	FSCM NO. 77820	REV. F
	SF-820071-06P		SCALE NONE	WT. REF N/A	SHEET 1 OF 2

97-3106A

4

3

2

1

BENDIX ASSEMBLY NUMBER	AMPHENOL ASSEMBLY NUMBER	MS ASSEMBLY NUMBER	A DIA.	B	C THREAD	D THREAD
10-820060-()	97-3106A- 8S -()	MS 3106A- 8S -()	.750	1.250	.5000-28 UNEF-2B	.5000-28 UNEF-2A
10-820061-()	-10S -()	-10S -()	.875	1.312	.6250-24 UNEF-2B	.5000-28 UNEF-2A
10-820062-()	-10SL-()	-10SL-()	.875	1.375	.6250-24 UNEF-2B	.6250-24 UNEF-2A
10-820063-()	-12S -()	-12S -()	1.000	1.438	.7500-20 UNEF-2B	.6250-24 UNEF-2A
10-820064-()	-12SL-()	-12SL-()	1.000	1.484	.7500-20 UNEF-2B	.7500-20 UNEF-2A
10-820065-()	-12 -()	-12 -()	1.000	1.875	.7500-20 UNEF-2B	.6250-24 UNEF-2A
10-820066-()	-14S -()	-14S -()	1.125	1.438	.8750-20 UNEF-2B	.7500-20 UNEF-2A
10-820067-()	-14 -()	-14 -()	1.125	1.875	.8750-20 UNEF-2B	.7500-20 UNEF-2A
10-820068-()	-16S -()	-16S -()	1.250	1.453	1.0000-20 UNEF-2B	.8750-20 UNEF-2A
10-820069-()	-16 -()	-16 -()	1.250	1.891	1.0000-20 UNEF-2B	.8750-20 UNEF-2A
10-820070-()	-18 -()	-18 -()	1.344	2.000	1.1250-18 UNEF-2B	1.0000-20 UNEF-2A
10-820071-()	-20 -()	-20 -()	1.469	2.125	1.2500-18 UNEF-2B	1.1875-18 UNEF-2A
10-820072-()	-22 -()	-22 -()	1.594	2.125	1.3750-18 UNEF-2B	1.1875-18 UNEF-2A
10-820073-()	-24 -()	-24 -()	1.719	2.250	1.5000-18 UNEF-2B	1.4375-18 UNEF-2A
10-820074-()	-28 -()	-28 -()	1.969	2.250	1.7500-18 UNEF-2B	1.4375-18 UNEF-2A
10-820075-()	-32 -()	-32 -()	2.219	2.375	2.0000-18 UNEF-2B	1.7500-18 UNEF-2A
10-820076-()	-36 -()	-36 -()	2.469	2.375	2.2500-16 UN-2B	2.0000-18 UNEF-2A
10-820077-()	-40 -()	-40 -()	2.719	2.375	2.5000-16 UN-2B	2.2500-16 UN-2A
10-820078-()	-44 -()	-44 -()	NOT AVAILABLE			
10-820079-()	-48 -()	-48 -()	NOT AVAILABLE			

TO COMPLETE, ADD APPLICABLE INSERT ARRANGEMENT SUFFIX PER 9-2437-33.

6

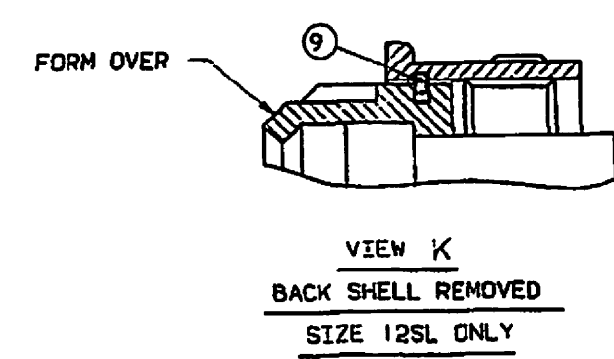
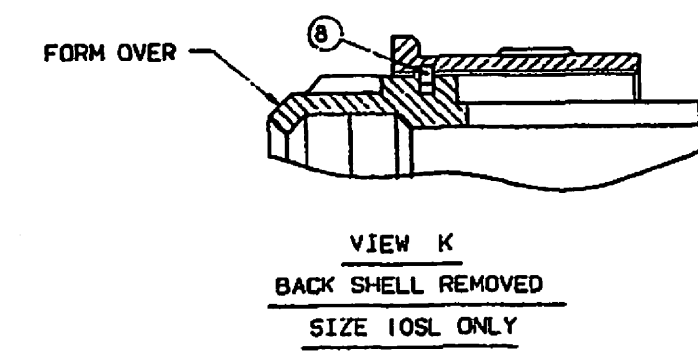

7. IDENTIFY PACKAGE WITH APPLICABLE MS OR 97- PART NUMBER PER NOTE 6.
6. FOR BENDIX INSERT ARRANGEMENT SUFFIX -1 THROUGH -49, STAMP MS ASSEMBLY NUMBER. FOR BENDIX INSERT ARRANGEMENT SUFFIX -50 THROUGH -99, AND -AA THROUGH -BC, STAMP AMPHENOL ASSEMBLY NUMBER.
5. FOR CONTACT ARRANGEMENT, SEE MIL-STD-1651 AND L-22208-() THROUGH L-22248-().
4. PACKAGE PER PRODUCTION PROCESS SHEET.
3. UNITS MEET THE APPLICABLE REQUIREMENTS OF MIL-C-5015.
2. SEE WORK ORDER FOR PERMISSIBLE ADDITIONAL OR ALTERNATE STAMPING.
1. SEE SEPARATE PARTS LIST FOR COMPONENT PART NUMBERS AND QUANTITIES.

NOTES:

THE USE OF THIS DOCUMENT IS UNLIMITED. HOWEVER, DOCUMENTS REFERENCED HEREON MAY CONTAIN LIMITED RIGHTS DATA.

SIZE	FSCM NO.	REV.
C	77820	F
SCALE	WT.	REF.
		SHEET 2

97-3106A

B

A

D

D

C

C

B

A

## Looking for pricing, stock, or lifecycle information?

Click below to explore more details on WIN SOURCE:

- [View 97-3106A-12S-3S\(946\) on WIN SOURCE](#)
- [Amphenol Industrial Operations Information](#)

## Optimize Your Supply Chain with WIN SOURCE Solutions

- ✓ Global Sourcing Solution
- ✓ Obsolete Management
- ✓ Cost Control Management
- ✓ Shortage Management
- ✓ Alternative Solution
- ✓ Excess Inventory Management