



THE DATASHEET OF
932SQ428AKLF



General Description

The 932SQ428 is a main clock synthesizer for Romley-generation Intel based server platforms. The 932SQ428 is driven with a 25 MHz crystal for maximum performance. It generates CPU outputs of 100MHz.

Recommended Application

CK420BQ

Output Features

- 2 - HCSL Non-Spread SAS outputs
- 3 - HCSL SRC outputs - can be used as CPU@100M
- 1 - HCSL DOT96 output
- 1 - 3.3V 48M output
- 5 - 3.3V PCI outputs
- 1 - 3.3V 14.318M output

Features/Benefits

- 0.5% down spread capable on SRC/PCI outputs; Lower EMI
- 48-pin MLF package; Space Savings

Key Specifications

- Cycle to cycle jitter: SRC/NS_SAS < 50ps
- Phase jitter: PCIe Gen2 < 3ps rms
- Phase jitter: PCIe Gen3 < 1ps rms
- Phase jitter: QPI 9.6GB/s < 0.2ps rms
- Phase jitter: NS-SAS < 0.4ps rms using raw phase data
- Phase jitter: NS-SAS < 1.3ps rms using Clk Jit Tool 1.6.3

Block Diagram

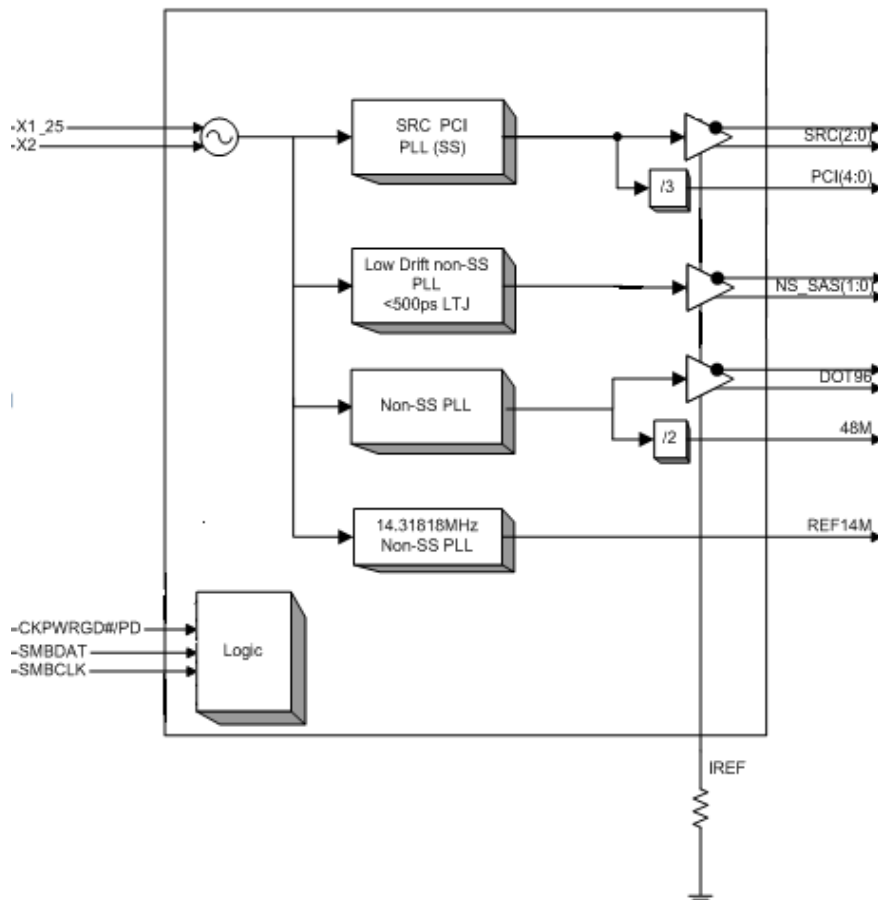

Pin Configuration

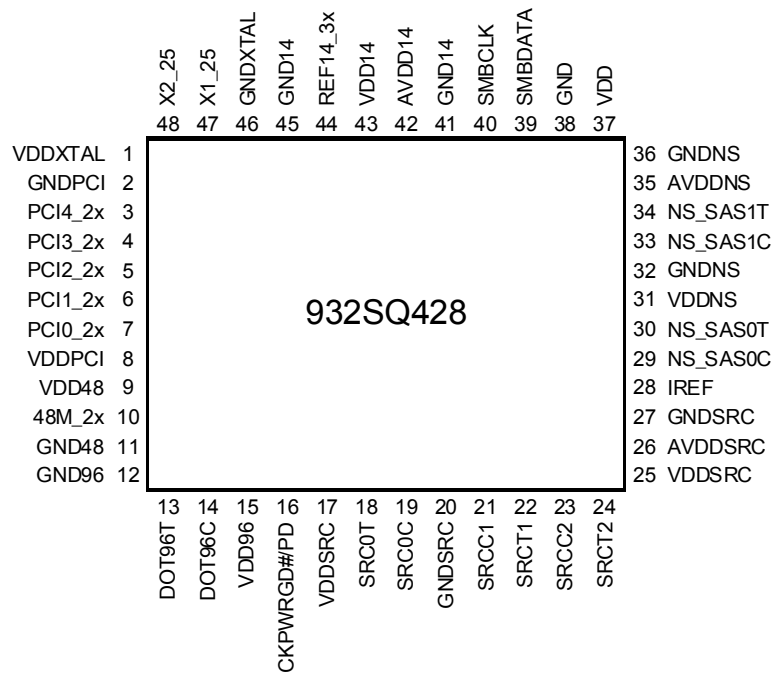

48-Pin MLF (6x6mm 0.4mm pitch)

Pins with ^ prefix have internal 120K pullup
Pins with v prefix have internal 120K pulldown

932SQ428 Functionality

SRC	PCI	REF	NS_SAS	DOT96	USB	Unit
100	33.33	14.318	100.00	96.00	48.00	MHz

Spread Spectrum Control

SS_Enable (B1b0)	SRC & PCI
0	OFF
1	ON

Power Group Table

MLF		Description
VDD	GND	
42	41	14MHz PLL Analog
43	45	REF14M Output and Logic
1	46	25MHz XTAL
8	2	PCI Outputs and Logic
9	11	48MHz Output and Logic
15	12	96MHz PLL Analog, Output and Logic
17, 25	20	SRC Outputs and Logic
26	27	SRC PLL Analog
31	32	Non-Spreading Differential Outputs & Logic
35	36	NS-SAS PLL Analog
37	38	Core Logic

932SQ428 Power Down Functionality

CKPWRGD#/PD	Differential Outputs	Single-ended Outputs	Single ended Outputs w/Latch
1	HI-Z ¹	Low	Low ²
0	Running		

1. Hi-Z on the differential outputs will result in both True and Complement being low due to the termination network
2. These outputs are Hi-Z after VDD is applied and before the first assertion of CKPWRGD#.

Pin Descriptions

PIN #	PIN NAME	TYPE	DESCRIPTION
1	VDDXTAL	PWR	3.3V power for the crystal oscillator.
2	GNDPCI	PWR	Ground pin for PCI outputs and logic.
3	PCI4_2x	OUT	3.3V PCI clock output
4	PCI3_2x	OUT	3.3V PCI clock output
5	PCI2_2x	OUT	3.3V PCI clock output
6	PCI1_2x	OUT	3.3V PCI clock output
7	PCI0_2x	OUT	3.3V PCI clock output
8	VDDPCI	PWR	3.3V power for the PCI outputs and logic
9	VDD48	PWR	3.3V power for the 48MHz output and logic
10	48M_2x	OUT	3.3V 48MHz output
11	GND48	PWR	Ground pin for 48MHz output and logic.
12	GND96	PWR	Ground pin for DOT96 output and logic.
13	DOT96T	OUT	True clock of differential 96MHz output. These are current mode outputs. These are current mode outputs and external 33 ohm series resistors and 49.9 ohm shunt resistors are required for termination.
14	DOT96C	OUT	Complementary clock of differential 96MHz output. These are current mode outputs and external 33 ohm series resistors and 49.9 ohm shunt resistors are required for termination.
15	VDD96	PWR	3.3V power for the 48/96MHz PLL and the 96MHz output and logic
16	CKPWRGD#/PD	IN	CKPWRGD# is an active low input used to sample latched inputs and allow the device to Power Up. PD is an asynchronous active high input pin used to put the device into a low power state. The internal clocks and PLLs are stopped.
17	VDDSRC	PWR	3.3V power for the SRC outputs and logic
18	SRC0T	OUT	True clock of differential SRC output. These are current mode outputs. These are current mode outputs and external 33 ohm series resistors and 49.9 ohm shunt resistors are required for termination.
19	SRC0C	OUT	Complementary clock of differential SRC output. These are current mode outputs and external 33 ohm series resistors and 49.9 ohm shunt resistors are required for termination.
20	GNDSRC	PWR	Ground pin for SRC outputs and logic.
21	SRCC1	OUT	Complementary clock of differential SRC output. These are current mode outputs and external 33 ohm series resistors and 49.9 ohm shunt resistors are required for termination.
22	SRCT1	OUT	True clock of differential SRC output. These are current mode outputs. These are current mode outputs and external 33 ohm series resistors and 49.9 ohm shunt resistors are required for termination.
23	SRCC2	OUT	Complementary clock of differential SRC output. These are current mode outputs and external 33 ohm series resistors and 49.9 ohm shunt resistors are required for termination.
24	SRCT2	OUT	True clock of differential SRC output. These are current mode outputs. These are current mode outputs and external 33 ohm series resistors and 49.9 ohm shunt resistors are required for termination.
25	VDDSRC	PWR	3.3V power for the SRC outputs and logic
26	AVDDSRC	PWR	3.3V power for the SRC PLL analog circuits
27	GNDSRC	PWR	Ground pin for SRC outputs and logic.
28	IREF	OUT	This pin establishes the reference current for the differential current-mode output pairs. This pin requires a fixed precision resistor tied to ground in order to establish the appropriate current. 475 ohms is the standard value.
29	NS_SAS0C	OUT	Complementary clock of differential non-spreading SAS output. These are current mode outputs and external 33 ohm series resistors and 49.9 ohm shunt resistors are required for termination.
30	NS_SAS0T	OUT	True clock of differential non-spreading SAS output. These are current mode outputs. These are current mode outputs and external 33 ohm series resistors and 49.9 ohm shunt resistors are required for termination.
31	VDDNS	PWR	3.3V power for the Non-Spreading differential outputs outputs and logic
32	GNDNS	PWR	Ground pin for non-spreading differential outputs and logic.
33	NS_SAS1C	OUT	Complementary clock of differential non-spreading SAS output. These are current mode outputs and external 33 ohm series resistors and 49.9 ohm shunt resistors are required for termination.
34	NS_SAS1T	OUT	True clock of differential non-spreading SAS output. These are current mode outputs. These are current mode outputs and external 33 ohm series resistors and 49.9 ohm shunt resistors are required for termination.

Pin Descriptions (cont.)

35	AVDDNS	PWR	3.3V power for the non-spreading SAS PLL analog circuits.
36	GNDNS	PWR	Ground pin for non-spreading differential outputs and logic.
37	VDD	PWR	3.3V power for core logic
38	GND	PWR	Ground pin for core logic.
39	SMBDATA	I/O	Data pin of SMBUS circuitry, 5V tolerant
40	SMBCLK	IN	Clock pin of SMBUS circuitry, 5V tolerant
41	GND14	PWR	Ground pin for 14MHz output and logic.
42	AVDD14	PWR	Analog power pin for 14MHz PLL
43	VDD14	PWR	Power pin for 14MHz output and logic, nominal 3.3V
44	REF14_3x	OUT	14.318 MHz reference clock. 3X drive strength as default
45	GND14	PWR	Ground pin for 14MHz output and logic.
46	GNDXTAL	PWR	Ground pin for Crystal Oscillator.
47	X1_25	IN	Crystal input, Nominally 25.00MHz.
48	X2_25	OUT	Crystal output, Nominally 25.00MHz.

Test Loads and Recommended Terminations

932SQ428 Differential Test Loads

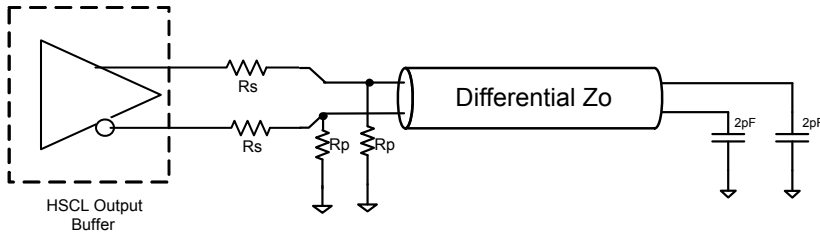

Differential Output Termination Table

DIF Zo (Ω)	Iref (Ω)	Rs (Ω)	Rp (Ω)
100	475	33	50
85	412	27	42.2 or 43.2

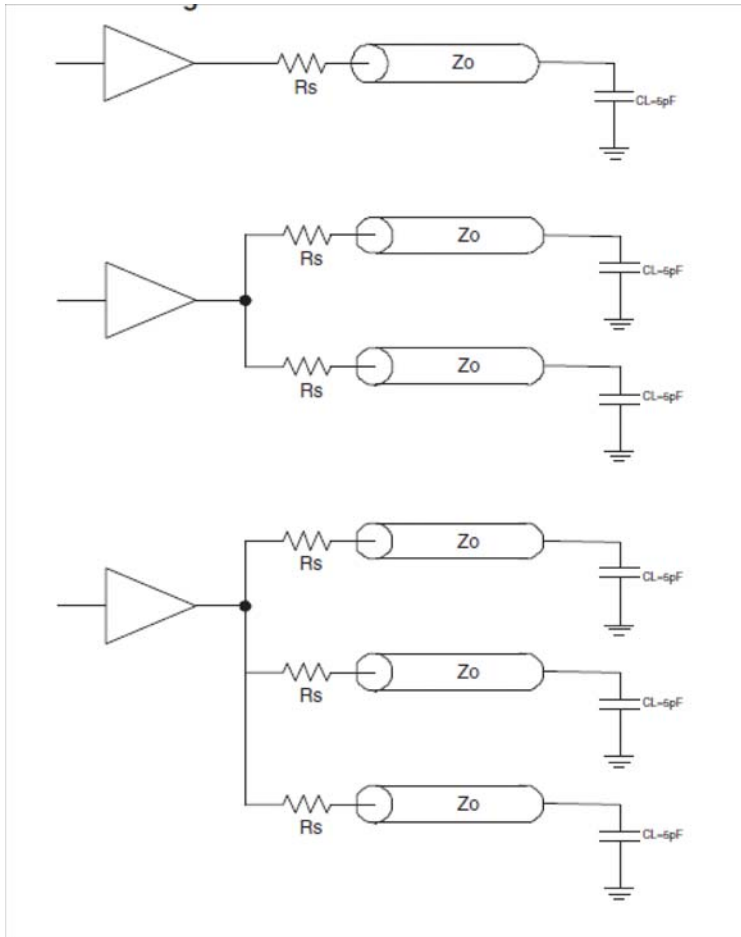

Single-ended Output Termination Table

Output	Loads	Rs Value (for each load)	
		Zo = 50 Ω	Zo = 60 Ω
PCI/USB	1	36	43
PCI/USB	2	22	33
REF	1	39	47
REF	2	27	36
REF	3	10	20

Electrical Characteristics - Absolute Maximum Ratings

PARAMETER	SYMBOL	CONDITIONS	MIN	TYP	MAX	UNITS	NOTES
3.3V Core Supply Voltage	VDDA				4.6	V	1,2
3.3V Logic Supply Voltage	VDD				4.6	V	1,2
Input Low Voltage	V _{IL}		GND-0.5			V	1
Input High Voltage	V _{IH}	Except for SMBus interface			V _{DD} +0.5V	V	1
Input High Voltage	V _{IHSMB}	SMBus clock and data pins			5.5V	V	1
Storage Temperature	T _s		-65		150	°C	1
Junction Temperature	T _j				125	°C	1
Input ESD protection	ESD prot	Human Body Model	2000			V	1

¹Guaranteed by design and characterization, not 100% tested in production.

²Operation under these conditions is neither implied nor guaranteed.

Electrical Characteristics - Current Consumption

T_A = T_{COM}; Supply Voltage VDD = 3.3 V +/-5%

PARAMETER	SYMBOL	CONDITIONS	MIN	TYP	MAX	UNITS	NOTES
Operating Supply Current	I _{DD3.30P}	All outputs active @100MHz, C _L = Full load;		250	300	mA	1
Powerdown Current	I _{DD3.3PDZ}	All differential pairs tri-stated		12	20	mA	1

¹Guaranteed by design and characterization, not 100% tested in production.

DC Electrical Characteristics - Differential Current Mode Outputs

T_A = T_{COM}; Supply Voltage VDD = 3.3 V +/-5%

PARAMETER	SYMBOL	CONDITIONS	MIN	TYP	MAX	UNITS	NOTES
Slew rate	Trf	Scope averaging on	1	2.4	4	V/ns	1, 2, 3
Slew rate matching	ΔTrf	Slew rate matching, Scope averaging on		9	20	%	1, 2, 4
Rise/Fall Time Variation	ΔTrf	Rise/fall variation, Scope averaging off		18	125	ps	1, 7, 8
Voltage High	VHigh	Statistical measurement on single-ended signal using	660	772	850	mV	1
Voltage Low	VLow		-150	9	150		1
Max Voltage	Vmax	Measurement on single ended signal using absolute value.		810	1150	mV	1, 7
Min Voltage	Vmin		-300	-17			1, 7
Vswing	Vswing	Scope averaging off	300	1446		mV	1, 2
Crossing Voltage (abs)	Vcross_abs	Scope averaging off	250	351	550	mV	1, 5
Crossing Voltage (var)	Δ-Vcross	Scope averaging off		24	140	mV	1, 6

¹Guaranteed by design and characterization, not 100% tested in production. I_{REF} = VDD/(3xR_R). For R_R = 475Ω (1%), I_{REF} = 2.32mA. I_{OH} = 6 x I_{REF} and V_{OH} = 0.7V @ Z_O=50Ω (100Ω differential impedance).

² Measured from differential waveform

³ Slew rate is measured through the Vswing voltage range centered around differential 0V. This results in a +/-150mV window around differential 0V.

⁴ Matching applies to rising edge rate for Clock and falling edge rate for Clock#. It is measured using a +/-75mV window centered on the average cross point where Clock rising meets Clock# falling. The median cross point is used to calculate the voltage thresholds the oscilloscope is to use for the edge rate calculations.

⁵ Vcross is defined as voltage where Clock = Clock# measured on a component test board and only applies to the differential rising edge (i.e. Clock rising and Clock# falling).

⁶ The total variation of all Vcross measurements in any particular system. Note that this is a subset of V_cross_min/max (V_cross absolute) allowed. The intent is to limit Vcross induced modulation by setting V_cross_delta to be smaller than V_cross absolute.

⁷ Includes overshoot and undershoot.

Electrical Characteristics - Input/Supply/Common Parameters

TA = T_{COM}; Supply Voltage VDD = 3.3 V +/-5%

PARAMETER	SYMBOL	CONDITIONS	MIN	TYP	MAX	UNITS	NOTES
Ambient Operating Temperature	T _{COM}	Commercial range	0		70	°C	1
Input High Voltage	V _{IH}	Single-ended inputs, except SMBus, low threshold and tri-level inputs	2		V _{DD} + 0.3	V	1
Input Low Voltage	V _{IL}	Single-ended inputs, except SMBus, low threshold and tri-level inputs	GND - 0.3		0.8	V	1
Input Current	I _{IN}	Single-ended inputs, V _{IN} = GND, V _{IN} = VDD	-5		5	uA	1
	I _{INP}	Single-ended inputs. V _{IN} = 0 V; Inputs with internal pull up resistors V _{IN} = VDD; Inputs with internal pull-down resistors	-200		200	uA	1
Low Threshold Input-High Voltage	V _{IH_FS}	3.3 V +/-5%	0.7		V _{DD} + 0.3	V	1
Low Threshold Input-Low Voltage	V _{IL_FS}	3.3 V +/-5%	V _{SS} - 0.3		0.35	V	1
Input Frequency	F _i			25.00		MHz	2
Pin Inductance	L _{p.in}				7	nH	1
Capacitance	C _{IN}	Logic Inputs			5	pF	1
	C _{OUT}	Output pin capacitance			5	pF	1
	C _{INX}	X1 & X2 pins			5	pF	1
Clk Stabilization	T _{STAB}	From V _{DD} Power-Up and after input clock stabilization or de-assertion of PD# to 1st clock			1.8	ms	1,2
SS Modulation Frequency	f _{MODIN}	Allowable Frequency (Triangular Modulation)	30	31.500	33	kHz	1
Tdrive_PD#	t _{DRVPD}	Differential output enable after PD# de-assertion		200.000	300	us	1,3
Tfall	t _F	Fall time of control inputs			5	ns	1,2
Trise	t _R	Rise time of control inputs			5	ns	1,2
SMBus Input Low Voltage	V _{ILSMB}				0.8	V	1
SMBus Input High Voltage	V _{IHSMB}		2.1		V _{DDSMB}	V	1
SMBus Output Low Voltage	V _{OLSMB}	@ I _{PULLUP}			0.4	V	1
SMBus Sink Current	I _{PULLUP}	@ V _{OL}	4			mA	1
Nominal Bus Voltage	V _{DDSMB}	3V to 5V +/- 10%	2.7		5.5	V	1
SCLK/SDATA Rise Time	t _{RSMB}	(Max VIL - 0.15) to (Min VIH + 0.15)			1000	ns	1
SCLK/SDATA Fall Time	t _{FSMB}	(Min VIH + 0.15) to (Max VIL - 0.15)			300	ns	1
SMBus Operating Frequency	f _{MAXSMB}	Maximum SMBus operating frequency			100	kHz	1

¹Guaranteed by design and characterization, not 100% tested in production.

²Control input must be monotonic from 20% to 80% of input swing.

³Time from deassertion until outputs are >200 mV

AC Electrical Characteristics - Differential Current Mode Outputs

$T_A = T_{COM}$; Supply Voltage $V_{DD} = 3.3\text{ V} \pm 5\%$

PARAMETER	SYMBOL	CONDITIONS	MIN	TYP	MAX	UNITS	NOTES
Duty Cycle	t_{DC}	Measured differentially, PLL Mode	45	50.1	55	%	1
Skew, Output to Output	t_{sk3SRC}	Across all SRC outputs, $V_T = 50\%$		13.5	50	ps	1
Jitter, Cycle to cycle	$t_{jyc-cyc}$	SRC, NS_SAS outputs		35	50	ps	1,3
		DOT96 output		75	250	ps	1,3

¹ Guaranteed by design and characterization, not 100% tested in production.

² $I_{REF} = V_{DD}/(3 \times R_R)$. For $R_R = 475\Omega$ (1%), $I_{REF} = 2.32\text{mA}$. $I_{OH} = 6 \times I_{REF}$ and $V_{OH} = 0.7\text{V}$ @ $Z_O = 50\Omega$.

³ Measured from differential waveform

Electrical Characteristics - Phase Jitter Parameters

$T_A = 0 - 70^\circ\text{C}$; Supply Voltage $V_{DD}/V_{DDA} = 3.3\text{ V} \pm 5\%$,

PARAMETER	SYMBOL	CONDITIONS	MIN	TYP	MAX	UNITS	Notes
Phase Jitter	$t_{jphPCleG1}$	PCIe Gen 1		28	86	ps (p-p)	1,2,3,6
	$t_{jphPCleG2}$	PCIe Gen 2 Lo Band 10kHz < f < 1.5MHz		0.9	3	ps (rms)	1,2,6
		PCIe Gen 2 High Band 1.5MHz < f < Nyquist (50MHz)		1.7	3.1	ps (rms)	1,2,6
	$t_{jphPCleG3}$	PCIe Gen 3 (PLL BW of 2-4MHz, CDR = 10MHz)		0.4	1	ps (rms)	1,2,4,6
	t_{jphQPI_SMI}	QPI & SMI (100MHz or 133MHz, 4.8Gb/s, 6.4Gb/s 12UI)		0.15	0.5	ps (rms)	1,5,6
		QPI & SMI (100MHz, 8.0Gb/s, 12UI)		0.13	0.3	ps (rms)	1,5,6
		QPI & SMI (100MHz, 9.6Gb/s, 12UI)		0.11	0.2	ps (rms)	1,5,6
	$t_{jphSAS12G}$	SAS12G (Filtered REFCLK Jitter 20KHz to 20MHz.)		0.34	0.4	ps (rms)	1,7,8
$t_{jphSAS12G}$	SAS 12G		0.70	1.3	ps (rms)	1,5,7	

¹ Guaranteed by design and characterization, not 100% tested in production.

² See <http://www.pcisig.com> for complete specs

³ Sample size of at least 100K cycles. This figures extrapolates to 108ps pk-pk @ 1M cycles for a BER of 1-12.

⁴ Subject to final radification by PCI SIG.

⁵ Calculated from Intel-supplied Clock Jitter Tool v 1.6.6

⁶ Applies to SRC outputs

⁷ Applies to NS_SAS, NS_SRC outputs, Spread Off

⁸ Intel calculation from raw phase noise data

Electrical Characteristics - PCI

$T_A = 0 - 70^\circ\text{C}$; Supply Voltage $V_{DD}/V_{DDA} = 3.3\text{ V} \pm 5\%$,

PARAMETER	SYMBOL	CONDITIONS	MIN	TYP	MAX	UNITS	NOTES
Output Impedance	R_{DSP}	$V_O = V_{DD}^*(0.5)$	12		55	Ω	1
Output High Voltage	V_{OH}	$I_{OH} = -1\text{ mA}$	2.4			V	1
Output Low Voltage	V_{OL}	$I_{OL} = 1\text{ mA}$			0.55	V	1
Output High Current	I_{OH}	MIN @ $V_{OH} = 1.0\text{ V}$	-33			mA	1
		MAX @ $V_{OH} = 3.135\text{ V}$			-33	mA	1
Output Low Current	I_{OL}	MIN @ $V_{OL} = 1.95\text{ V}$	30			mA	1
		MAX @ $V_{OL} = 0.4\text{ V}$			38	mA	1
Clock High Time	T_{HIGH}	1.5V	12			ns	1
Clock Low Time	T_{LOW}	1.5V	12			ns	1
Edge Rate	$t_{slew/f}$	Rising/Falling edge rate	1	1.8	4	V/ns	1,2
Duty Cycle	d_{t1}	$V_T = 1.5\text{ V}$	45	50.5	55	%	1
Group Skew	t_{skew}	$V_T = 1.5\text{ V}$		294	500	ps	1
Jitter, Cycle to cycle	$t_{jcy-cyc}$	$V_T = 1.5\text{ V}$		108	500	ps	1

See "Single-ended Test Loads Page" for termination circuits

¹Guaranteed by design and characterization, not 100% tested in production.

²Measured between 0.8V and 2.0V

Electrical Characteristics - 48MHz

$T_A = 0 - 70^\circ\text{C}$; Supply Voltage $V_{DD}/V_{DDA} = 3.3\text{ V} \pm 5\%$,

PARAMETER	SYMBOL	CONDITIONS	MIN	TYP	MAX	UNITS	NOTES
Output Impedance	R_{DSP}	$V_O = V_{DD}^*(0.5)$	20		60	Ω	1
Output High Voltage	V_{OH}	$I_{OH} = -1\text{ mA}$	2.4			V	1
Output Low Voltage	V_{OL}	$I_{OL} = 1\text{ mA}$			0.55	V	1
Output High Current	I_{OH}	MIN @ $V_{OH} = 1.0\text{ V}$	-29			mA	1
		MAX @ $V_{OH} = 3.135\text{ V}$			-33	mA	1
Output Low Current	I_{OL}	MIN @ $V_{OL} = 1.95\text{ V}$	29			mA	1
		MAX @ $V_{OL} = 0.4\text{ V}$			27	mA	1
Clock High Time	T_{HIGH}	1.5V	8.094		10.036	ns	1
Clock Low Time	T_{LOW}	1.5V	7.694		9.836	ns	1
Edge Rate	t_{slew/f_USB}	Rising/Falling edge rate	1	1.5	2	V/ns	1,2
Duty Cycle	d_{t1}	$V_T = 1.5\text{ V}$	45	51	55	%	1
Jitter, Cycle to cycle	$t_{jcy-cyc}$	$V_T = 1.5\text{ V}$		109	350	ps	1

See "Single-ended Test Loads Page" for termination circuits

¹Guaranteed by design and characterization, not 100% tested in production.

²Measured between 0.8V and 2.0V

Electrical Characteristics - REF

$T_A = 0 - 70^\circ\text{C}$; Supply Voltage $V_{DD}/V_{DDA} = 3.3\text{ V} \pm 5\%$,

PARAMETER	SYMBOL	CONDITIONS	MIN	TYP	MAX	UNITS	Notes
Output Impedance	R_{DSP}	$V_O = V_{DD}*(0.5)$	12		55	Ω	1
Output High Voltage	V_{OH}	$I_{OH} = -1\text{ mA}$	2.4			V	1
Output Low Voltage	V_{OL}	$I_{OL} = 1\text{ mA}$			0.55	V	1
Output High Current	I_{OH}	MIN @ $V_{OH} = 1.0\text{ V}$	-33			mA	1
		MAX @ $V_{OH} = 3.135\text{ V}$			-33	mA	1
Output Low Current	I_{OL}	MIN @ $V_{OL} = 1.95\text{ V}$	30			mA	1
		MAX @ $V_{OL} = 0.4\text{ V}$			38	mA	1
Clock High Time	T_{HIGH}	1.5V	27.5			ns	1
Clock Low Time	T_{LOW}	1.5V	27.5			ns	1
Edge Rate	$t_{sle\ wr/f}$	Rising/Falling edge rate	1	1.9	4	V/ns	1,2
Duty Cycle	d_{t1}	$V_T = 1.5\text{ V}$	45	50.5	55	%	1
Jitter, Cycle to cycle	$t_{j\text{cyc-cyc}}$	$V_T = 1.5\text{ V}$		75	1000	ps	1

See "Single-ended Test Loads Page" for termination circuits

¹Guaranteed by design and characterization, not 100% tested in production.

²Measured between 0.8V and 2.0V

Clock AC Tolerances

	SRC, NS_SAS	PCI	DOT96	48MHz	REF	
PPM tolerance	100	100	100	100	100	ppm
Cycle to Cycle Jitter	50	500	250	350	1000	ps
Spread	-0.50%	-0.50%	0	0.00%	0.00%	%

Clock Periods – Outputs with Spread Spectrum Disabled

SSC ON	Center Freq. MHz	Measurement Window							Units	Notes
		1 Clock	1 us	0.1s	0.1s	0.1s	1us	1 Clock		
		-c2c jitter AbsPer Min	-SSC Short-Term Average Min	- ppm Long-Term Average Min	0 ppm Period Nominal	+ ppm Long-Term Average Max	+SSC Short-Term Average Max	+c2c jitter AbsPer Max		
SRC, NS_SAS	100.00000	9.94900		9.99900	10.00000	10.00100		10.05100	ns	1,2
PCI	33.33333	29.49700		29.99700	30.00000	30.00300		30.50300	ns	1,2
DOT96	96.00000	10.16563		10.41563	10.41667	10.41771		10.66771	ns	1,2
48MHz	48.00000	20.48125		20.83125	20.83333	20.83542		21.18542	ns	1,2
REF	14.31818	69.78429		69.83429	69.84128	69.84826		69.89826	ns	1,2

Clock Periods – Outputs with Spread Spectrum Enabled

SSC ON	Center Freq. MHz	Measurement Window							Units	Notes
		1 Clock	1 us	0.1s	0.1s	0.1s	1us	1 Clock		
		-c2c jitter AbsPer Min	-SSC Short-Term Average Min	- ppm Long-Term Average Min	0 ppm Period Nominal	+ ppm Long-Term Average Max	+SSC Short-Term Average Max	+c2c jitter AbsPer Max		
PCI	33.25	29.49718	29.99718	30.07218	30.07519	30.07820	30.15320	30.65320	ns	1,2
SRC	99.75	9.94906	9.99906	10.02406	10.02506	10.02607	10.05107	10.10107	ns	1,2

¹Guaranteed by design and characterization, not 100% tested in production.

²All Long Term Accuracy specifications are guaranteed with the assumption that the REF output is tuned to exactly 14.31818MHz.

General SMBus Serial Interface Information

How to Write

- Controller (host) sends a start bit
- Controller (host) sends the write address
- IDT clock will **acknowledge**
- Controller (host) sends the beginning byte location = N
- IDT clock will **acknowledge**
- Controller (host) sends the byte count = X
- IDT clock will **acknowledge**
- Controller (host) starts sending Byte N through Byte N+X-1
- IDT clock will **acknowledge** each byte **one at a time**
- Controller (host) sends a Stop bit

Index Block Write Operation		
Controller (Host)		IDT (Slave/Receiver)
T	starT bit	
Slave Address		
WR	WRite	
Beginning Byte = N		ACK
		ACK
Data Byte Count = X		ACK
Beginning Byte N		ACK
O	X Byte	O
O		O
O		O
Byte N + X - 1		ACK
P	stoP bit	

SMBus write address = D2 hex

SMBus read address = D3 hex

How to Read

- Controller (host) will send a start bit
- Controller (host) sends the write address
- IDT clock will **acknowledge**
- Controller (host) sends the beginning byte location = N
- IDT clock will **acknowledge**
- Controller (host) will send a separate start bit
- Controller (host) sends the read address
- IDT clock will **acknowledge**
- IDT clock will send the data byte count = X
- IDT clock sends Byte N+X-1
- IDT clock sends **Byte 0 through Byte X (if X_(H) was written to Byte 8)**
- Controller (host) will need to acknowledge each byte
- Controller (host) will send a not acknowledge bit
- Controller (host) will send a stop bit

Index Block Read Operation		
Controller (Host)		IDT (Slave/Receiver)
T	starT bit	
Slave Address		
WR	WRite	
Beginning Byte = N		ACK
		ACK
RT	Repeat starT	
Slave Address		
RD	ReaD	
		ACK
ACK		
		Data Byte Count=X
		Beginning Byte N
O	X Byte	O
O		O
O		O
O		O
		Byte N + X - 1
N	Not acknowledge	
P	stoP bit	

SMBus Table: Output Enable Register

Byte 0	Pin #	Name	Control Function	Type	0	1	Default
Bit 7	-	DOT96 Enable	Output Enable	RW	Disable-Hi-Z	Enable	1
Bit 6	-	NS_SAS1 Enable	Output Enable	RW	Disable-Hi-Z	Enable	1
Bit 5		RESERVED					1
Bit 4	-	NS_SAS0 Enable	Output Enable	RW	Disable-Hi-Z	Enable	1
Bit 3		RESERVED					1
Bit 2	-	SRC2 Enable	Output Enable	RW	Disable-Hi-Z	Enable	1
Bit 1	-	SRC1 Enable	Output Enable	RW	Disable-Hi-Z	Enable	1
Bit 0	-	SRC0 Enable	Output Enable	RW	Disable-Hi-Z	Enable	1

SMBus Table: Output Enable Register

Byte 1	Pin #	Name	Control Function	Type	0	1	Default
Bit 7	-	REF14_3x Enable	Output Enable	RW	Disable-Low	Enable	1
Bit 6		RESERVED					0
Bit 5		RESERVED					0
Bit 4		RESERVED					1
Bit 3		RESERVED					1
Bit 2		RESERVED					1
Bit 1		RESERVED					1
Bit 0	SRC/PCI	Spread Spectrum Enable	Spread Off/On	RW	Spread Off	Spread On	0

SMBus Table: Output Enable Register

Byte 2	Pin #	Name	Control Function	Type	0	1	Default
Bit 7		RESERVED					0
Bit 6		RESERVED					0
Bit 5	-	PCI4 Enable	Output Enable	RW	Disable-Low	Enable	1
Bit 4	-	PCI3 Enable	Output Enable	RW	Disable-Low	Enable	1
Bit 3	-	PCI2 Enable	Output Enable	RW	Disable-Low	Enable	1
Bit 2	-	PCI1 Enable	Output Enable	RW	Disable-Low	Enable	1
Bit 1	-	PCI0 Enable	Output Enable	RW	Disable-Low	Enable	1
Bit 0	-	48MHz Enable	Output Enable	RW	Disable-Low	Enable	1

Byte 3 ~ Byte 4 Reserved Register

SMBus Table: NS_SAS Frequency Margining Table

Byte 5	Pin #	Name	Control Function	Type	0	1	Default
Bit 7		RESERVED					0
Bit 6		RESERVED					0
Bit 5		RESERVED					0
Bit 4	-	FS4	Freq. Sel 4	RW	See NS_SAS Frequency Table		0
Bit 3	-	FS3	Freq. Sel 3	RW		1	
Bit 2	-	FS2	Freq. Sel 2	RW		1	
Bit 1	-	FS1	Freq. Sel 1	RW		1	
Bit 0	-	FS0	Freq. Sel 0	RW		1	

SMBus Table: SRC/PCI Frequency Select Register

Byte 6	Pin #	Name	Control Function	Type	0	1	Default
Bit 7	-	RESERVED					0
Bit 6	-	RESERVED					0
Bit 5	-	RESERVED					0
Bit 4	-	RESERVED					1
Bit 3	-	FS3	Freq. Sel 3	RW	See SRC/PCI Frequency Select Table		1
Bit 2	-	FS2	Freq. Sel 2	RW		0	
Bit 1	-	FS1	Freq. Sel 1	RW		0	
Bit 0	-	FS0	Freq. Sel 0	RW		0	

SMBus Table: Vendor & Revision ID Register

Byte 7	Pin #	Name	Control Function	Type	0	1	Default
Bit 7	-	RID3	REVISION ID	R	0011 for A rev		0
Bit 6	-	RID2		R			0
Bit 5	-	RID1		R			1
Bit 4	-	RID0		R			1
Bit 3	-	VID3	VENDOR ID	R	0001 for ICS/IDT		0
Bit 2	-	VID2		R			0
Bit 1	-	VID1		R			0
Bit 0	-	VID0		R			1

SMBus Table: Byte Count Register

Byte 8	Pin #	Name	Control Function	Type	0	1	Default
Bit 7	-	BC7	Byte Count Programming b(7:0)	RW	Writing to this register will configure how many bytes will be read back, default is A bytes (0 to 9)		0
Bit 6	-	BC6		RW			0
Bit 5	-	BC5		RW			0
Bit 4	-	BC4		RW			0
Bit 3	-	BC3		RW			1
Bit 2	-	BC2		RW			0
Bit 1	-	BC1		RW			1
Bit 0	-	BC0		RW			0

SMBus Table: Device ID Register

Byte 9	Pin #	Name	Control Function	Type	0	1	Default
Bit 7		DID7	Device ID (17 hex)	R	-	-	0
Bit 6		DID6		R	-	-	0
Bit 5		DID5		R	-	-	0
Bit 4		DID4		R	-	-	1
Bit 3		DID3		R	-	-	0
Bit 2		DID2		R	-	-	1
Bit 1		DID1		R	-	-	1
Bit 0		DID0		R	-	-	1

SMBus Table: M/N Programming & Control Register

Byte 10	Pin #	Name	Control Function	Type	0	1	Default
Bit 7	-	M/N_EN	SRC M/N Programming Enable	RW	Disable	Enable	0
Bit 6	-		RESERVED				0
Bit 5	-		RESERVED				0
Bit 4	-		RESERVED				0
Bit 3	-		RESERVED				0
Bit 2	-		RESERVED				0
Bit 1	-		RESERVED				0
Bit 0	-		RESERVED				0

SMBus Table: SRC/PCI Frequency Control Register

Byte 11	Pin #	Name	Control Function	Type	0	1	Default
Bit 7	-	SRC N Div8	N Divider Prog bit 8	RW	The decimal representation of M and N Divider in Byte 11 and 12 will configure the SRC VCO frequency. Default at power up = latch-in or Byte 6 Rom table. VCO Frequency = $25 \times [N\text{Div}(9:0)+8] /$ $[M\text{Div}(5:0)+2]$		X
Bit 6	-	SRC N Div9	N Divider Prog bit 9	RW			X
Bit 5	-	SRC M Div5	M Divider Programming bit (5:0)	RW			X
Bit 4	-	SRC M Div4		RW			X
Bit 3	-	SRC M Div3		RW			X
Bit 2	-	SRC M Div2		RW			X
Bit 1	-	SRC M Div1		RW			X
Bit 0	-	SRC M Div0		RW			X

SMBus Table: SRC Frequency Control Register

Byte 12	Pin #	Name	Control Function	Type	0	1	Default
Bit 7	-	SRC N Div7	N Divider Programming Byte12 bit(7:0) and Byte11 bit(7:6)	RW	The decimal representation of M and N Divider in Byte 11 and 12 will configure the SRC VCO frequency. Default at power up = latch-in or Byte 6 Rom table. VCO Frequency = 25 x [NDiv(9:0)+8] / [MDiv(5:0)+2]		X
Bit 6	-	SRC N Div6		RW			X
Bit 5	-	SRC N Div5		RW			X
Bit 4	-	SRC N Div4		RW			X
Bit 3	-	SRC N Div3		RW			X
Bit 2	-	SRC N Div2		RW			X
Bit 1	-	SRC N Div1		RW			X
Bit 0	-	SRC N Div0		RW			X

SMBus Table: SRC Spread Spectrum Control Register

Byte 13	Pin #	Name	Control Function	Type	0	1	Default
Bit 7	-	SRC SSP7	Spread Spectrum Programming bit(7:0)	RW	These Spread Spectrum bits in Byte 13 and 14 will program the spread percentage of SRC		X
Bit 6	-	SRC SSP6		RW			X
Bit 5	-	SRC SSP5		RW			X
Bit 4	-	SRC SSP4		RW			X
Bit 3	-	SRC SSP3		RW			X
Bit 2	-	SRC SSP2		RW			X
Bit 1	-	SRC SSP1		RW			X
Bit 0	-	SRC SSP0		RW			X

SMBus Table: SRC Spread Spectrum Control Register

Byte 14	Pin #	Name	Control Function	Type	0	1	Default
Bit 7	-		Reserved				0
Bit 6	-	SRC SSP14	Spread Spectrum Programming bit(14:8)	RW	These Spread Spectrum bits in Byte 13 and 14 will program the spread percentage of SRC		X
Bit 5	-	SRC SSP13		RW			X
Bit 4	-	SRC SSP12		RW			X
Bit 3	-	SRC SSP11		RW			X
Bit 2	-	SRC SSP10		RW			X
Bit 1	-	SRC SSP9		RW			X
Bit 0	-	SRC SSP8		RW			X

SMBus Table: NS_SAS Frequency Control Register

Byte 15	Pin #	Name	Control Function	Type	0	1	Default
Bit 7	-	NS_SAS N Div8	N Divider Prog bit 8	RW	The decimal representation of M and N Divider in Byte 15 and 16 will configure the NS_SAS VCO frequency. Default at power up = latch-in or Byte 0 Rom table. VCO Frequency = 25 x [NDiv(9:0)+8] / [MDiv(5:0)+2]		X
Bit 6	-	NS_SAS N Div9	N Divider Prog bit 9	RW			X
Bit 5	-	NS_SAS M Div5	M Divider Programming bits (Fixed at 1 for Rev D)	RW			X
Bit 4	-	NS_SAS M Div4		RW			X
Bit 3	-	NS_SAS M Div3		RW			X
Bit 2	-	NS_SAS M Div2		RW			X
Bit 1	-	NS_SAS M Div1		RW			X
Bit 0	-	NS_SAS M Div0		RW			X

SMBus Table: NS_SAS Frequency Control Register

Byte 16	Pin #	Name	Control Function	Type	0	1	Default
Bit 7	-	NS_SAS N Div7	N Divider Programming b(7:0)	RW	The decimal representation of M and N Divider in Byte 15 and 16 will configure the NS_SAS VCO frequency. Default at power up = latch-in or Byte 0 Rom table. VCO Frequency = 25 x [NDiv(9:0)+8] / [MDiv(5:0)+2]		X
Bit 6	-	NS_SAS N Div6		RW			X
Bit 5	-	NS_SAS N Div5		RW			X
Bit 4	-	NS_SAS N Div4		RW			X
Bit 3	-	NS_SAS N Div3		RW			X
Bit 2	-	NS_SAS N Div2		RW			X
Bit 1	-	NS_SAS N Div1		RW			X
Bit 0	-	NS_SAS N Div0		RW			X

SRC/PCI Frequency Selection Table

Line	Byte 1, Bit 0 Spread Enable	Byte6 Bit3 FS3	Byte6 Bit2 FS2	Byte6 Bit1 FS1	Byte6 Bit0 FS0	SRC (MHz)	PCI (MHz)	Spread %
0	0	0	0	0	0	89.97	29.99	0%
1	0	0	0	0	1	91.28	30.43	
2	0	0	0	1	0	92.58	30.86	
3	0	0	0	1	1	93.75	31.25	
4	0	0	1	0	0	95.05	31.68	
5	0	0	1	0	1	96.22	32.07	
6	0	0	1	1	0	97.53	32.51	
7	0	0	1	1	1	98.83	32.94	
8	0	1	0	0	0	100.00	33.33	
9	0	1	0	0	1	101.30	33.77	
10	0	1	0	1	0	102.47	34.16	
11	0	1	0	1	1	103.78	34.59	
12	0	1	1	0	0	105.08	35.03	
13	0	1	1	0	1	106.25	35.42	
14	0	1	1	1	0	107.55	35.85	
15	0	1	1	1	1	110.03	36.68	
16	1	0	0	0	0	89.97	29.99	-0.5%
17	1	0	0	0	1	91.28	30.43	
18	1	0	0	1	0	92.58	30.86	
19	1	0	0	1	1	93.75	31.25	
20	1	0	1	0	0	95.05	31.68	
21	1	0	1	0	1	96.22	32.07	
22	1	0	1	1	0	97.53	32.51	
23	1	0	1	1	1	98.83	32.94	
24	1	1	0	0	0	100.00	33.33	
25	1	1	0	0	1	101.30	33.77	
26	1	1	0	1	0	102.47	34.16	
27	1	1	0	1	1	103.78	34.59	
28	1	1	1	0	0	105.08	35.03	
29	1	1	1	0	1	106.25	35.42	
30	1	1	1	1	0	107.55	35.85	
31	1	1	1	1	1	110.03	36.68	

NS_SAS Margining Table

Line	Byte5 Bit4 FS4	Byte5 Bit3 FS3	Byte5 Bit2 FS2	Byte5 Bit1 FS1	Byte5 Bit0 FS0	NS_xxx (MHz)
0	0	0	0	0	0	58.33
1	0	0	0	0	1	61.11
2	0	0	0	1	0	63.89
3	0	0	0	1	1	66.67
4	0	0	1	0	0	69.44
5	0	0	1	0	1	72.22
6	0	0	1	1	0	75.00
7	0	0	1	1	1	77.78
8	0	1	0	0	0	80.56
9	0	1	0	0	1	83.33
10	0	1	0	1	0	86.11
11	0	1	0	1	1	88.89
12	0	1	1	0	0	91.67
13	0	1	1	0	1	94.44
14	0	1	1	1	0	97.22
15	0	1	1	1	1	100.00
16	1	0	0	0	0	102.78
17	1	0	0	0	1	105.56
18	1	0	0	1	0	108.33
19	1	0	0	1	1	111.11
20	1	0	1	0	0	113.89
21	1	0	1	0	1	116.67
22	1	0	1	1	0	119.44
23	1	0	1	1	1	122.22
24	1	1	0	0	0	125.00
25	1	1	0	0	1	127.78
26	1	1	0	1	0	130.56
27	1	1	0	1	1	133.33
28	1	1	1	0	0	136.11
29	1	1	1	0	1	138.89
30	1	1	1	1	0	141.67
31	1	1	1	1	1	144.44

NOTE: Operation at other than the default entry is not guaranteed. These values are for margining purposes only.

DIF Reference Clock			
Common Recommendations for Differential Routing	Dimension or Value	Unit	Figure
L1 length, route as non-coupled 50ohm trace	0.5 max	inch	1
L2 length, route as non-coupled 50ohm trace	0.2 max	inch	1
L3 length, route as non-coupled 50ohm trace	0.2 max	inch	1
R_s	33	ohm	1
R_t	49.9	ohm	1

Down Device Differential Routing			
L4 length, route as coupled microstrip 100ohm differential trace	2 min to 16 max	inch	1
L4 length, route as coupled stripline 100ohm differential trace	1.8 min to 14.4 max	inch	1

Differential Routing to PCI Express Connector			
L4 length, route as coupled microstrip 100ohm differential trace	0.25 to 14 max	inch	2
L4 length, route as coupled stripline 100ohm differential trace	0.225 min to 12.6 max	inch	2

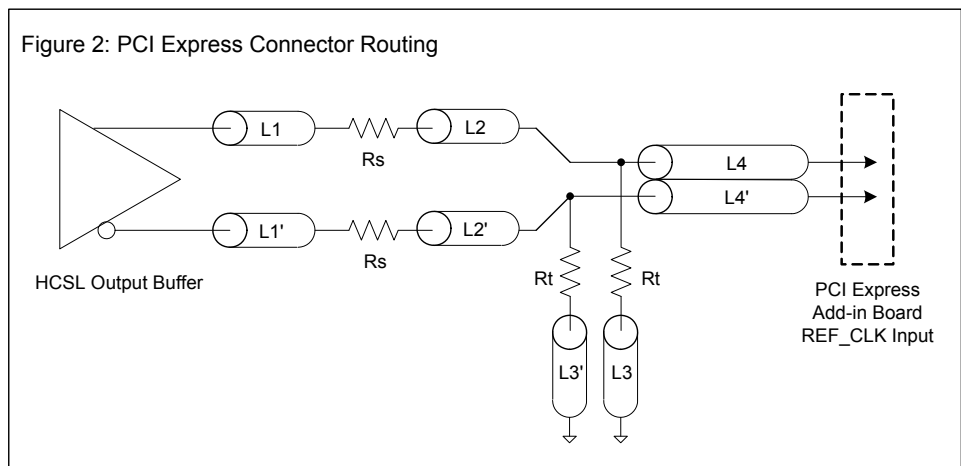
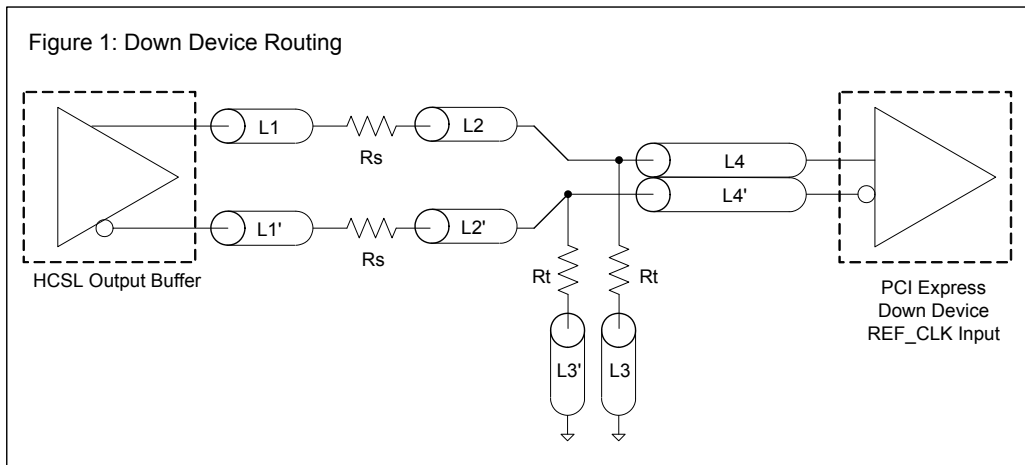

Alternative Termination for LVDS and other Common Differential Signals (figure 3)

Vdiff	Vp-p	Vcm	R1	R2	R3	R4	Note
0.45v	0.22v	1.08	33	150	100	100	
0.58	0.28	0.6	33	78.7	137	100	
0.80	0.40	0.6	33	78.7	none	100	ICS874003i-02 input compatible
0.60	0.3	1.2	33	174	140	100	Standard LVDS

R1a = R1b = R1

R2a = R2b = R2

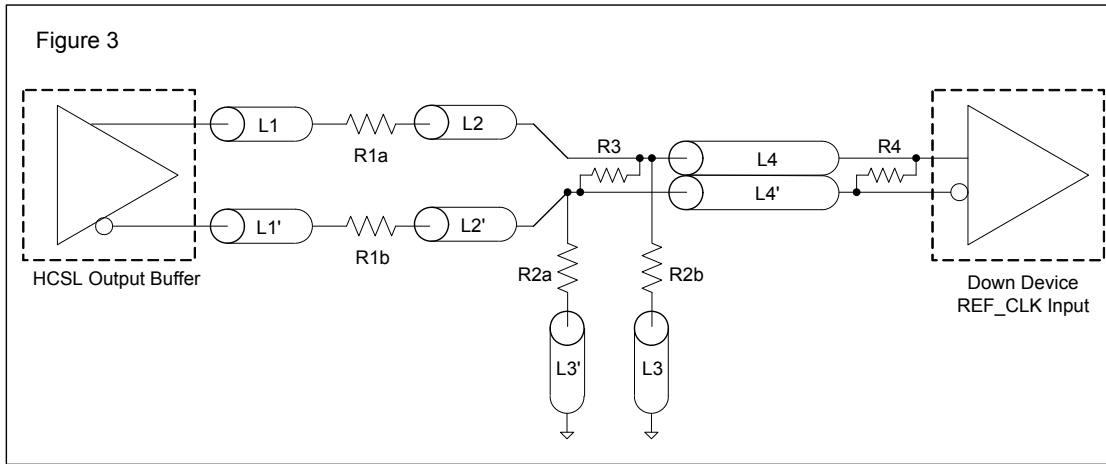

Cable Connected AC Coupled Application (figure 4)

Component	Value	Note
R5a, R5b	8.2K 5%	
R6a, R6b	1K 5%	
Cc	0.1 μ F	
Vcm	0.350 volts	

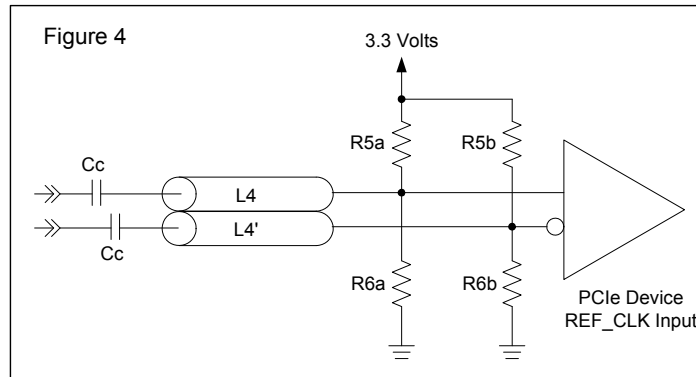

Package Outline and Package Dimensions (48-pin MLF)

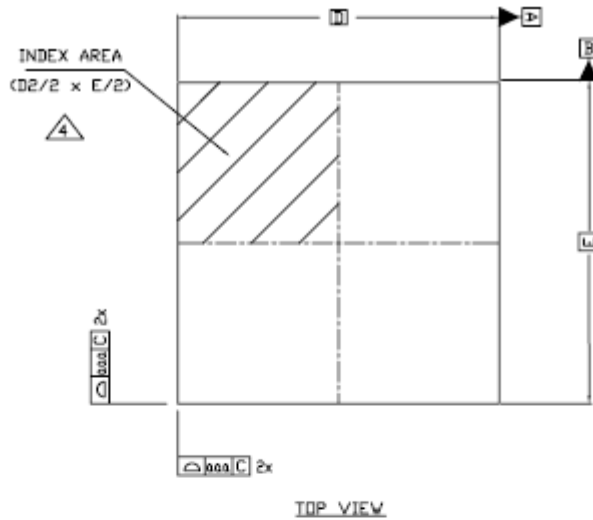

SYMBOL	DIMENSION		
	MIN	NOM	MAX
D2	3.95	4.10	4.20
E2	3.95	4.10	4.20
L	0.30	0.40	0.50
D	6.00 BSC		
E	6.00 BSC		
e	0.40 BSC		
A	0.80	0.90	1.00
A1	0.00	0.02	0.05
A3	---	0.20 ref	---
N	48		
ND	12		
NE	12		
b	.15	.20	.25

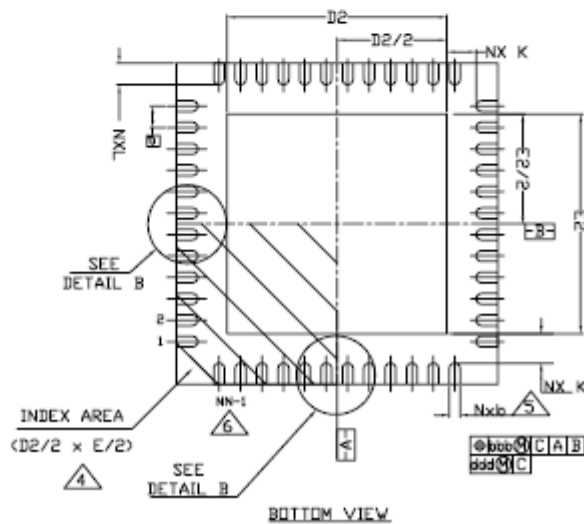
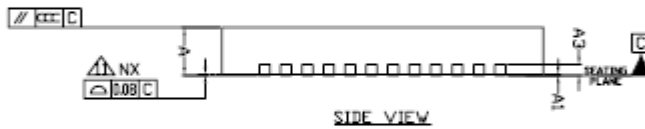
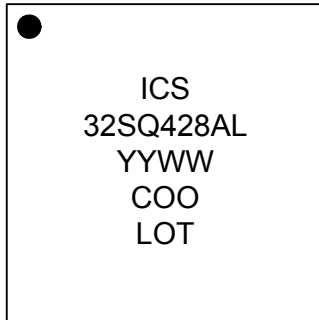

FIGURE 1
B 9

1. ALL DIMENSIONING AND TOLERANCING CONFORM TO ANSI Y14.5M-1982
2. ALL DIMENSIONS ARE IN MILLIMETERS.
3. N REFERS TO THE NUMBER OF LEADS.
4. ND AND NE REFER TO THE NUMBER OF LEADS PER SIDE.

Marking Diagram



Notes:

1. 'L' denotes RoHS compliant package.
2. 'YYWW' is the date code.
3. 'COO' is the country of origin.
4. 'LOT' is the lot number.

Ordering Information

Part / Order Number	Shipping Packaging	Package	Temperature
932SQ428AKLF	Tray	48-pin MLF	0 to +70° C
932SQ428AKLFT	Tape and Reel	48-pin MLF	0 to +70° C

"LF" suffix to the part number are the Pb-Free configuration, RoHS compliant.

"A" is the device revision designator (will not correlate with the datasheet revision).

While the information presented herein has been checked for both accuracy and reliability, Integrated Device Technology (IDT) assumes no responsibility for either its use or for the infringement of any patents or other rights of third parties, which would result from its use. No other circuits, patents, or licenses are implied. This product is intended for use in normal commercial applications. Any other applications such as those requiring extended temperature range, high reliability, or other extraordinary environmental requirements are not recommended without additional processing by IDT. IDT reserves the right to change any circuitry or specifications without notice. IDT does not authorize or warrant any IDT product for use in life support devices or critical medical instruments.

Revision History

Rev.	Issue Date	Who	Description	Page #
A	4/15/2011	RDW	Updated Idd, phase jitter, minor typo corrections; released to final	
B	7/26/2011	RDW	Updated Power Down Functionality table to clarify functionality of single-ended outputs in power down.	
C	12/8/2011	RDW	1. Updated Phase Jitter Table to correct typo in "Conditions" column for SAS. 2. Mark spec added.	8, 21
D	4/13/2012	AT	Typo on pin 40 description. Pin type states OUT; should be IN	4
E	4/23/2012	RDW	Updated Rp values on Output Terminations Table from 43.2 ohms to 42.2 or 43.2 ohms to be consistent with Intel.	5

Innovate with IDT and accelerate your future networks. Contact:

www.IDT.com

For Sales

800-345-7015
408-284-8200
Fax: 408-284-2775

For Tech Support

www.idt.com/go/clockhelp
pcclockhelp@idt.com

Corporate Headquarters

Integrated Device Technology, Inc.
www.idt.com



Looking for pricing, stock, or lifecycle information?

Click below to explore more details on WIN SOURCE:

- ⊖ [View 932SQ428AKLF on WIN SOURCE](#)
- ⊖ [IDT, Integrated Device Technology Inc Information](#)

Optimize Your Supply Chain with WIN SOURCE Solutions

- ✓ Global Sourcing Solution
- ✓ Obsolete Management
- ✓ Cost Control Management
- ✓ Shortage Management
- ✓ Alternative Solution
- ✓ Excess Inventory Management