



**THE DATASHEET OF  
ICS853006AGLFT**



# LOW SKEW, 1-TO-6 DIFFERENTIAL-TO-2.5V/3.3V LVPECL/ECL FANOUT BUFFER

**ICS853006**

## GENERAL DESCRIPTION



The ICS853006 is a low skew, high performance 1-to-6 Differential-to-2.5V/3.3V LVPECL/ECL Fanout Buffer and a member of the HiPerClock<sup>SM</sup> family of High Performance Clock Solutions from ICS. The ICS853006 is characterized to operate from a 2.5V or a 3.3V power supply. Guaranteed output and part-to-part skew characteristics make the ICS853006 ideal for those applications demanding well defined performance and repeatability.

## FEATURES

- 6 differential LVPECL outputs
- 1 differential PCLK, nPCLK input pair
- PCLK, nPCLK pair can accept the following differential input levels: LVPECL, LVDS, CML, SSTL
- Maximum output frequency: > 2GHz
- Output skew: 30ps (maximum)
- Part-to-part skew: 150ps (maximum)
- Propagation delay: 510ps (maximum)
- Jitter, RMS: < 0.03ps (typical)
- LVPECL mode operating voltage supply range:  $V_{CC} = 2.375V$  to  $3.465V$ ,  $V_{EE} = 0V$
- ECL mode operating voltage supply range:  $V_{CC} = 0V$ ,  $V_{EE} = -2.375V$  to  $-3.465V$
- Lead-Free package available
- -40°C to 85°C ambient operating temperature

## BLOCK DIAGRAM

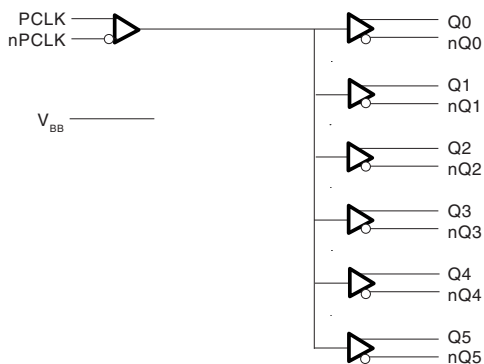

## PIN ASSIGNMENT



**ICS853006**  
**20-Lead TSSOP**  
 6.5mm x 4.4mm x 0.92mm package body  
**G Package**  
 Top View

TABLE 1. PIN DESCRIPTIONS

Number	Name	Type		Description
1, 8, 13, 20	V <sub>CC</sub>	Power		Positive supply pins.
2, 3	nQ0, Q0	Output		Differential output pair. LVPECL interface levels.
4, 5	nQ1, Q1	Output		Differential output pair. LVPECL interface levels.
6, 7	nQ2, Q2	Output		Differential output pair. LVPECL interface levels.
9	PCLK	Input	Pulldown	Non-inverting differential LVPECL clock input.
10	nPCLK	Input	Pullup/ Pulldown	Inverting differential LVPECL clock input. V <sub>CC</sub> /2 default when left floating.
11	V <sub>BB</sub>	Output		Bias voltage.
12	V <sub>EE</sub>	Power		Negative supply pin.
14, 15	nQ3, Q3	Output		Differential output pair. LVPECL interface levels.
16, 17	nQ4, Q4	Output		Differential output pair. LVPECL interface levels.
18, 19	nQ5, Q5	Output		Differential output pair. LVPECL interface levels.

NOTE: *Pulldown* refers to internal input resistors. See Table 2, Pin Characteristics, for typical values.

TABLE 2. PIN CHARACTERISTICS

Symbol	Parameter	Test Conditions	Minimum	Typical	Maximum	Units
R <sub>PULLDOWN</sub>	Input Pulldown Resistor			75		KΩ
R <sub>VCC/2</sub>	Input Pullup/Pulldown Resistor			50		KΩ

TABLE 3. CLOCK INPUT FUNCTION TABLE

Input		Outputs		Input to Output Mode	Polarity
PCLK	nPCLK	Q0:Q5	nQ0:nQ5		
0	1	LOW	HIGH	Differential to Differential	Non Inverting
1	0	HIGH	LOW	Differential to Differential	Non Inverting
0	Biased; NOTE 1	LOW	HIGH	Single Ended to Differential	Non Inverting
1	Biased; NOTE 1	HIGH	LOW	Single Ended to Differential	Non Inverting
Biased; NOTE 1	0	HIGH	LOW	Single Ended to Differential	Inverting
Biased; NOTE 1	1	LOW	HIGH	Single Ended to Differential	Inverting

NOTE 1: Please refer to the Application Information section, "Wiring the Differential Input to Accept Single Ended Levels".

**ABSOLUTE MAXIMUM RATINGS**

Supply Voltage, $V_{CC}$	4.6V (LVPECL mode, $V_{EE} = 0$ )
Negative Supply Voltage, $V_{EE}$	-4.6V (ECL mode, $V_{CC} = 0$ )
Inputs, $V_I$ (LVPECL mode)	-0.5V to $V_{CC} + 0.5$ V
Inputs, $V_I$ (ECL mode)	0.5V to $V_{EE} - 0.5$ V
Outputs, $I_O$	
Continuous Current	50mA
Surge Current	100mA
$V_{BB}$ Sink/Source, $I_{BB}$	$\pm 0.5$ mA
Operating Temperature Range, $T_A$	-40°C to +85°C
Storage Temperature, $T_{STG}$	-65°C to 150°C
Package Thermal Impedance, $\theta_{JA}$ (Junction-to-Ambient)	73.2°C/W (0 lfpm)

**NOTE:** Stresses beyond those listed under Absolute Maximum Ratings may cause permanent damage to the device. These ratings are stress specifications only. Functional operation of product at these conditions or any conditions beyond those listed in the *DC Characteristics* or *AC Characteristics* is not implied. Exposure to absolute maximum rating conditions for extended periods may affect product reliability.

**TABLE 4A. POWER SUPPLY DC CHARACTERISTICS,  $V_{CC} = 2.375$  V TO 3.465V;  $V_{EE} = 0$  V**

Symbol	Parameter	Test Conditions	Minimum	Typical	Maximum	Units
$V_{CC}$	Positive Supply Voltage		2.375	3.3	3.465	V
$I_{EE}$	Power Supply Current				115	mA

**TABLE 4B. LVPECL DC CHARACTERISTICS,  $V_{CC} = 3.3$  V;  $V_{EE} = 0$  V**

Symbol	Parameter	-40°C			25°C			85°C			Units
		Min	Typ	Max	Min	Typ	Max	Min	Typ	Max	
$V_{OH}$	Output High Voltage; NOTE 1	2.175	2.275	2.38	2.225	2.295	2.37	2.295	2.33	2.365	V
$V_{OL}$	Output Low Voltage; NOTE 1	1.405	1.545	1.68	1.425	1.52	1.615	1.44	1.535	1.63	V
$V_{IH}$	Input High Voltage(Single-Ended)	2.075		2.36	2.075		2.36	2.075		2.36	V
$V_{IL}$	Input Low Voltage(Single-Ended)	1.43		1.765	1.43		1.765	1.43		1.765	V
$V_{BB}$	Output Voltage Reference; NOTE 2	1.86		1.98	1.86		1.98	1.86		1.98	V
$V_{PP}$	Peak-to-Peak Input Voltage	150	800	1200	150	800	1200	150	800	1200	mV
$V_{CMR}$	Input High Voltage Common Mode Range; NOTE 3, 4	1.2		3.3	1.2		3.3	1.2		3.3	V
$I_{IH}$	Input High Current	PCLK, nPCLK		150			150			150	$\mu$ A
$I_{IL}$	Input Low Current	PCLK		-10			-10			-10	$\mu$ A
		nPCLK		-150			-150			-150	$\mu$ A

Input and output parameters vary 1:1 with  $V_{CC}$ .  $V_{EE}$  can vary +0.925V to -0.5V.

NOTE 1: Outputs terminated with 50 $\Omega$  to  $V_{CC} - 2$ V.

NOTE 2: Single-ended input operation is limited.  $V_{CC} \geq 3$ V in LVPECL mode.

NOTE 3: Common mode voltage is defined as  $V_{IH}$ .

NOTE 4: For single-ended applications, the maximum input voltage for PCLK, nPCLK is  $V_{CC} + 0.3$ V.

TABLE 4C. LVPECL DC CHARACTERISTICS,  $V_{CC} = 2.5V$ ;  $V_{EE} = 0V$ 

Symbol	Parameter	-40°C			25°C			85°C			Units
		Min	Typ	Max	Min	Typ	Max	Min	Typ	Max	
$V_{OH}$	Output High Voltage; NOTE 1	1.375	1.475	1.58	1.425	1.495	1.57	1.495	1.53	1.565	V
$V_{OL}$	Output Low Voltage; NOTE 1	0.605	0.745	0.88	0.625	0.72	0.815	0.64	0.735	0.83	V
$V_{IH}$	Input High Voltage(Single-Ended)	1.275		1.56	1.275		1.56	1.275		-0.83	V
$V_{IL}$	Input Low Voltage(Single-Ended)	0.63		0.965	0.63		0.965	0.63		0.965	V
$V_{PP}$	Peak-to-Peak Input Voltage	150	800	1200	150	800	1200	150	800	1200	mV
$V_{CMR}$	Input High Voltage Common Mode Range; NOTE 3, 4	1.2		2.5	1.2		2.5	1.2		2.5	V
$I_{IH}$	Input High Current	PCLK0, nPCLK		150			150			150	$\mu A$
$I_{IL}$	Input Low Current	PCLK		-10			-10			-10	$\mu A$
		nPCLK		-150			-150			-150	$\mu A$

Input and output parameters vary 1:1 with  $V_{CC}$ .  $V_{EE}$  can vary +0.925V to -0.5V.

NOTE 1: Outputs terminated with 50 $\Omega$  to  $V_{CC} - 2V$ .

NOTE 2: Single-ended input operation is limited.  $V_{CC} \geq 3V$  in LVPECL mode.

NOTE 3: Common mode voltage is defined as  $V_{IH}$ .

NOTE 4: For single-ended applications, the maximum input voltage for PCLK, nPCLK is  $V_{CC} + 0.3V$ .

TABLE 4D. ECL DC CHARACTERISTICS,  $V_{CC} = 0V$ ;  $V_{EE} = -3.465V$  TO  $-2.375V$ 

Symbol	Parameter	-40°C			25°C			85°C			Units
		Min	Typ	Max	Min	Typ	Max	Min	Typ	Max	
$V_{OH}$	Output High Voltage; NOTE 1	-1.125	-1.025	-0.92	-1.075	-1.005	-0.93	-1.005	-0.97	-0.935	V
$V_{OL}$	Output Low Voltage; NOTE 1	-1.895	-1.755	-1.62	-1.875	-1.78	-1.685	-1.86	-1.765	-1.67	V
$V_{IH}$	Input High Voltage(Single-Ended)	-1.225		-0.94	-1.225		-0.94	-1.225		-0.94	V
$V_{IL}$	Input Low Voltage(Single-Ended)	-1.87		-1.535	-1.87		-1.535	-1.87		-1.535	V
$V_{BB}$	Output Voltage Reference; NOTE 2	-1.44		-1.32	-1.44		-1.32	-1.44		-1.32	V
$V_{PP}$	Peak-to-Peak Input Voltage	150	800	1200	150	800	1200	150	800	1200	mV
$V_{CMR}$	Input High Voltage Common Mode Range; NOTE 3, 4	$V_{EE}+1.2V$		0	$V_{EE}+1.2V$		0	$V_{EE}+1.2V$		0	V
$I_{IH}$	Input High Current	PCLK, nPCLK		150			150			150	$\mu A$
$I_{IL}$	Input Low Current	PCLK		-10			-10			-10	$\mu A$
		nPCLK		-150			-150			-150	$\mu A$

Input and output parameters vary 1:1 with  $V_{CC}$ .  $V_{EE}$  can vary +0.925V to -0.5V.

NOTE 1: Outputs terminated with 50 $\Omega$  to  $V_{CC} - 2V$ .

NOTE 2: Single-ended input operation is limited.  $V_{CC} \geq 3V$  in LVPECL mode.

NOTE 3: Common mode voltage is defined as  $V_{IH}$ .

NOTE 4: For single-ended applications, the maximum input voltage for PCLK, nPCLK is  $V_{CC} + 0.3V$ .

TABLE 5. AC CHARACTERISTICS,  $V_{CC} = 0V$ ;  $V_{EE} = -2.375V$  TO  $-3.465V$  OR  $V_{CC} = 2.375$  TO  $3.465V$ ;  $V_{EE} = 0V$ 

Symbol	Parameter	-40°C			25°C			85°C			Units
		Min	Typ	Max	Min	Typ	Max	Min	Typ	Max	
$f_{MAX}$	Output Frequency		>2			>2			>2		GHz
$t_{PD}$	Propagation Delay; NOTE 1	340	400	460	350	410	470	390	450	510	ps
$tsk(o)$	Output Skew; NOTE 2, 4		15	27		15	27		17	30	ps
$tsk(pp)$	Part-to-Part Skew; NOTE 3, 4			150			150			150	ps
$f_{jit}$	Buffer Additive Phase Jitter, RMS; refer to Additive Phase Jitter section		0.03			0.03			0.03		ps
$t_R/t_F$	Output Rise/Fall Time 20% to 80%	95	150	205	95	150	205	95	150	205	ps

All parameters are measured  $\leq 1GHz$  unless otherwise noted.

NOTE 1: Measured from the differential input crossing point to the differential output crossing point.

NOTE 2: Defined as skew between outputs at the same supply voltage and with equal load conditions.

Measured at the output differential cross points.

NOTE 3: Defined as skew between outputs on different devices operating at the same supply voltages and with equal load conditions. Using the same type of inputs on each device, the outputs are measured at the differential cross points.

NOTE 4: This parameter is defined in accordance with JEDEC Standard 65.

## ADDITIVE PHASE JITTER

The spectral purity in a band at a specific offset from the fundamental compared to the power of the fundamental is called the ***dBc Phase Noise***. This value is normally expressed using a Phase noise plot and is most often the specified plot in many applications. Phase noise is defined as the ratio of the noise power present in a 1Hz band at a specified offset from the fundamental frequency to the power value of the fundamental. This ratio is expressed in decibels (dBm) or a ratio of the power in

the 1Hz band to the power in the fundamental. When the required offset is specified, the phase noise is called a ***dBc*** value, which simply means dBm at a specified offset from the fundamental. By investigating jitter in the frequency domain, we get a better understanding of its effects on the desired application over the entire time record of the signal. It is mathematically possible to calculate an expected bit error rate given a phase noise plot.

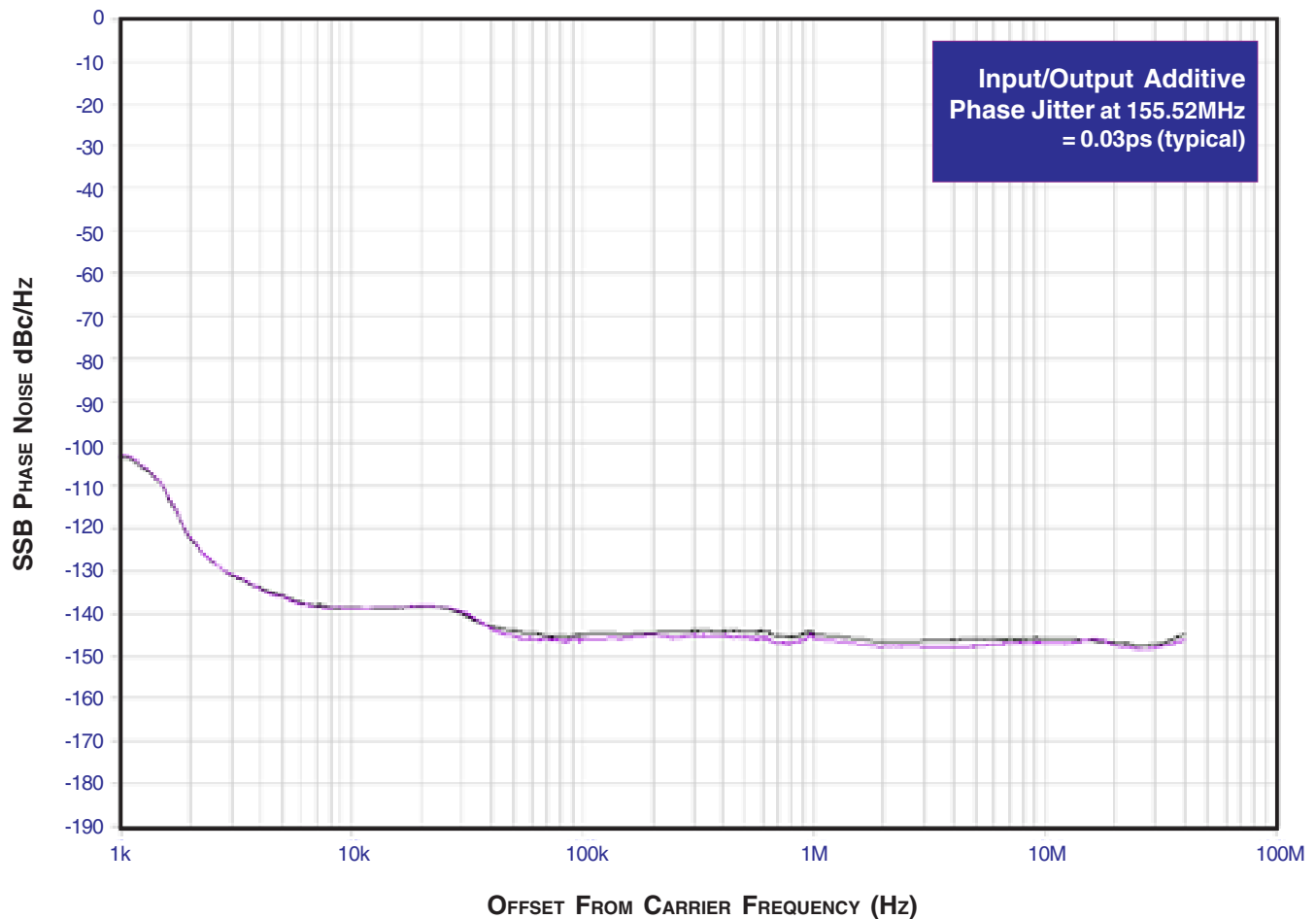

As with most timing specifications, phase noise measurements have issues. The primary issue relates to the limitations of the equipment. Often the noise floor of the equipment is higher than the noise floor of the device. This is illustrated above. The de-

vice meets the noise floor of what is shown, but can actually be lower. The phase noise is dependant on the input source and measurement equipment.

## PARAMETER MEASUREMENT INFORMATION

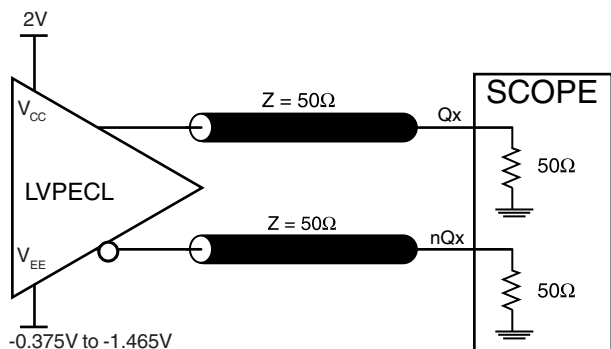

OUTPUT LOAD AC TEST CIRCUIT

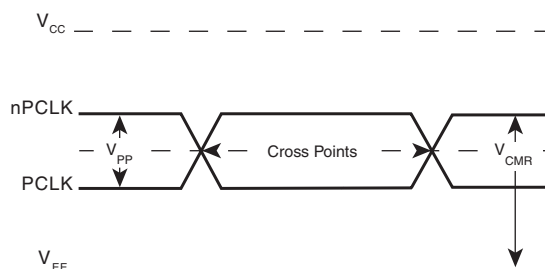

DIFFERENTIAL INPUT LEVEL

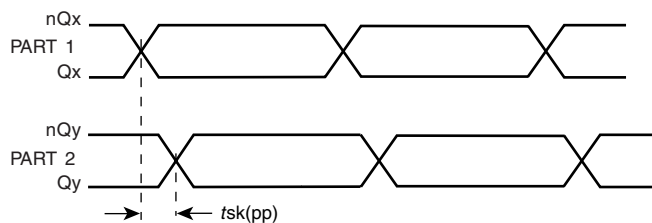

PART-TO-PART SKEW

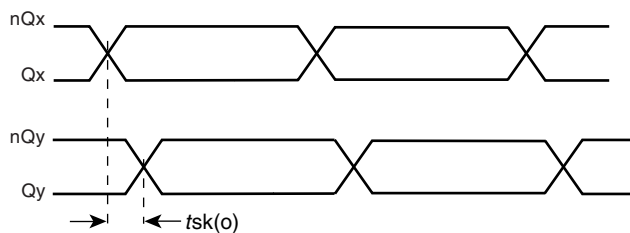

OUTPUT SKEW

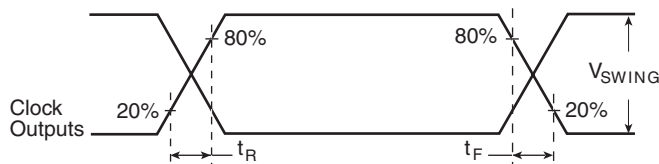

OUTPUT RISE/FALL TIME

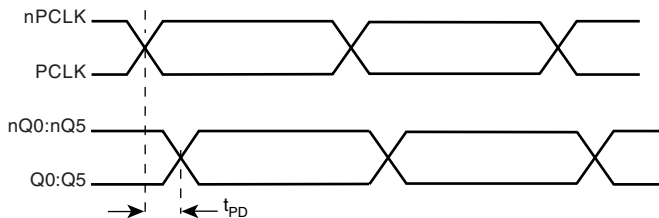

PROPAGATION DELAY

## APPLICATION INFORMATION

### WIRING THE DIFFERENTIAL INPUT TO ACCEPT SINGLE ENDED LEVELS

Figure 1 shows an example of the differential input that can be wired to accept single ended levels. The reference voltage level  $V_{BB}$  generated from the device is connected to the negative input.

The C1 capacitor should be located as close as possible to the input pin.

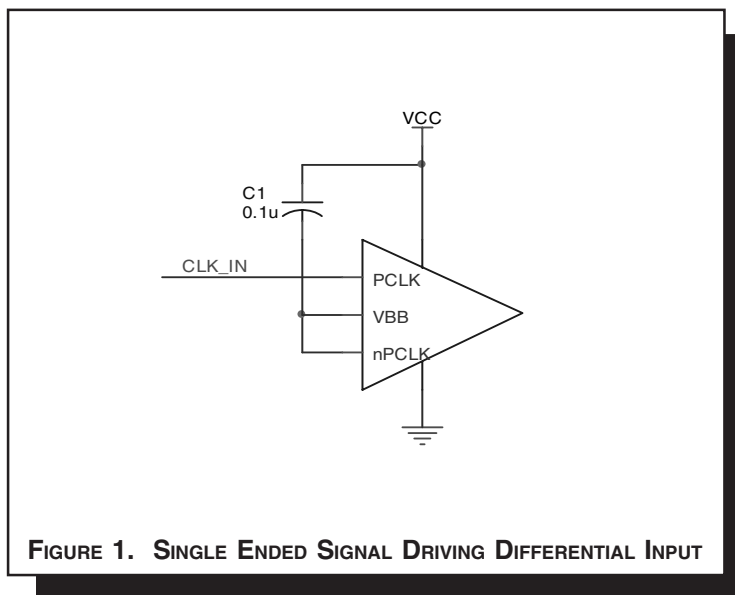

### TERMINATION FOR 3.3V LVPECL OUTPUTS

The clock layout topology shown below is a typical termination for LVPECL outputs. The two different layouts mentioned are recommended only as guidelines.

FOUT and nFOUT are low impedance follower outputs that generate ECL/LVPECL compatible outputs. Therefore, terminating resistors (DC current path to ground) or current sources must be used for functionality. These outputs are designed to drive

50Ω transmission lines. Matched impedance techniques should be used to maximize operating frequency and minimize signal distortion. Figures 2A and 2B show two different layouts which are recommended only as guidelines. Other suitable clock layouts may exist and it would be recommended that the board designers simulate to guarantee compatibility across all printed circuit and clock component process variations.

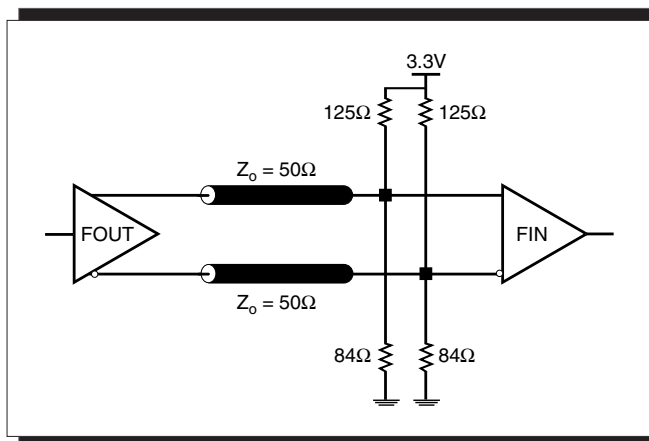
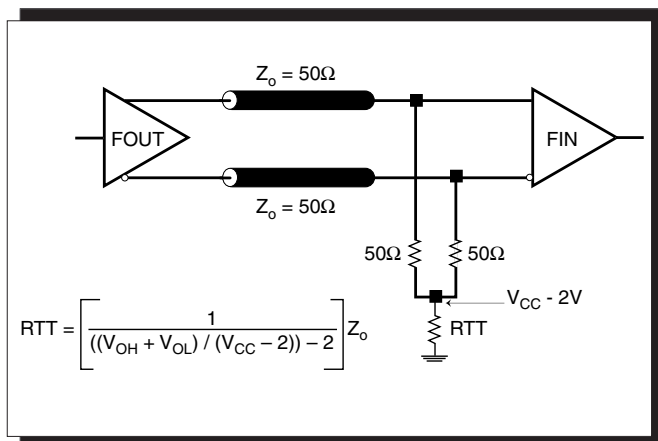

**TERMINATION FOR 2.5V LVPECL OUTPUT**

Figure 3A and Figure 3B show examples of termination for 2.5V LVPECL driver. These terminations are equivalent to terminating 50Ω to  $V_{CC} - 2V$ . For  $V_{CC} = 2.5V$ , the  $V_{CC} - 2V$  is very close to

ground level. The R3 in Figure 3B can be eliminated and the termination is shown in Figure 3C.

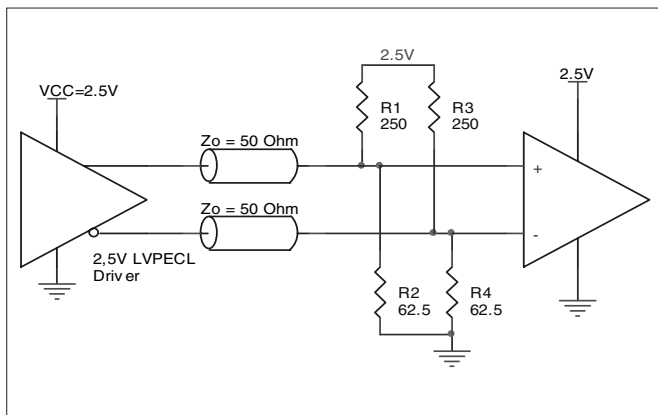

**FIGURE 3A. 2.5V LVPECL DRIVER TERMINATION EXAMPLE**

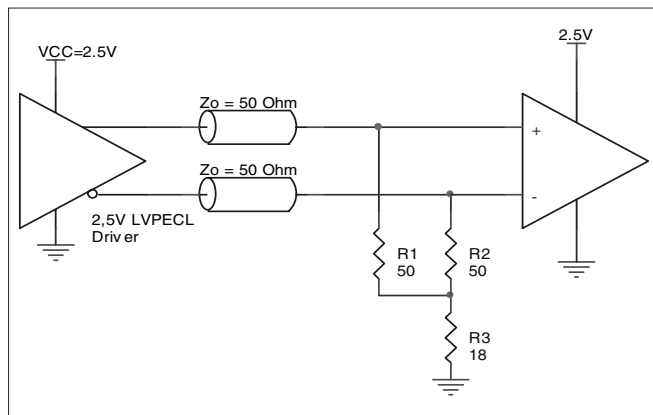

**FIGURE 3B. 2.5V LVPECL DRIVER TERMINATION EXAMPLE**

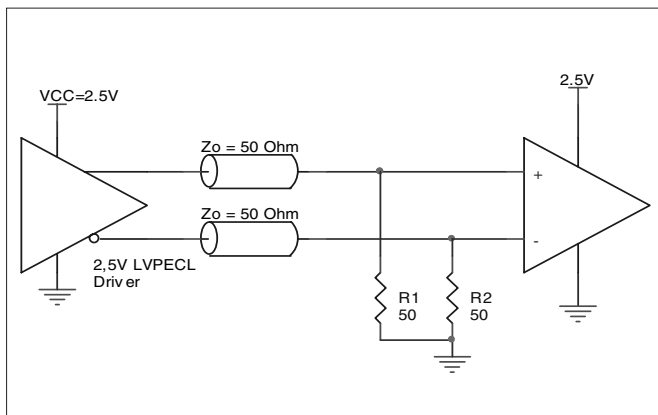

**FIGURE 3C. 2.5V LVPECL TERMINATION EXAMPLE**

### LVPECL CLOCK INPUT INTERFACE

The PCLK /nPCLK accepts LVPECL, CML, SSTL and other differential signals. Both  $V_{SWING}$  and  $V_{OH}$  must meet the  $V_{PP}$  and  $V_{CMR}$  input requirements. Figures 4A to 4F show interface examples for the HiPerClockS PCLK/nPCLK input driven by the most common driver types. The input interfaces suggested

here are examples only. If the driver is from another vendor, use their termination recommendation. Please consult with the vendor of the driver component to confirm the driver termination requirements.

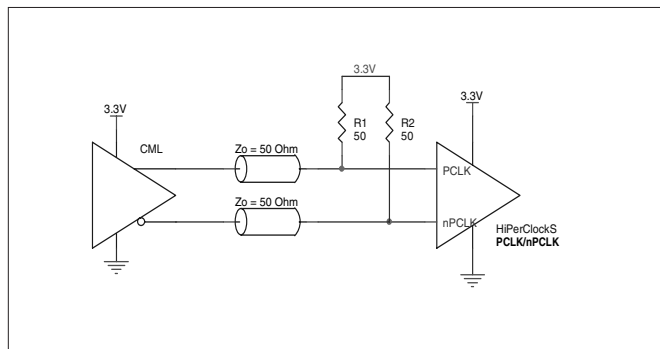

FIGURE 4A. HiPerClockS PCLK/nPCLK INPUT DRIVEN BY AN OPEN COLLECTOR CML DRIVER

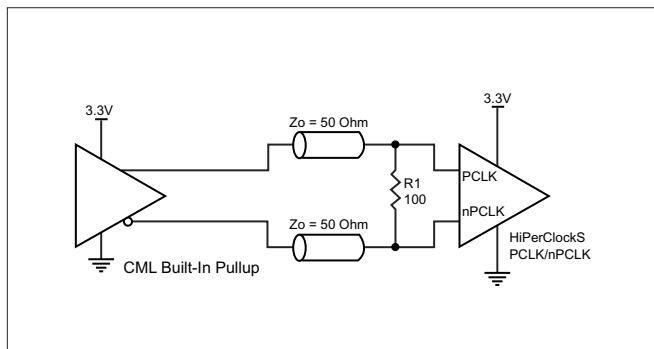

FIGURE 4B. HiPerClockS PCLK/nPCLK INPUT DRIVEN BY A BUILT-IN PULLUP CML DRIVER

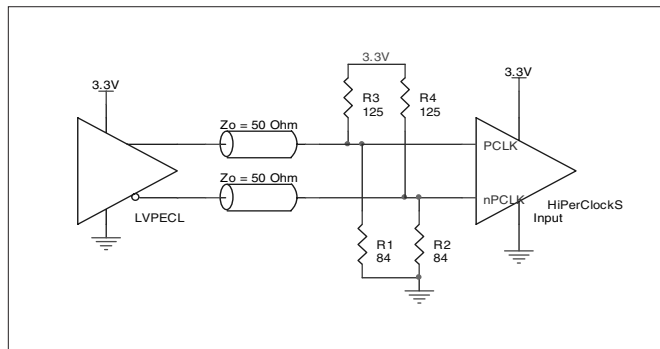

FIGURE 4C. HiPerClockS PCLK/nPCLK INPUT DRIVEN BY A 3.3V LVPECL DRIVER

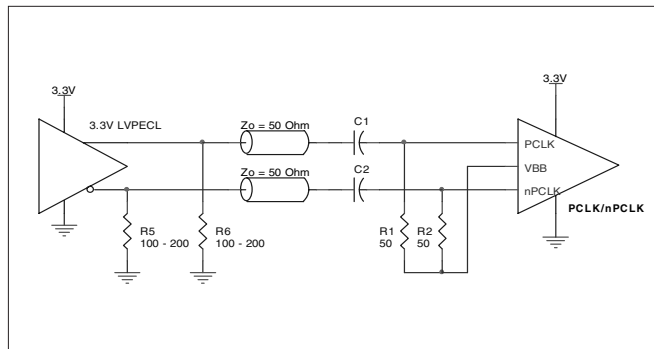

FIGURE 4D. HiPerClockS PCLK/nPCLK INPUT DRIVEN BY A 3.3V LVPECL DRIVER WITH AC COUPLE

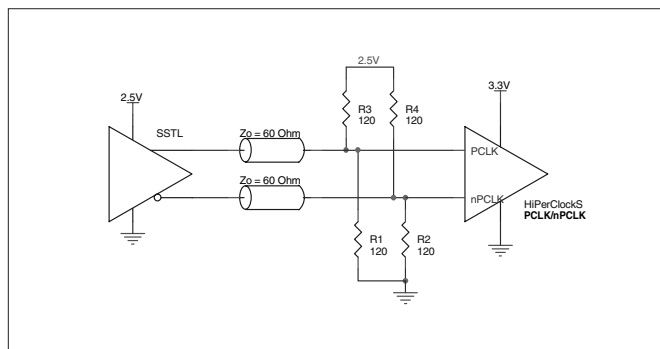

FIGURE 4E. HiPerClockS PCLK/nPCLK INPUT DRIVEN BY AN SSTL DRIVER

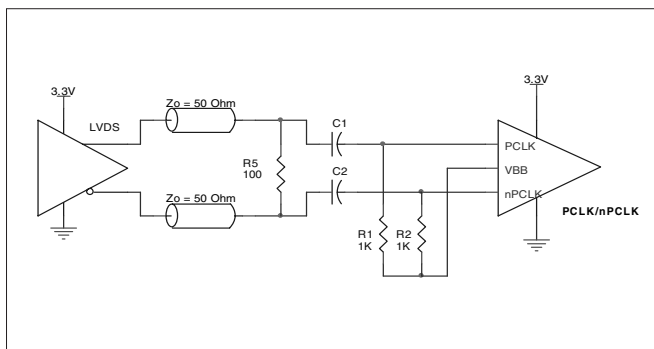
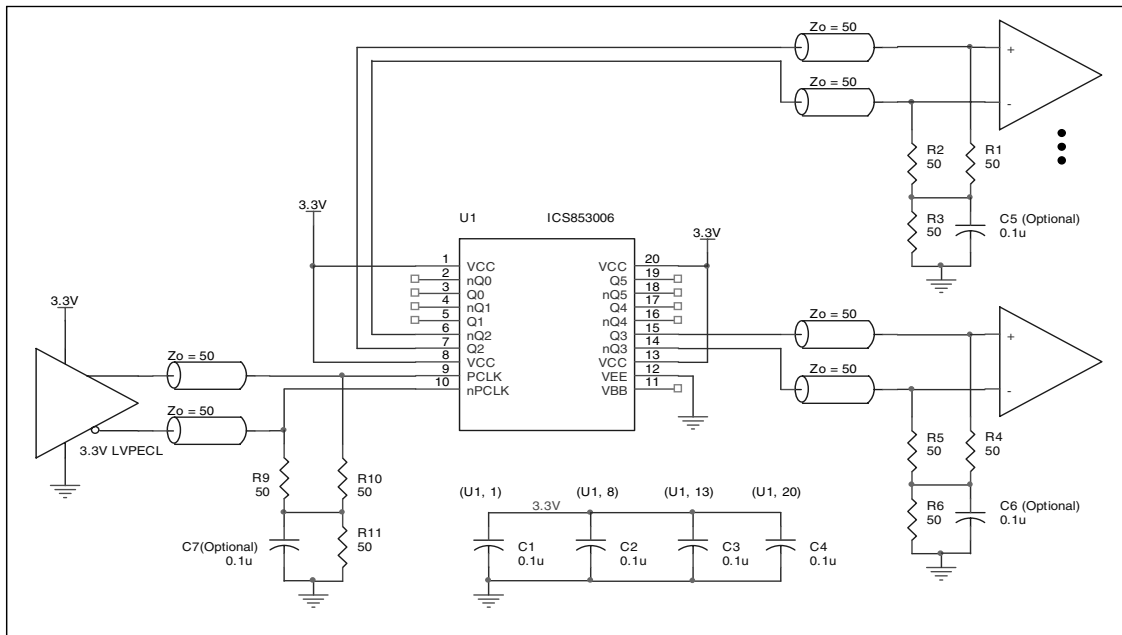

FIGURE 4F. HiPerClockS PCLK/nPCLK INPUT DRIVEN BY A 3.3V LVDS DRIVER

**SCHEMATIC EXAMPLE**

Figure 5 shows a schematic example of ICS853006. The ICS853006 input can accept various types of differential input signal. In this example, the inputs are driven by an LVPECL drivers. For the ICS853006 LVPECL output driver, an example of LVPECL driver termination approach is shown in this schematic.

Additional LVPECL driver termination approaches are shown in the LVPECL Termination Application Note. It is recommended at least one decoupling capacitor per power pin. The decoupling capacitors should be physically located near the power pins. For ICS853006, the unused output can be left floating.



**FIGURE 5. ICS853006 LVPECL CLOCK OUTPUT BUFFER SCHEMATIC EXAMPLE**

## POWER CONSIDERATIONS

This section provides information on power dissipation and junction temperature for the ICS853006. Equations and example calculations are also provided.

### 1. Power Dissipation.

The total power dissipation for the ICS853006 is the sum of the core power plus the power dissipated in the load(s). The following is the power dissipation for  $V_{CC} = 3.465V$ , which gives worst case results.

**NOTE:** Please refer to Section 3 for details on calculating power dissipated in the load.

- Power (core)<sub>MAX</sub> =  $V_{CC\_MAX} * I_{EE\_MAX} = 3.465V * 115mA = 398.48mW$
- Power (outputs)<sub>MAX</sub> = **30.94mW/Loaded Output pair**  
If all outputs are loaded, the total power is  $6 * 30.94mW = 185.64mW$

$$\text{Total Power}_{\_MAX} (3.465V, \text{ with all outputs switching}) = 398.48mW + 185.64mW = 584.12mW$$

### 2. Junction Temperature.

Junction temperature,  $T_j$ , is the temperature at the junction of the bond wire and bond pad and directly affects the reliability of the device. The maximum recommended junction temperature for HiPerClockS™ devices is 125°C.

The equation for  $T_j$  is as follows:  $T_j = \theta_{JA} * Pd\_total + T_A$

$T_j$  = Junction Temperature

$\theta_{JA}$  = Junction-to-Ambient Thermal Resistance

$Pd\_total$  = Total Device Power Dissipation (example calculation is in section 1 above)

$T_A$  = Ambient Temperature

In order to calculate junction temperature, the appropriate junction-to-ambient thermal resistance  $\theta_{JA}$  must be used. Assuming a moderate air flow of 200 linear feet per minute and a multi-layer board, the appropriate value is 66.6°C/W per Table 6 below.

Therefore,  $T_j$  for an ambient temperature of 85°C with all outputs switching is:

$$85^\circ C + 0.584W * 66.6^\circ C/W = 123.9^\circ C. \text{ This is below the limit of } 125^\circ C$$

This calculation is only an example.  $T_j$  will obviously vary depending on the number of loaded outputs, supply voltage, air flow, and the type of board (single layer or multi-layer).

**TABLE 6. THERMAL RESISTANCE  $\theta_{JA}$  FOR 20-PIN TSSOP, FORCED CONVECTION**

$\theta_{JA}$ by Velocity (Linear Feet per Minute)			
	0	200	500
Single-Layer PCB, JEDEC Standard Test Boards	114.5°C/W	98.0°C/W	88.0°C/W
Multi-Layer PCB, JEDEC Standard Test Boards	73.2°C/W	66.6°C/W	63.5°C/W

**NOTE:** Most modern PCB designs use multi-layered boards. The data in the second row pertains to most designs.

### 3. Calculations and Equations.

LVPECL output driver circuit and termination are shown in Figure 6.

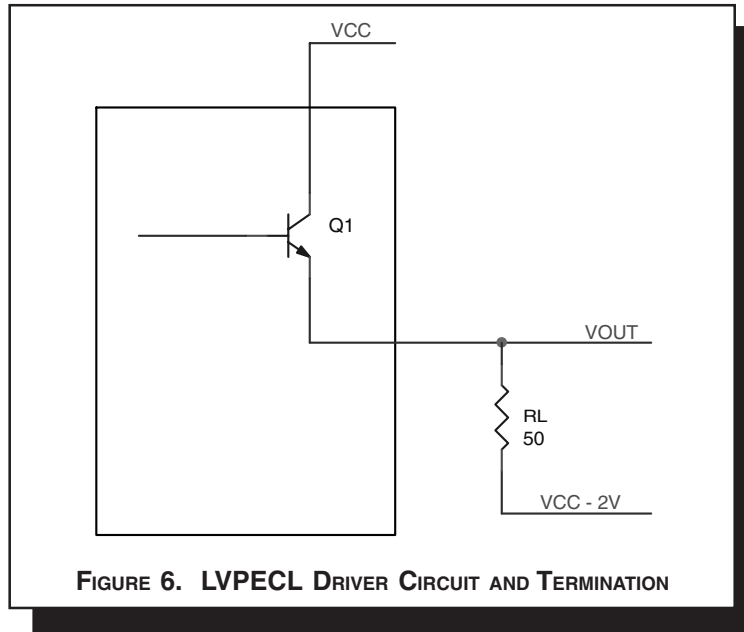

To calculate worst case power dissipation into the load, use the following equations which assume a 50Ω load, and a termination voltage of  $V_{CC} - 2V$ .

- For logic high,  $V_{OUT} = V_{OH\_MAX} = V_{CC\_MAX} - 0.935V$

$$(V_{CC\_MAX} - V_{OH\_MAX}) = 0.935V$$

- For logic low,  $V_{OUT} = V_{OL\_MAX} = V_{CC\_MAX} - 1.67V$

$$(V_{CC\_MAX} - V_{OL\_MAX}) = 1.67V$$

$Pd\_H$  is power dissipation when the output drives high.

$Pd\_L$  is the power dissipation when the output drives low.

$$Pd\_H = [(V_{OH\_MAX} - (V_{CC\_MAX} - 2V))/R_L] * (V_{CC\_MAX} - V_{OH\_MAX}) = [(2V - (V_{CC\_MAX} - V_{OH\_MAX}))/R_L] * (V_{CC\_MAX} - V_{OH\_MAX}) = [(2V - 0.935V)/50\Omega] * 0.935V = 19.92mW$$

$$Pd\_L = [(V_{OL\_MAX} - (V_{CC\_MAX} - 2V))/R_L] * (V_{CC\_MAX} - V_{OL\_MAX}) = [(2V - (V_{CC\_MAX} - V_{OL\_MAX}))/R_L] * (V_{CC\_MAX} - V_{OL\_MAX}) = [(2V - 1.67V)/50\Omega] * 1.67V = 11.02mW$$

Total Power Dissipation per output pair =  $Pd\_H + Pd\_L = 30.94mW$

## RELIABILITY INFORMATION

TABLE 7.  $\theta_{JA}$  VS. AIR FLOW TABLE FOR 20 LEAD TSSOP

$\theta_{JA}$ by Velocity (Linear Feet per Minute)			
	0	200	500
Single-Layer PCB, JEDEC Standard Test Boards	114.5°C/W	98.0°C/W	88.0°C/W
Multi-Layer PCB, JEDEC Standard Test Boards	73.2°C/W	66.6°C/W	63.5°C/W

**NOTE:** Most modern PCB designs use multi-layered boards. The data in the second row pertains to most designs.

### TRANSISTOR COUNT

The transistor count for ICS853006 is: 1340

## PACKAGE OUTLINE - G SUFFIX FOR 20 LEAD TSSOP

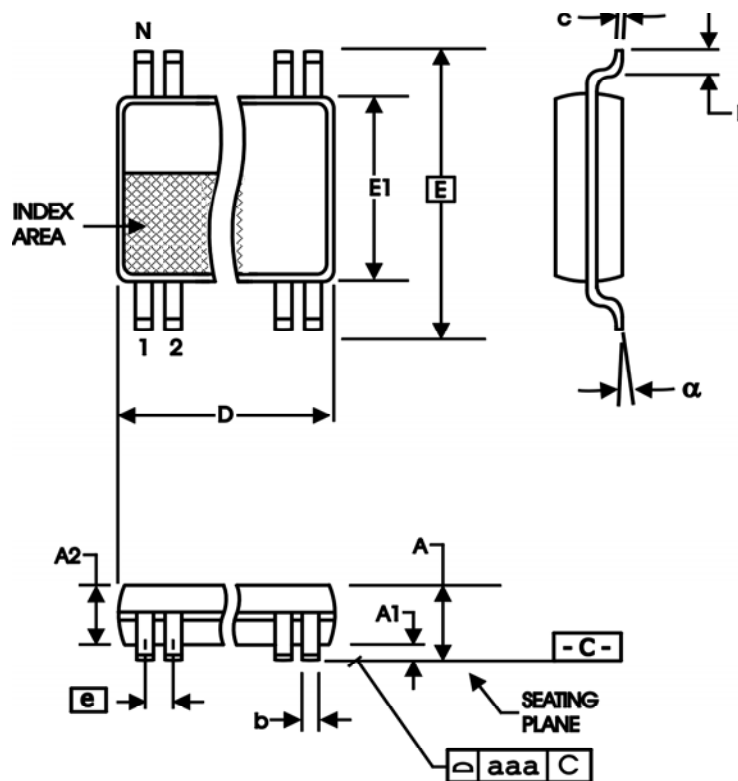

TABLE 8. PACKAGE DIMENSIONS

SYMBOL	Millimeters	
	Minimum	Maximum
N	20	
A	--	1.20
A1	0.05	0.15
A2	0.80	1.05
b	0.19	0.30
c	0.09	0.20
D	6.40	6.60
E	6.40 BASIC	
E1	4.30	4.50
e	0.65 BASIC	
L	0.45	0.75
$\alpha$	0°	8°
aaa	--	0.10

Reference Document: JEDEC Publication 95, MO-153

TABLE 8. ORDERING INFORMATION

Part/Order Number	Marking	Package	Count	Temperature
ICS853006AG	ICS853006AG	20 Lead TSSOP	72 per tube	-40°C to 85°C
ICS853006AGT	ICS853006AG	20 Lead TSSOP on Tape and Reel	2500	-40°C to 85°C
ICS853006AGLF	ICS853006AGL	20 Lead "Lead-Free" TSSOP	72 per tube	-40°C to 85°C
ICS853006AGLFT	ICS853006AGL	20 Lead "Lead-Free" TSSOP on Tape and Reel	2500	-40°C to 85°C

The aforementioned trademark, HiPerClockS™ is a trademark of Integrated Circuit Systems, Inc. or its subsidiaries in the United States and/or other countries. While the information presented herein has been checked for both accuracy and reliability, Integrated Circuit Systems, Incorporated (ICS) assumes no responsibility for either its use or for infringement of any patents or other rights of third parties, which would result from its use. No other circuits, patents, or licenses are implied. This product is intended for use in normal commercial and industrial applications. Any other applications such as those requiring high reliability or other extraordinary environmental requirements are not recommended without additional processing by ICS. ICS reserves the right to change any circuitry or specifications without notice. ICS does not authorize or warrant any ICS product for use in life support devices or critical medical instruments.

REVISION HISTORY SHEET				
Rev	Table	Page	Description of Change	Date
A	T8	1 16	Added Lead-Free bullet to Features section. Added Lead-Free P/N to Ordering Information table.	11/9/04

Innovate with IDT and accelerate your future networks. Contact:

**www.IDT.com**

**For Sales**

800-345-7015  
408-284-8200  
Fax: 408-284-2775

**For Tech Support**

clockhelp@idt.com  
408-284-8200

---

**Corporate Headquarters**

Integrated Device Technology, Inc.  
6024 Silver Creek Valley Road  
San Jose, CA 95138  
United States  
800 345 7015  
+408 284 8200 (outside U.S.)

**Asia Pacific and Japan**

Integrated Device Technology  
Singapore (1997) Pte. Ltd.  
Reg. No. 199707558G  
435 Orchard Road  
#20-03 Wisma Atria  
Singapore 238877  
+65 6 887 5505

**Europe**

IDT Europe, Limited  
Prime House  
Barnett Wood Lane  
Leatherhead, Surrey  
United Kingdom KT22 7DE  
+44 1372 363 339



www.IDT.com

## Looking for pricing, stock, or lifecycle information?

Click below to explore more details on WIN SOURCE:

- ⊖ [View ICS853006AGLFT on WIN SOURCE](#)
- ⊖ [IDT, Integrated Device Technology Inc Information](#)

## Optimize Your Supply Chain with WIN SOURCE Solutions

- ✓ Global Sourcing Solution
- ✓ Obsolete Management
- ✓ Cost Control Management
- ✓ Shortage Management
- ✓ Alternative Solution
- ✓ Excess Inventory Management