



**THE DATASHEET OF  
78M6613-EVM-1**



# **78M6613 Evaluation Board User Manual**



*Maxim cannot assume responsibility for use of any circuitry other than circuitry entirely embodied in a Maxim product. No circuit patent licenses are implied. Maxim reserves the right to change the circuitry and specifications without notice at any time. The parametric values (min and max limits) shown in the Electrical Characteristics table are guaranteed. Other parametric values quoted in this data sheet are provided for guidance.*

**Maxim Integrated 160 Rio Robles, San Jose, CA 95134 USA 1-408-601-1000**

© 2011 Maxim Integrated

The Maxim logo and Maxim Integrated are trademarks of Maxim Integrated Products, Inc.

## Table of Contents

<b>1</b>	<b>Introduction .....</b>	<b>5</b>
1.1	Package Contents .....	5
1.2	System Requirements.....	5
1.3	Safety and ESD Notes .....	6
1.4	Firmware Demo Code Introduction.....	6
1.5	Testing the 78M6613 Evaluation Board Prior to Shipping .....	6
<b>2</b>	<b>Installation .....</b>	<b>7</b>
2.1	USB Driver Installation.....	7
2.2	Confirm COM Port Mapping .....	8
2.3	Basic Connection Setup.....	9
2.4	Verify Serial Connection to the PC.....	11
2.5	In-Circuit Emulator (ICE) Adaptor.....	13
<b>3</b>	<b>Schematics, Bill of Materials and PCB Layouts .....</b>	<b>14</b>
3.1	78M6613 Evaluation Board Schematics.....	14
3.2	78M6613 Evaluation Board Bill of Materials .....	16
3.3	78M6613 Evaluation Board PCB Layouts.....	18
<b>4</b>	<b>Ordering Information.....</b>	<b>19</b>
<b>5</b>	<b>Contact Information.....</b>	<b>19</b>
	<b>Revision History .....</b>	<b>20</b>

## Figures

Figure 1: 78M6613 Evaluation Board Connections.....	9
Figure 2: 78M6613 Evaluation Board Application Diagram.....	10
Figure 3: ICE Adaptor.....	13
Figure 4: Attaching the ICE Adaptor.....	13
Figure 5: 78M6613 Evaluation Board Electrical Schematic (1 of 2).....	14
Figure 6: 78M6613 Evaluation Board Electrical Schematic (2 of 2).....	15
Figure 7: 78M6613 Evaluation Board PCB Top View.....	18
Figure 8: 78M6613 Evaluation Board PCB Bottom View.....	18

## Table

Table 1: COM Port Setup Parameters.....	11
Table 2: 78M6613 Evaluation Board Bill of Materials.....	16

# 1 Introduction

The Teridian™ 78M6613 Evaluation Board is an electrical measurement unit for performing measurements of up to two single-phase AC loads. It incorporates the 78M6613 power- and energy-measurement IC and connects to a PC through a USB cable such as the one provided in the demo kit. The Evaluation Board demonstrates the capability of the 78M6613 energy-meter controller chip for measurement accuracy and overall system use.

The board is preprogrammed with Firmware Demo Code (file name 6613\_OMU\_S2+2\_URT\_V1\_1x.hex) in the flash memory of the 78M6613 IC that allows evaluation of the IC's capabilities.

The 78M6613 energy-measurement data and status is read back over the serial UART interface using a text-based command line interface (CLI) command set. Easy manual operation is performed using HyperTerminal. Refer to the applicable 6613\_OMU\_S2+2\_URT\_V1\_1x *Firmware Description Document* for invocation usage of the CLI commands.

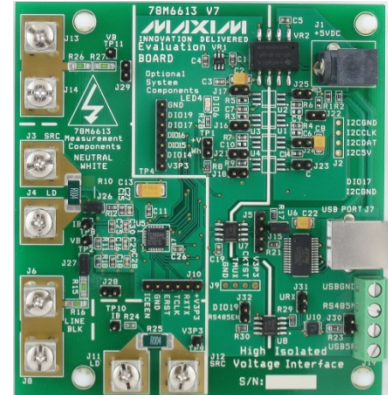

## 1.1 Package Contents

The 78M6613 Evaluation Board Demo Kit includes:

- 78M6613 Evaluation Board
- USB Cable Assembly USB A-B 28/24 1.8M (Tyco/Amp 1487588-3)
- CD with documentation

## 1.2 System Requirements

The 78M6613 Evaluation Board requires use of a PC with the following features:

- PC (1 GHz, 1 GB) with Microsoft Windows XP®, Windows Vista®, or Windows 7 operating systems equipped with USB port
- Minimum 1024 x 768 video display resolution

### 1.3 Safety and ESD Notes



**EXERCISE CAUTION WHEN LIVE AC VOLTAGES ARE PRESENT!**



Standard ESD precautions must be taken when handling electronic equipment. The 78M6613 contains ESD protected interfaces.

Do not connect test equipment, ICE emulators or external development boards directly to the 78M6613 hardware. Damage to the 78M6613 and external equipment will occur due to the 78M6613's "high side" reference topology. The 78M6613's V3P3 (i.e., "high side") is connected directly to Neutral (Earth Ground) creating a ground reference disparity with any properly grounded external equipment.

The board components and firmware settings are designed to operate with the following nominal AC electrical ranges:

Voltage	Current	Line Frequency
110-240 VAC	10 mA – 20A	46-64 Hz

### 1.4 Firmware Demo Code Introduction

The Firmware Demo Code provides the following features:

- Basic energy measurement data such as Watts, Volts, current, VAR, VA, phase angle, power factor, accumulated energy, frequency, date/time, and various alarm statuses.
- Control of alarm thresholds, calibration coefficients, temperature compensation, etc.

The following setup is used to facilitate performance evaluation between the user at the PC host and the firmware code in the board:

- The CLI through HyperTerminal or comparable terminal emulator on a different operating system. For information about the CLI, see the applicable Firmware Description Document.

The 78M6613 is shipped with Firmware Demo Code Revision 1.0 or later loaded in the 78M6613 chip and included on the CD. The code revision can be verified by entering the command `>i` via the command line interface. Firmware for the Demo Unit can be updated using either the Teridian TFP2 or an in-circuit emulator such as the Signum Systems ADM51 ([www.signum.com](http://www.signum.com)).

### 1.5 Testing the 78M6613 Evaluation Board Prior to Shipping

Before every 78M6613 Evaluation Board is shipped, the following procedures have been performed at the factory:

- Full Calibration – Precise energy source equipment is used to calibrate the current and voltage. The temperature is also calibrated at the same time.
- Accuracy Test – This "bench" level test ensures the energy accuracy is within  $\pm 0.5\%$ .

## 2 Installation

### 2.1 USB Driver Installation

This evaluation kit includes an isolated USB interface for serial communications with a PC. The FTDI USB controller IC FT232R performs the USB functions. The FTDI driver for Windows presents a virtual COM port for enabling serial communications. Control of the 78M6613 Evaluation Board can be managed using a terminal emulation program. The FTDI Windows driver is a certified driver for Windows 2000 and Windows XP.

1. Upon attaching the 78M6613 Evaluation Board to the PC, the Found New Hardware Wizard automatically launches and installs the appropriate driver files. If your PC does not find the FTDI driver files on its local hard disk drive, locate and reference the FTDI USB Driver and Utilities subdirectory on the CD. The FT232R controller is powered from the USB cable and is active even when no AC power is applied to the 78M6613 Evaluation Board.

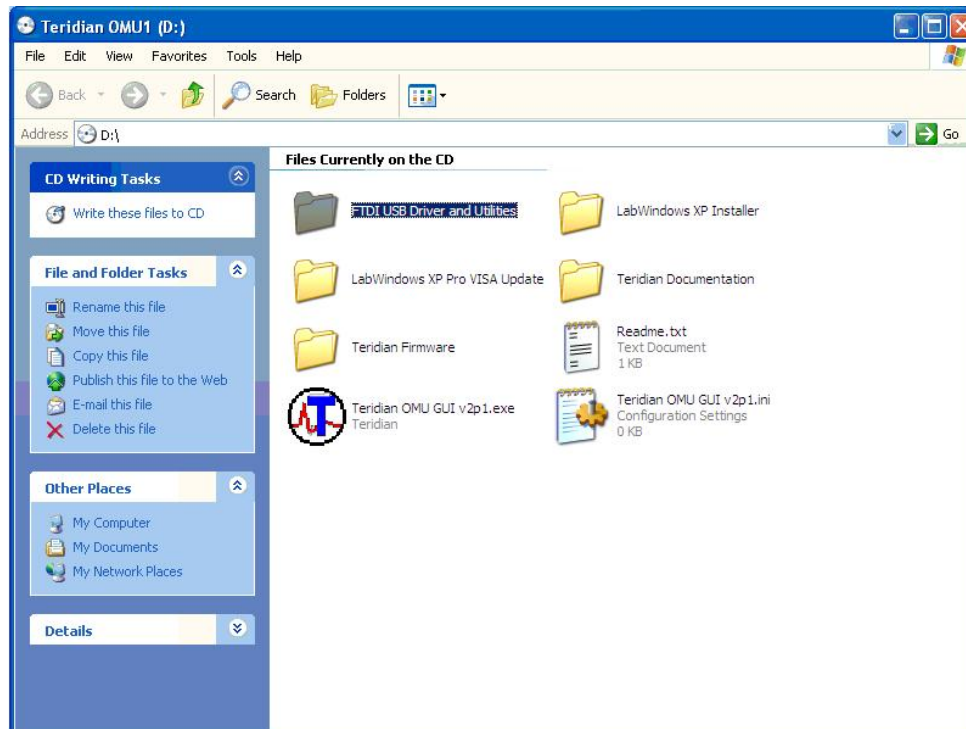

Note: If an older FTDI driver has been previously installed, it is recommended to remove the older version before installing this newer FTDI driver. Execute the **ftdiClean.exe** utility from the FTDI USB Driver and Utilities subdirectory.

For FTDI driver support on other operating systems, refer to FTDI's website at ([www.ftdichip.com/FTDrivers.htm](http://www.ftdichip.com/FTDrivers.htm)).

## 2.2 Confirm COM Port Mapping

1. Launch the **Control Panel** and click on the **System** icon.

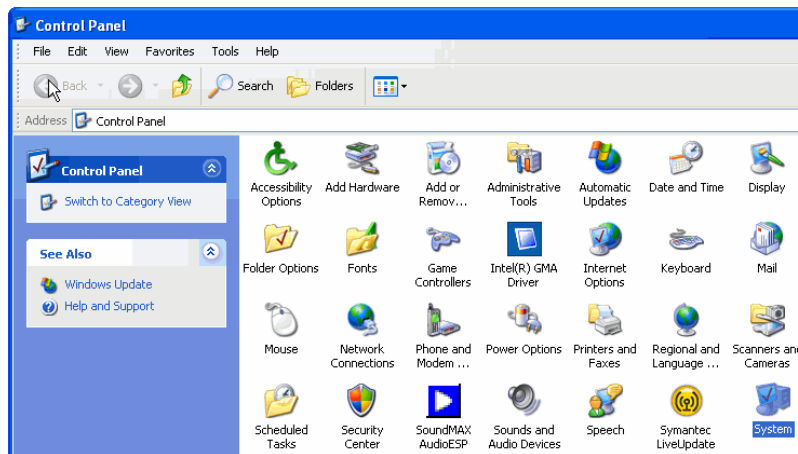

2. The **System Properties** screen appears. Click on the **Hardware** tab. Click on **Device Manager**. Under **Ports (COM & LPT)**, look for the **USB Serial Port** assignment.

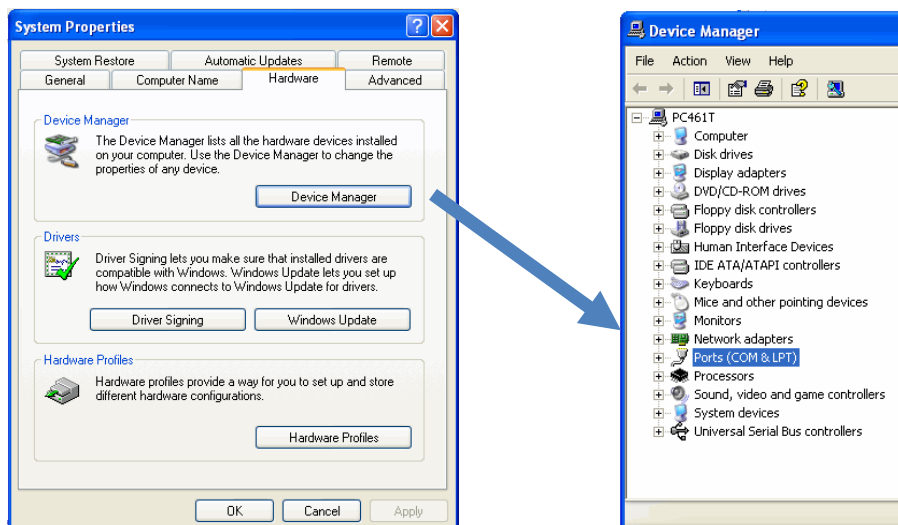

3. Take note of the COM port assignment for the USB Serial Port.

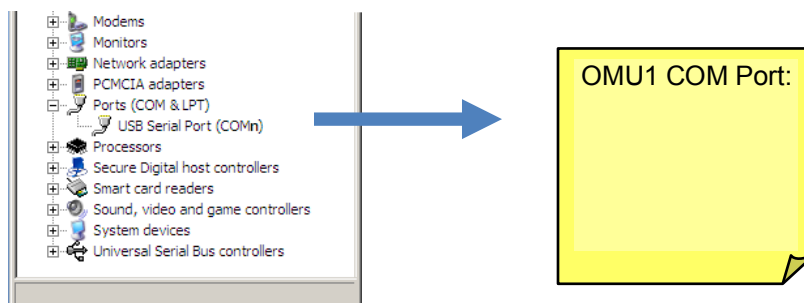

## 2.3 Basic Connection Setup

Figure 1 shows the basic connections of the 78M6613 Evaluation Board for use with external equipment. The 78M6613 Evaluation Board is powered through the USB cable. This same USB cable provides the communications link between the host PC and the 78M6613 Evaluation Board.

The 78M6613 Evaluation Board accepts 120 VAC and 230 VAC (nominal) up to 300 VAC (max).

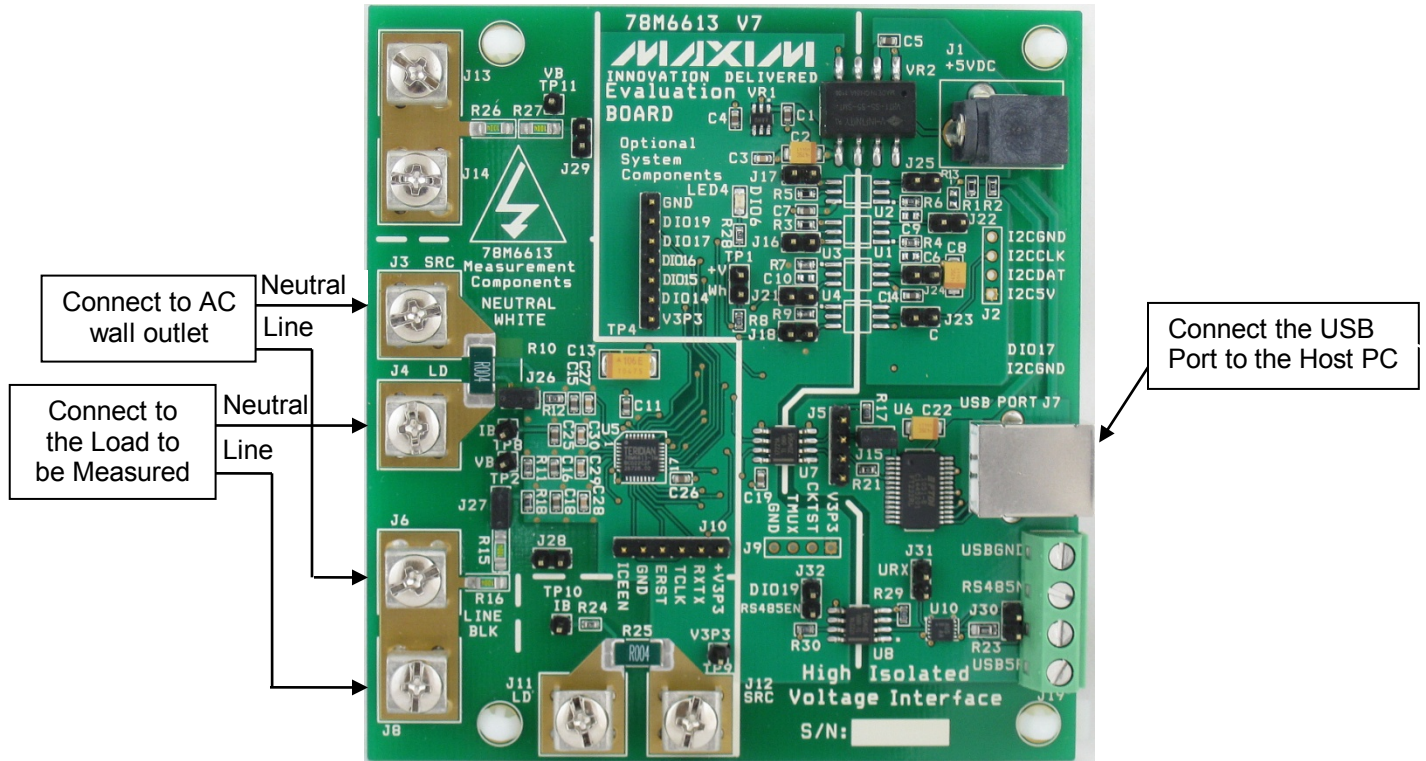

**Figure 1: 78M6613 Evaluation Board Connections**

Attach an AC source to J3 (Neutral) and J6 (Line). Attach the AC load to J4 (Neutral) and J8 (Line).

Note: The hardware and embedded firmware are capable of measuring two outlets or AC loads. For more information, contact Maxim application support.

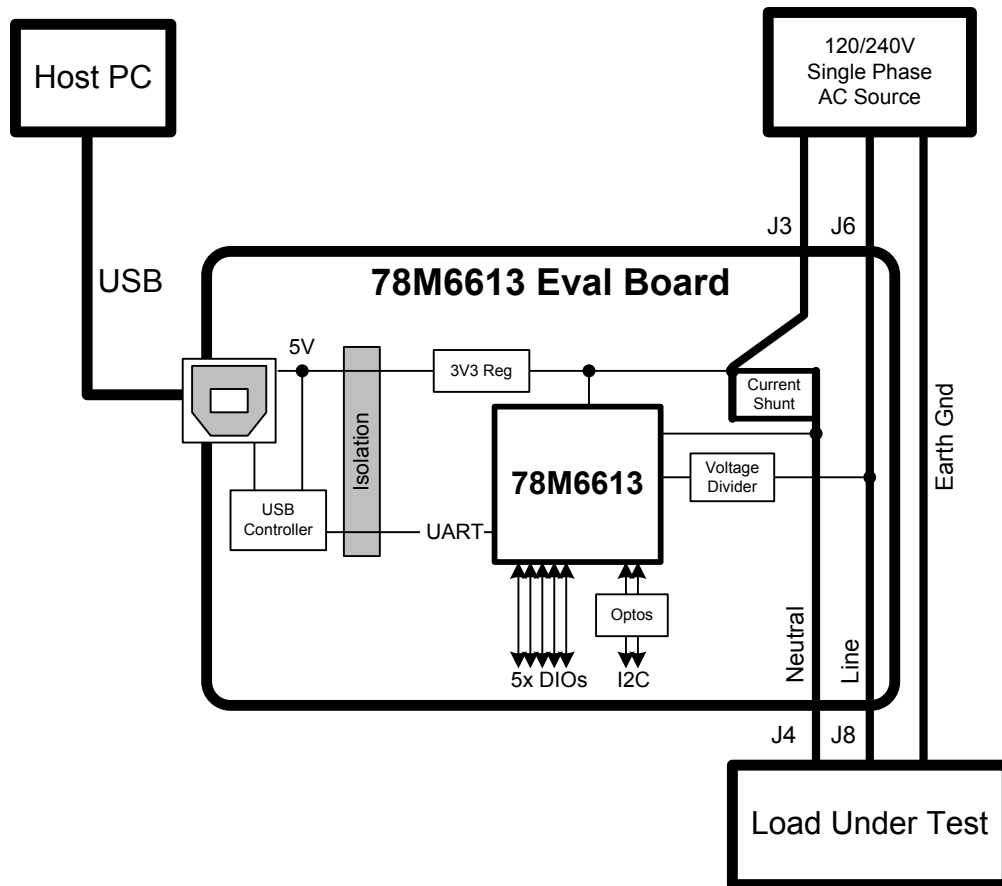

Figure 2: 78M6613 Evaluation Board Application Diagram

## 2.4 Verify Serial Connection to the PC

After connecting the USB cable from the 78M6613 Evaluation Board to the host PC, start the HyperTerminal application (or another suitable communication program) and create a session using the communication parameters shown in Table 1.

**Table 1: COM Port Setup Parameters**

Setup Parameter	Value
Port speed (baud)	38400
Data bits	8
Parity	None
Stop bits	1
Flow control	None

HyperTerminal can be found in Windows by selecting **Start** → **All Programs** → **Accessories** → **Communications** → **HyperTerminal**. The connection parameters are configured by selecting **File** → **Properties**. The **New Connection Properties** menu appears.

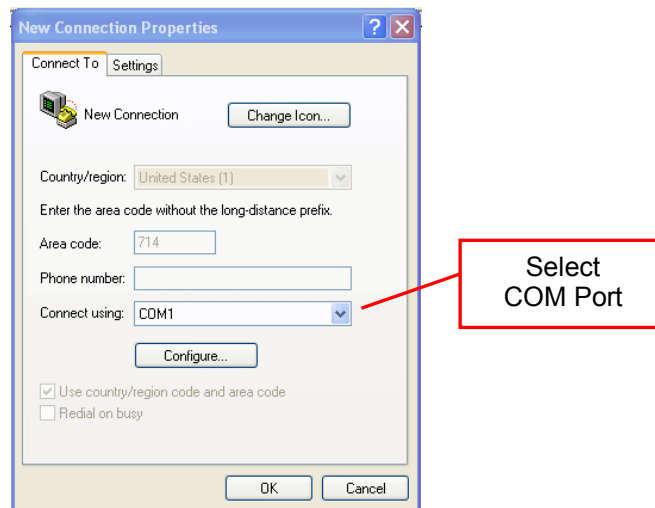

Select the appropriate COM port and click **Configure**. The **COMn Properties** menu appears.

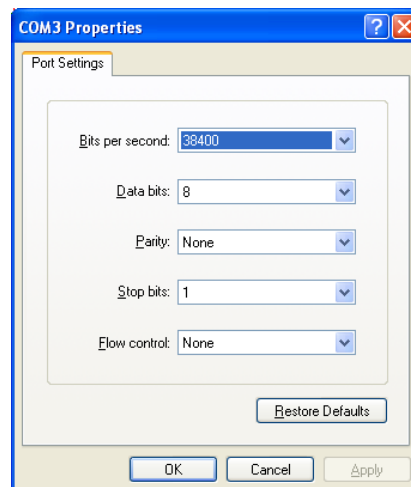

Note that port parameters can only be adjusted when the connection is not active. It may be necessary to click the Disconnect Button to disconnect the port.

### **FTDI COM Port Trouble-Shooting**

If the FTDI device driver did not install properly, there would be no assigned COM port number for the FTDI controller. Repeat the USB Driver Installation, see Section 2.1.

Microsoft Windows may associate a Ball Point device to the FTDI USB controller. When this occurs a FTDI device COM port assignment is available via HyperTerminal but there is no communications data. Verify if a Ball Point device has been added to the "Human Interface Devices" via the Device manager. Refer to Section 2.2 for access to the Device Manager. If a Ball Point device exists, delete it and unplug and replug the evaluation board's USB cable.

CLI measurement can be displayed in two different formats: decimal or hex. Both formats are returned as ASCII character strings. The following figure uses CLI commands to return the same data presented in the Auto-Reporting mode.

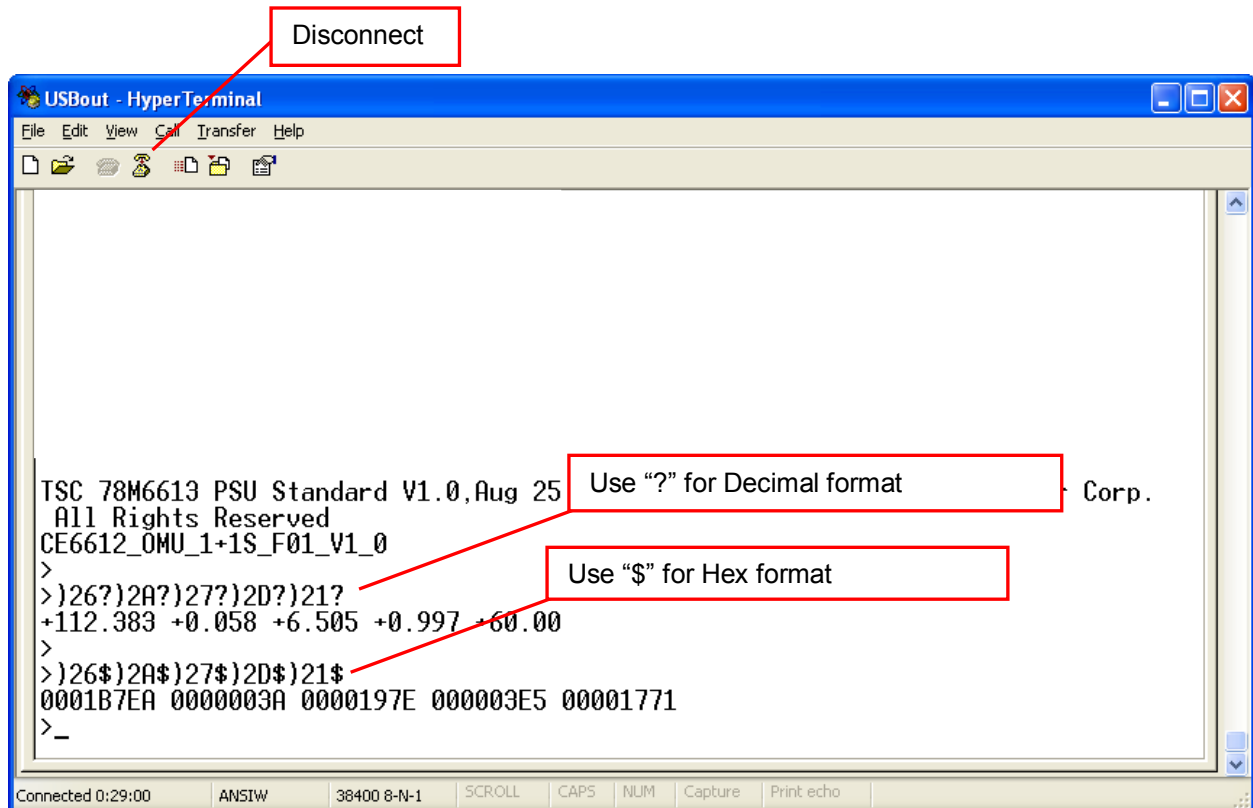

Refer to the applicable Firmware Description Document for a complete description of available CLI commands and their invocation usage.

The 6613\_OMU\_S2+2\_URT\_V1\_1x.hex is compatible with the 78M6612 OMU GUI. Refer to the *OMU1-S-WW Demo Unit User Manual* for installation and operation instructions applicable to the OMU GUI.

## 2.5 In-Circuit Emulator (ICE) Adaptor

The 78M6613 firmware (stored in internal flash memory) can be updated to accommodate program enhancements. Use the Signum ADM51 or the Teridian TFP-2 to download new firmware to the 78M6613. The supplied ICE Adaptor is required to interface the flat ribbon cable (provided with the ADM51 or TFP-2) to the 78M6613 Evaluation Board.

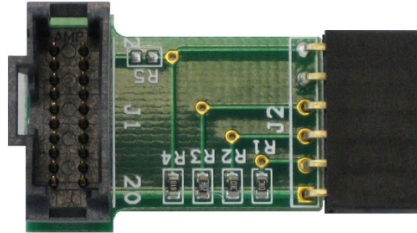

Figure 3: ICE Adaptor

Figure 4 shows how to attach the ICE Adaptor to the 78M6613 Evaluation Board. Please make note of the orientation of the ICE Adaptor as to how it attaches to the 78M6613 Evaluation Board (V3P3 ICE Adaptor pin connects to the +V3P3 Evaluation Board pin).

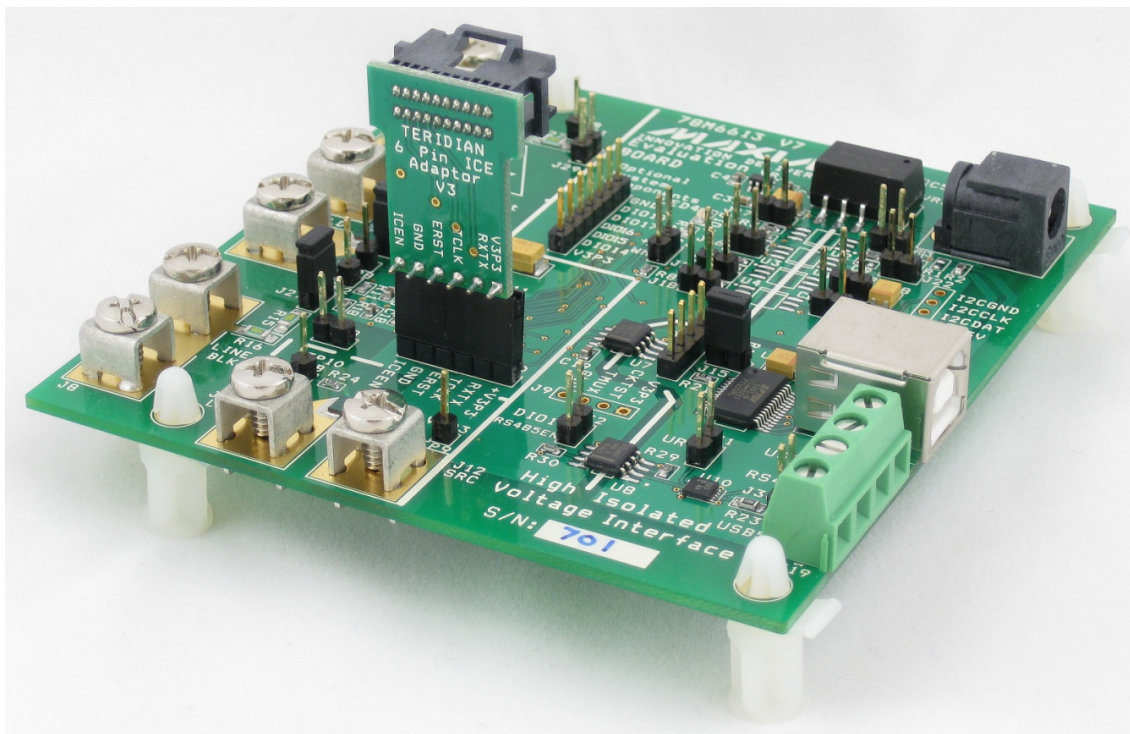

Figure 4: Attaching the ICE Adaptor

Disconnect the 78M6613 Evaluation Board from live AC voltages before connecting the ADM51 or TFP-2. An Earth ground disparity and high AC voltages are present on the 78M6613 Evaluation Board when it is connected to the AC outlet. Equipment damage to the 78M6613, ADM51/TFP-2 and attached PC may occur when live AC voltages are present on the 78M6613 Evaluation Board. Refer to the *78M6613 Safety Precautions Applications Note* for additional information.



It is recommended to always use the supplied flat ribbon cable. Do not use discrete wires in place of the flat ribbon. Poor signal integrity will cause flash memory programming errors. Additional adaptors and flat ribbon cables can be ordered through Maxim.

Power to the 78M6613 is provided via the USB cable. Attach the USB cable during programming.

### 3 Schematics, Bill of Materials and PCB Layouts

This section includes the schematics, bill of materials and PCB layouts for the 78M6613 Evaluation Board.

#### 3.1 78M6613 Evaluation Board Schematics

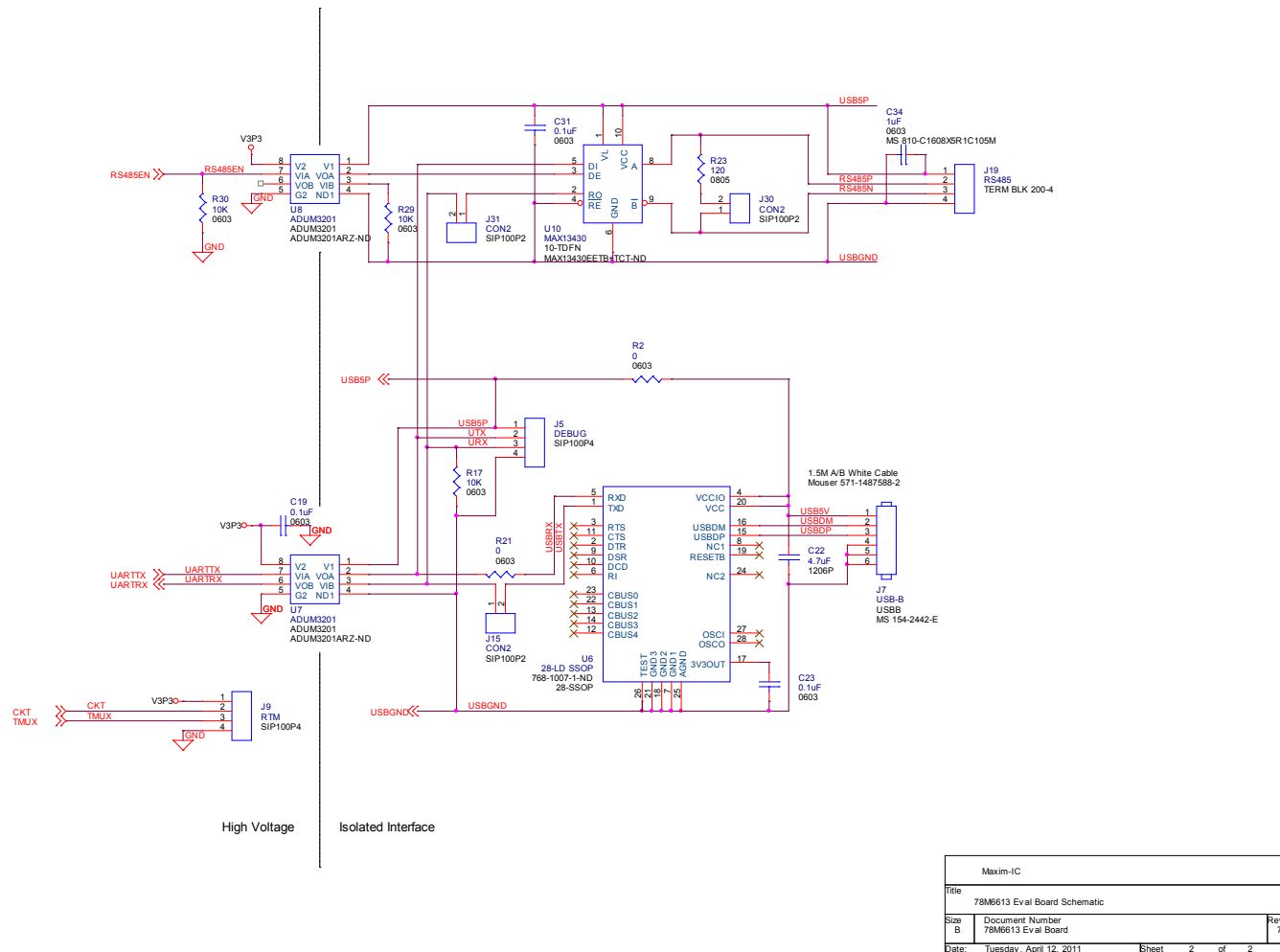

Figure 5: 78M6613 Evaluation Board Electrical Schematic (1 of 2)

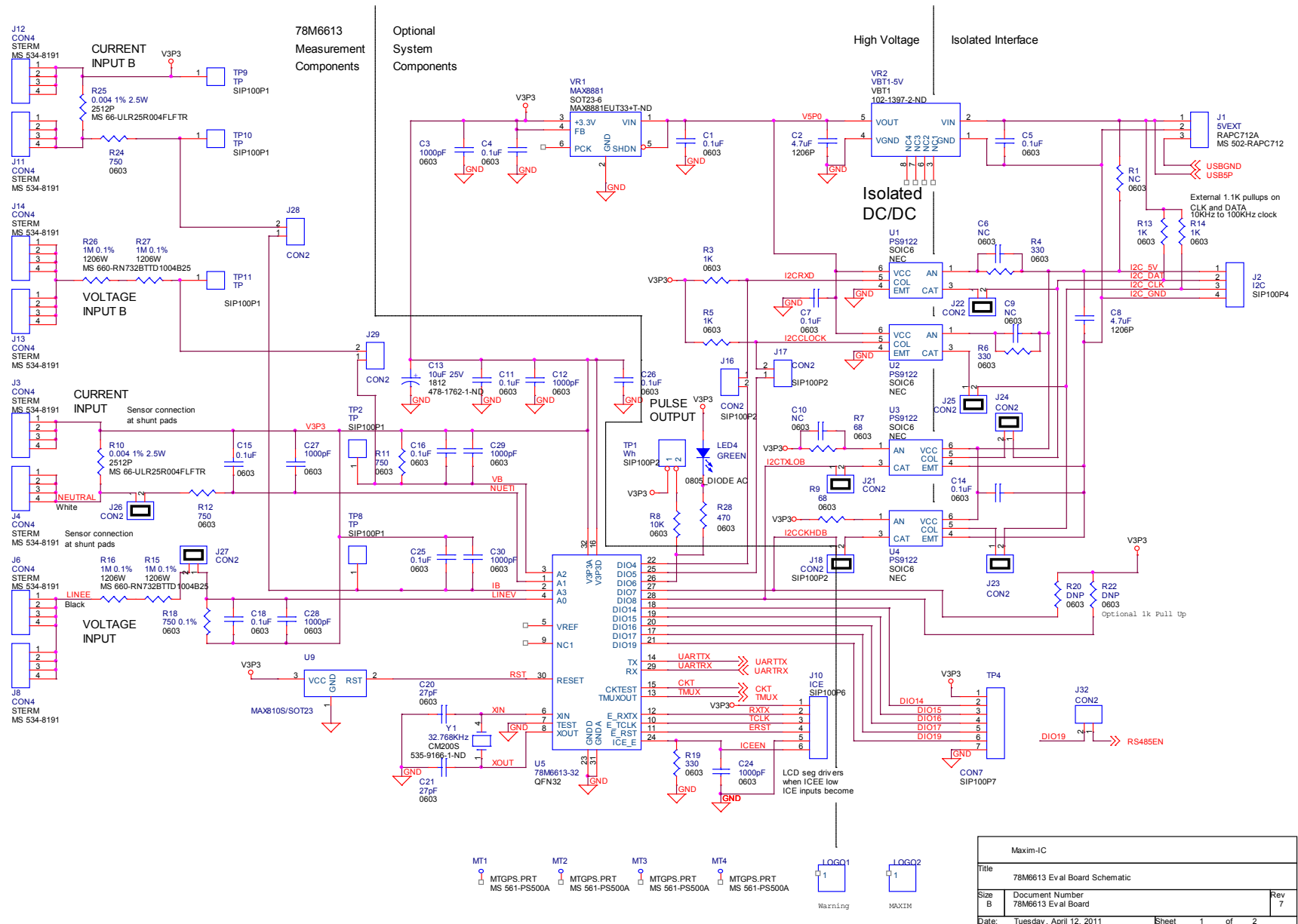

Figure 6: 78M6613 Evaluation Board Electrical Schematic (2 of 2)

### 3.2 78M6613 Evaluation Board Bill of Materials

Table 2: 78M6613 Evaluation Board Bill of Materials

Item	Qty	Reference	Part	Footprint	Digi-Key (MS : Mouser)	Part Number	Manufacture	ROHS
1	14	C1,C4,C5,C7,C11,C14, C15,C16,C18,C19,C23,C 25,C26, C31	0.1uF	0603	587-1243-1-ND	UMK107B7104KA-T	Taiyo Yuden	x
2	3	C2,C8,C22	4.7uF	1210	MS 478-2396-1-ND	TPSB475K016R1500	AVX	x
3	7	C3,C12,C24,C27,C28,C2 9,C30	1000pF	0603	445-1298-1-ND	C1608X7R2A102K	TDK	x
4	3	C6,C9,C10	DNP	0603	-	-	-	-
5	1	C13	10uF 25V	2312	478-1762-1-ND	TPSC106K025R0500	AVX	x
6	2	C20,C21	27pF	0603	311-1063-1-ND	CC0603JRNP09BN270	Yageo	x
7	1	C34	1uF	0603	MS 810-C1608X5R1C105K	C1608X5R1C105K	TDK	x
8	1	J1	5VEXT	RAPC712A	MS 502-RAPC712X	RAPC712X	Switchcraft	x
9	1	J2	DNP	SIP100P4	-	-	-	-
10	8	J3,J4,J6,J8,J11,J12,J13, J14	CON4	STERM	MS 534-8191	8191	Keystone Electronics	x
11	1	J5	DEBUG	SIP100P4	S1011E-36-ND	PBC36SAAN	Sullins Connector Solutions	x
12	1	J7	USB-B	USBB	MS 154-2442-E	154-2442-E	Kobiconn	x
13	1	J9	DNP	SIP100P4	-	-	-	-
14	1	J10	ICE	SIP100P6	S1011E-36-ND	PBC36SAAN	Sullins Connector Solutions	x
15	16	J15,J16,J17,J18,J21,J22, J23,J24,J25,J26,J27,J28, J29,J30,J31,J32	CON2	SIP100P2	S1011E-36-ND	PBC36SAAN	Sullins Connector Solutions	x
16	1	J19	RS485	5.08 mm/4	277-1249-ND	1729144	Phoenix Contact	x
17	1	LED4	GREEN	0805	516-1434-1-ND	HSMG-C170	Avago Technologies US Inc.	x
18	4	MT1,MT2,MT3,MT4,	mount holes	Through hole	MS 561-PS500A	561-PS500A	Eagle Plastic Devices	x

Item	Qty	Reference	Part	Footprint	Digi-Key (MS : Mouser)	Part Number	Manufacture	ROHS
19	5	TP2,TP8,TP9,TP10,TP11	TP/1	SIP100P1	S1011E-36-ND	PBC36SAAN	Sullins Connector Solutions	x
20	2	R2,R21	0	0603	P0.0GCT-ND	ERJ-3GEY0R00V	Panasonic - ECG	x
21	4	R3,R5,R13,R14	1K	0603	P1.00KHCT-ND	ERJ-3EKF1001V	Panasonic - ECG	x
22	3	R4,R6,R19	330	0603	P330GCT-ND	ERJ-3GEYJ331V	Panasonic - ECG	x
23	2	R7,R9	68	0603	P68GCT-ND	ERJ-3GEYJ680V	Panasonic - ECG	x
24	4	R8,R17,R29,R30	10K	0603	311-10KGRCT-ND	RC0603JR-0710KL	Yageo	x
25	2	R10,R25	0.004 1% 2.5W	2512	MS 66-ULR25R004FLFTR	ULR25R004FLFTR	IRC	x
26	3	R11,R12,R24	750	0603	P750GCT-ND	ERJ-3GEYJ751V	Panasonic - ECG	x
27	4	R15,R16,R26,R27	1M 0.1%	1206	MS 660- RN732BTDD1004B25	RN732BTDD1004B25	KOA Speer	x
28	1	R18	750 0.1%	0603	P750YCT-ND	ERA-3YEB751V	Panasonic - ECG	x
29	2	R1,R20,R22	DNP	0603	-	-	-	-
30	1	R23	120	0805	P120CCT-ND	ERJ-6ENF1200V	Panasonic - ECG	x
31	1	R28	470	0603	P470GCT-ND	ERJ-3GEYJ471V	Panasonic - ECG	x
32	1	TP1	Wh	SIP100P2	S1011E-36-ND	PBC36SAAN	Sullins Connector Solutions	x
33	1	TP4	CON7	SIP100P7	S1011E-36-ND	PBC36SAAN	Sullins Connector Solutions	x
34	4	U1,U2,U3,U4	PS9122	SOIC6	DNP	-	-	-
35	1	U5	78M6613-32	QFN32	-	78M6613-IM	Maxim	x
36	1	U6	28-LD SSOP	28-SSOP	768-1007-1-ND	FT232RL-REEL	FTDI	x
37	2	U7,U8	ADUM3201	8-SOIC	ADUM3201ARZ-ND	ADUM3201ARZ	Analog Devices	x
38	1	U9	RESET CIRC	SOT-23-3	MAX810SEUR+TCT-ND	MAX810SEUR+T	Maxim	x
39	1	U10	RS485	10-WDFDN	MAX13430EETB+TCT-ND	MAX13430EETB+T	Maxim	x
40	1	VR1	MAX8881	SOT23-6	MAX8881EUT33+T-ND	MAX8881EUT33+T	Maxim	x
41	1	VR2	VBT1-5V	8-SMD	102-1397-2-ND	VBT1-S5-S5-SMT	CUI Inc.	x
42	1	Y1	32.768KHz	4-SOJ	535-9166-1-ND	ABS25-32.768KHZ-T	Abracon Corporation	x

### 3.3 78M6613 Evaluation Board PCB Layouts

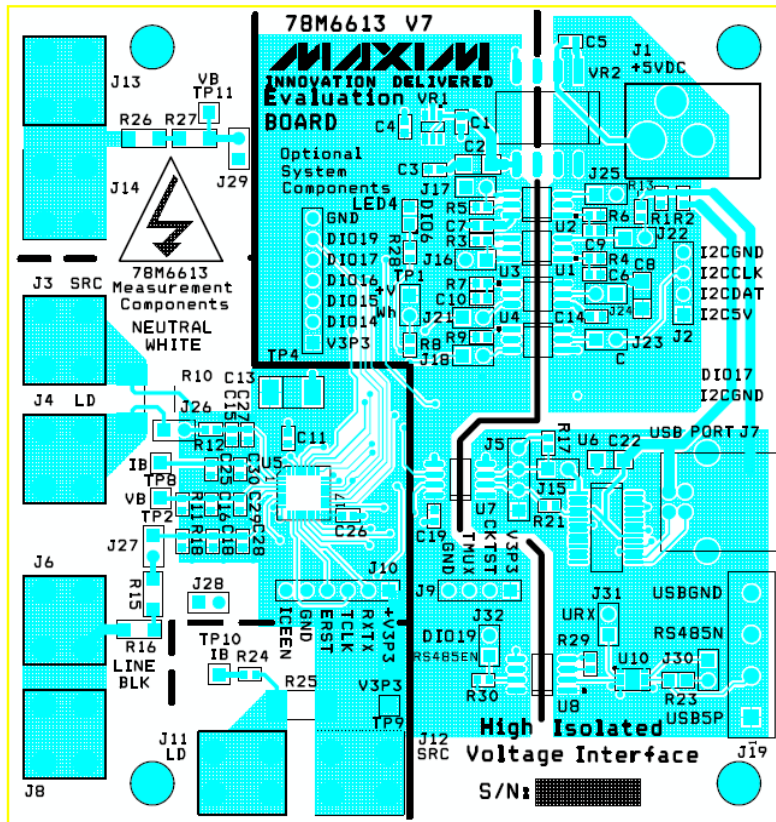

Figure 7: 78M6613 Evaluation Board PCB Top View

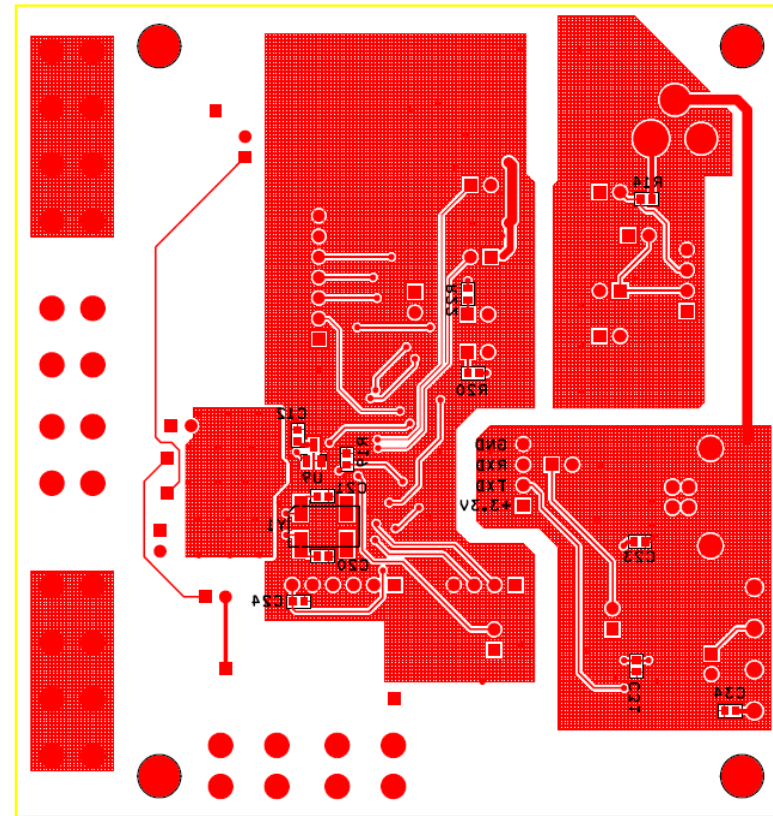

Figure 8: 78M6613 Evaluation Board PCB Bottom View

## 4 Ordering Information

PART	DESCRIPTION
78M6613-EVM-1	78M6613 Evaluation Board

## 5 Contact Information

For more information about Maxim products or to check the availability of the 78M6613, contact technical support at [www.maxim-ic.com/support](http://www.maxim-ic.com/support).

## Revision History

REVISION NUMBER	REVISION DATE	DESCRIPTION	PAGES CHANGED
1.0	1/11	Initial release	—
1.1	5/11	Updated photos, schematics, BOM, and PCB layouts for the Rev. 7 board.	5, 9, 13-18
2	12/11	Replaced corporate logo. Revised operating system requirements. Corrected Flow Control value.	1 5 11

## Looking for pricing, stock, or lifecycle information?

Click below to explore more details on WIN SOURCE:

- ⊖ [View 78M6613-EVM-1 on WIN SOURCE](#)
- ⊖ [Maxim Integrated Information](#)

## Optimize Your Supply Chain with WIN SOURCE Solutions

- ✓ Global Sourcing Solution
- ✓ Obsolete Management
- ✓ Cost Control Management
- ✓ Shortage Management
- ✓ Alternative Solution
- ✓ Excess Inventory Management