



THE DATASHEET OF
768250004





PRODUCT SPECIFICATION

MEGA-FIT[®] WIRE-TO-BOARD CONNECTOR SYSTEM

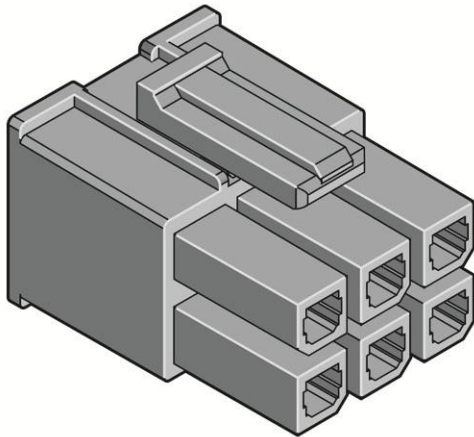

171692 / 170001
RECEPTACLE HOUSING

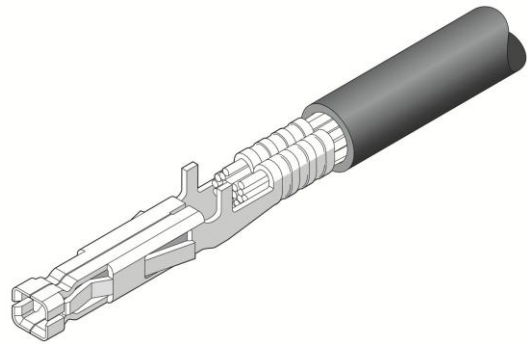

76823 / 172063
FEMALE TERMINAL

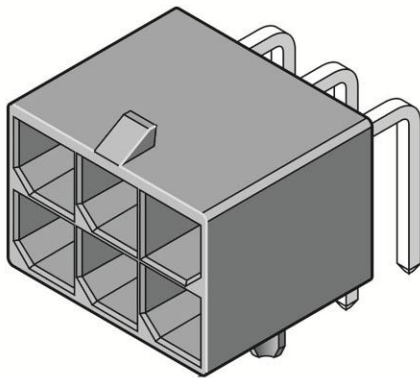

76825 / 172064 / 171596
RIGHT ANGLE HEADER

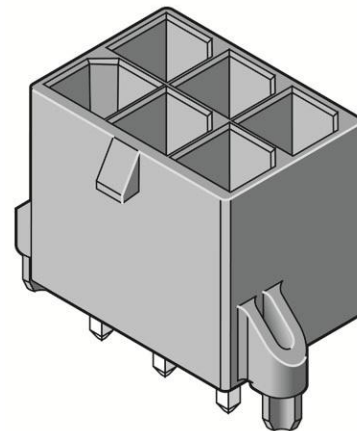

76829 / 172065 / 171597
VERTICAL HEADER

REVISION: B1	ECR/ECN INFORMATION: EC No: UCP2016-2880 DATE: 2016/01/20	TITLE: PRODUCT SPECIFICATION FOR MEGA-FIT[®] WIRE TO BOARD CONNECTOR SYSTEM	SHEET No. 1 of 13
DOCUMENT NUMBER: PS-76823-100	CREATED / REVISED BY: GES	CHECKED BY: JBELL	APPROVED BY: FSMITH



PRODUCT SPECIFICATION

Table of Contents

1.0	SCOPE	3
2.0	PRODUCT DESCRIPTION	3
2.1	Product Name and Series Numbers	3
2.2	Dimensions, Materials, Plating and Markings	3
2.3	Safety Agency Approvals	3
3.0	APPLICABLE DOCUMENTS AND SPECIFICATIONS	4
3.1	Molex Documents	4
3.2	Industry Documents	4
4.0	ELECTRICAL PERFORMANCE RATINGS	4
4.1	Voltage	4
4.2	Applicable Wires	5
4.3	Maximum Current Rating	5
4.4	Temperature	6
4.5	Durability	6
4.6	Current Interruption	7
4.7	Glow Wire	7
5.0	QUALIFICATION	7
6.0	PERFORMANCE	7
6.1	Electrical Performance	7
6.2	Mechanical Performance	8
6.3	Environmental Performance	10
7.0	TEST SEQUENCE GROUPS	12
8.0	SOLDER INFORMATION	14
8.1	Solder Process Temperature	14
8.2	Reflow Solder Profile	14

REVISION: B1	ECR/ECN INFORMATION: EC No: UCP2016-2880 DATE: 2016/01/20	TITLE: PRODUCT SPECIFICATION FOR MEGA-FIT[®] WIRE TO BOARD CONNECTOR SYSTEM	SHEET No. 2 of 13
DOCUMENT NUMBER: PS-76823-100	CREATED / REVISED BY: GES	CHECKED BY: JBELL	APPROVED BY: FSMITH



PRODUCT SPECIFICATION

1.0 SCOPE

This product specification covers the performance requirements and test methods of Mega-fit® 5.70 mm pitch wire to board connector systems terminated with 16 to 12 awg or 1.5 to 4.0mm² stranded wire using crimp technology with tin or gold plating.

2.0 PRODUCT DESCRIPTION

2.1 PRODUCT NAME AND SERIES NUMBER (S)

Table 1 – WIRE-TO-BOARD	
Description	Series Number
Female Crimp Terminal	76823 / 172063
Receptacle Housing	170001 / 171692
Vertical Header	76829 / 172065 / 171597
Right Angle Header	76825 / 172064 / 171596

2.2 DIMENSIONS, MATERIALS, PLATING AND MARKINGS

Dimensions & Plating: See individual sales drawings.
Material: RoHS compliant materials.

2.3 SAFETY AGENCY APPROVALS

2.3.1 UL File Number: UL E29179

UL (12 ckt fully loaded) NON-current interruption	Current interruption per UL1977 Applies when using 170001 Series Only
23 Amps @ 600V (12 AWG or 4.0mm ² wire) 20 Amps @ 600V (14 AWG or 2.5mm ² wire) 18 Amps @ 600V (16 AWG or 1.5mm ² wire)	23 Amps @ 48V AC/DC (12 AWG wire)

2.3.2 IEC License Number per IEC / EN 61984-2009: Certificate Number: 1400024

IEC (12 ckt fully loaded) NON-current interruption
23 Amps @ 600V (12 AWG or 4.0 mm ² wire)

REVISION: B1	ECR/ECN INFORMATION: EC No: UCP2016-2880 DATE: 2016/01/20	TITLE: PRODUCT SPECIFICATION FOR MEGA-FIT® WIRE TO BOARD CONNECTOR SYSTEM	SHEET No. 3 of 13
DOCUMENT NUMBER: PS-76823-100	CREATED / REVISED BY: GES	CHECKED BY: JBELL	APPROVED BY: FSMITH



PRODUCT SPECIFICATION



2.3.3 File Number*: LR-19980_A_000 CLASS 6233-01 and 6233-81

CSA approval meets following standards/test procedures:

- a) CSA std. C22.2 No. 182.3-M1987
- b) UL-1977

* "C" and "US" mark adjacent to CSA signifies that the product has been evaluated to the applicable CSA and ANSI/UL standards, for use in Canada and US respectively.

CSA (single circuit) NON-current interruption
23 Amps @ 600V (12 AWG or 4.0mm ² wire)
20 Amps @ 600V (14 AWG or 2.5mm ² wire)
18 Amps @ 600V (16 AWG or 1.5mm ² wire)

3.0 APPLICABLE DOCUMENTS AND SPECIFICATIONS

3.1 MOLEX DOCUMENTS

See series specific sales drawings and the other sections of this specifications for the necessary referenced documents and specifications.

- Mega Fit Test Summary TS-76823-100
- Molex Solderability Specification SMES-152
- Molex Heat Resistance Specification AS-40000-5013

3.2 INDUSTRY DOCUMENTS

- EIA-364-1000.01
- SAE/USCAR-2
- UL-60950-1
- UL-1977
- CSA STD. C22.2 NO. 182.3-M1987
- IEC / EN 61984

4.0 ELECTRICAL PERFORMANCE RATINGS

4.1 VOLTAGE *

600 Volts AC (RMS) or 600 Volts DC max.

* Voltage rating based on UL 1977. Maximum voltage allowed may vary dependent upon "End Use Application." Refer to the applicable end use standard for additional information on Voltage, Creepage and Clearance requirements.

REVISION: B1	ECR/ECN INFORMATION: EC No: UCP2016-2880 DATE: 2016/01/20	TITLE: PRODUCT SPECIFICATION FOR MEGA-FIT[®] WIRE TO BOARD CONNECTOR SYSTEM	SHEET No. 4 of 13
DOCUMENT NUMBER: PS-76823-100	CREATED / REVISED BY: GES	CHECKED BY: JBELL	APPROVED BY: FSMITH



PRODUCT SPECIFICATION

4.2 APPLICABLE WIRES

Maximum Insulation Diameter and Applicable Wire Gauges	Stranded copper 16 AWG: 3.18 mm / .125 inches MAXIMUM
	Stranded copper 1.5 mm ² : 3.18 mm / .125 inches MAXIMUM
	Stranded copper 14 AWG: 3.66 mm / .144 inches MAXIMUM
	Stranded copper 2.5 mm ² : 3.75 mm / .148 inches MAXIMUM
	Stranded copper 12 AWG: 4.11 mm / .162 inches MAXIMUM
	Stranded copper 4.0 mm ² : 4.11 mm / .162 inches MAXIMUM

4.3 MAXIMUM CURRENT RATING

Current rating is application dependent and may be affected by the wire rating such as listed in UL-60950-1. Each application should be evaluated by the end user for compliance to specific safety agency requirements. The ratings listed in the chart below are per Molex test method based on a 30° C maximum temperature rise over ambient temperature and are provided as a guideline. Appropriate de-rating is required based on circuit size, ambient temperature, copper trace size on the PCB, gross heating from adjacent modules/components and other factors that influence connector performance. Wire size & stranding, tin coated or bare copper, wire length & crimp quality are other factors that influence current rating.

Wire to Board Current Rating (Amp Max.)				
<i>(As tested with tinned awg copper wire and tin or gold plated terminals)</i>				
Connector fully loaded with all circuits powered				
Ckt. Size AWG & metric Wire Size	2	4	6	8-12
12 AWG, 4.0mm ²	23	20	18	16
14 AWG, 2.5mm ²	21	17	15	13
16 AWG, 1.5mm ²	17	15	13	12

Wire to Board Current Rating (Amp Max.)				
<i>(As tested with bare awg copper wire and tin or gold plated terminals)</i>				
Connector fully loaded with all circuits powered				
Ckt. Size AWG & metric Wire Size	2	4	6	8-12
12 AWG, 4.0mm ²	21	18	16	14
14 AWG, 2.5mm ²	19	15	13	11
16 AWG, 1.5mm ²	15	13	11	10

REVISION: B1	ECR/ECN INFORMATION: EC No: UCP2016-2880 DATE: 2016/01/20	TITLE: PRODUCT SPECIFICATION FOR MEGA-FIT[®] WIRE TO BOARD CONNECTOR SYSTEM	SHEET No. 5 of 13
DOCUMENT NUMBER: PS-76823-100	CREATED / REVISED BY: GES	CHECKED BY: JBELL	APPROVED BY: FSMITH



PRODUCT SPECIFICATION

Avg. Temp. Rise vs. Current per EIA-364-70
12 AWG Tinned Copper Wire, 2oz Copper Traces

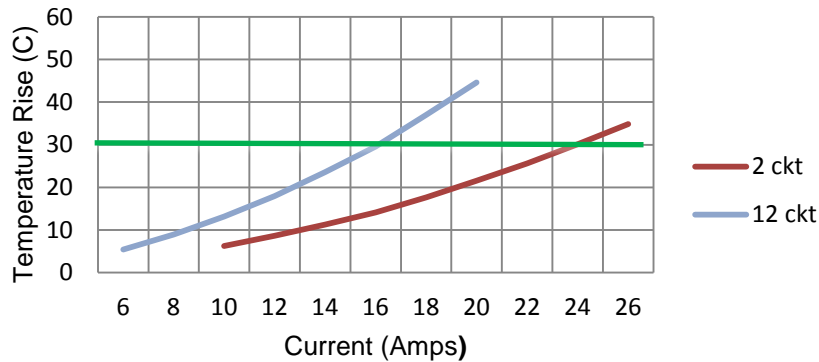

Avg. Temp. Rise vs. Current per EIA-364-70
12 AWG Bare Copper Wire, 2oz Copper Traces

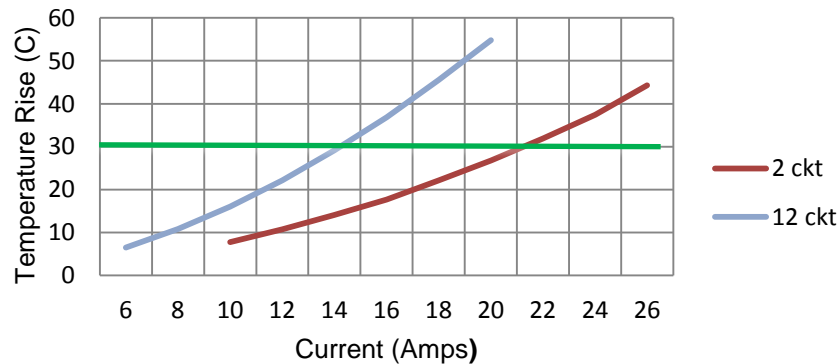

4.4 TEMPERATURE

Tin Plated:

Max. operating temperature range (including T-rise from applied current) is -40°C to 105°C.

Field temperatures and field life: Tested per EIA 364-1000.01 to meet field temperature of 65°C for 10 years life per table-8 in EIA-364-1000.01.

Gold Plated:

Max. operating temperature range (including T-rise from applied current) is -40°C to 120°C, based on test sequence Group VIII, thermal aging at 120°C for 1000 hours.

Field temperatures and field life: Tested per EIA 364-1000.01 to exceed a field temperature of 65°C for 10 years life per table-8 in EIA-364-1000.01.

4.5 DURABILITY

Tin plated: 25 mate/unmates

Gold plated: 200 mate/unmates

As tested in accordance with EIA-364-1000.01 test method (see Sec. 7.0 of this specification). Durability per EIA-364-09.

REVISION: B1	ECR/ECN INFORMATION: EC No: UCP2016-2880 DATE: 2016/01/20	TITLE: PRODUCT SPECIFICATION FOR MEGA-FIT[®] WIRE TO BOARD CONNECTOR SYSTEM	SHEET No. 6 of 13
DOCUMENT NUMBER: PS-76823-100	CREATED / REVISED BY: GES	CHECKED BY: JBELL	APPROVED BY: FSMITH



PRODUCT SPECIFICATION

4.6 CURRENT INTERRUPTION (Applies when using 170001 Series ONLY)

48 Volt AC/DC @ 23 Amp

Tested 250 cycles at 48 volt DC with a test current of 34.5 Amp hot-plug test conducted with all circuits powered with 12 awg wire per UL1977 with tin plated contacts in a 12 circuit housing fully populated.

4.7 Glow Wire

The following series are glow capable:170001, 76825, 76829, 172064. 172065, 171596, 171597. Representative samples were tested and found compliant with EN 60695-2-11-2001 / IEC 60695-2-11-2000 Glow Wire Test Methods for End-Products. These were additionally investigated for compliance with EN 60335-1 / IEC 60335-1 750C/2 sec with no flaming. VDE Test report available upon request.

5.0 QUALIFICATION

Laboratory conditions and sample selection are in accordance with EIA-364-1000.01

6.0 PERFORMANCE

6.1 ELECTRICAL PERFORMANCE

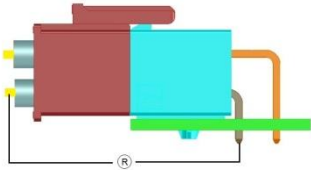
DESCRIPTION	TEST CONDITION	REQUIREMENT
Initial Contact Resistance (Low Level)  Resistance Measure Points	Mate connectors, apply a maximum voltage of 20 mV and a current of 100 mA (measurement locations shown) Per EIA-364-23 Wire resistance and traces shall be removed from the measured value.	Maximum (Initial): Tin: 2 mΩ 15μ" & 30μ" Gold: 2 mΩ
Contact Resistance @Rated Current (Voltage Drop)	Mate connectors; apply the rated current. Per EIA-364-70	Maximum: Tin: 10 mΩ 15μ" & 30μ" Gold: 5 mΩ
Insulation Resistance	Apply 500 VDC between adjacent terminals or ground. Per EIA-364-21	1,000 M Ω minimum
Dielectric Withstanding Voltage	Apply 2200 VAC for 1 minute between adjacent terminals. Per EIA-364-20	No breakdown Current leakage <5mA
Temperature Rise	Mate connectors, measure T- Rise @ Rated Current After 96 Hours. Per EIA-364-70	Temperature rise: 30° C maximum

REVISION: B1	ECR/ECN INFORMATION: EC No: UCP2016-2880 DATE: 2016/01/20	TITLE: PRODUCT SPECIFICATION FOR MEGA-FIT® WIRE TO BOARD CONNECTOR SYSTEM	SHEET No. 7 of 13
DOCUMENT NUMBER: PS-76823-100	CREATED / REVISED BY: GES	CHECKED BY: JBELL	APPROVED BY: FSMITH



PRODUCT SPECIFICATION

6.2 MECHANICAL PERFORMANCE

ITEM	TEST CONDITION	REQUIREMENT
Connector Mating Force	Mate connectors at a rate of 25.4 +/- 6 mm per minute. Per EIA-364-37	Tin plated: 6.8 N MAX. initial mate force per circuit 15μ" & 30μ" Gold plated: 6.0 N MAX. per circuit
Connector Un-mating Force (latch disabled)	Un-mate connectors with latch disabled at a rate of 25.4 +/- 6 mm per minute. Per EIA-364-37	Tin plated: 6.5 N MAX. initial un-mate force per circuit 15μ" & 30μ" Gold plated: 5.6 N MAX. per circuit
Thumb Latch Yield Strength	Mate loaded connectors fully. Pull connectors apart at a rate of 25.4 +/- 6 mm per minute.	68 N MIN.
Durability	Mate connectors 25 cycles for tin plated and 200 cycles for gold plated connectors at a maximum rate of 10 cycles per minute. Per EIA-364-09	Maximum change from initial: Tin: 2 mΩ 15μ" & 30μ" Gold: 2 mΩ
Durability with Environment (Preconditioning)	Mate connectors 5 cycles for tin plated and 20 cycles for gold plated connectors at a maximum rate of 10 cycles per minute. Per EIA-364-09.	Maximum change from initial: Tin: 2 mΩ 15μ" & 30μ" Gold: 2 mΩ
Header Pin Retention Force in Housing Vertical Header	Axial pull force on the vertical header housing away from the PCB at a rate of 25.4 +/- 6 mm per minute.	89 N min per pin
Header Pin Retention Force in Housing Right Angle Header	Axial push force on the pin in the housing at a rate of 25.4 +/- 6 mm per minute.	9.81 N min per pin

REVISION: B1	ECR/ECN INFORMATION: EC No: UCP2016-2880 DATE: 2016/01/20	TITLE: PRODUCT SPECIFICATION FOR MEGA-FIT® WIRE TO BOARD CONNECTOR SYSTEM	SHEET No. 8 of 13
DOCUMENT NUMBER: PS-76823-100	CREATED / REVISED BY: GES	CHECKED BY: JBELL	APPROVED BY: FSMITH



PRODUCT SPECIFICATION

6.2 MECHANICAL PERFORMANCE (CONT.)		
ITEM	TEST CONDITION	REQUIREMENT
PCB Peg Engagement Force (Nominal PCB hole diameter & location)	Insert a header at a rate of 25.4±6 mm/minute. (Applies to parts with PCB retention pegs only)	Header with 2 pegs: 85 N max insertion force Headers with 1 peg: 45 N max insertion force
Crimp Terminal Retention Force (in housing)	Axial pullout force on the terminal in the housing at a rate of 25 ± 6 mm per minute. Per EIA-364-29	30 N MINIMUM retention force
Wire Pull Out Force From Terminal (Axial)	Apply an axial pullout force on the wire at a rate of 25 ± 6 mm per minute.	4.0mm ² = 220 N Min. 12 Awg = 220 N Min. 2.5mm ² = 220 N Min. 14 Awg = 220 N Min. 1.5mm ² = 220 N Min. 16 Awg = 200 N Min. Values may vary depending on crimp tooling. Refer to Molex Applicator Tooling specification.
Vibration (Random)	Mate connectors and vibrate per EIA-364-28 test condition VII-D Tin: 15 minutes each axis. Gold: 1.5 hours each axis.	Maximum Change from Initial: Tin: 2 mΩ 15μ" & 30μ" Gold: 2 mΩ Discontinuity < 1 microsecond
Reseating	Unmate/Mate connectors by hand three cycles	Maximum Change from Initial: Tin: 2 mΩ Except for After Thermal Cycling: Tin: 10 mΩ 15μ" & 30μ" Gold: 2 mΩ
Vibration/Mechanical Shock (SAE/USCAR-2) Tin Plated only	USCAR-2 Rev 6 per sequence M per section 5.9.6, Classification: V1, S1, T2 Shock: 35 G's, 10 shocks per axis Vibration: 8 hours per axis, 1.81 g	No discontinuity of 7 Ω or more for 1 microsecond maximum during Vibration & Shock Total Connector Resistance: Tin: 16.13 mΩ Max (less conductor resistance) Voltage drop was not evaluated

REVISION:

B1

ECR/ECN INFORMATION:

EC No: UCP2016-2880

DATE: 2016/01/20

TITLE:

**PRODUCT SPECIFICATION FOR
MEGA-FIT[®] WIRE TO BOARD
CONNECTOR SYSTEM**

SHEET No.

9 of 13

DOCUMENT NUMBER:

PS-76823-100

CREATED / REVISED BY:

GES

CHECKED BY:

JBELL

APPROVED BY:

FSMITH



PRODUCT SPECIFICATION

6.3 ENVIRONMENTAL PERFORMANCE*

ITEM	TEST CONDITION	REQUIREMENT
Thermal Shock	Mate connectors, expose to 10 cycles from -55°C to 85°C Per EIA-364-32 method A, condition 1	Maximum Change from Initial: Tin: 2 mΩ 15μ" & 30μ" Gold: 2 mΩ
Thermal Aging	Mate Connectors, expose to 240 hours at 105°C Per EIA-364-17 Method A	Maximum Change from Initial: Tin: 2 mΩ 15μ" & 30μ" Gold: 2 mΩ
Thermal Aging Gold Plated Only	Mate Connectors, expose to 1000 hours at 120°C Per EIA-364-17 Method A	Maximum Change from Initial: 15μ" Gold: 6 mΩ 30μ" Gold: 2 mΩ
Thermal Aging (Preconditioning)	Mate Connectors, expose to 120 hours at 105°C Per EIA-364-17 Method A	Maximum Change from Initial: Tin: 2 mΩ 15μ" & 30μ" Gold: 2 mΩ
Cyclic Temperature And Humidity	Mate connectors: expose to 24 cycles from 25 °C / 80% RH to 65 °C / 50% RH ramp time: 0.5hr dwell time: 1hr Per EIA-364-1000.01	Maximum Change from Initial: Tin: 2 mΩ 15μ" & 30μ" Gold: 2 mΩ
Solderability Dip Test	Per Molex test method: SMES-152	Solder area shall have MIN. of 95% solder coverage
Reflow Solder Resistance	Convection reflow solder process 260°C Max per AS-40000-5013	Visual: No damage
Wave Solder Resistance	Dip header terminal tails in solder: Duration: 10±0.5 seconds Solder temperature: 260±5° C Per AS-40000-5013	Visual: No damage
Thermal Cycling Tin Plated Only	Per EIA-364-1000.01 Test Group 5: Cycle mated connector between 15°C±3°C and 85°C±3°C as measured on the part. Ramps should be a minimum of 2°C per minute, and dwell times should insure contacts reach the temperature extremes (minimum of 5 minutes). Humidity is not controlled. Perform 500 cycles.	Maximum Change from Initial: Tin: 10 mΩ

*Environmental tests have been performed based on EIA-364-1000.01

REVISION: B1	ECR/ECN INFORMATION: EC No: UCP2016-2880 DATE: 2016/01/20	TITLE: PRODUCT SPECIFICATION FOR MEGA-FIT® WIRE TO BOARD CONNECTOR SYSTEM	SHEET No. 10 of 13
DOCUMENT NUMBER: PS-76823-100	CREATED / REVISED BY: GES	CHECKED BY: JBELL	APPROVED BY: FSMITH



PRODUCT SPECIFICATION

7.0 TEST SEQUENCE GROUPS

Reliability Test Sequences Based on EIA-364-1000.01 & USCAR-2

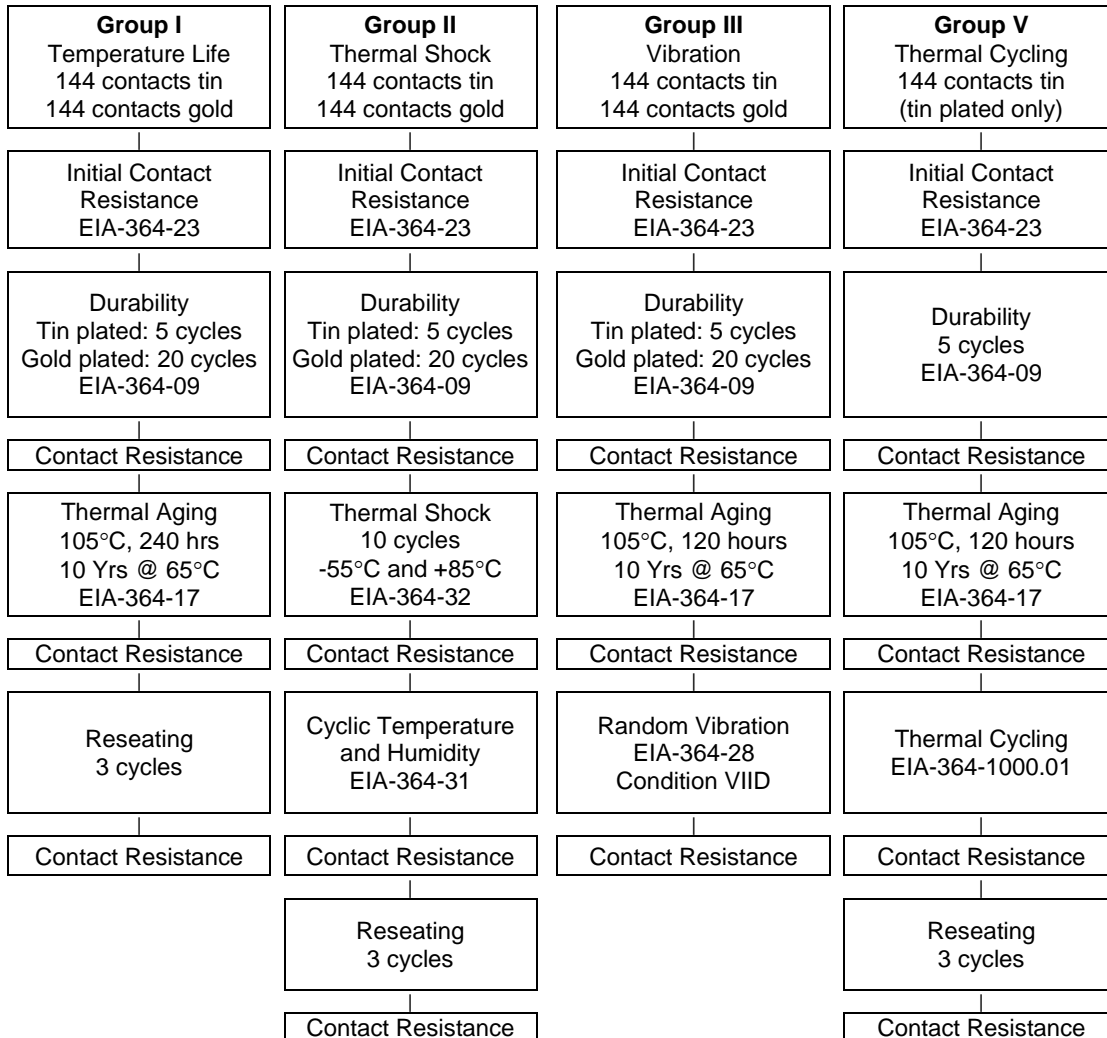

REVISION: B1	ECR/ECN INFORMATION: EC No: UCP2016-2880 DATE: 2016/01/20	TITLE: PRODUCT SPECIFICATION FOR MEGA-FIT® WIRE TO BOARD CONNECTOR SYSTEM	SHEET No. 11 of 13
DOCUMENT NUMBER: PS-76823-100	CREATED / REVISED BY: GES	CHECKED BY: JBELL	APPROVED BY: FSMITH



PRODUCT SPECIFICATION

Group VI Dust 144 contacts tin (tin plated only)	Group VII Durability 144 contacts tin 144 contacts gold	Group VIII Temperature Life 144 contacts gold (gold plated only)	Group IX Uscar-2 Vibration and Shock 144 contacts tin (tin plated only)	Individual Tests
Initial Contact Resistance EIA-364-23	DWV EIA-364-20	Initial Contact Resistance EIA-364-23	Visual Inspection / Initial Contact Resistance EIA-364-23	Connector Mating / Unmating Force
Durability 5 cycles EIA-364-09	Initial Contact Resistance EIA-364-23	Durability 5 cycles EIA-364-09	Durability 10 cycles	Temperature Rise / Voltage Drop
Dust EIA-364-91	Durability Tin plated: 25 cycles Gold plated: 200 cycles EIA-364-09	Contact Resistance	Contact Resistance	Wire pullout force from terminal (axial)
		Thermal Aging 120°C, 250 hrs EIA-364-17	Mechanical shock w/ continuity monitoring	Header Pin Retention in Housing
Contact Resistance	Contact Resistance	Contact Resistance	Random vibration w/ continuity monitoring	Crimped Terminal Retention Force in Housing
Thermal Disturbance EIA-364-1000.01	DWV EIA-364-20	Thermal Aging 120°C, 250 hrs EIA-364-17	Contact Resistance	Wave / Reflow Solder Resistance
Contact Resistance		Contact Resistance	Voltage drop was not conducted due to test setup	Solderability
Reseating 3 cycles		Thermal Aging 120°C, 250 hrs EIA-364-17		Insulation Resistance
Contact Resistance		Contact Resistance		PCB Peg Engagement Forces
		Thermal Aging 120°C, 250 hrs EIA-364-17		Thumb Latch yield strength
		Contact Resistance		
		Crimped terminal retention force in housing		

REVISION: B1	ECR/ECN INFORMATION: EC No: UCP2016-2880 DATE: 2016/01/20	TITLE: PRODUCT SPECIFICATION FOR MEGA-FIT® WIRE TO BOARD CONNECTOR SYSTEM	SHEET No. 12 of 13
DOCUMENT NUMBER: PS-76823-100	CREATED / REVISED BY: GES	CHECKED BY: JBELL	APPROVED BY: FSMITH



PRODUCT SPECIFICATION

8.0 SOLDER INFORMATION

8.1 SOLDER PROCESS TEMPERATURES

Wave Solder: 265°C Max
Reflow Solder: 260°C Max

8.2 REFLOW SOLDERING PROFILE

See AS-40000-5013

REVISION: B1	ECR/ECN INFORMATION: EC No: UCP2016-2880 DATE: 2016/01/20	TITLE: PRODUCT SPECIFICATION FOR MEGA-FIT[®] WIRE TO BOARD CONNECTOR SYSTEM	SHEET No. 13 of 13
DOCUMENT NUMBER: PS-76823-100	CREATED / REVISED BY: GES	CHECKED BY: JBELL	APPROVED BY: FSMITH

Looking for pricing, stock, or lifecycle information?

Click below to explore more details on WIN SOURCE:

 [View 768250004 on WIN SOURCE](#)

 [Molex, LLC Information](#)

Optimize Your Supply Chain with WIN SOURCE Solutions

-  Global Sourcing Solution
-  Obsolete Management
-  Cost Control Management
-  Shortage Management
-  Alternative Solution
-  Excess Inventory Management