



# AT93C46D/AT93C46E

---

## Three-wire Serial EEPROM 1-Kbit (128 x 8 or 64 x 16)

---

### Features

---

- Low-Voltage Operation:
  - $V_{CC} = 1.8V$  to  $5.5V$
- User-Selectable Internally Organized as 128 x 8 (1K) or 64 x 16 (1K)
- Non-Selectable Internal Organization as 64 x 16 (1K), AT93C46E Only
- Industrial Temperature Range:  $-40^{\circ}C$  to  $+85^{\circ}C$
- 2 MHz Clock Rate (5V)
- Self-Timed Write Cycle within 5 ms Maximum
- High Reliability:
  - Endurance: 1,000,000 write cycles
  - Data retention: 100 years
- Green Package Options (Lead-free/Halide-free/RoHS compliant)
- Die Sale Options: Wafer Form and Tape and Reel

### Packages

---

- 8-lead SOIC, 8-lead TSSOP, 8-pad UDFN, 8-lead PDIP and 8-ball VFBGA

**Table of Contents**

Features..... 1

Packages..... 1

1. Package Types (not to scale)..... 4

2. Pin Descriptions.....5

    2.1. Chip Select (CS).....5

    2.2. Serial Data Clock (SK)..... 5

    2.3. Serial Data Input (DI).....5

    2.4. Serial Data Output (DO)..... 5

    2.5. Ground (GND)..... 6

    2.6. Internal Organization (ORG)..... 6

    2.7. Device Power Supply (V<sub>CC</sub>)..... 6

3. Description.....7

    3.1. Block Diagram..... 7

4. Electrical Characteristics..... 8

    4.1. Absolute Maximum Ratings.....8

    4.2. DC and AC Operating Range.....8

    4.3. DC Characteristics..... 8

    4.4. AC Characteristics.....9

    4.5. Synchronous Data Timing..... 11

    4.6. Electrical Specifications.....11

5. Device Commands and Addressing..... 13

    5.1. READ..... 13

    5.2. Erase/Write Enable (EWEN)..... 14

    5.3. Erase/Write Disable (EWDS)..... 14

    5.4. ERASE..... 15

    5.5. WRITE.....15

    5.6. Write All (WRAL)..... 16

    5.7. Erase All (ERAL)..... 16

6. Packaging Information..... 18

    6.1. Package Marking Information.....18

7. Revision History..... 30

The Microchip Website..... 32

Product Change Notification Service..... 32

Customer Support..... 32

Product Identification System..... 33

Microchip Devices Code Protection Feature..... 33

Legal Notice.....34

Trademarks..... 34

Quality Management System..... 35

Worldwide Sales and Service.....36

**1. Package Types (not to scale)**

**8-lead PDIP/SOIC/TSSOP**  
 (Top View)

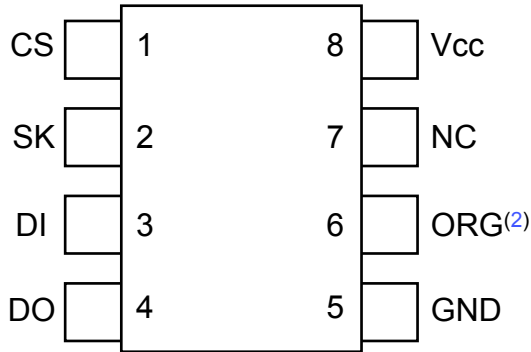

**8-pad UDFN<sup>(1)</sup>**  
 (Top View)

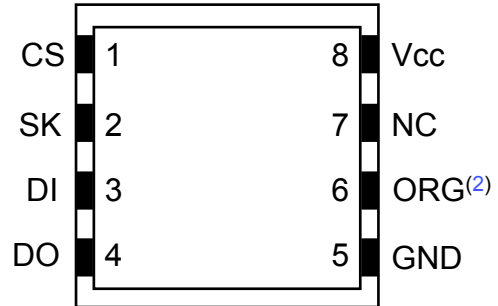

**8-ball VFBGA<sup>(1)</sup>**  
 (Top View)

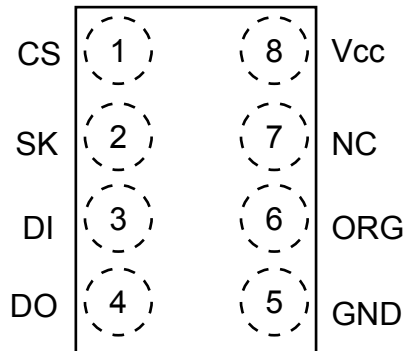

**Note:**

1. This package is only available on the AT93C46D.
2. ORG pin is No Connect (NC) on the AT93C46E device.

## 2. Pin Descriptions

The descriptions of the pins are listed in [Table 2-1](#).

**Table 2-1. Pin Function Table**

Name	8-Lead PDIP	8-Lead SOIC	8-Lead TSSOP	8-Pad UDFN <sup>(1)</sup>	8-Ball VFBGA	Function
CS	1	1	1	1	1	Chip Select
SK	2	2	2	2	2	Serial Data Clock
DI	3	3	3	3	3	Serial Data Input
DO	4	4	4	4	4	Serial Data Output
GND	5	5	5	5	5	Ground
ORG <sup>(2)</sup>	6	6	6	6	6	Internal Organization
NC	7	7	7	7	7	No Connect
VCC	8	8	8	8	8	Device Power Supply

**Note:**

1. The exposed pad on this package can be connected to GND or left floating.
2. The Internal Organization (ORG) pin is a No Connect (NC) on the AT93C46E device.

### 2.1 Chip Select (CS)

The Chip Select (CS) pin is used to control device selection. The AT93C46D/AT93C46E is selected when the CS pin is high. When the device is not selected, data will not be accepted via the Serial Data Input (DI) pin, and the Serial Output (DO) pin will remain in a high-impedance state.

### 2.2 Serial Data Clock (SK)

The Serial Data Clock (SK) pin is used to synchronize the communication between a master and the AT93C46D/AT93C46E. Instructions, addresses or data present on the Serial Data Input (DI) pin is latched in on the rising edge of SK, while output on the Serial Data Output (DO) pin is also clocked out on the rising edge of SK.

### 2.3 Serial Data Input (DI)

The Serial Data Input (DI) pin is used to transfer data into the device. It receives instructions, addresses and data. Data is latched on the rising edge of the Serial Data Clock (SK).

### 2.4 Serial Data Output (DO)

The Serial Data Output (DO) pin is used to transfer data out of the AT93C46D/AT93C46E. During a read sequence, data is shifted out on this pin after the rising edge of the Serial Data Clock (SK).

This pin also outputs the Ready/Busy status of the part if CS is brought high after being low for a minimum of  $t_{CS}$  and an erase or write operation has been initiated.

**2.5 Ground (GND)**

The ground reference for the power supply. The Ground (GND) pin should be connected to the system ground.

**2.6 Internal Organization (ORG)**

The Internal Organization (ORG) pin is used to select between the x16 or x8 memory organizations of the device. When the ORG pin is tied to  $V_{CC}$ , the x16 memory organization is selected. When the ORG pin is tied to  $V_{SS}$ , the x8 memory organization is selected.

If the ORG pin is left unconnected and the application does not load the input beyond the capability of the internal 1 M $\Omega$  pull-up resistor, then the x16 organization is selected.

**Note:** This pin is a No Connect (NC) on the AT93C46E.

**2.7 Device Power Supply ( $V_{CC}$ )**

The Device Power Supply ( $V_{CC}$ ) pin is used to supply the source voltage to the device. Operations at invalid  $V_{CC}$  voltages may produce spurious results and should not be attempted.

### 3. Description

The AT93C46D provides 1,024 bits of Serial Electrically Erasable and Programmable Read-Only Memory (EEPROM) organized as 64 words of 16 bits each (when the ORG pin is connected to  $V_{CC}$ ) and 128 words of 8 bits each (when the ORG pin is tied to ground). The device is optimized for use in many industrial and commercial applications where low-power and low-voltage operations are essential. The AT93C46D is available in space-saving 8-lead SOIC, 8-lead TSSOP, 8-pad UDFN, 8-lead PDIP, and 8-ball VFBGA packages. All packages operate from 1.8V to 5.5V.

The AT93C46E provides 1,024 bits of Serial Electrically Erasable and Programmable Read-Only Memory (EEPROM) organized as 64 words of 16 bits each only. The AT93C46E does not offer the ORG pin so organization is not user-selectable on this device. The device is optimized for use in many industrial and commercial applications where low-power and low-voltage operations are essential. The AT93C46E is also available in space-saving 8-lead SOIC, 8-lead TSSOP, and 8-lead PDIP packages. All packages operate from 1.8V to 5.5V.

The AT93C46D/AT93C46E is enabled through the Chip Select (CS) pin and accessed via a three-wire serial interface consisting of Data Input (DI), Data Output (DO), and Serial Data Clock (SK). Upon receiving a READ instruction at DI, the address is decoded, and the data is clocked out serially on the DO pin. The write cycle is completely self-timed, and no separate erase cycle is required before write. The write cycle is only enabled when the part is in the Erase/Write Enable state. When CS is brought high following the initiation of a write cycle, the DO pin outputs the Ready/Busy status of the part.

#### 3.1 Block Diagram

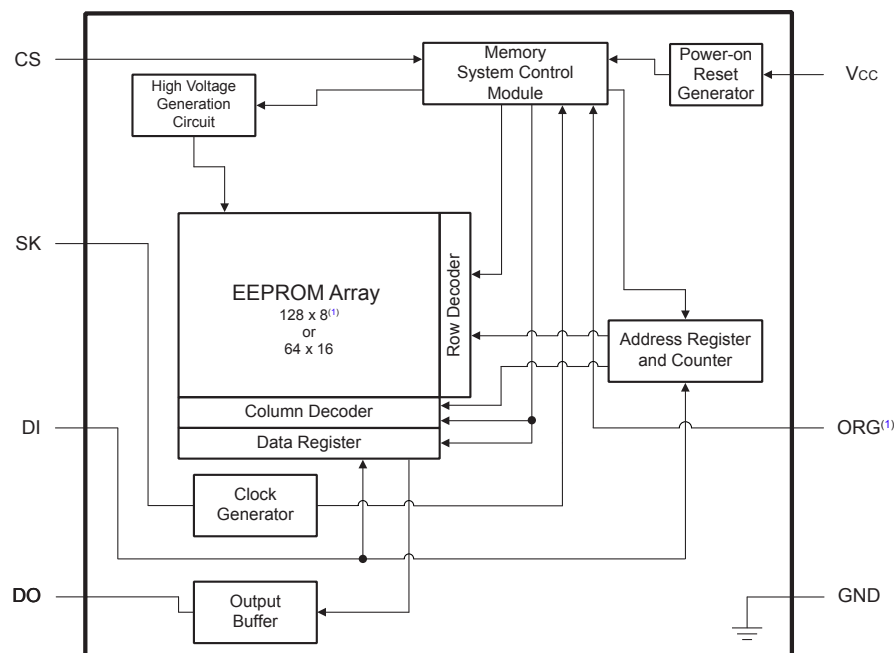

#### Note:

1. The organization of the AT93C46E is not selectable by the ORG pin and defaults to 64x16. If the x16 organization is the mode of choice and pin 6 (ORG) is left unconnected, Microchip recommends using AT93C46E device.

### 4. Electrical Characteristics

#### 4.1 Absolute Maximum Ratings

Temperature under bias	-55°C to +125°C
Storage temperature	-65°C to +150°C
V <sub>CC</sub>	6.25V
Voltage on any pin with respect to ground	-1.0V to +7.0V
DC output current	5.0 mA
ESD protection	2 kV

**Note:** Stresses above those listed under “Absolute Maximum Ratings” may cause permanent damage to the device. This is a stress rating only and functional operation of the device at these or any other conditions above those indicated in the operation listings of this specification is not implied. Exposure to absolute maximum rating conditions for extended periods may affect device reliability.

#### 4.2 DC and AC Operating Range

Table 4-1. DC and AC Operating Range

AT93C46D/AT93C46E		
Operating Temperature (Case)	Industrial Temperature Range	-40°C to +85°C
V <sub>CC</sub> Power Supply	Low-Voltage Grade	1.8V to 5.5V

#### 4.3 DC Characteristics

Table 4-2. DC Characteristics<sup>(1)</sup>

Parameter	Symbol	Minimum	Typical	Maximum	Units	Test Conditions
Supply Voltage	V <sub>CC1</sub>	1.8	—	5.5	V	
Supply Voltage	V <sub>CC2</sub>	2.7	—	5.5	V	
Supply Voltage	V <sub>CC3</sub>	4.5	—	5.5	V	
Supply Current	I <sub>CC1</sub>	—	0.5	2.0	mA	V <sub>CC</sub> = 5.0V, Read at 1 MHz
Supply Current	I <sub>CC2</sub>	—	0.5	2.0	mA	V <sub>CC</sub> = 5.0V, Write at 1 MHz
Standby Current (1.8V Option)	ISB1	—	0.4	1.0	μA	V <sub>CC</sub> = 1.8V, CS = 0V
Standby Current (2.7V Option)	ISB2	—	6.0	10.0	μA	V <sub>CC</sub> = 2.7V, CS = 0V
Standby Current (5.0V Option)	ISB3	—	10.0	15.0	μA	V <sub>CC</sub> = 5.0V, CS = 0V

.....continued

Parameter	Symbol	Minimum	Typical	Maximum	Units	Test Conditions
Input Leakage Current	$I_{IL}$	—	0.1	1.0	$\mu\text{A}$	$V_{IN} = 0 \text{ to } V_{CC}$
Output Leakage Current	$I_{LO}$	—	0.1	1.0	$\mu\text{A}$	$V_{IN} = 0 \text{ to } V_{CC}$
Input Low-Voltage	$V_{IL1}$	-0.6	—	0.8	V	$2.7\text{V} \leq V_{CC} \leq 5.5\text{V}$ (Note 2)
Input High-Voltage	$V_{IH1}$	2.0	—	$V_{CC} + 1$	V	$2.7\text{V} \leq V_{CC} \leq 5.5\text{V}$ (Note 2)
Input Low-Voltage	$V_{IL2}$	-0.6	—	$V_{CC} \times 0.3$	V	$1.8\text{V} \leq V_{CC} \leq 2.7\text{V}$ (Note 2)
Input High-Voltage	$V_{IH2}$	$V_{CC} \times 0.7$	—	$V_{CC} + 1$	V	$1.8\text{V} \leq V_{CC} \leq 2.7\text{V}$ (Note 2)
Output Low-Voltage	$V_{OL1}$	—	—	0.4	V	$2.7\text{V} \leq V_{CC} \leq 5.5\text{V}$ , $I_{OL} = 2.1 \text{ mA}$
Output High-Voltage	$V_{OH1}$	2.4	—	—	V	$2.7\text{V} \leq V_{CC} \leq 5.5\text{V}$ , $I_{OH} = -0.4 \text{ mA}$
Output Low-Voltage	$V_{OL2}$	—	—	0.2	V	$1.8\text{V} \leq V_{CC} \leq 2.7\text{V}$ , $I_{OL} = 0.15 \text{ mA}$
Output High-Voltage	$V_{OH2}$	$V_{CC} - 0.2$	—	—	V	$1.8\text{V} \leq V_{CC} \leq 2.7\text{V}$ , $I_{OH} = -100 \mu\text{A}$

**Note:**

1. Applicable over recommended operating range from:  $T_A = -40^\circ\text{C}$  to  $+85^\circ\text{C}$ ,  $V_{CC} = 1.8\text{V}$  to  $5.5\text{V}$  (unless otherwise noted).
2.  $V_{IL}$  min and  $V_{IH}$  max are reference only and are not tested.

## 4.4 AC Characteristics

Table 4-3. AC Characteristics<sup>(1)</sup>

Parameter	Symbol	Minimum	Typical	Maximum	Units	Test Conditions
Clock Frequency, SK	$f_{SK}$	0	—	2	MHz	$4.5\text{V} \leq V_{CC} \leq 5.5\text{V}$
		0	—	1	MHz	$2.7\text{V} \leq V_{CC} \leq 5.5\text{V}$
		0	—	250	kHz	$1.8\text{V} \leq V_{CC} \leq 5.5\text{V}$
High Time, SK	$t_{SKH}$	250	—	—	ns	$4.5\text{V} \leq V_{CC} \leq 5.5\text{V}$
		250	—	—	ns	$2.7\text{V} \leq V_{CC} \leq 5.5\text{V}$
		1000	—	—	ns	$1.8\text{V} \leq V_{CC} \leq 5.5\text{V}$
Low Time, SK	$t_{SKL}$	250	—	—	ns	$4.5\text{V} \leq V_{CC} \leq 5.5\text{V}$
		250	—	—	ns	$2.7\text{V} \leq V_{CC} \leq 5.5\text{V}$
		1000	—	—	ns	$1.8\text{V} \leq V_{CC} \leq 5.5\text{V}$

# AT93C46D/AT93C46E

## Electrical Characteristics

.....continued						
Parameter	Symbol	Minimum	Typical	Maximum	Units	Test Conditions
Minimum CS Low Time	$t_{CS}$	250	—	—	ns	$4.5V \leq V_{CC} \leq 5.5V$
		250	—	—	ns	$2.7V \leq V_{CC} \leq 5.5V$
		1000	—	—	ns	$1.8V \leq V_{CC} \leq 5.5V$
CS Setup Time	$t_{CSS}$	50	—	—	ns	$4.5V \leq V_{CC} \leq 5.5V$ , Relative to SK
		50	—	—	ns	$2.7V \leq V_{CC} \leq 5.5V$ , Relative to SK
		200	—	—	ns	$1.8V \leq V_{CC} \leq 5.5V$ , Relative to SK
DI Setup Time	$t_{DIS}$	100	—	—	ns	$4.5V \leq V_{CC} \leq 5.5V$ , Relative to SK
		100	—	—	ns	$2.7V \leq V_{CC} \leq 5.5V$ , Relative to SK
		400	—	—	ns	$1.8V \leq V_{CC} \leq 5.5V$ , Relative to SK
CS Hold Time	$t_{CSH}$	0	—	—	ns	Relative to SK
DI Hold Time	$t_{DIH}$	100	—	—	ns	$4.5V \leq V_{CC} \leq 5.5V$ , Relative to SK
		100	—	—	ns	$2.7V \leq V_{CC} \leq 5.5V$ , Relative to SK
		400	—	—	ns	$1.8V \leq V_{CC} \leq 5.5V$ , Relative to SK
Output Delay to 1	$t_{PD1}$	—	—	250	ns	$4.5V \leq V_{CC} \leq 5.5V$
		—	—	250	ns	$2.7V \leq V_{CC} \leq 5.5V$
		—	—	1000	ns	$1.8V \leq V_{CC} \leq 5.5V$
Output Delay to 0	$t_{PD0}$	—	—	250	ns	$4.5V \leq V_{CC} \leq 5.5V$
		—	—	250	ns	$2.7V \leq V_{CC} \leq 5.5V$
		—	—	1000	ns	$1.8V \leq V_{CC} \leq 5.5V$
CS to Status Valid	$t_{SV}$	—	—	250	ns	$4.5V \leq V_{CC} \leq 5.5V$
		—	—	250	ns	$2.7V \leq V_{CC} \leq 5.5V$
		—	—	1000	ns	$1.8V \leq V_{CC} \leq 5.5V$ ,

.....continued						
Parameter	Symbol	Minimum	Typical	Maximum	Units	Test Conditions
CS to DO in High-impedance	$t_{DF}$	—	—	100	ns	$4.5V \leq V_{CC} \leq 5.5V$ , CS = $V_{IL}$
		—	—	250	ns	$2.7V \leq V_{CC} \leq 5.5V$ , CS = $V_{IL}$
		—	—	400	ns	$1.8V \leq V_{CC} \leq 5.5V$ , CS = $V_{IL}$
Write Cycle Time	$t_{WP}$	0.1	3	5	ms	$1.8V \leq V_{CC} \leq 5.5V$

**Note:**

1. Applicable over recommended operating range from  $T_A = -40^\circ\text{C}$  to  $+85^\circ\text{C}$ ,  $V_{CC} = \text{As Specified}$ ,  $C_L = 1$  TTL Gate and 100 pF (unless otherwise noted).

## 4.5 Synchronous Data Timing

Figure 4-1. Synchronous Data Timing

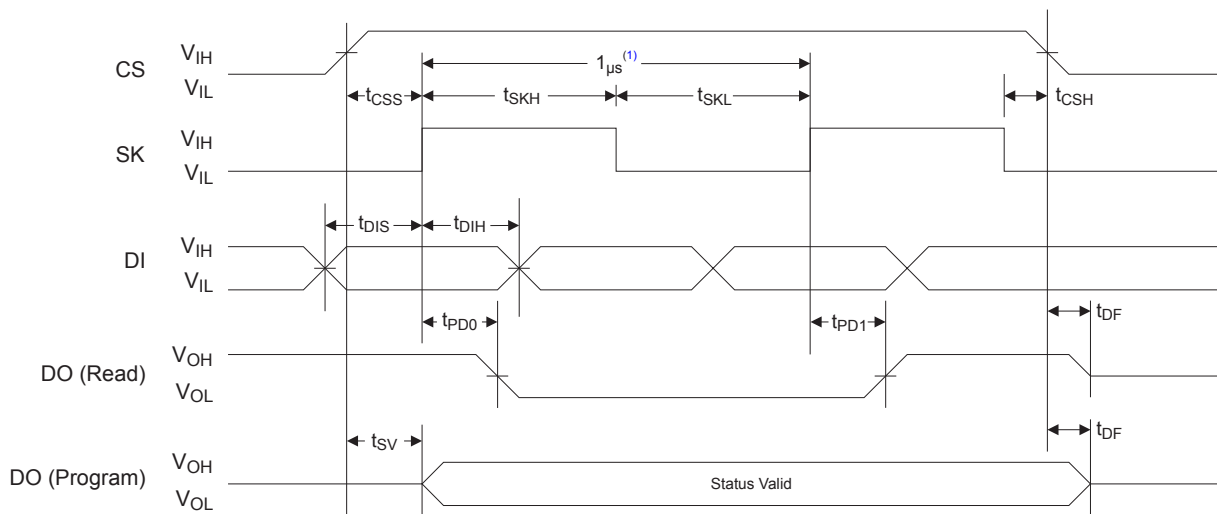

**Note:**

1. This is the minimum SK period.

## 4.6 Electrical Specifications

### 4.6.1 Power-Up Requirements and Reset Behavior

During a power-up sequence, the  $V_{CC}$  supplied to the AT93C46D/AT93C46E should monotonically rise from GND to the minimum  $V_{CC}$  level, as specified in Table 4-1, with a slew rate no faster than  $0.1 \text{ V}/\mu\text{s}$ .

#### 4.6.1.1 Device Reset

To prevent inadvertent write operations or any other spurious events from occurring during a power-up sequence, the AT93C46D/AT93C46E includes a Power-on Reset (POR) circuit. Upon power-up, the device will not respond to any commands until the  $V_{CC}$  level crosses the internal voltage threshold ( $V_{POR}$ ) that brings the device out of Reset and into Standby mode.

The system designer must ensure the instructions are not sent to the device until the  $V_{CC}$  supply has reached a stable value greater than or equal to the minimum  $V_{CC}$  level. Additionally, once the  $V_{CC}$  is greater than or equal to the minimum  $V_{CC}$  level, the bus master must wait at least  $t_{PUP}$  before sending the first command to the device. See Power-up Conditions<sup>(1)</sup> for the values associated with these power-up parameters.

**Table 4-4. Power-up Conditions<sup>(1)</sup>**

Symbol	Parameter	Min.	Max.	Units
$t_{PUP}$	Time required after $V_{CC}$ is stable before the device can accept commands	100	—	$\mu$ s
$V_{POR}$	Power-on Reset Threshold Voltage	—	1.5	V
$t_{POFF}$	Minimum time at $V_{CC} = 0V$ between power cycles	500	—	ms

**Note:**

1. These parameters are characterized but they are not 100% tested in production.

If an event occurs in the system where the  $V_{CC}$  level supplied to the AT93C46D/AT93C46E drops below the maximum  $V_{POR}$  level specified, it is recommended that a full power cycle sequence be performed by first driving the  $V_{CC}$  pin to GND, waiting at least the minimum  $t_{POFF}$  time and then performing a new power-up sequence in compliance with the requirements defined in this section.

### 4.6.2 Pin Capacitance

**Table 4-5. Pin Capacitance<sup>(1)</sup>**

Symbol	Test Condition	Max.	Units	Conditions
$C_{OUT}$	Output Capacitance (DO)	5	pF	$V_{OUT} = 0V$
$C_{IN}$	Input Capacitance (CS, SK, DI, ORG)	5	pF	$V_{IN} = 0V$

**Note:**

1. This parameter is characterized but is not 100% tested in production.

### 4.6.3 EEPROM Cell Performance Characteristics

**Table 4-6. EEPROM Cell Performance Characteristics**

Operation	Test Condition	Min.	Max.	Units
Write Endurance <sup>(1)</sup>	$T_A = 25^\circ C$ , $V_{CC} = 5.0V$	1,000,000	—	Write Cycles
Data Retention <sup>(1)</sup>	$T_A = 55^\circ C$	100	—	Years

**Note:**

1. Performance is determined through characterization and the qualification process.

## 5. Device Commands and Addressing

The AT93C46D/AT93C46E is accessed via a simple and versatile three-wire serial communication interface. Device operation is controlled by seven instructions issued by the Host processor. A valid instruction starts with a rising edge of CS and consists of a Start bit (SB), followed by the appropriate opcode, and the desired memory address location.

**Table 5-1. AT93C46D/AT93C46E Instruction Set**

Instruction	SB	Opcode	Address		Data		Comments
			X8 <sup>(1)</sup>	X16 <sup>(1)</sup>	X8	X16	
READ	1	10	A <sub>6</sub> -A <sub>0</sub>	A <sub>5</sub> -A <sub>0</sub>			Reads data stored in memory at specified address.
EWEN	1	00	11XXXXXXX	11XXXXXXX			Write Enable must precede all programming modes.
ERASE	1	11	A <sub>6</sub> -A <sub>0</sub>	A <sub>5</sub> -A <sub>0</sub>			Erases memory location A <sub>N</sub> -A <sub>0</sub> .
WRITE	1	01	A <sub>6</sub> -A <sub>0</sub>	A <sub>5</sub> -A <sub>0</sub>	D <sub>7</sub> -D <sub>0</sub>	D <sub>15</sub> -D <sub>0</sub>	Writes memory location A <sub>N</sub> -A <sub>0</sub> .
ERAL	1	00	10XXXXXXX	10XXXXXXX			Erases all memory locations. Valid only at VCC3. See <a href="#">Table 4-2</a> .
WRAL	1	00	01XXXXXXX	01XXXXXXX	D <sub>7</sub> -D <sub>0</sub>	D <sub>15</sub> -D <sub>0</sub>	Writes all memory locations. Valid only at VCC3. See <a href="#">Table 4-2</a> .
EWDS	1	00	00XXXXXXX	00XXXXXXX			Disables all programming instructions.

**Note:**

- The 'x' in the address field represent a "don't care" bit, and must be sent to the device.

**Table 5-2. Organization Key for Timing Diagrams**

I/O	AT93C46D/AT93C46E (1K)	
	X8 <sup>(1)</sup>	X16
A <sub>N</sub>	A <sub>6</sub>	A <sub>5</sub>
D <sub>N</sub>	D <sub>7</sub>	D <sub>15</sub>

**Note:**

- The internal organization of the AT93C46E is x16 only.

### 5.1 READ

The READ instruction contains the address code for the memory location to be read. After the instruction and address are decoded, data from the selected memory location is available at the DO pin. Output data changes are synchronized with the rising edges of the SK pin.

**Note:** A dummy bit (logic '0') precedes the 8-bit or 16-bit data output string.

**Figure 5-1. READ Timing**

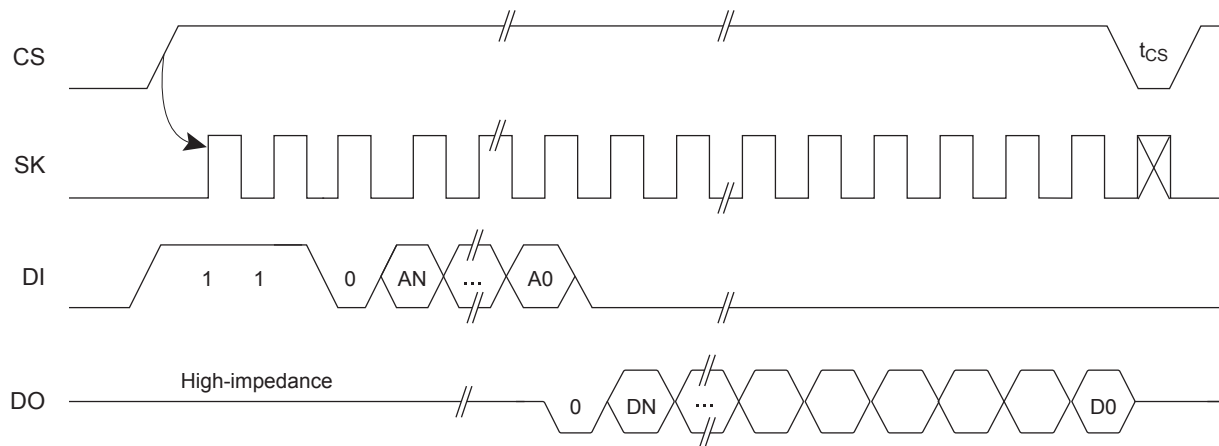

## 5.2 Erase/Write Enable (EWEN)

To ensure data integrity, the part automatically goes into the Erase/Write Disable (EWDS) state when power is first applied. An Erase/Write Enable (EWEN) instruction must be executed first before any programming instructions can be carried out.

**Note:** Once in the write enabled state, programming remains enabled until an EWDS instruction is executed, or  $V_{CC}$  power is removed from the part.

**Figure 5-2. EWEN Timing**

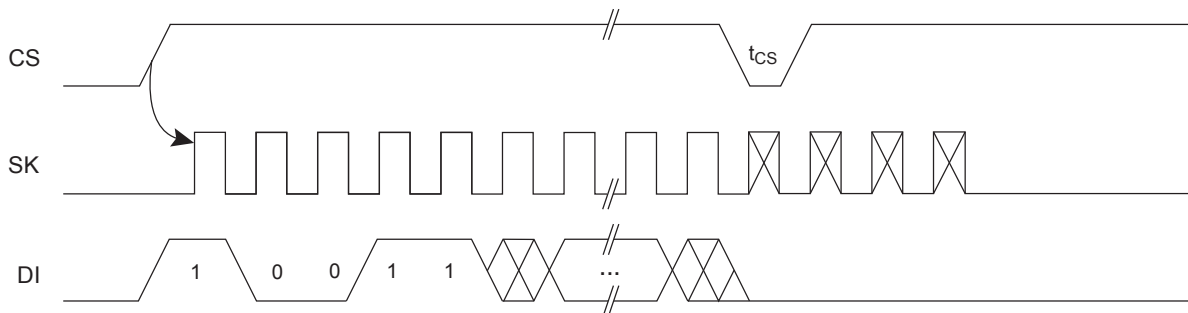

## 5.3 Erase/Write Disable (EWDS)

To protect against accidental data disturbance, the Erase/Write Disable (EWDS) instruction disables all programming modes and should be executed after all programming operations. The operation of the READ instruction is independent of both the EWEN and EWDS instructions and can be executed at any time.

**Figure 5-3. EWDS Timing**

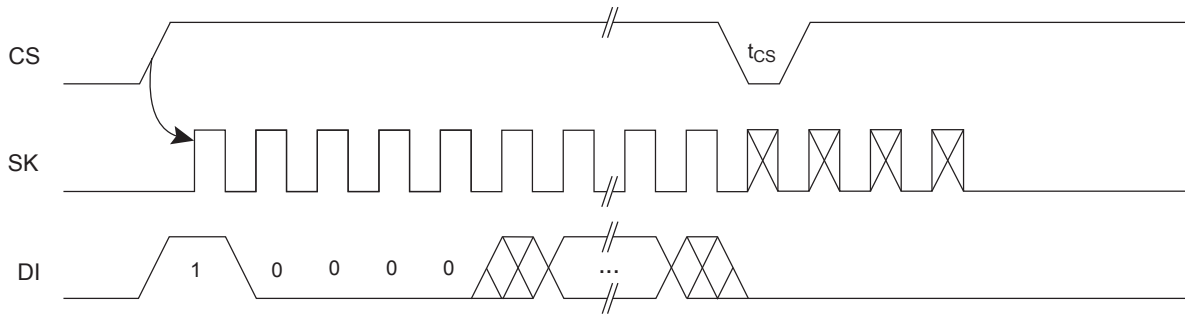

## 5.4 ERASE

The `ERASE` instruction programs all bits in the specified memory location to the logic '1' state. The self-timed erase cycle starts once the `ERASE` instruction and address are decoded. The DO pin outputs the Ready/Busy status of the part if CS is brought high after being kept low for a minimum of  $t_{CS}$ . A logic '1' at the DO pin indicates that the selected memory location has been erased, and the part is ready for another instruction.

**Figure 5-4. ERASE Timing**

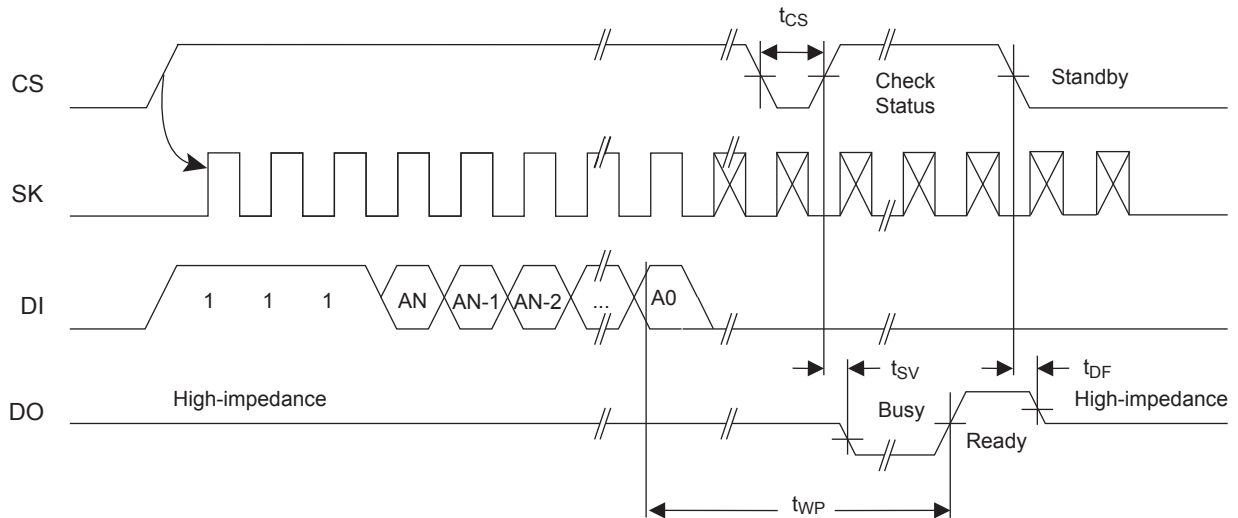

## 5.5 WRITE

The `WRITE` instruction contains the 8 bits or 16 bits of data to be written into the specified memory location. The self-timed programming cycle,  $t_{WP}$ , starts after the last bit of data is received at DI pin. The DO pin outputs the Ready/Busy status of the part if CS is brought high after being kept low for a minimum of  $t_{CS}$ . A logic '0' at DO indicates that programming is still in progress. A logic '1' indicates that the memory location at the specified address has been written with the data pattern contained in the instruction, and the part is ready for further instructions. A Ready/Busy status cannot be obtained if CS is brought high after the end of the self-timed programming cycle,  $t_{WP}$ .

**Figure 5-5. WRITE Timing**

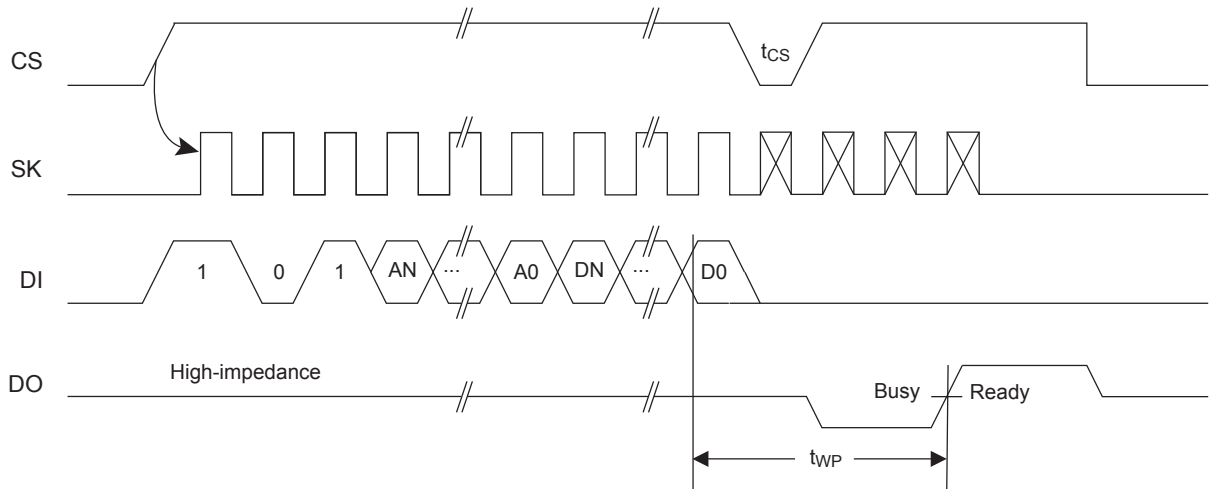

## 5.6 Write All (WRAL)

The Write All ( $WRAL$ ) instruction programs all memory locations with the data patterns specified in the instruction. The DO pin outputs the Ready/Busy status of the part if CS is brought high after being kept low for a minimum of  $t_{CS}$ .

**Note:** The  $WRAL$  instruction is valid only at  $V_{CC3}$  (see [Table 4-2](#)).

**Figure 5-6. WRAL Timing**

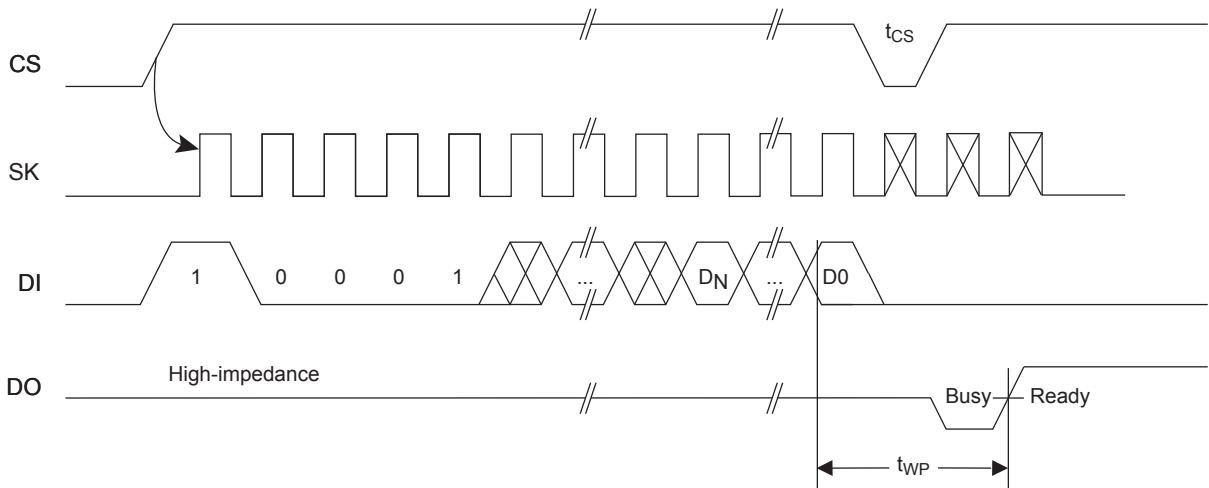

## 5.7 Erase All (ERAL)

The Erase All ( $ERAL$ ) instruction programs every bit in the memory array to the logic '1' state and is primarily used for testing purposes. The DO pin outputs the Ready/Busy status of the part if CS is brought high after being kept low for a minimum of  $t_{CS}$ .

**Note:** The  $ERAL$  instruction is valid only at  $V_{CC3}$  (see [Table 4-2](#)).

**Figure 5-7. ERAL Timing**

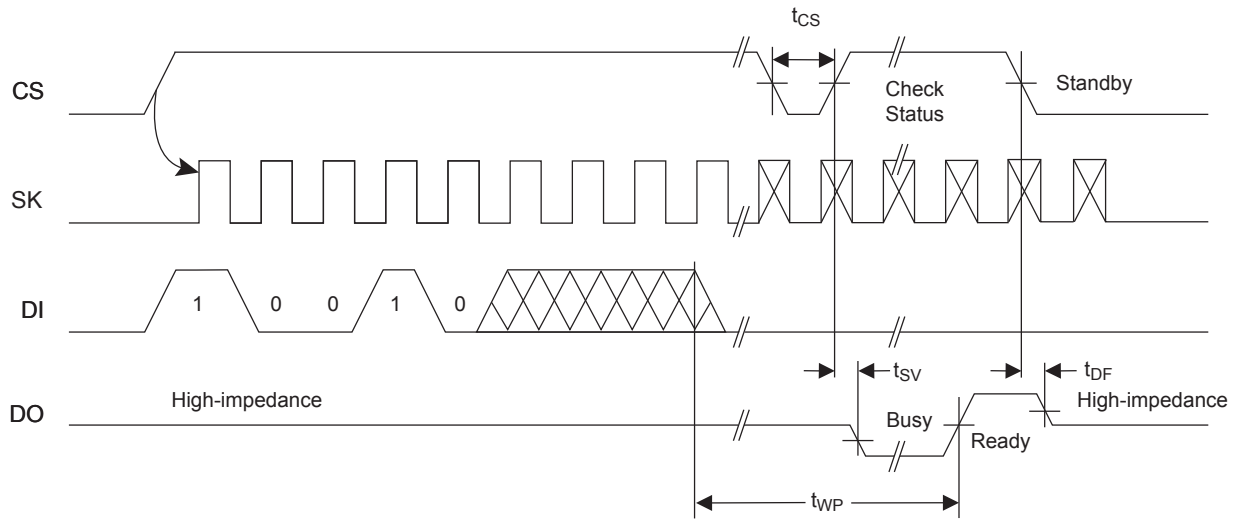

## 6. Packaging Information

### 6.1 Package Marking Information

### AT93C46D and AT93C46E: Package Marking Information

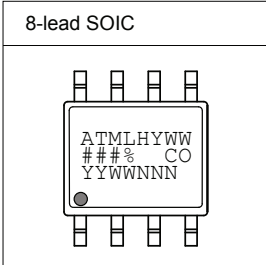
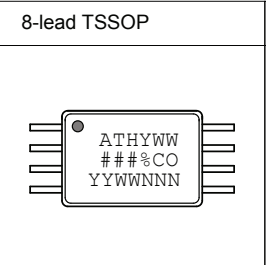
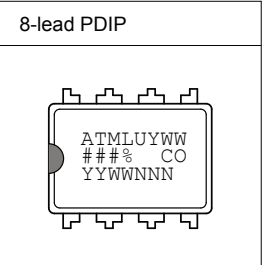
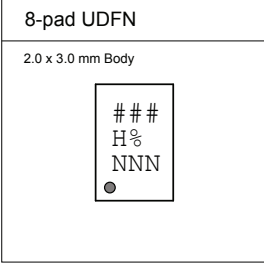
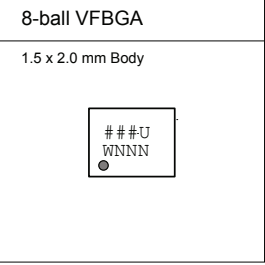
8-lead SOIC	8-lead TSSOP	8-lead PDIP
		
8-pad UDFN 2.0 x 3.0 mm Body		8-ball VFBGA 1.5 x 2.0 mm Body
		

Note 1: ● designates pin 1  
 Note 2: Package drawings are not to scale

<b>Catalog Number Truncation</b>			
AT93C46D		Truncation Code ###: 46D	
AT93C46E		Truncation Code ###: 46E	
<b>Date Codes</b>			<b>Voltages</b>
YY = Year	Y = Year	WW = Work Week of Assembly	% = Minimum Voltage
16: 2016    20: 2020	6: 2016    0: 2020	02: Week 2	L: 1.8V min
17: 2017    21: 2021	7: 2017    1: 2021	04: Week 4	
18: 2018    22: 2022	8: 2018    2: 2022	...	
19: 2019    23: 2023	9: 2019    3: 2023	52: Week 52	
<b>Country of Origin</b>		<b>Device Grade</b>	
CO = Country of Origin		H or U: Industrial Grade	
<b>Atmel Truncation</b>			
AT: Atmel			
ATM: Atmel			
ATML: Atmel			
<b>Lot Number or Trace Code</b>			
NNN = Alphanumeric Trace Code (2 Characters for Small Packages)			

# AT93C46D/AT93C46E

## Packaging Information

### 8-Lead Plastic Small Outline (SN) - Narrow, 3.90 mm (.150 In.) Body [SOIC]

**Note:** For the most current package drawings, please see the Microchip Packaging Specification located at <http://www.microchip.com/packaging>

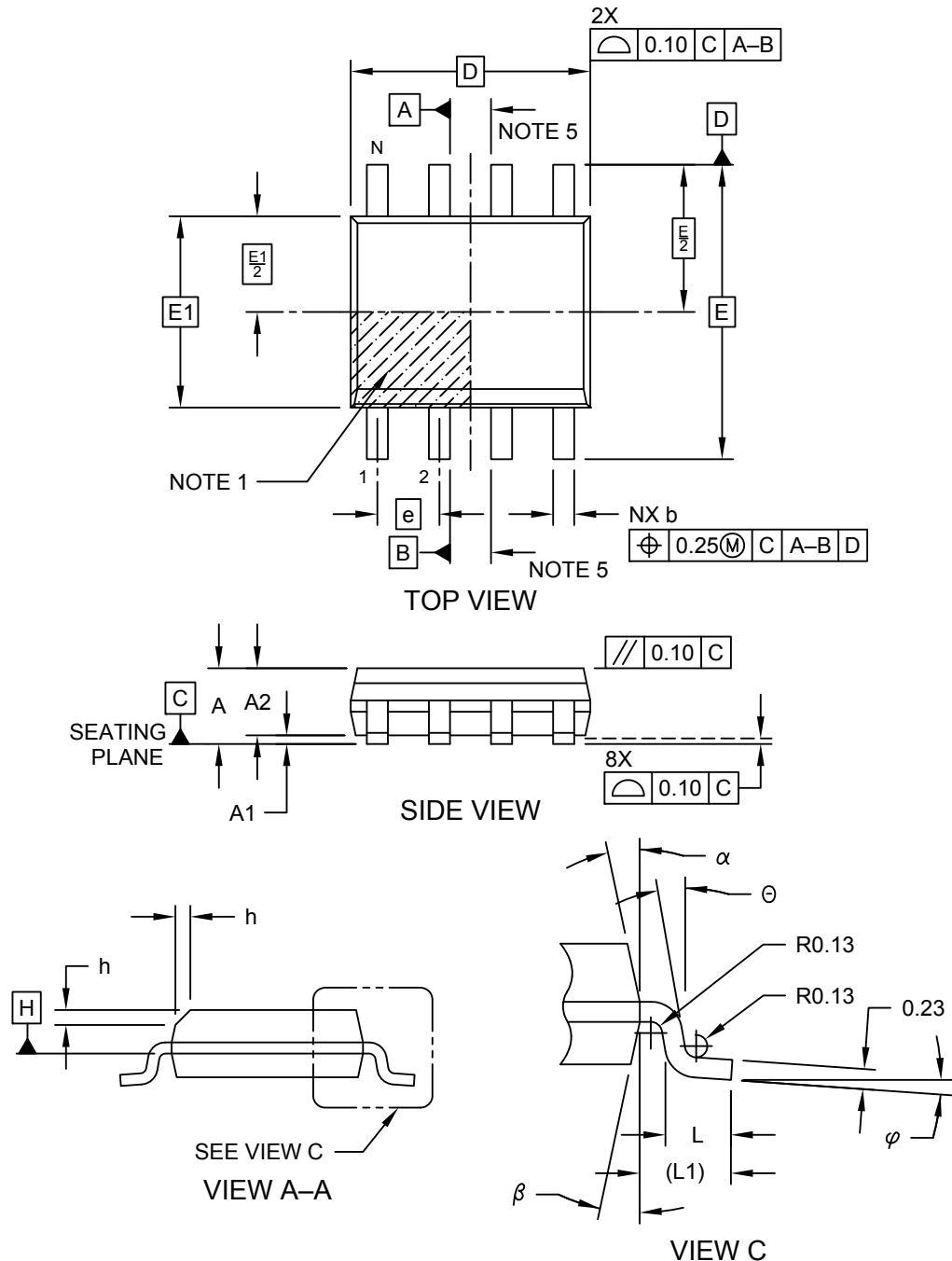

Microchip Technology Drawing No. C04-057-SN Rev E Sheet 1 of 2

# AT93C46D/AT93C46E

## Packaging Information

### 8-Lead Plastic Small Outline (SN) - Narrow, 3.90 mm (.150 In.) Body [SOIC]

**Note:** For the most current package drawings, please see the Microchip Packaging Specification located at <http://www.microchip.com/packaging>

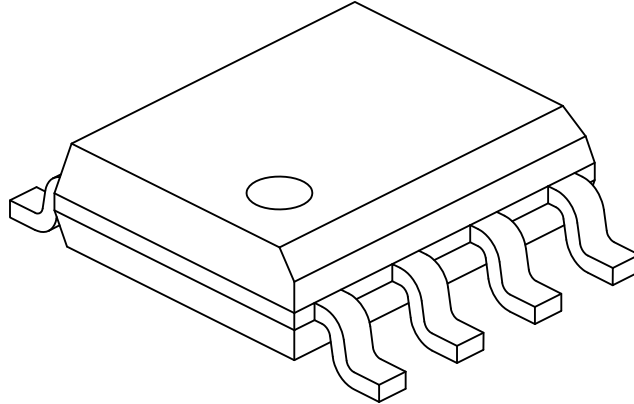

Dimension Limits	Units	MILLIMETERS		
		MIN	NOM	MAX
Number of Pins	N	8		
Pitch	e	1.27 BSC		
Overall Height	A	-	-	1.75
Molded Package Thickness	A2	1.25	-	-
Standoff §	A1	0.10	-	0.25
Overall Width	E	6.00 BSC		
Molded Package Width	E1	3.90 BSC		
Overall Length	D	4.90 BSC		
Chamfer (Optional)	h	0.25	-	0.50
Foot Length	L	0.40	-	1.27
Footprint	L1	1.04 REF		
Foot Angle	φ	0°	-	8°
Lead Thickness	c	0.17	-	0.25
Lead Width	b	0.31	-	0.51
Mold Draft Angle Top	α	5°	-	15°
Mold Draft Angle Bottom	β	5°	-	15°

**Notes:**

- Pin 1 visual index feature may vary, but must be located within the hatched area.
- § Significant Characteristic
- Dimensions D and E1 do not include mold flash or protrusions. Mold flash or protrusions shall not exceed 0.15mm per side.
- Dimensioning and tolerancing per ASME Y14.5M  
BSC: Basic Dimension. Theoretically exact value shown without tolerances.  
REF: Reference Dimension, usually without tolerance, for information purposes only.
- Datums A & B to be determined at Datum H.

Microchip Technology Drawing No. C04-057-SN Rev E Sheet 2 of 2

### 8-Lead Plastic Small Outline (SN) - Narrow, 3.90 mm Body [SOIC]

**Note:** For the most current package drawings, please see the Microchip Packaging Specification located at <http://www.microchip.com/packaging>

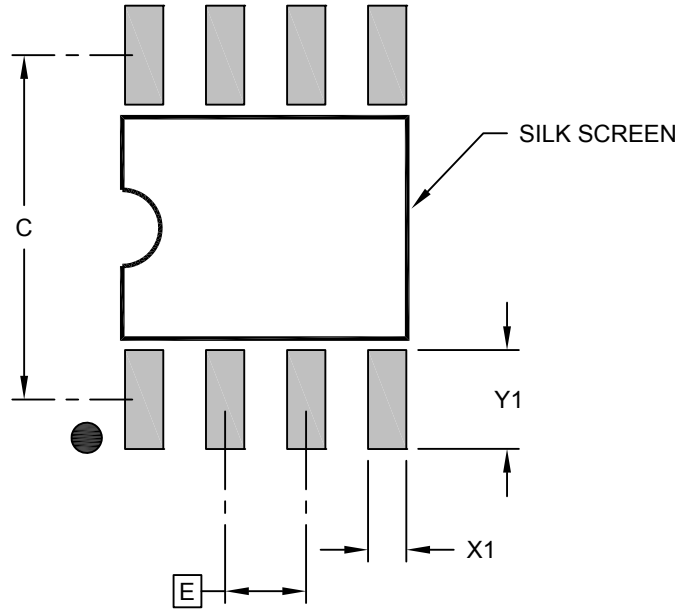

RECOMMENDED LAND PATTERN

		Units	MILLIMETERS		
		Dimension Limits	MIN	NOM	MAX
Contact Pitch	E	1.27 BSC			
Contact Pad Spacing	C		5.40		
Contact Pad Width (X8)	X1				0.60
Contact Pad Length (X8)	Y1				1.55

**Notes:**

1. Dimensioning and tolerancing per ASME Y14.5M  
 BSC: Basic Dimension. Theoretically exact value shown without tolerances.

Microchip Technology Drawing C04-2057-SN Rev E

# AT93C46D/AT93C46E

## Packaging Information

### 8-Lead Plastic Thin Shrink Small Outline (ST) – 4.4 mm Body [TSSOP]

**Note:** For the most current package drawings, please see the Microchip Packaging Specification located at <http://www.microchip.com/packaging>

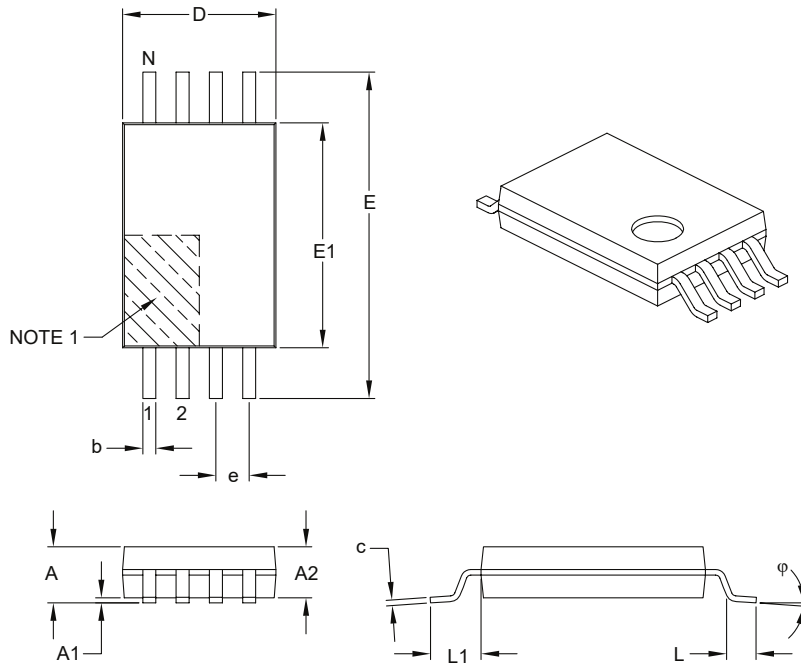

Dimension Limits	Units	MILLIMETERS		
		MIN	NOM	MAX
Number of Pins	N	8		
Pitch	e	0.65 BSC		
Overall Height	A	–	–	1.20
Molded Package Thickness	A2	0.80	1.00	1.05
Standoff	A1	0.05	–	0.15
Overall Width	E	6.40 BSC		
Molded Package Width	E1	4.30	4.40	4.50
Molded Package Length	D	2.90	3.00	3.10
Foot Length	L	0.45	0.60	0.75
Footprint	L1	1.00 REF		
Foot Angle	$\phi$	0°	–	8°
Lead Thickness	c	0.09	–	0.20
Lead Width	b	0.19	–	0.30

**Notes:**

- Pin 1 visual index feature may vary, but must be located within the hatched area.
- Dimensions D and E1 do not include mold flash or protrusions. Mold flash or protrusions shall not exceed 0.15 mm per side.
- Dimensioning and tolerancing per ASME Y14.5M.

BSC: Basic Dimension. Theoretically exact value shown without tolerances.

REF: Reference Dimension, usually without tolerance, for information purposes only.

Microchip Technology Drawing C04-086B

# AT93C46D/AT93C46E

## Packaging Information

8-Lead Plastic Thin Shrink Small Outline (ST) - 4.4 mm Body [TSSOP]

**Note:** For the most current package drawings, please see the Microchip Packaging Specification located at <http://www.microchip.com/packaging>

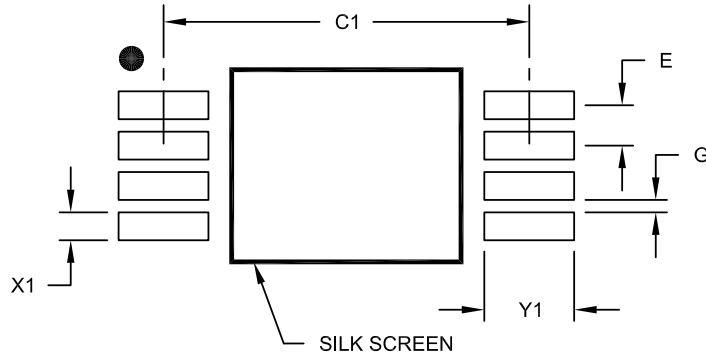

### RECOMMENDED LAND PATTERN

Dimension Limits	Units	MILLIMETERS		
		MIN	NOM	MAX
Contact Pitch	E	0.65 BSC		
Contact Pad Spacing	C1		5.90	
Contact Pad Width (X8)	X1			0.45
Contact Pad Length (X8)	Y1			1.45
Distance Between Pads	G	0.20		

**Notes:**

1. Dimensioning and tolerancing per ASME Y14.5M

BSC; Basic Dimension. Theoretically exact value shown without tolerances.

Microchip Technology Drawing No. C04-2086A

# AT93C46D/AT93C46E

## Packaging Information

### 8-Lead Ultra Thin Plastic Dual Flat, No Lead Package (Q4B) - 2x3 mm Body [UDFN] Atmel Legacy YNZ Package

**Note:** For the most current package drawings, please see the Microchip Packaging Specification located at <http://www.microchip.com/packaging>

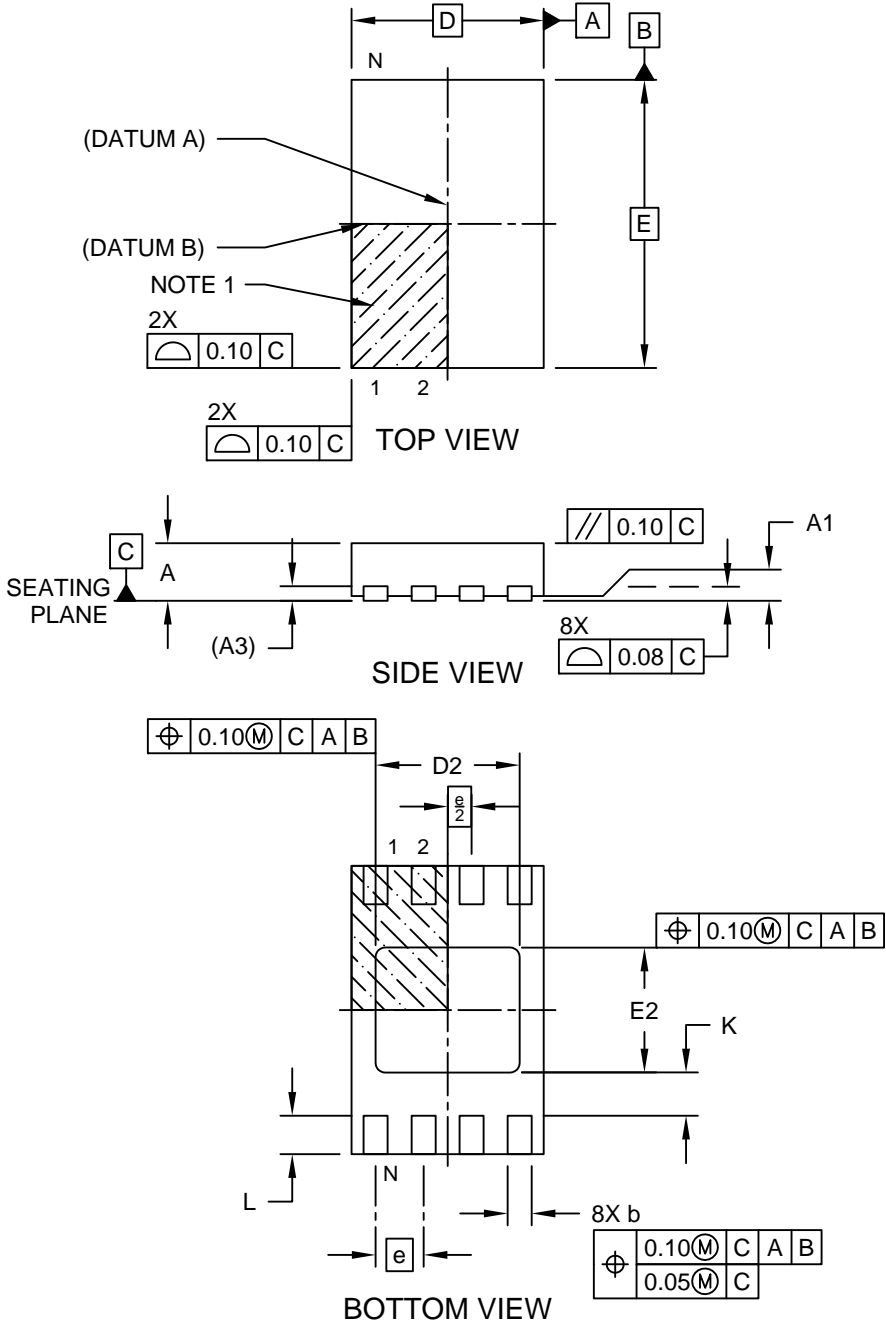

Microchip Technology Drawing C04-21355-Q4B Rev A Sheet 1 of 2

# AT93C46D/AT93C46E

## Packaging Information

### 8-Lead Ultra Thin Plastic Dual Flat, No Lead Package (Q4B) - 2x3 mm Body [UDFN] Atmel Legacy YNZ Package

**Note:** For the most current package drawings, please see the Microchip Packaging Specification located at <http://www.microchip.com/packaging>

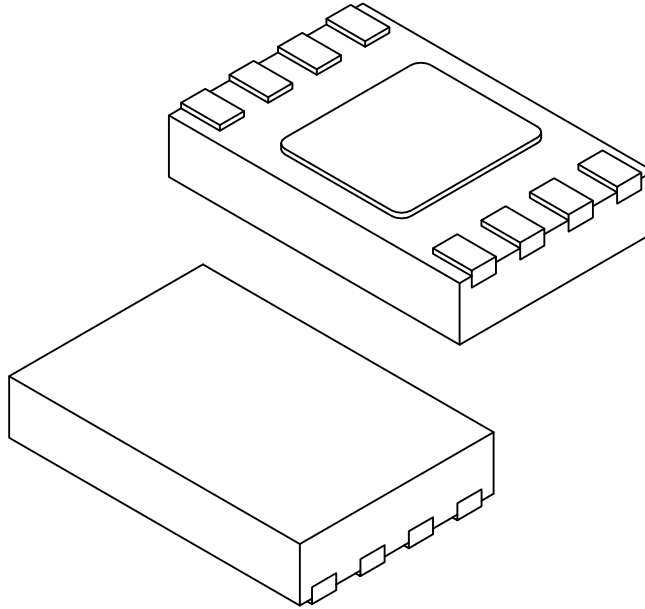

Dimension Limits	Units	MILLIMETERS		
		MIN	NOM	MAX
Number of Terminals	N	8		
Pitch	e	0.50 BSC		
Overall Height	A	0.50	0.55	0.60
Standoff	A1	0.00	0.02	0.05
Terminal Thickness	A3	0.152 REF		
Overall Length	D	2.00 BSC		
Exposed Pad Length	D2	1.40	1.50	1.60
Overall Width	E	3.00 BSC		
Exposed Pad Width	E2	1.20	1.30	1.40
Terminal Width	b	0.18	0.25	0.30
Terminal Length	L	0.35	0.40	0.45
Terminal-to-Exposed-Pad	K	0.20	-	-

**Notes:**

1. Pin 1 visual index feature may vary, but must be located within the hatched area.
2. Package is saw singulated
3. Dimensioning and tolerancing per ASME Y14.5M

BSC: Basic Dimension. Theoretically exact value shown without tolerances.

REF: Reference Dimension, usually without tolerance, for information purposes only.

Microchip Technology Drawing C04-21355-Q4B Rev A Sheet 2 of 2

### 8-Lead Ultra Thin Plastic Dual Flat, No Lead Package (Q4B) - 2x3 mm Body [UDFN] Atmel Legacy YNZ Package

**Note:** For the most current package drawings, please see the Microchip Packaging Specification located at <http://www.microchip.com/packaging>

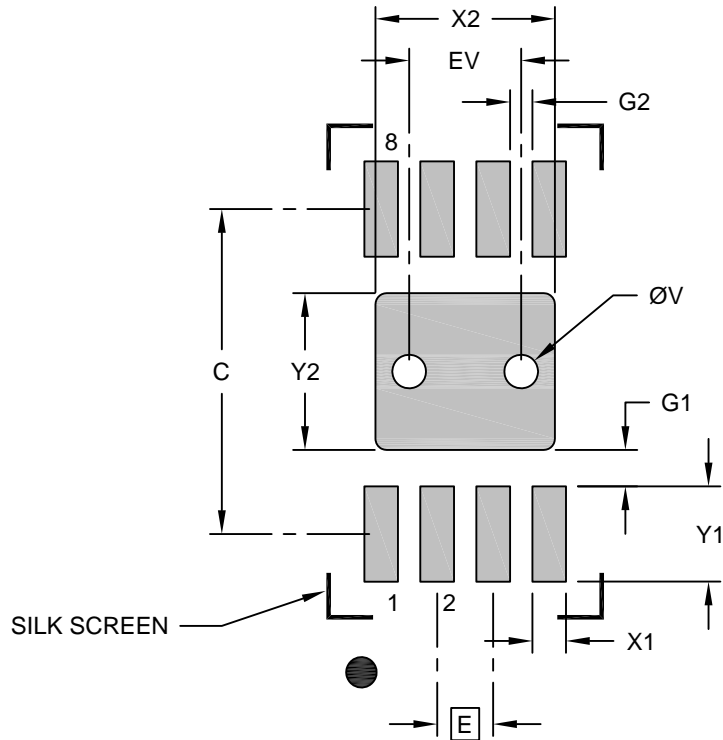

**RECOMMENDED LAND PATTERN**

Dimension Limits	Units	MILLIMETERS		
		MIN	NOM	MAX
Contact Pitch	E	0.50 BSC		
Optional Center Pad Width	X2			1.60
Optional Center Pad Length	Y2			1.40
Contact Pad Spacing	C		2.90	
Contact Pad Width (X8)	X1			0.30
Contact Pad Length (X8)	Y1			0.85
Contact Pad to Center Pad (X8)	G1	0.20		
Contact Pad to Contact Pad (X6)	G2	0.33		
Thermal Via Diameter	V		0.30	
Thermal Via Pitch	EV		1.00	

**Notes:**

1. Dimensioning and tolerancing per ASME Y14.5M  
BSC: Basic Dimension. Theoretically exact value shown without tolerances.
2. For best soldering results, thermal vias, if used, should be filled or tented to avoid solder loss during reflow process

Microchip Technology Drawing C04-21355-Q4B Rev A

# AT93C46D/AT93C46E

## Packaging Information

### 8-Lead Plastic Dual In-Line (P) - 300 mil Body [PDIP]

**Note:** For the most current package drawings, please see the Microchip Packaging Specification located at <http://www.microchip.com/packaging>

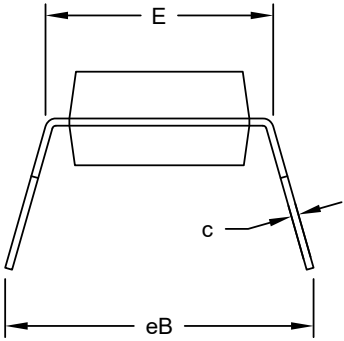
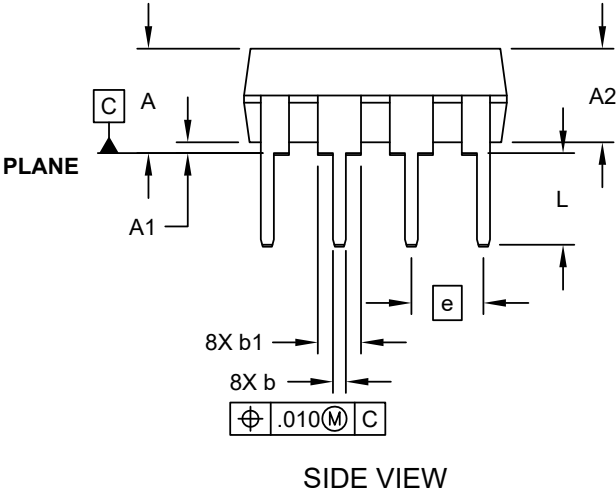
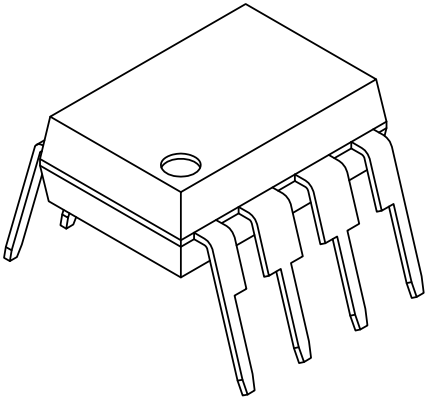
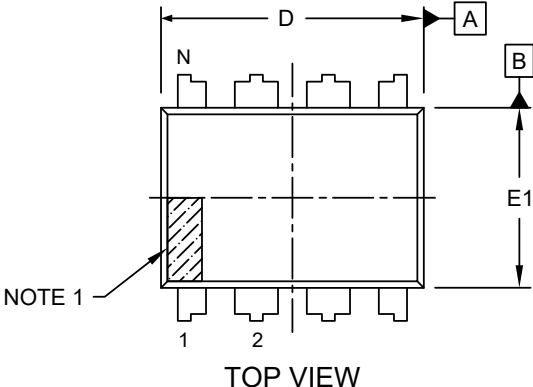

Microchip Technology Drawing No. C04-018D Sheet 1 of 2

# AT93C46D/AT93C46E

## Packaging Information

### 8-Lead Plastic Dual In-Line (P) - 300 mil Body [PDIP]

**Note:** For the most current package drawings, please see the Microchip Packaging Specification located at <http://www.microchip.com/packaging>

ALTERNATE LEAD DESIGN  
(VENDOR DEPENDENT)

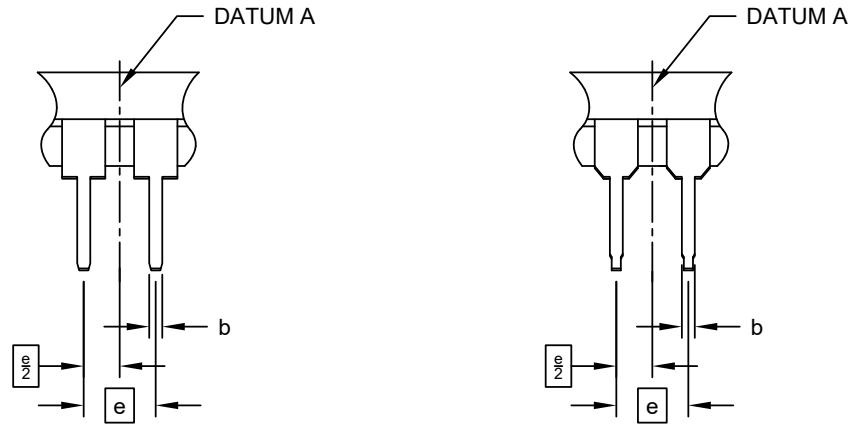

		Units	INCHES		
Dimension Limits			MIN	NOM	MAX
Number of Pins	N		8		
Pitch	e		.100 BSC		
Top to Seating Plane	A	-	-	-	.210
Molded Package Thickness	A2	.115	.130		.195
Base to Seating Plane	A1	.015	-	-	-
Shoulder to Shoulder Width	E	.290	.310		.325
Molded Package Width	E1	.240	.250		.280
Overall Length	D	.348	.365		.400
Tip to Seating Plane	L	.115	.130		.150
Lead Thickness	c	.008	.010		.015
Upper Lead Width	b1	.040	.060		.070
Lower Lead Width	b	.014	.018		.022
Overall Row Spacing	§	eB	-	-	.430

**Notes:**

1. Pin 1 visual index feature may vary, but must be located within the hatched area.
2. § Significant Characteristic
3. Dimensions D and E1 do not include mold flash or protrusions. Mold flash or protrusions shall not exceed .010" per side.
4. Dimensioning and tolerancing per ASME Y14.5M  
BSC: Basic Dimension. Theoretically exact value shown without tolerances.

Microchip Technology Drawing No. C04-018D Sheet 2 of 2

# AT93C46D/AT93C46E

## Packaging Information

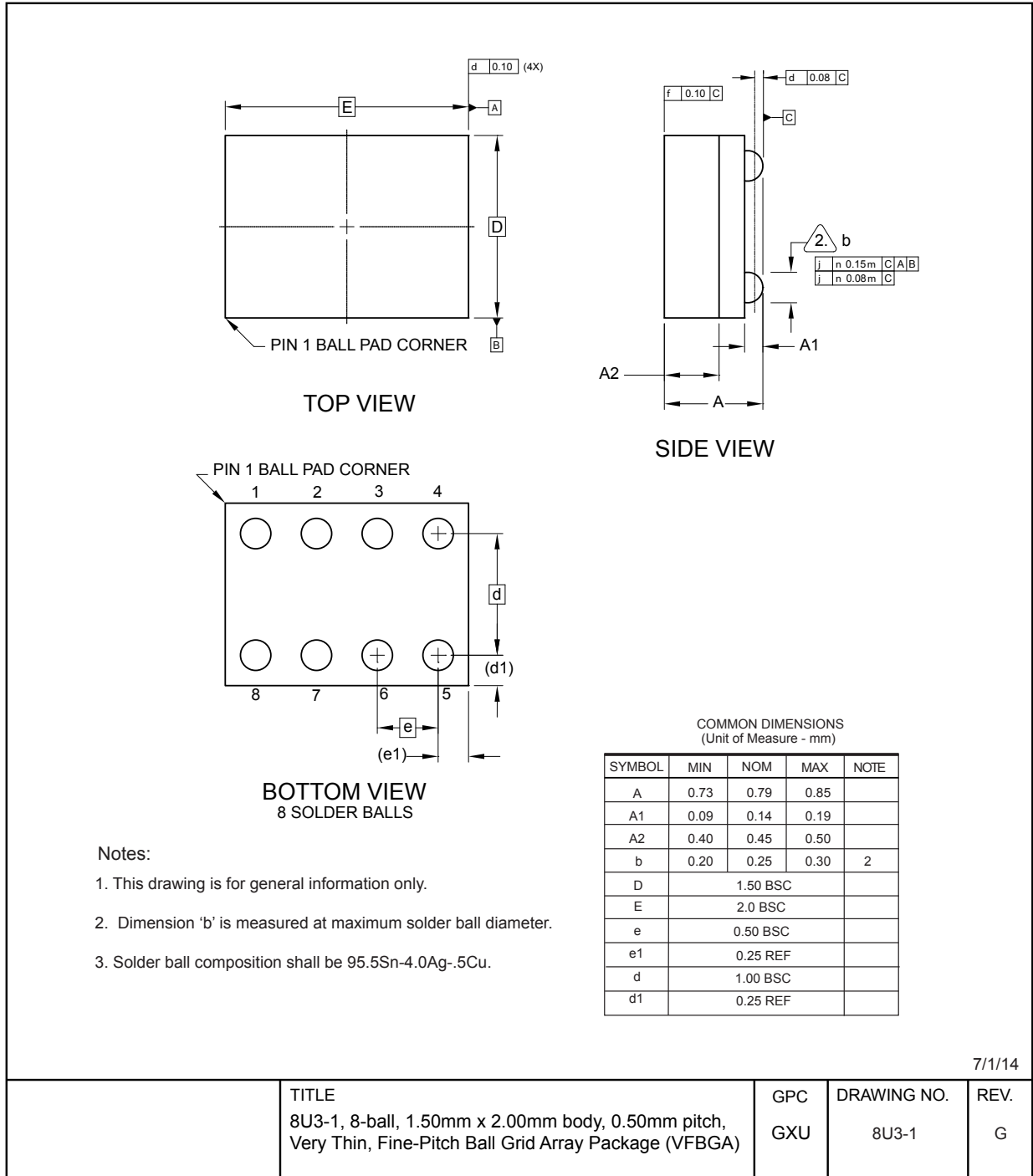

7/1/14

**Note:** For the most current package drawings, please see the Microchip Packaging Specification located at <http://www.microchip.com/packaging>.

## 7. Revision History

### **Revision A (July 2019)**

Updated to the Microchip template. Microchip DS20006224 replaces Atmel documents 5193 and 5207. Updated Package Marking Information. Removed lead finish designation. Updated trace code format in package markings. Updated section content throughout for clarification. Updated the 8U3-1 VFBGA package drawing. Updated the PDIP, SOIC, TSSOP and UDFN package drawings to Microchip format.

### **Atmel AT93C46E 5207 Revision F (January 2015)**

Updated ordering information section.

### **Atmel AT93C46D 5193 Revision H (January 2015)**

Added the UDFN expanded quantity option and the ordering information section. Updated the 8MA2 and 8P3 package drawings.

### **Atmel AT93C46E 5207 Revision E (October 2014)**

Added the part markings and ordering code detail. Updated the package outline drawings and the 8A2 to 8X. Updated the template, Atmel logos, and the disclaimer page.

### **Atmel AT93C46D 5193 Revision G (August 2014)**

Updated package drawings, template, logos, and disclaimer page.

### **Atmel AT93C46E 5207 Revision D (January 2008)**

Removed the 'preliminary' status.

### **Atmel AT93C46D 5193 Revision F (January 2008)**

Removed the 'preliminary' status.

### **Atmel AT93C46E 5207 Revision C (November 2007)**

Modified the 'max' value in AC Characteristics table.

### **Atmel AT93C46D 5193 Revision E (November 2007)**

Modified the 'max' value in AC Characteristics table.

### **Atmel AT93C46E 5207 Revision B (August 2007)**

Modified Part Marking Schemes.

### **Atmel AT93C46D 5193 Revision D (August 2007)**

Moved Pinout figure. Added new feature for Die Sales. Modified Ordering Information table layout. Modified Park Marking Schemes.

### **Atmel AT93C46D 5193 Revision C (June 2007)**

Updated to new template. Added Product Markup Scheme. Added Technical email contact. Corrected Figures 4 and 5.

**Atmel AT93C46D 5193 Revision B (February 2007)**

Added 'Ultra Thin' description to 8-lead Mini-MAP package.

**Atmel AT93C46E 5207 Revision A (January 2007)**

Initial document release.

**Atmel AT93C46D 5193 Revision A (January 2007)**

Initial document release.

## The Microchip Website

---

Microchip provides online support via our website at <http://www.microchip.com/>. This website is used to make files and information easily available to customers. Some of the content available includes:

- **Product Support** – Data sheets and errata, application notes and sample programs, design resources, user's guides and hardware support documents, latest software releases and archived software
- **General Technical Support** – Frequently Asked Questions (FAQs), technical support requests, online discussion groups, Microchip design partner program member listing
- **Business of Microchip** – Product selector and ordering guides, latest Microchip press releases, listing of seminars and events, listings of Microchip sales offices, distributors and factory representatives

## Product Change Notification Service

---

Microchip's product change notification service helps keep customers current on Microchip products. Subscribers will receive email notification whenever there are changes, updates, revisions or errata related to a specified product family or development tool of interest.

To register, go to <http://www.microchip.com/pcn> and follow the registration instructions.

## Customer Support

---

Users of Microchip products can receive assistance through several channels:

- Distributor or Representative
- Local Sales Office
- Embedded Solutions Engineer (ESE)
- Technical Support

Customers should contact their distributor, representative or ESE for support. Local sales offices are also available to help customers. A listing of sales offices and locations is included in this document.

Technical support is available through the web site at: <http://www.microchip.com/support>

## Product Identification System

To order or obtain information, e.g., on pricing or delivery, refer to the factory or the listed sales office.

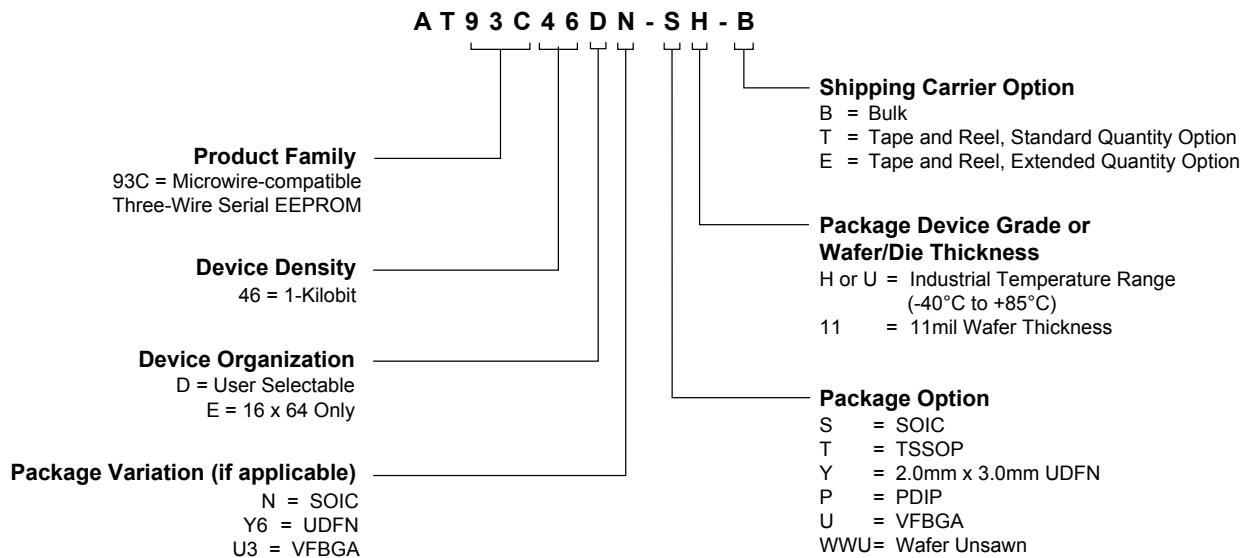

### Examples

Device	Package	Package Drawing Code	Package Option	Organization	Shipping Carrier Option	Device Grade
AT93C46DN-SH-B	SOIC	SN	S	User Selectable	Bulk (Tubes)	Industrial Temperature (-40°C to 85°C)
AT93C46EN-SH-T	SOIC	SN	S	16 X 64	Tape and Reel	
AT93C46E-TH-B	TSSOP	ST	T	16 X 64	Bulk (Tubes)	
AT93C46D-TH-T	TSSOP	ST	T	User Selectable	Tape and Reel	
AT93C46DY6-YH-T	UDFN	Q4B	Y	User Selectable	Tape and Reel	
AT93C46DY6-YH-E	UDFN	Q4B	Y	User Selectable	Extended Qty., Tape and Reel	
AT93C46E-PU	PDIP	P	P	16 X 64	Bulk (Tubes)	
AT93C46DU3-UU-T	VFBGA	8U3-1	U	User Selectable	Tape and Reel	

## Microchip Devices Code Protection Feature

Note the following details of the code protection feature on Microchip devices:

- Microchip products meet the specification contained in their particular Microchip Data Sheet.
- Microchip believes that its family of products is one of the most secure families of its kind on the market today, when used in the intended manner and under normal conditions.
- There are dishonest and possibly illegal methods used to breach the code protection feature. All of these methods, to our knowledge, require using the Microchip products in a manner outside the operating specifications contained in Microchip's Data Sheets. Most likely, the person doing so is engaged in theft of intellectual property.

- Microchip is willing to work with the customer who is concerned about the integrity of their code.
- Neither Microchip nor any other semiconductor manufacturer can guarantee the security of their code. Code protection does not mean that we are guaranteeing the product as “unbreakable.”

Code protection is constantly evolving. We at Microchip are committed to continuously improving the code protection features of our products. Attempts to break Microchip’s code protection feature may be a violation of the Digital Millennium Copyright Act. If such acts allow unauthorized access to your software or other copyrighted work, you may have a right to sue for relief under that Act.

## Legal Notice

---

Information contained in this publication regarding device applications and the like is provided only for your convenience and may be superseded by updates. It is your responsibility to ensure that your application meets with your specifications. MICROCHIP MAKES NO REPRESENTATIONS OR WARRANTIES OF ANY KIND WHETHER EXPRESS OR IMPLIED, WRITTEN OR ORAL, STATUTORY OR OTHERWISE, RELATED TO THE INFORMATION, INCLUDING BUT NOT LIMITED TO ITS CONDITION, QUALITY, PERFORMANCE, MERCHANTABILITY OR FITNESS FOR PURPOSE. Microchip disclaims all liability arising from this information and its use. Use of Microchip devices in life support and/or safety applications is entirely at the buyer’s risk, and the buyer agrees to defend, indemnify and hold harmless Microchip from any and all damages, claims, suits, or expenses resulting from such use. No licenses are conveyed, implicitly or otherwise, under any Microchip intellectual property rights unless otherwise stated.

## Trademarks

---

The Microchip name and logo, the Microchip logo, Adaptec, AnyRate, AVR, AVR logo, AVR Freaks, BesTime, BitCloud, chipKIT, chipKIT logo, CryptoMemory, CryptoRF, dsPIC, FlashFlex, flexPWR, HELDO, IGLOO, JukeBlox, KeeLoq, Klear, LANCheck, LinkMD, maXStylus, maXTouch, MediaLB, megaAVR, Microsemi, Microsemi logo, MOST, MOST logo, MPLAB, OptoLyzer, PackeTime, PIC, picoPower, PICSTART, PIC32 logo, PolarFire, Prochip Designer, QTouch, SAM-BA, SenGenuity, SpyNIC, SST, SST Logo, SuperFlash, Symmetricom, SyncServer, Tachyon, TempTrackr, TimeSource, tinyAVR, UNI/O, Vectron, and XMEGA are registered trademarks of Microchip Technology Incorporated in the U.S.A. and other countries.

APT, ClockWorks, The Embedded Control Solutions Company, EtherSynch, FlashTec, Hyper Speed Control, HyperLight Load, IntelliMOS, Libero, motorBench, mTouch, Powermite 3, Precision Edge, ProASIC, ProASIC Plus, ProASIC Plus logo, Quiet-Wire, SmartFusion, SyncWorld, Temux, TimeCesium, TimeHub, TimePictra, TimeProvider, Vite, WinPath, and ZL are registered trademarks of Microchip Technology Incorporated in the U.S.A.

Adjacent Key Suppression, AKS, Analog-for-the-Digital Age, Any Capacitor, AnyIn, AnyOut, BlueSky, BodyCom, CodeGuard, CryptoAuthentication, CryptoAutomotive, CryptoCompanion, CryptoController, dsPICDEM, dsPICDEM.net, Dynamic Average Matching, DAM, ECAN, EtherGREEN, In-Circuit Serial Programming, ICSP, INICnet, Inter-Chip Connectivity, JitterBlocker, KlearNet, KlearNet logo, memBrain, Mindi, MiWi, MPASM, MPF, MPLAB Certified logo, MPLIB, MPLINK, MultiTRAK, NetDetach, Omniscient Code Generation, PICDEM, PICDEM.net, PICKit, PICtail, PowerSmart, PureSilicon, QMatrix, REAL ICE, Ripple Blocker, SAM-ICE, Serial Quad I/O, SMART-I.S., SQI, SuperSwitcher, SuperSwitcher II, Total Endurance, TSHARC, USBCheck, VariSense, ViewSpan, WiperLock, Wireless DNA, and ZENA are trademarks of Microchip Technology Incorporated in the U.S.A. and other countries.

SQTP is a service mark of Microchip Technology Incorporated in the U.S.A.

The Adaptec logo, Frequency on Demand, Silicon Storage Technology, and Symmcom are registered trademarks of Microchip Technology Inc. in other countries.

GestIC is a registered trademark of Microchip Technology Germany II GmbH & Co. KG, a subsidiary of Microchip Technology Inc., in other countries.

All other trademarks mentioned herein are property of their respective companies.

© 2019, Microchip Technology Incorporated, Printed in the U.S.A., All Rights Reserved.

ISBN: 978-1-5224-4748-1

AMBA, Arm, Arm7, Arm7TDMI, Arm9, Arm11, Artisan, big.LITTLE, Cordio, CoreLink, CoreSight, Cortex, DesignStart, DynamIQ, Jazelle, Keil, Mali, Mbed, Mbed Enabled, NEON, POP, RealView, SecurCore, Socrates, Thumb, TrustZone, ULINK, ULINK2, ULINK-ME, ULINK-PLUS, ULINKpro,  $\mu$ Vision, Versatile are trademarks or registered trademarks of Arm Limited (or its subsidiaries) in the US and/or elsewhere.

## Quality Management System

---

For information regarding Microchip's Quality Management Systems, please visit <http://www.microchip.com/quality>.

## Worldwide Sales and Service

AMERICAS	ASIA/PACIFIC	ASIA/PACIFIC	EUROPE
<p><b>Corporate Office</b> 2355 West Chandler Blvd. Chandler, AZ 85224-6199 Tel: 480-792-7200 Fax: 480-792-7277 Technical Support: <a href="http://www.microchip.com/support">http://www.microchip.com/support</a> Web Address: <a href="http://www.microchip.com">http://www.microchip.com</a></p> <p><b>Atlanta</b> Duluth, GA Tel: 678-957-9614 Fax: 678-957-1455</p> <p><b>Austin, TX</b> Tel: 512-257-3370</p> <p><b>Boston</b> Westborough, MA Tel: 774-760-0087 Fax: 774-760-0088</p> <p><b>Chicago</b> Itasca, IL Tel: 630-285-0071 Fax: 630-285-0075</p> <p><b>Dallas</b> Addison, TX Tel: 972-818-7423 Fax: 972-818-2924</p> <p><b>Detroit</b> Novi, MI Tel: 248-848-4000</p> <p><b>Houston, TX</b> Tel: 281-894-5983</p> <p><b>Indianapolis</b> Noblesville, IN Tel: 317-773-8323 Fax: 317-773-5453 Tel: 317-536-2380</p> <p><b>Los Angeles</b> Mission Viejo, CA Tel: 949-462-9523 Fax: 949-462-9608 Tel: 951-273-7800</p> <p><b>Raleigh, NC</b> Tel: 919-844-7510</p> <p><b>New York, NY</b> Tel: 631-435-6000</p> <p><b>San Jose, CA</b> Tel: 408-735-9110 Tel: 408-436-4270</p> <p><b>Canada - Toronto</b> Tel: 905-695-1980 Fax: 905-695-2078</p>	<p><b>Australia - Sydney</b> Tel: 61-2-9868-6733</p> <p><b>China - Beijing</b> Tel: 86-10-8569-7000</p> <p><b>China - Chengdu</b> Tel: 86-28-8665-5511</p> <p><b>China - Chongqing</b> Tel: 86-23-8980-9588</p> <p><b>China - Dongguan</b> Tel: 86-769-8702-9880</p> <p><b>China - Guangzhou</b> Tel: 86-20-8755-8029</p> <p><b>China - Hangzhou</b> Tel: 86-571-8792-8115</p> <p><b>China - Hong Kong SAR</b> Tel: 852-2943-5100</p> <p><b>China - Nanjing</b> Tel: 86-25-8473-2460</p> <p><b>China - Qingdao</b> Tel: 86-532-8502-7355</p> <p><b>China - Shanghai</b> Tel: 86-21-3326-8000</p> <p><b>China - Shenyang</b> Tel: 86-24-2334-2829</p> <p><b>China - Shenzhen</b> Tel: 86-755-8864-2200</p> <p><b>China - Suzhou</b> Tel: 86-186-6233-1526</p> <p><b>China - Wuhan</b> Tel: 86-27-5980-5300</p> <p><b>China - Xian</b> Tel: 86-29-8833-7252</p> <p><b>China - Xiamen</b> Tel: 86-592-2388138</p> <p><b>China - Zhuhai</b> Tel: 86-756-3210040</p>	<p><b>India - Bangalore</b> Tel: 91-80-3090-4444</p> <p><b>India - New Delhi</b> Tel: 91-11-4160-8631</p> <p><b>India - Pune</b> Tel: 91-20-4121-0141</p> <p><b>Japan - Osaka</b> Tel: 81-6-6152-7160</p> <p><b>Japan - Tokyo</b> Tel: 81-3-6880-3770</p> <p><b>Korea - Daegu</b> Tel: 82-53-744-4301</p> <p><b>Korea - Seoul</b> Tel: 82-2-554-7200</p> <p><b>Malaysia - Kuala Lumpur</b> Tel: 60-3-7651-7906</p> <p><b>Malaysia - Penang</b> Tel: 60-4-227-8870</p> <p><b>Philippines - Manila</b> Tel: 63-2-634-9065</p> <p><b>Singapore</b> Tel: 65-6334-8870</p> <p><b>Taiwan - Hsin Chu</b> Tel: 886-3-577-8366</p> <p><b>Taiwan - Kaohsiung</b> Tel: 886-7-213-7830</p> <p><b>Taiwan - Taipei</b> Tel: 886-2-2508-8600</p> <p><b>Thailand - Bangkok</b> Tel: 66-2-694-1351</p> <p><b>Vietnam - Ho Chi Minh</b> Tel: 84-28-5448-2100</p>	<p><b>Austria - Wels</b> Tel: 43-7242-2244-39 Fax: 43-7242-2244-393</p> <p><b>Denmark - Copenhagen</b> Tel: 45-4450-2828 Fax: 45-4485-2829</p> <p><b>Finland - Espoo</b> Tel: 358-9-4520-820</p> <p><b>France - Paris</b> Tel: 33-1-69-53-63-20 Fax: 33-1-69-30-90-79</p> <p><b>Germany - Garching</b> Tel: 49-8931-9700</p> <p><b>Germany - Haan</b> Tel: 49-2129-3766400</p> <p><b>Germany - Heilbronn</b> Tel: 49-7131-72400</p> <p><b>Germany - Karlsruhe</b> Tel: 49-721-625370</p> <p><b>Germany - Munich</b> Tel: 49-89-627-144-0 Fax: 49-89-627-144-44</p> <p><b>Germany - Rosenheim</b> Tel: 49-8031-354-560</p> <p><b>Israel - Ra'anana</b> Tel: 972-9-744-7705</p> <p><b>Italy - Milan</b> Tel: 39-0331-742611 Fax: 39-0331-466781</p> <p><b>Italy - Padova</b> Tel: 39-049-7625286</p> <p><b>Netherlands - Druen</b> Tel: 31-416-690399 Fax: 31-416-690340</p> <p><b>Norway - Trondheim</b> Tel: 47-72884388</p> <p><b>Poland - Warsaw</b> Tel: 48-22-3325737</p> <p><b>Romania - Bucharest</b> Tel: 40-21-407-87-50</p> <p><b>Spain - Madrid</b> Tel: 34-91-708-08-90 Fax: 34-91-708-08-91</p> <p><b>Sweden - Gothenberg</b> Tel: 46-31-704-60-40</p> <p><b>Sweden - Stockholm</b> Tel: 46-8-5090-4654</p> <p><b>UK - Wokingham</b> Tel: 44-118-921-5800 Fax: 44-118-921-5820</p>

## Looking for pricing, stock, or lifecycle information?

Click below to explore more details on WIN SOURCE:

 [View AT93C46D-TH-B on WIN SOURCE](#)

 [Atmel Information](#)

## Optimize Your Supply Chain with WIN SOURCE Solutions

-  Global Sourcing Solution
-  Obsolete Management
-  Cost Control Management
-  Shortage Management
-  Alternative Solution
-  Excess Inventory Management