



**THE DATASHEET OF  
SN74LS293N**



# SN54290, SN54293, SN54LS290, SN54LS293 SN74290, SN74293, SN74LS290, SN74LS293 DECADE AND 4-BIT BINARY COUNTERS

SDLS097 - MARCH 1974 - REVISED MARCH 1988

'290, 'LS290 . . . DECADE COUNTERS  
'293, 'LS293 . . . 4-BIT BINARY COUNTERS

SN54290, SN54LS290, SN54293,  
SN54LS293 . . . J OR W PACKAGE  
SN74290, SN74293 . . . N PACKAGE  
SN74LS290, SN74LS293 . . . D OR N PACKAGE  
(TOP VIEW)

- GND and VCC on Corner Pins  
(Pins 7 and 14 Respectively)

## description

The SN54290/SN74290, SN54LS290/SN74LS290, SN54293/SN74293, and SN54LS293/SN74LS293 counters are electrically and functionally identical to the SN5490A/SN7490A, SN54LS90/SN74LS90, SN5493A/SN7493A, and SN54LS93/SN74LS93, respectively. Only the arrangement of the terminals has been changed for the '290, 'LS290, '293, and 'LS293.

Each of these monolithic counters contains four master-slave flip-flops and additional gating to provide a divide-by-two counter and a three-stage binary counter for which the count cycle length is divide-by-five for the '290 and 'LS290 and divide-by-eight for the '293 and 'LS293.

All of these counters have a gated zero reset and the '290 and 'LS290 also have gated set-to-nine inputs for use in BCD nine's complement applications.

To use the maximum count length (decade or four-bit binary) of these counters, the B input is connected to the Q<sub>A</sub> output. The input count pulses are applied to input A and the outputs are as described in the appropriate function table. A symmetrical divide-by-ten count can be obtained from the '290 and 'LS290 counters by connecting the Q<sub>D</sub> output to the A input and applying the input count to the B input which gives a divide-by-ten square wave at output Q<sub>A</sub>.

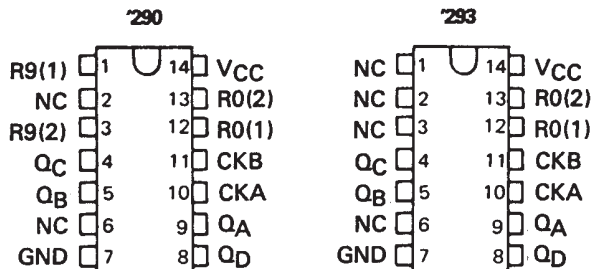

SN54LS290, SN54LS293 . . . FK PACKAGE  
(TOP VIEW)

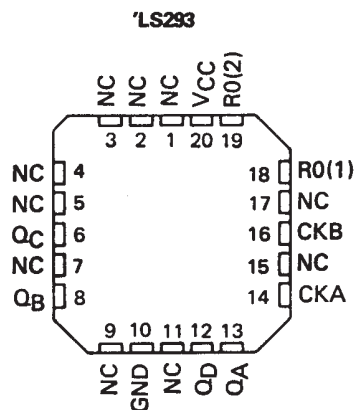
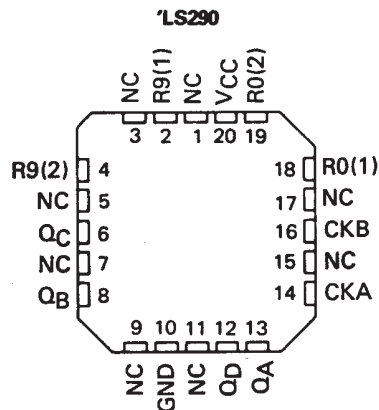

NC - No internal connection

SN54290, SN54293, SN54LS290, SN54LS293  
 SN74290, SN74293, SN74LS290, SN74LS293  
 DECADE AND 4-BIT BINARY COUNTERS

SDLS097 – MARCH 1974 – REVISED MARCH 1988

logic symbols†

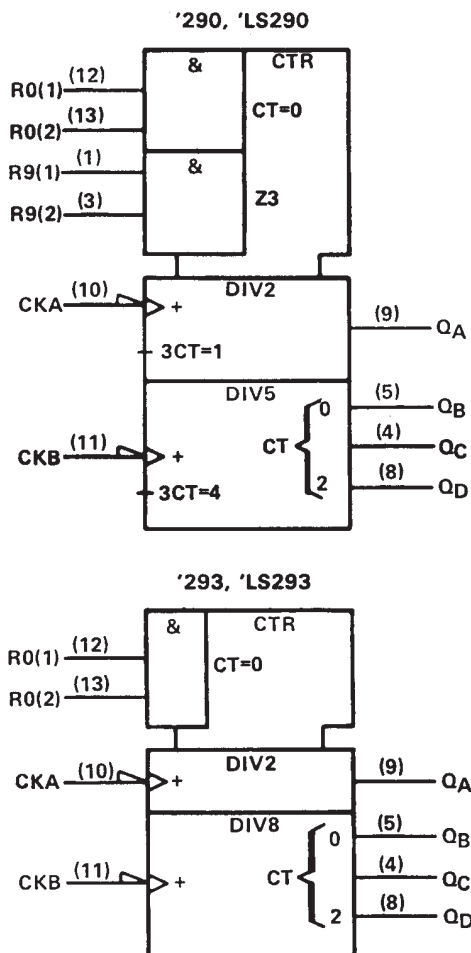

† These symbols are in accordance with ANSI/IEEE Std 91-1984 and IEC Publication 617-12. Pin numbers shown are for D, J, N, and W packages.

# SN54290, SN54293, SN54LS290, SN54LS293 SN74290, SN74293, SN74LS290, SN74LS293 DECADE AND 4-BIT BINARY COUNTERS

SDLS097 - MARCH 1974 - REVISED MARCH 1988

'290, 'LS290  
BCD COUNT SEQUENCE  
(See Note A)

COUNT	OUTPUT			
	Q <sub>D</sub>	Q <sub>C</sub>	Q <sub>B</sub>	Q <sub>A</sub>
0	L	L	L	L
1	L	L	L	H
2	L	L	H	L
3	L	L	H	H
4	L	H	L	L
5	L	H	L	H
6	L	H	H	L
7	L	H	H	H
8	H	L	L	L
9	H	L	L	H

'290, 'LS290  
BI-QUINARY (5-2)  
(See Note B)

COUNT	OUTPUT			
	Q <sub>A</sub>	Q <sub>D</sub>	Q <sub>C</sub>	Q <sub>B</sub>
0	L	L	L	L
1	L	L	L	H
2	L	L	H	L
3	L	L	H	H
4	L	H	L	L
5	H	L	L	L
6	H	L	L	H
7	H	L	H	L
8	H	L	H	H
9	H	H	L	L

'290, 'LS290  
RESET/COUNT FUNCTION TABLE

RESET INPUTS				OUTPUT			
R <sub>0</sub> (1)	R <sub>0</sub> (2)	R <sub>9</sub> (1)	R <sub>9</sub> (2)	Q <sub>D</sub>	Q <sub>C</sub>	Q <sub>B</sub>	Q <sub>A</sub>
H	H	L	X	L	L	L	L
H	H	X	L	L	L	L	L
X	X	H	H	H	L	L	H
X	L	X	L	COUNT			
L	X	L	X	COUNT			
L	X	X	L	COUNT			
X	L	L	X	COUNT			

'293, 'LS293  
COUNT SEQUENCE  
(See Note C)

COUNT	OUTPUT			
	Q <sub>D</sub>	Q <sub>C</sub>	Q <sub>B</sub>	Q <sub>A</sub>
0	L	L	L	L
1	L	L	L	H
2	L	L	H	L
3	L	L	H	H
4	L	H	L	L
5	L	H	L	H
6	L	H	H	L
7	L	H	H	H
8	H	L	L	L
9	H	L	L	H
10	H	L	H	L
11	H	L	H	H
12	H	H	L	L
13	H	H	L	H
14	H	H	H	L
15	H	H	H	H

- NOTES: A. Output Q<sub>A</sub> is connected to input B for BCD count.  
 B. Output Q<sub>D</sub> is connected to input A for bi-quinary count.  
 C. Output Q<sub>A</sub> is connected to input B.  
 D. H = high level, L = low level, X = irrelevant

'293, 'LS293  
RESET/COUNT FUNCTION TABLE

RESET INPUTS		OUTPUT			
R <sub>0</sub> (1)	R <sub>0</sub> (2)	Q <sub>D</sub>	Q <sub>C</sub>	Q <sub>B</sub>	Q <sub>A</sub>
H	H	L	L	L	L
L	X	COUNT			
X	L	COUNT			

## logic diagrams (positive logic)

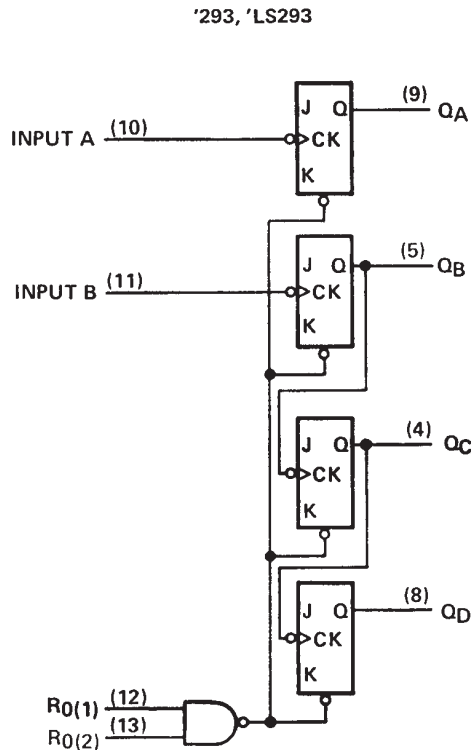
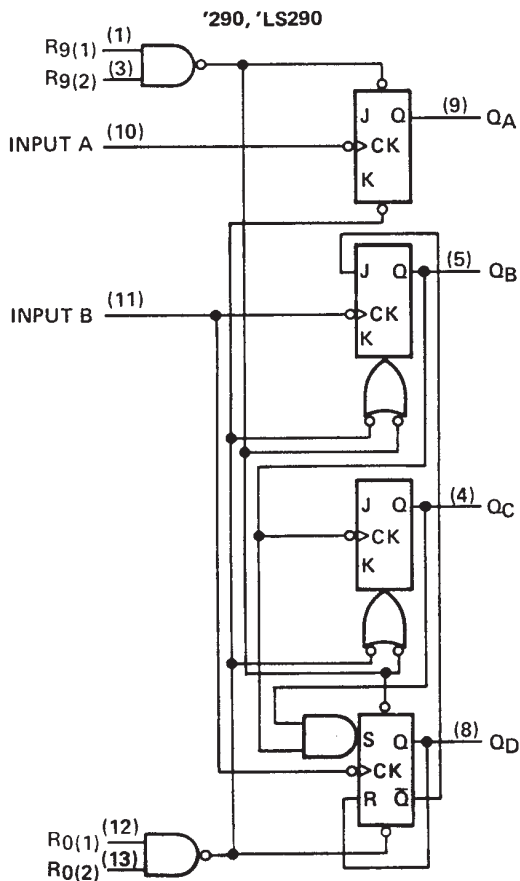

Pin numbers shown are for D, J, N, and W packages.

The J and K inputs shown without connection are for reference only and are functionally at a high level.

# SN54290, SN54293, SN54LS290, SN54LS293 SN74290, SN74293, SN74LS290, SN74LS293 DECADE AND 4-BIT BINARY COUNTERS

SDLS097 – MARCH 1974 – REVISED MARCH 1988

## schematics of inputs and outputs

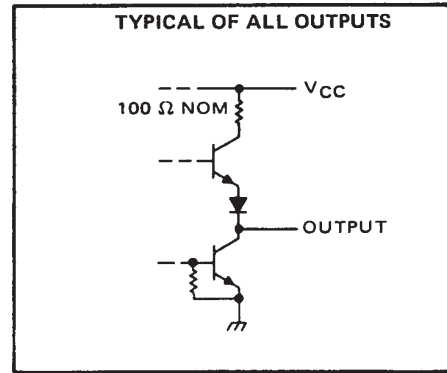
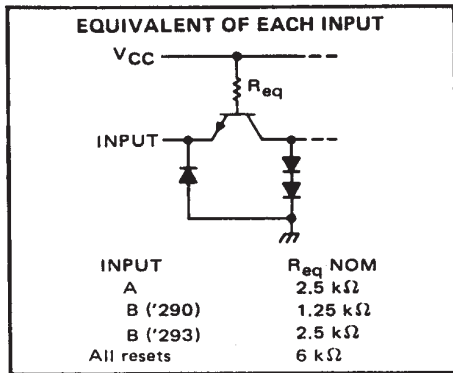

## absolute maximum ratings over operating free-air temperature range (unless otherwise noted)

Supply voltage, $V_{CC}$ (see Note 1)	7 V
Input voltage	5.5 V
Interemitter voltage (see Note 2)	5.5 V
Operating free-air temperature range: SN54' Circuits	-55°C to 125°C
SN74' Circuits	0°C to 70°C
Storage temperature range	-65°C to 150°C

- NOTES: 1. Voltage values, except interemitter voltage, are with respect to network ground terminal.  
2. This is the voltage between two emitters of a multiple-emitter transistor. For these circuits, this rating applies between the two  $R_0$  inputs, and for the '290 circuit, it also applies between the two  $R_9$  inputs.

## recommended operating conditions

	SN54'			SN74'			UNIT
	MIN	NOM	MAX	MIN	NOM	MAX	
Supply voltage, $V_{CC}$	4.5	5	5.5	4.75	5	5.25	V
High-level output current, $I_{OH}$			-800			-800	$\mu$ A
Low-level output current, $I_{OL}$			16			16	mA
Count frequency, $f_{count}$	A input	0	32	0	32		MHz
	B input	0	16	0	16		
Pulse width, $t_w$	A input	15		15			ns
	B input	30		30			
	Reset inputs	15		15			
Reset inactive-state setup time, $t_{su}$	25			25			ns
Operating free-air temperature, $T_A$	-55		125	0		70	°C

SN54290, SN54293, SN54LS290, SN54LS293  
 SN74290, SN74293, SN74LS290, SN74LS293  
 DECADE AND 4-BIT BINARY COUNTERS

SDLS097 - MARCH 1974 - REVISED MARCH 1988

electrical characteristics over recommended operating free-air temperature range (unless otherwise noted)

PARAMETER	TEST CONDITIONS†	'290			'293			UNIT		
		MIN	TYP‡	MAX	MIN	TYP‡	MAX			
V <sub>IH</sub> High-level input voltage		2			2			V		
V <sub>IL</sub> Low-level input voltage				0.8			0.8	V		
V <sub>IK</sub> Input clamp voltage	V <sub>CC</sub> = MIN, I <sub>I</sub> = -12 mA			-1.5			-1.5	V		
V <sub>OH</sub> High-level output voltage	V <sub>CC</sub> = MIN, V <sub>IH</sub> = 2 V, V <sub>IL</sub> = 0.8 V, I <sub>OH</sub> = -800 μA	2.4	3.4		2.4	3.4		V		
V <sub>OL</sub> Low-level output voltage	V <sub>CC</sub> = MIN, V <sub>IH</sub> = 2 V, V <sub>IL</sub> = 0.8 V, I <sub>OL</sub> = 16 mA¶		0.2	0.4		0.2	0.4	V		
I <sub>I</sub> Input current at maximum input voltage	V <sub>CC</sub> = MAX, V <sub>I</sub> = 5.5 V			1			1	mA		
I <sub>IH</sub> High-level input current	Any reset			40			40	μA		
	A input	V <sub>CC</sub> = MAX, V <sub>I</sub> = 2.4 V							80	
	B input								120	80
I <sub>IL</sub> Low-level input current	Any reset	V <sub>CC</sub> = MAX, V <sub>I</sub> = 0.4 V						-1.6	mA	
	A input							-3.2		-3.2
	B input							-4.8		-3.2
I <sub>OS</sub> Short-circuit output current§	V <sub>CC</sub> = MAX	SN54'	-20	-57	-20	-57	mA			
		SN74'	-18	-57	-18	-57				
I <sub>CC</sub> Supply current	V <sub>CC</sub> = MAX, See Note 3		29	42		26	39	mA		

† For conditions shown as MIN or MAX, use the appropriate value specified under recommended operating conditions.

‡ All typical values are at V<sub>CC</sub> = 5 V, T<sub>A</sub> = 25°C.

§ Not more than one output should be shorted at a time.

¶ Q<sub>A</sub> outputs are tested at I<sub>OL</sub> = 16 mA plus the limit value of I<sub>IL</sub> for the B input. This permits driving the B input while maintaining full fan-out capability.

NOTE 3: I<sub>CC</sub> is measured with all outputs open, both R<sub>0</sub> inputs grounded following momentary connection to 4.5 V, and all other inputs grounded.

switching characteristics, V<sub>CC</sub> = 5 V, T<sub>A</sub> = 25°C

PARAMETER#	FROM (INPUT)	TO (OUTPUT)	TEST CONDITIONS	'290			'293			UNIT
				MIN	TYP	MAX	MIN	TYP	MAX	
f <sub>max</sub>	A	Q <sub>A</sub>	C <sub>L</sub> = 15 pF, R <sub>L</sub> = 400 Ω, See Note 4	32	42		32	42	MHz	
	B	Q <sub>B</sub>		16			16			
t <sub>PLH</sub>	A	Q <sub>A</sub>		10	16		10	16	ns	
t <sub>PHL</sub>				12	18		12	18		
t <sub>PLH</sub>	A	Q <sub>D</sub>		32	48		46	70	ns	
t <sub>PHL</sub>				34	50		46	70		
t <sub>PLH</sub>	B	Q <sub>B</sub>		10	16		10	16	ns	
t <sub>PHL</sub>				14	21		14	21		
t <sub>PLH</sub>	B	Q <sub>C</sub>		21	32		21	32	ns	
t <sub>PHL</sub>				23	35		23	35		
t <sub>PLH</sub>	B	Q <sub>D</sub>		21	32		34	51	ns	
t <sub>PHL</sub>				23	35		34	51		
t <sub>PHL</sub>	Set-to-0	Any		26	40		26	40	ns	
t <sub>PLH</sub>	Set-to-9	Q <sub>A</sub> , Q <sub>D</sub>		20	30				ns	
t <sub>PHL</sub>		Q <sub>B</sub> , Q <sub>C</sub>		26	40					

# f<sub>max</sub> = maximum count frequency

t<sub>PLH</sub> = propagation delay time, low-to-high-level output

t<sub>PHL</sub> = propagation delay time, high-to-low-level output

NOTE 4: Load circuits and voltage waveforms are shown in Section 1.





SN54290, SN54293, SN54LS290, SN54LS293  
 SN74290, SN74293, SN74LS290, SN74LS293  
 DECADE AND 4-BIT BINARY COUNTERS

SDLS097 - MARCH 1974 - REVISED MARCH 1988

electrical characteristics over recommended operating free-air temperature range (unless otherwise noted)

PARAMETER		TEST CONDITIONS†	SN54LS'			SN74LS'			UNIT
			MIN	TYP‡	MAX	MIN	TYP‡	MAX	
V <sub>IH</sub>	High-level input voltage		2			2			V
V <sub>IL</sub>	Low-level input voltage				0.7			0.8	V
V <sub>IK</sub>	Input clamp voltage	V <sub>CC</sub> = MIN, I <sub>I</sub> = -18 mA			-1.5			-1.5	V
V <sub>OH</sub>	High-level output voltage	V <sub>CC</sub> = MIN, V <sub>IH</sub> = 2 V, V <sub>IL</sub> = V <sub>IL</sub> max, I <sub>OH</sub> = -400 µA	2.5	3.4		2.7	3.4		V
V <sub>OL</sub>	Low-level output voltage	V <sub>CC</sub> = MIN, V <sub>IH</sub> = 2 V, V <sub>IL</sub> = V <sub>IL</sub> max	I <sub>OL</sub> = 4 mA¶		0.25	0.4	0.25 0.4		V
			I <sub>OL</sub> = 8 mA¶				0.35	0.5	
I <sub>I</sub>	Input current at maximum input voltage	Any reset	V <sub>CC</sub> = MAX, V <sub>I</sub> = 7 V			0.1 0.1			mA
		A input				0.2 0.2			
		B of 'LS290	V <sub>CC</sub> = MAX, V <sub>I</sub> = 5.5 V			0.4 0.4			
		B of 'LS293				0.2 0.2			
I <sub>IH</sub>	High-level input current	Any reset	V <sub>CC</sub> = MAX, V <sub>I</sub> = 2.7 V			20 20			µA
		A input				40 40			
		B of 'LS290				80 80			
		B of 'LS293				40 40			
I <sub>IL</sub>	Low-level input current	Any reset	V <sub>CC</sub> = MAX, V <sub>I</sub> = 0.4 V			-0.4 -0.4			mA
		A input				-2.4 -2.4			
		B of 'LS290				-3.2 -3.2			
		B of 'LS293				-1.6 -1.6			
I <sub>OS</sub>	Short-circuit output current§	V <sub>CC</sub> = MAX	-20	-100	-20	-100			mA
I <sub>CC</sub>	Supply current	V <sub>CC</sub> = MAX, See Note 3	'LS290		9	15	9 15		mA
			'LS293		9	15	9 15		

† For conditions shown as MIN or MAX, use the appropriate value specified under recommended operating conditions.

‡ All typical values are at V<sub>CC</sub> = 5 V, T<sub>A</sub> = 25°C.

§ Not more than one output should be shorted at a time, and duration of the short-circuit should not exceed one second.

¶ Q<sub>A</sub> outputs are tested at specified I<sub>OL</sub> plus the limit value of I<sub>IL</sub> for the B input. This permits driving the B input while maintaining full fan-out capability.

NOTE 3: I<sub>CC</sub> is measured with all outputs open, both R<sub>0</sub> inputs grounded following momentary connection to 4.5 V, and all other inputs grounded.

switching characteristics, V<sub>CC</sub> = 5 V, T<sub>A</sub> = 25°C

PARAMETER#	FROM (INPUT)	TO (OUTPUT)	TEST CONDITIONS	'LS290			'LS293			UNIT
				MIN	TYP	MAX	MIN	TYP	MAX	
f <sub>max</sub>	A	Q <sub>A</sub>	C <sub>L</sub> = 15 pF, R <sub>L</sub> = 2 kΩ, See Note 4	32	42		32	42	MHz	
	B	Q <sub>B</sub>		16			16			
t <sub>PLH</sub>	A	Q <sub>A</sub>		10	16		10	16	ns	
t <sub>PHL</sub>				12	18		12	18		
t <sub>PLH</sub>	A	Q <sub>D</sub>		32	48		46	70	ns	
t <sub>PHL</sub>				34	50		46	70		
t <sub>PLH</sub>	B	Q <sub>B</sub>		10	16		10	16	ns	
t <sub>PHL</sub>				14	21		14	21		
t <sub>PLH</sub>	B	Q <sub>C</sub>		21	32		21	32	ns	
t <sub>PHL</sub>				23	35		23	35		
t <sub>PLH</sub>	B	Q <sub>D</sub>		21	32		34	51	ns	
t <sub>PHL</sub>				23	35		34	51		
t <sub>PHL</sub>	Set-to-0	Any		26	40		26	40	ns	
t <sub>PLH</sub>	Set-to-9	Q <sub>A</sub> , Q <sub>D</sub>		20	30				ns	
t <sub>PHL</sub>		Q <sub>B</sub> , Q <sub>C</sub>	26	40						

#f<sub>max</sub> = maximum count frequency

t<sub>PLH</sub> = propagation delay time, low-to-high-level output

t<sub>PHL</sub> = propagation delay time, high-to-low-level output

NOTE 4: Load circuits and voltage waveforms are shown in Section 1.



**TAPE AND REEL INFORMATION**

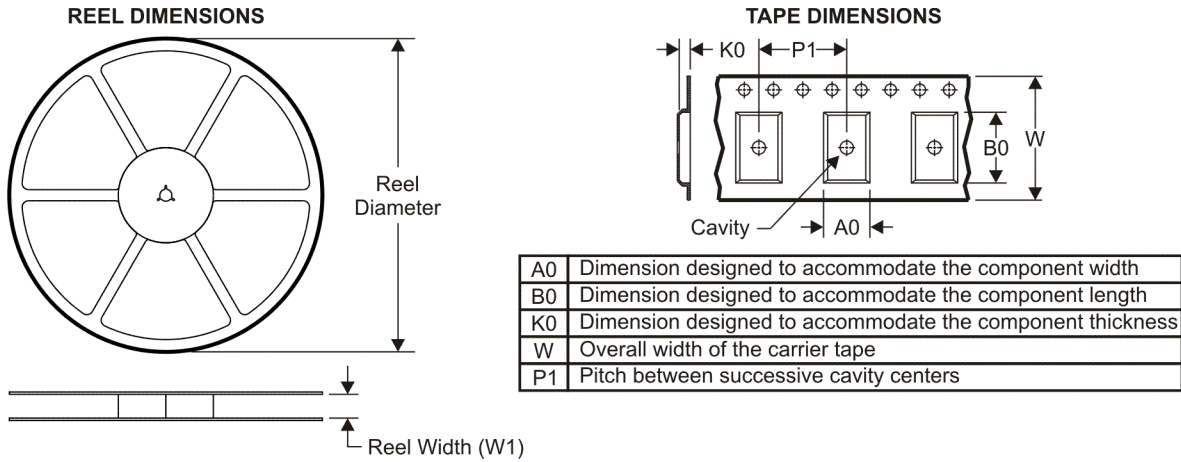

**QUADRANT ASSIGNMENTS FOR PIN 1 ORIENTATION IN TAPE**



\*All dimensions are nominal

Device	Package Type	Package Drawing	Pins	SPQ	Reel Diameter (mm)	Reel Width W1 (mm)	A0 (mm)	B0 (mm)	K0 (mm)	P1 (mm)	W (mm)	Pin1 Quadrant
SN74LS293DR	SOIC	D	14	2500	330.0	16.4	6.5	9.0	2.1	8.0	16.0	Q1

**TAPE AND REEL BOX DIMENSIONS**



\*All dimensions are nominal

Device	Package Type	Package Drawing	Pins	SPQ	Length (mm)	Width (mm)	Height (mm)
SN74LS293DR	SOIC	D	14	2500	346.0	346.0	33.0

## IMPORTANT NOTICE

Texas Instruments Incorporated and its subsidiaries (TI) reserve the right to make corrections, modifications, enhancements, improvements, and other changes to its products and services at any time and to discontinue any product or service without notice. Customers should obtain the latest relevant information before placing orders and should verify that such information is current and complete. All products are sold subject to TI's terms and conditions of sale supplied at the time of order acknowledgment.

TI warrants performance of its hardware products to the specifications applicable at the time of sale in accordance with TI's standard warranty. Testing and other quality control techniques are used to the extent TI deems necessary to support this warranty. Except where mandated by government requirements, testing of all parameters of each product is not necessarily performed.

TI assumes no liability for applications assistance or customer product design. Customers are responsible for their products and applications using TI components. To minimize the risks associated with customer products and applications, customers should provide adequate design and operating safeguards.

TI does not warrant or represent that any license, either express or implied, is granted under any TI patent right, copyright, mask work right, or other TI intellectual property right relating to any combination, machine, or process in which TI products or services are used. Information published by TI regarding third-party products or services does not constitute a license from TI to use such products or services or a warranty or endorsement thereof. Use of such information may require a license from a third party under the patents or other intellectual property of the third party, or a license from TI under the patents or other intellectual property of TI.

Reproduction of TI information in TI data books or data sheets is permissible only if reproduction is without alteration and is accompanied by all associated warranties, conditions, limitations, and notices. Reproduction of this information with alteration is an unfair and deceptive business practice. TI is not responsible or liable for such altered documentation. Information of third parties may be subject to additional restrictions.

Resale of TI products or services with statements different from or beyond the parameters stated by TI for that product or service voids all express and any implied warranties for the associated TI product or service and is an unfair and deceptive business practice. TI is not responsible or liable for any such statements.

TI products are not authorized for use in safety-critical applications (such as life support) where a failure of the TI product would reasonably be expected to cause severe personal injury or death, unless officers of the parties have executed an agreement specifically governing such use. Buyers represent that they have all necessary expertise in the safety and regulatory ramifications of their applications, and acknowledge and agree that they are solely responsible for all legal, regulatory and safety-related requirements concerning their products and any use of TI products in such safety-critical applications, notwithstanding any applications-related information or support that may be provided by TI. Further, Buyers must fully indemnify TI and its representatives against any damages arising out of the use of TI products in such safety-critical applications.

TI products are neither designed nor intended for use in military/aerospace applications or environments unless the TI products are specifically designated by TI as military-grade or "enhanced plastic." Only products designated by TI as military-grade meet military specifications. Buyers acknowledge and agree that any such use of TI products which TI has not designated as military-grade is solely at the Buyer's risk, and that they are solely responsible for compliance with all legal and regulatory requirements in connection with such use.

TI products are neither designed nor intended for use in automotive applications or environments unless the specific TI products are designated by TI as compliant with ISO/TS 16949 requirements. Buyers acknowledge and agree that, if they use any non-designated products in automotive applications, TI will not be responsible for any failure to meet such requirements.

Following are URLs where you can obtain information on other Texas Instruments products and application solutions:

### Products

Amplifiers	<a href="http://amplifier.ti.com">amplifier.ti.com</a>
Data Converters	<a href="http://dataconverter.ti.com">dataconverter.ti.com</a>
DLP® Products	<a href="http://www.dlp.com">www.dlp.com</a>
DSP	<a href="http://dsp.ti.com">dsp.ti.com</a>
Clocks and Timers	<a href="http://www.ti.com/clocks">www.ti.com/clocks</a>
Interface	<a href="http://interface.ti.com">interface.ti.com</a>
Logic	<a href="http://logic.ti.com">logic.ti.com</a>
Power Mgmt	<a href="http://power.ti.com">power.ti.com</a>
Microcontrollers	<a href="http://microcontroller.ti.com">microcontroller.ti.com</a>
RFID	<a href="http://www.ti-rfid.com">www.ti-rfid.com</a>
RF/IF and ZigBee® Solutions	<a href="http://www.ti.com/lprf">www.ti.com/lprf</a>

### Applications

Audio	<a href="http://www.ti.com/audio">www.ti.com/audio</a>
Automotive	<a href="http://www.ti.com/automotive">www.ti.com/automotive</a>
Broadband	<a href="http://www.ti.com/broadband">www.ti.com/broadband</a>
Digital Control	<a href="http://www.ti.com/digitalcontrol">www.ti.com/digitalcontrol</a>
Medical	<a href="http://www.ti.com/medical">www.ti.com/medical</a>
Military	<a href="http://www.ti.com/military">www.ti.com/military</a>
Optical Networking	<a href="http://www.ti.com/opticalnetwork">www.ti.com/opticalnetwork</a>
Security	<a href="http://www.ti.com/security">www.ti.com/security</a>
Telephony	<a href="http://www.ti.com/telephony">www.ti.com/telephony</a>
Video & Imaging	<a href="http://www.ti.com/video">www.ti.com/video</a>
Wireless	<a href="http://www.ti.com/wireless">www.ti.com/wireless</a>

Mailing Address: Texas Instruments, Post Office Box 655303, Dallas, Texas 75265  
Copyright © 2009, Texas Instruments Incorporated

## Looking for pricing, stock, or lifecycle information?

Click below to explore more details on WIN SOURCE:

 [View SN74LS293N on WIN SOURCE](#)

 [Texas Instruments](#) Information

## Optimize Your Supply Chain with WIN SOURCE Solutions

-  Global Sourcing Solution
-  Obsolete Management
-  Cost Control Management
-  Shortage Management
-  Alternative Solution
-  Excess Inventory Management