

DATA SHEET

For a complete data sheet, please also download:

- The IC06 74HC/HCT/HCU/HCMOS Logic Family Specifications
- The IC06 74HC/HCT/HCU/HCMOS Logic Package Information
- The IC06 74HC/HCT/HCU/HCMOS Logic Package Outlines

74HC/HCT4016 Quad bilateral switches

Product specification
File under Integrated Circuits, IC06

December 1990

Quad bilateral switches

74HC/HCT4016

FEATURES

- Low “ON” resistance:
160 Ω (typ.) at $V_{CC} = 4.5$ V
120 Ω (typ.) at $V_{CC} = 6.0$ V
80 Ω (typ.) at $V_{CC} = 9.0$ V
- Individual switch controls
- Typical “break before make” built in
- Output capability: non-standard
- I_{CC} category: SSI

GENERAL DESCRIPTION

The 74HC/HCT4016 are high-speed Si-gate CMOS devices and are pin compatible with the “4016” of the

“4000B” series. They are specified in compliance with JEDEC standard no. 7A.

The 74HC/HCT4016 have four independent analog switches (transmission gates).

Each switch has two input/output terminals (Y_n , Z_n) and an active HIGH enable input (E_n). When E_n is connected to V_{CC} , a low bidirectional path between Y_n and Z_n is established (ON condition). When E_n is connected to ground (GND), the switch is disabled and a high impedance between Y_n and Z_n is established (OFF condition).

Current through a switch will not cause additional V_{CC} current provided the voltage at the terminals of the switch is maintained within the supply voltage range; $V_{CC} \gg (V_Y, V_Z) \gg$ GND. Inputs Y_n and Z_n are electrically equivalent terminals.

QUICK REFERENCE DATA

GND = 0 V; $T_{amb} = 25$ °C; $t_r = t_f = 6$ ns

| SYMBOL | PARAMETER | CONDITIONS | TYPICAL | | UNIT |
|-------------------|--|---|---------|-----|------|
| | | | HC | HCT | |
| t_{PZH}/t_{PZL} | turn “ON” time E_n to V_{OS} | $C_L = 15$ pF; $R_L = 1$ k Ω ; $V_{CC} = 5$ V | 16 | 17 | ns |
| t_{PHZ}/t_{PLZ} | turn “OFF” time E_n to V_{OS} | | 14 | 20 | ns |
| C_I | input capacitance | | 3.5 | 3.5 | pF |
| C_{PD} | power dissipation capacitance per switch | notes 1 and 2 | 12 | 12 | pF |
| C_S | max. switch capacitance | | 5 | 5 | pF |

Notes

1. C_{PD} is used to determine the dynamic power dissipation (P_D in μ W):

$$P_D = C_{PD} \times V_{CC}^2 \times f_i + \sum \{ (C_L + C_S) \times V_{CC}^2 \times f_o \} \text{ where:}$$

f_i = input frequency in MHz

f_o = output frequency in MHz

$\sum \{ (C_L + C_S) \times V_{CC}^2 \times f_o \}$ = sum of outputs

C_L = output load capacitance in pF

C_S = max. switch capacitance in pF

V_{CC} = supply voltage in V

2. For HC the condition is $V_I =$ GND to V_{CC}
For HCT the condition is $V_I =$ GND to $V_{CC} - 1.5$ V

ORDERING INFORMATION

See “74HC/HCT/HCU/HCMOS Logic Package Information”.

Quad bilateral switches

74HC/HCT4016

PIN DESCRIPTION

| PIN NO. | SYMBOL | NAME AND FUNCTION |
|--------------|----------------------------------|-----------------------------|
| 1, 4, 8, 11 | Y ₀ to Y ₃ | independent inputs/outputs |
| 7 | GND | ground (0 V) |
| 2, 3, 9, 10 | Z ₀ to Z ₃ | independent inputs/outputs |
| 13, 5, 6, 12 | E ₀ to E ₃ | enable inputs (active HIGH) |
| 14 | V _{CC} | positive supply voltage |

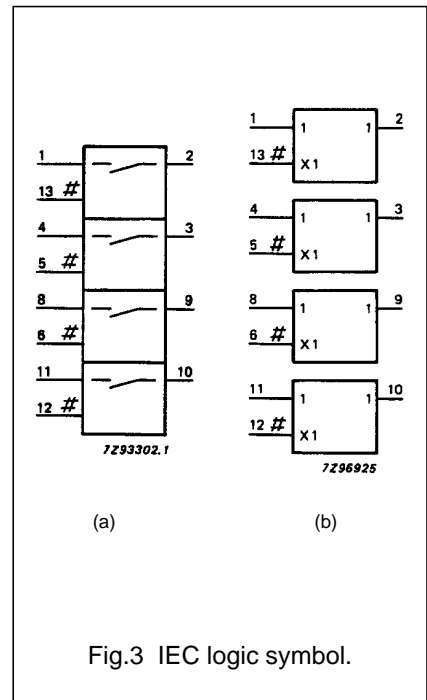
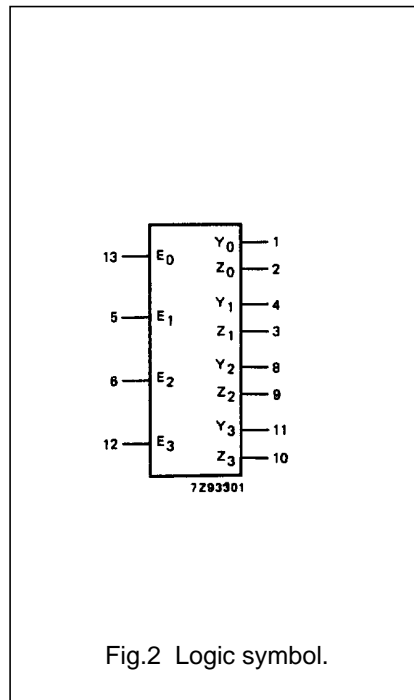
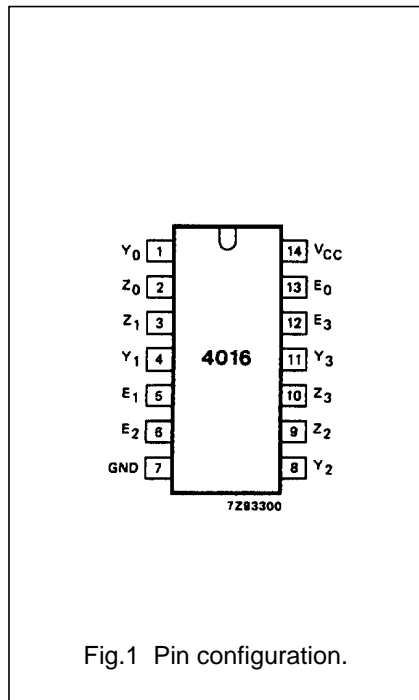

Quad bilateral switches

74HC/HCT4016

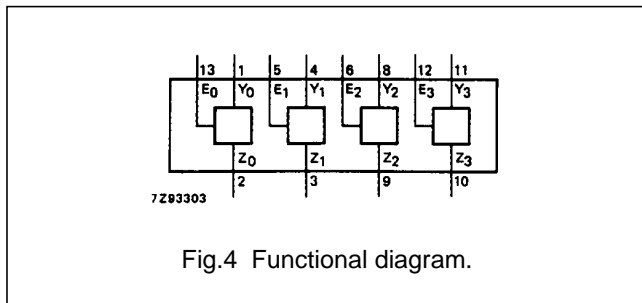

Fig.4 Functional diagram.

APPLICATIONS

- Signal gating
- Modulation
- Demodulation
- Chopper

FUNCTION TABLE

| INPUT E _n | CHANNEL IMPEDANCE |
|-------------------------|----------------------|
| L | high |
| H | low |

Notes

1. H = HIGH voltage level
L = LOW voltage level

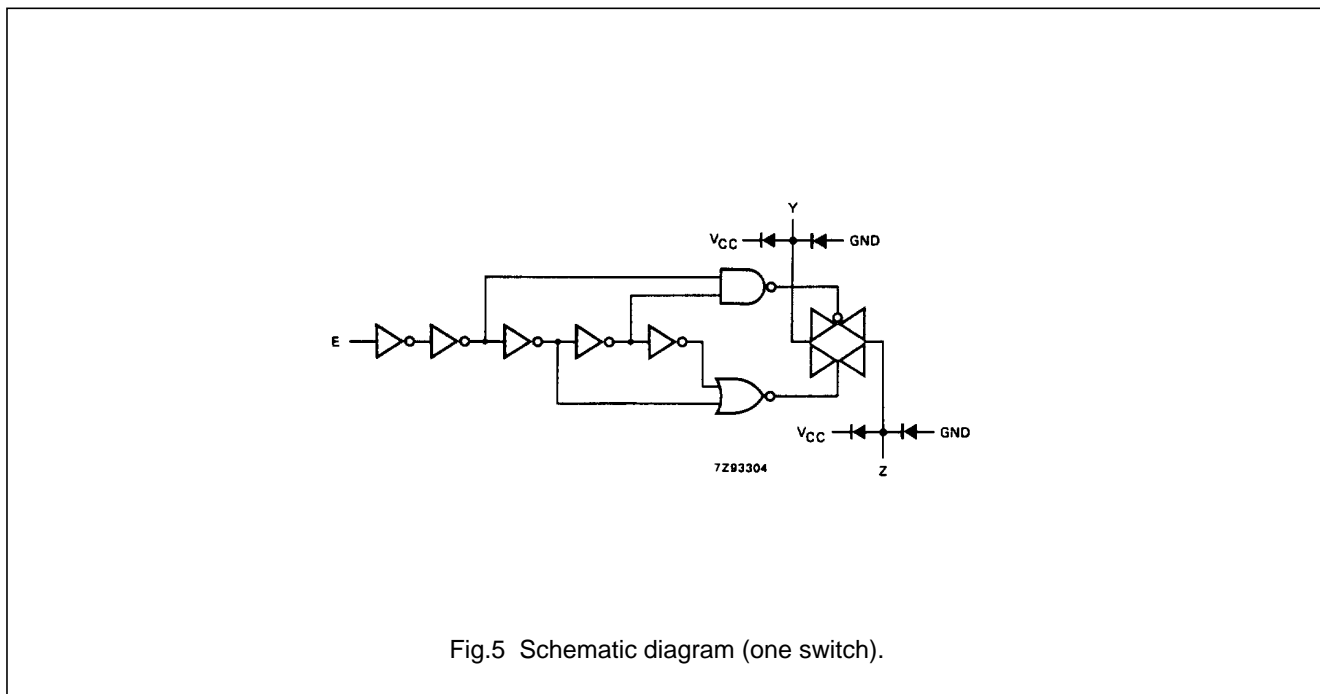

Fig.5 Schematic diagram (one switch).

Quad bilateral switches

74HC/HCT4016

RATINGS

Limiting values in accordance with the Absolute Maximum System (IEC 134)

Voltages are referenced to GND (ground = 0 V)

| SYMBOL | PARAMETER | MIN. | MAX. | UNIT | CONDITIONS |
|---------------------------|--------------------------------|------|-------|------|---|
| V_{CC} | DC supply voltage | -0.5 | +11.0 | V | |
| $\pm I_{IK}$ | DC digital input diode current | | 20 | mA | for $V_I < -0.5$ V or $V_I > V_{CC} + 0.5$ V |
| $\pm I_{SK}$ | DC switch diode current | | 20 | mA | for $V_S < -0.5$ V or $V_S > V_{CC} + 0.5$ V |
| $\pm I_S$ | DC switch current | | 25 | mA | for -0.5 V $< V_S < V_{CC} + 0.5$ V |
| $\pm I_{CC}; \pm I_{GND}$ | DC V_{CC} or GND current | | 50 | mA | |
| T_{stg} | storage temperature range | -65 | +150 | °C | |
| P_{tot} | power dissipation per package | | | | for temperature range: -40 to +125 °C 74HC/HCT |
| | plastic DIL | | 750 | mW | above +70 °C: derate linearly with 12 mW/K |
| | plastic mini-pack (SO) | | 500 | mW | above +70 °C: derate linearly with 8 mW/K |
| P_S | power dissipation per switch | | 100 | mW | |

RECOMMENDED OPERATING CONDITIONS

| SYMBOL | PARAMETER | 74HC | | | 74HCT | | | UNIT | CONDITIONS |
|------------|-------------------------------------|------|------|---------------------------|-------|------|----------|------|---|
| | | min. | typ. | max. | min. | typ. | max. | | |
| V_{CC} | DC supply voltage | 2.0 | 5.0 | 10.0 | 4.5 | 5.0 | 5.5 | V | |
| V_I | DC input voltage range | GND | | V_{CC} | GND | | V_{CC} | V | |
| V_S | DC switch voltage range | GND | | V_{CC} | GND | | V_{CC} | V | |
| T_{amb} | operating ambient temperature range | -40 | | +85 | -40 | | +85 | °C | see DC and AC CHARACTERISTICS |
| T_{amb} | operating ambient temperature range | -40 | | +125 | -40 | | +125 | °C | |
| t_r, t_f | input rise and fall times | | 6.0 | 1000 500 400 250 | | 6.0 | 500 | ns | $V_{CC} = 2.0$ V $V_{CC} = 4.5$ V $V_{CC} = 6.0$ V $V_{CC} = 10.0$ V |

Quad bilateral switches

74HC/HCT4016

DC CHARACTERISTICS FOR 74HC/HCT

For 74HC: $V_{CC} = 2.0, 4.5, 6.0$ and 9.0 V

For 74HCT: $V_{CC} = 4.5$ V

| SYMBOL | PARAMETER | T_{amb} (°C) | | | | | | UNIT | TEST CONDITIONS | | | | |
|-----------------|---|----------------|------|------|------------|------|-------------|------|-----------------|---------------------|----------|-----------------------|----------------------------|
| | | 74HC/HCT | | | | | | | V_{CC} (V) | I_S (μ A) | V_{is} | V_I | |
| | | +25 | | | -40 to +85 | | -40 to +125 | | | | | | |
| | | min. | typ. | max. | min. | max. | min. | | | | | | max. |
| R_{ON} | ON resistance (peak) | | - | - | | - | | - | Ω | 2.0 | 100 | V_{CC} to GND | V_{IH} or V_{IL} |
| | | | 160 | 320 | | 400 | | 480 | Ω | 4.5 | 1000 | | |
| | | | 120 | 240 | | 300 | | 360 | Ω | 6.0 | 1000 | | |
| | | | 85 | 170 | | 213 | | 255 | Ω | 9.0 | 1000 | | |
| R_{ON} | ON resistance (rail) | | 160 | - | | - | | - | Ω | 2.0 | 100 | GND | V_{IH} or V_{IL} |
| | | | 80 | 160 | | 200 | | 240 | Ω | 4.5 | 1000 | | |
| | | | 70 | 140 | | 175 | | 210 | Ω | 6.0 | 1000 | | |
| | | | 60 | 120 | | 150 | | 180 | Ω | 9.0 | 1000 | | |
| R_{ON} | ON resistance (rail) | | 170 | - | | - | | - | Ω | 2.0 | 100 | V_{CC} | V_{IH} or V_{IL} |
| | | | 90 | 180 | | 225 | | 270 | Ω | 4.5 | 1000 | | |
| | | | 80 | 160 | | 200 | | 240 | Ω | 6.0 | 1000 | | |
| | | | 65 | 135 | | 170 | | 205 | Ω | 9.0 | 1000 | | |
| ΔR_{ON} | maximum Δ ON resistance between any two channels | | - | | | | | | Ω | 2.0 | | V_{CC} to GND | V_{IH} or V_{IL} |
| | | | 16 | | | | | | Ω | 4.5 | | | |
| | | | 12 | | | | | | Ω | 6.0 | | | |
| | | | 9 | | | | | | Ω | 9.0 | | | |

Notes to the DC Characteristics

- At supply voltages approaching 2.0 V the analog switch ON-resistance becomes extremely non-linear. Therefore it is recommended that these devices be used to transmit digital signals only, when using these supply voltages.
- For test circuit measuring R_{ON} see Fig.6.

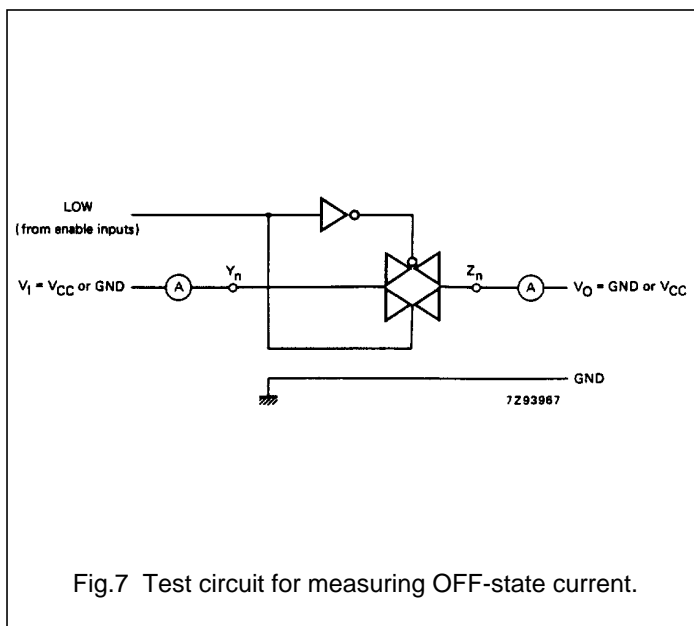
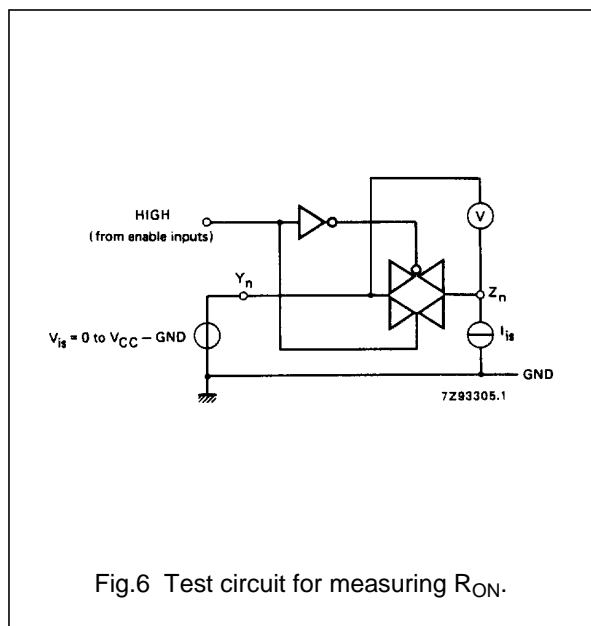

Quad bilateral switches

74HC/HCT4016

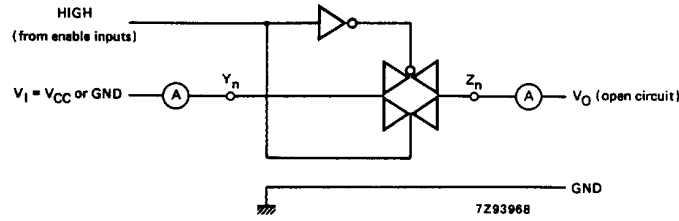

Fig.8 Test circuit for measuring ON-state current.

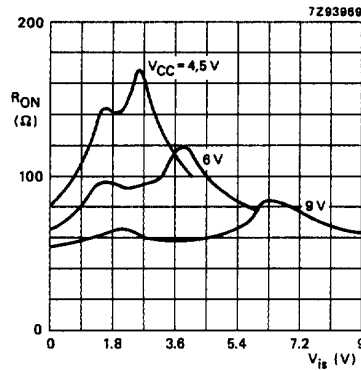

Fig.9 Typical R_{ON} as a function of input voltage V_{is} for $V_{is} = 0$ to V_{CC} .

Quad bilateral switches

74HC/HCT4016

DC CHARACTERISTICS FOR 74HC

Voltages are referenced to GND (ground = 0 V)

| SYMBOL | PARAMETER | T _{amb} (°C) | | | | | | | | UNIT | TEST CONDITIONS | | |
|-----------------|---|---------------------------|--------------------------|------------------------------|---------------------------|------------------------------|---------------------------|------------------------------|----|--------------------------|--|---|-------|
| | | 74HC | | | | | | | | | V _{CC} (V) | V _I | OTHER |
| | | +25 | | | -40 to +85 | | -40 to +125 | | | | | | |
| | | min. | typ. | max. | min. | max. | min. | max. | | | | | |
| V _{IH} | HIGH level input voltage | 1.5 3.15 4.2 6.3 | 1.2 2.4 3.2 4.3 | | 1.5 3.15 4.2 6.3 | | 1.5 3.15 4.2 6.3 | | V | 2.0 4.5 6.0 9.0 | | | |
| V _{IL} | LOW level input voltage | | 0.8 2.1 2.8 4.3 | 0.50 1.35 1.80 2.70 | | 0.50 1.35 1.80 2.70 | | 0.50 1.35 1.80 2.70 | V | 2.0 4.5 6.0 9.0 | | | |
| ±I _I | input leakage current | | | 0.1 0.2 | | 1.0 2.0 | | 1.0 2.0 | µA | 6.0 10.0 | V _{CC} or GND | | |
| ±I _S | analog switch OFF-state current per channel | | | 0.1 | | 1.0 | | 1.0 | µA | 10.0 | V _{IH} or V _{IL} | V _S = V _{CC} - GND (see Fig.7) | |
| ±I _S | analog switch ON-state current | | | 0.1 | | 1.0 | | 1.0 | µA | 10.0 | V _{IH} or V _{IL} | V _S = V _{CC} - GND (see Fig.8) | |
| I _{CC} | quiescent supply current | | | 2.0 4.0 | | 20.0 40.0 | | 40.0 80.0 | µA | 6.0 10.0 | V _{CC} or GND | V _{IS} = GND or V _{CC} ; V _{OS} = V _{CC} or GND | |

AC CHARACTERISTICS FOR 74HCGND = 0 V; t_r = t_f = 6 ns; C_L = 50 pF

| SYMBOL | PARAMETER | T _{amb} (°C) | | | | | | | | UNIT | TEST CONDITIONS | |
|-------------------------------------|---|-----------------------|----------------------|-----------------------|------------|-----------------------|-------------|-----------------------|----|--------------------------|---|-------|
| | | 74HC | | | | | | | | | V _{CC} (V) | OTHER |
| | | +25 | | | -40 to +85 | | -40 to +125 | | | | | |
| | | min. | typ. | max. | min. | max. | min. | max. | | | | |
| t _{PHL} / t _{PLH} | propagation delay V _{IS} to V _{OS} | | 17 6 5 4 | 60 12 10 8 | | 75 15 13 10 | | 90 18 15 12 | ns | 2.0 4.5 6.0 9.0 | R _L = ∞; C _L = 50 pF (see Fig.16) | |
| t _{PZH} / t _{PZL} | turn "ON" time E _n to V _{OS} | | 52 19 15 11 | 190 38 32 28 | | 240 48 41 35 | | 235 57 48 42 | ns | 2.0 4.5 6.0 9.0 | R _L = 1 kΩ; C _L = 50 pF (see Figs 17 and 18) | |
| t _{PHZ} / t _{PLZ} | turn "OFF" time E _n to V _{OS} | | 47 17 14 13 | 145 29 25 22 | | 180 36 31 28 | | 220 44 38 33 | ns | 2.0 4.5 6.0 9.0 | R _L = 1 kΩ; C _L = 50 pF (see Figs 17 and 18) | |

Quad bilateral switches

74HC/HCT4016

DC CHARACTERISTICS FOR 74HCT

Voltages are referenced to GND (ground = 0 V)

| SYMBOL | PARAMETER | T _{amb} (°C) | | | | | | | UNIT | TEST CONDITIONS | | |
|------------------|---|-----------------------|------|------|------------|------|-------------|------|------|------------------------|------------------------------------|---|
| | | 74HCT | | | | | | | | V _{CC} (V) | V _I | OTHER |
| | | +25 | | | -40 to +85 | | -40 to +125 | | | | | |
| | | min. | typ. | max. | min. | max. | min. | max. | | | | |
| V _{IH} | HIGH level input voltage | 2.0 | 1.6 | | 2.0 | | 2.0 | | V | 4.5 to 5.5 | | |
| V _{IL} | LOW level input voltage | | 1.2 | 0.8 | | 0.8 | | 0.8 | V | 4.5 to 5.5 | | |
| ±I _I | input leakage current | | | 0.1 | | 1.0 | | 1.0 | µA | 5.5 | V _{CC} or GND | |
| ±I _S | analog switch OFF-state current per channel | | | 0.1 | | 1.0 | | 1.0 | µA | 5.5 | V _{IH} or V _{IL} | V _S = V _{CC} - GND (see Fig.7) |
| ±I _S | analog switch ON-state current | | | 0.1 | | 1.0 | | 1.0 | µA | 5.5 | V _{IH} or V _{IL} | V _S = V _{CC} - GND (see Fig.8) |
| I _{CC} | quiescent supply current | | | 2.0 | | 20.0 | | 40.0 | µA | 4.5 to 5.5 | V _{CC} or GND | V _{is} = GND or V _{CC} ; V _{os} = V _{CC} or GND |
| ΔI _{CC} | additional quiescent supply current per input pin for unit load coefficient is 1 (note 1) | | 100 | 360 | | 450 | | 490 | µA | 4.5 to 5.5 | V _{CC} -2.1V | other inputs at V _{CC} or GND |

Note

- The value of additional quiescent supply current (ΔI_{CC}) for a unit load of 1 is given here. To determine ΔI_{CC} per input, multiply this value by the unit load coefficient shown in the table below.

| INPUT | UNIT LOAD COEFFICIENT |
|----------------|-----------------------|
| E _N | 1.00 |

Quad bilateral switches

74HC/HCT4016

AC CHARACTERISTICS FOR 74HCTGND = 0 V; $t_r = t_f = 6$ ns; $C_L = 50$ pF

| SYMBOL | PARAMETER | T_{amb} (°C) | | | | | | | | UNIT | TEST CONDITIONS | |
|-------------------|---|----------------|------|------|------------|------|-------------|------|----|------|--|-------|
| | | 74HCT | | | | | | | | | V_{CC} (V) | OTHER |
| | | +25 | | | -40 to +85 | | -40 to +125 | | | | | |
| | | min. | typ. | max. | min. | max. | min. | max. | | | | |
| t_{PHL}/t_{PLH} | propagation delay V_{is} to V_{os} | | 6 | 12 | | 15 | | 18 | ns | 4.5 | $R_L = \infty$; $C_L = 50$ pF (see Fig.16) | |
| t_{PZH} | turn "ON" time E_n to V_{os} | | 19 | 35 | | 44 | | 53 | ns | 4.5 | $R_L = 1$ k Ω ; $C_L = 50$ pF (see Figs 17 and 18) | |
| t_{PZL} | turn "ON" time E_n to V_{os} | | 20 | 35 | | 44 | | 53 | ns | 4.5 | $R_L = 1$ k Ω ; $C_L = 50$ pF (see Figs 17 and 18) | |
| t_{PHZ}/t_{PLZ} | turn "OFF" time E_n to V_{os} | | 23 | 35 | | 44 | | 53 | ns | 4.5 | $R_L = 1$ k Ω ; $C_L = 50$ pF (see Figs 17 and 18) | |

ADDITIONAL AC CHARACTERISTICS FOR 74HC/HCT**Recommended conditions and typical values**GND = 0 V; $t_r = t_f = 6$ ns

| SYMBOL | PARAMETER | typ. | UNIT | V_{CC} (V) | $V_{is(p-p)}$ (V) | CONDITIONS |
|-------------|---|--------------|------------|-----------------|----------------------|---|
| | sine-wave distortion $f = 1$ kHz | 0.80 0.40 | % % | 4.5 9.0 | 4.0 8.0 | $R_L = 10$ k Ω ; $C_L = 50$ pF (see Fig.14) |
| | sine-wave distortion $f = 10$ kHz | 2.40 1.20 | % % | 4.5 9.0 | 4.0 8.0 | $R_L = 10$ k Ω ; $C_L = 50$ pF (see Fig.14) |
| | switch "OFF" signal feed-through | -50 -50 | dB dB | 4.5 9.0 | note 3 | $R_L = 600$ Ω ; $C_L = 50$ pF; $f = 1$ MHz (see Figs 10 and 15) |
| | crosstalk between any two switches | -60 -60 | dB dB | 4.5 9.0 | note 3 | $R_L = 600$ Ω ; $C_L = 50$ pF; $f = 1$ MHz (see Fig.12) |
| $V_{(p-p)}$ | crosstalk voltage between enable or address input to any switch (peak-to-peak value) | 110 220 | mV mV | 4.5 9.0 | | $R_L = 600$ Ω ; $C_L = 50$ pF; $f = 1$ MHz (E_n , square wave between V_{CC} and GND, $t_r = t_f = 6$ ns) (see Fig.13) |
| f_{max} | minimum frequency response (-3dB) | 150 160 | MHz MHz | 4.5 9.0 | note 4 | $R_L = 50$ Ω ; $C_L = 10$ pF (see Figs 11 and 14) |
| C_S | maximum switch capacitance | 5 | pF | | | |

Notes

- V_{is} is the input voltage at a Y_n or Z_n terminal, whichever is assigned as an input.
- V_{os} is the output voltage at a Y_n or Z_n terminal, whichever is assigned as an output.
- Adjust input voltage V_{is} to 0 dBm level (0 dBm = 1 mW into 600 Ω).
- Adjust input voltage V_{is} to 0 dBm level at V_{os} for 1 MHz (0 dBm = 1 mW into 50 Ω).

Quad bilateral switches

74HC/HCT4016

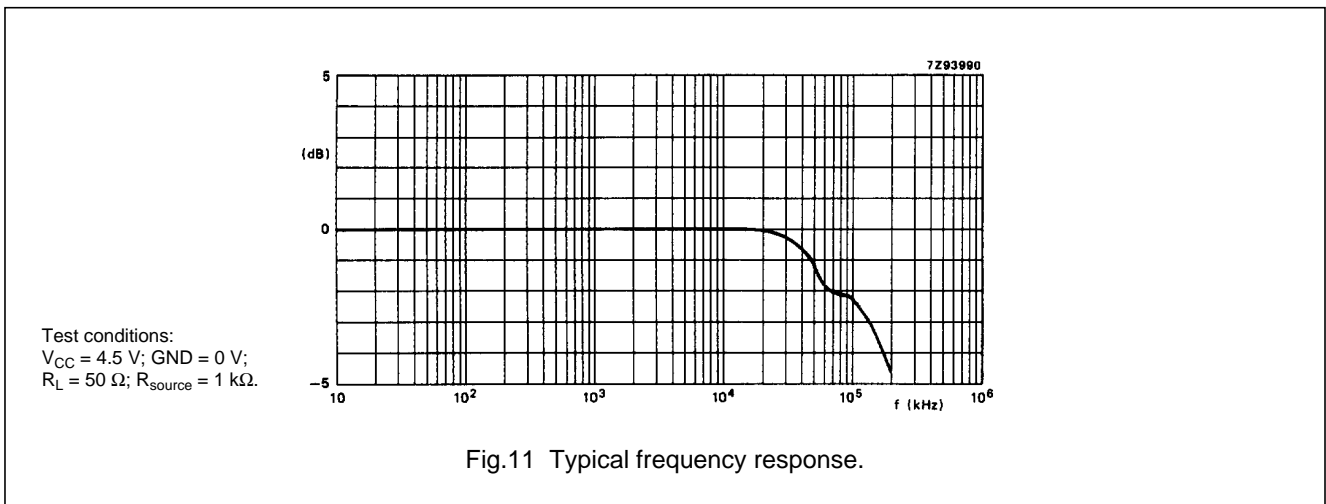
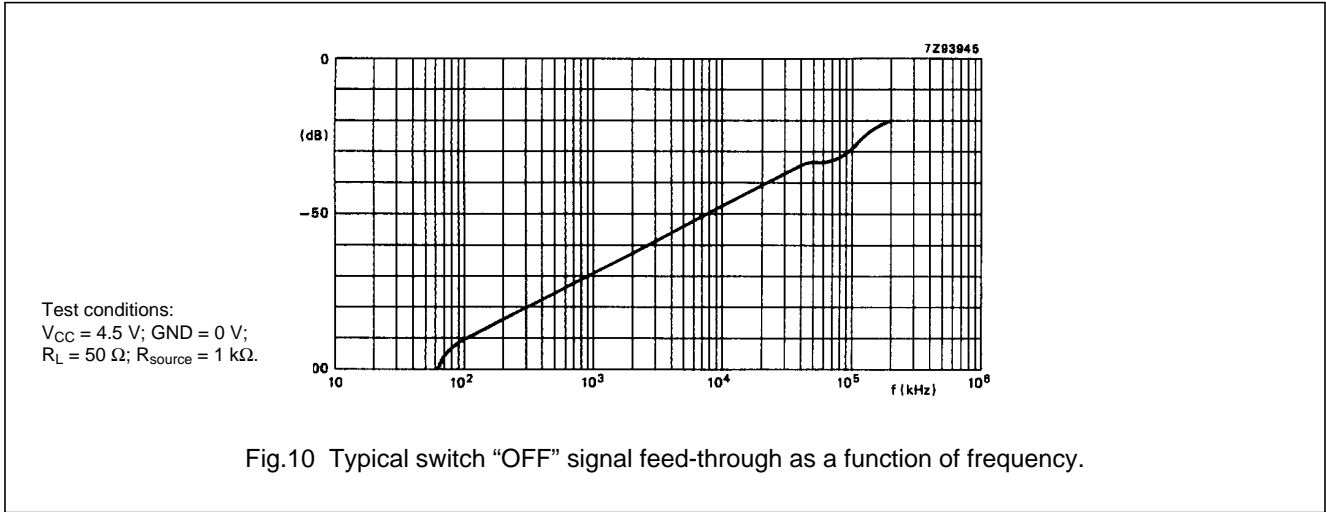

Quad bilateral switches

74HC/HCT4016

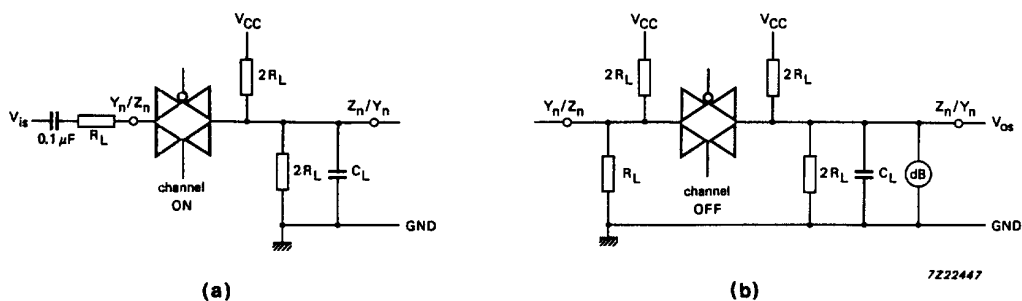

Fig. 12 Test circuit for measuring crosstalk between any two switches.
(a) channel ON condition; (b) channel OFF condition.

The crosstalk is defined as follows
(oscilloscope output):

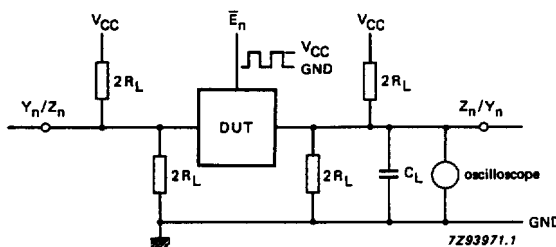
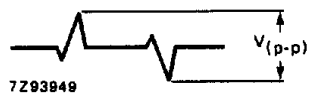

Fig. 13 Test circuit for measuring crosstalk between control and any switch.

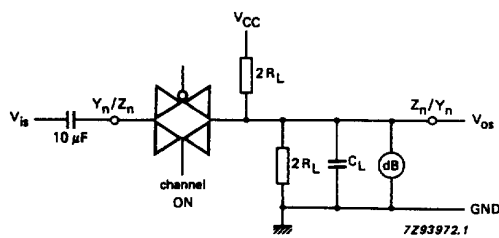

Fig. 14 Test circuit for measuring sine-wave distortion and minimum frequency response.

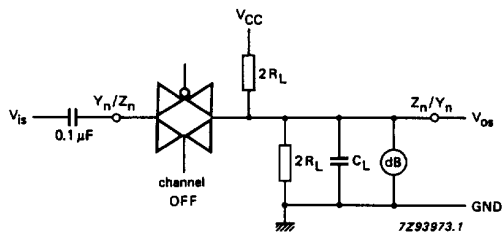

Fig. 15 Test circuit for measuring switch "OFF" signal feed-through.

Quad bilateral switches

74HC/HCT4016

AC WAVEFORMS

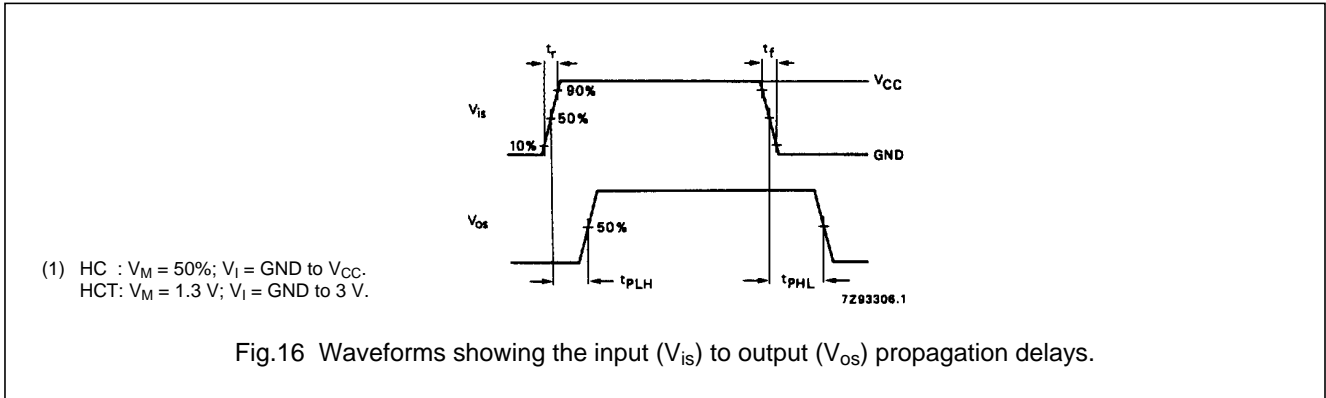

Fig.16 Waveforms showing the input (V_{is}) to output (V_{os}) propagation delays.

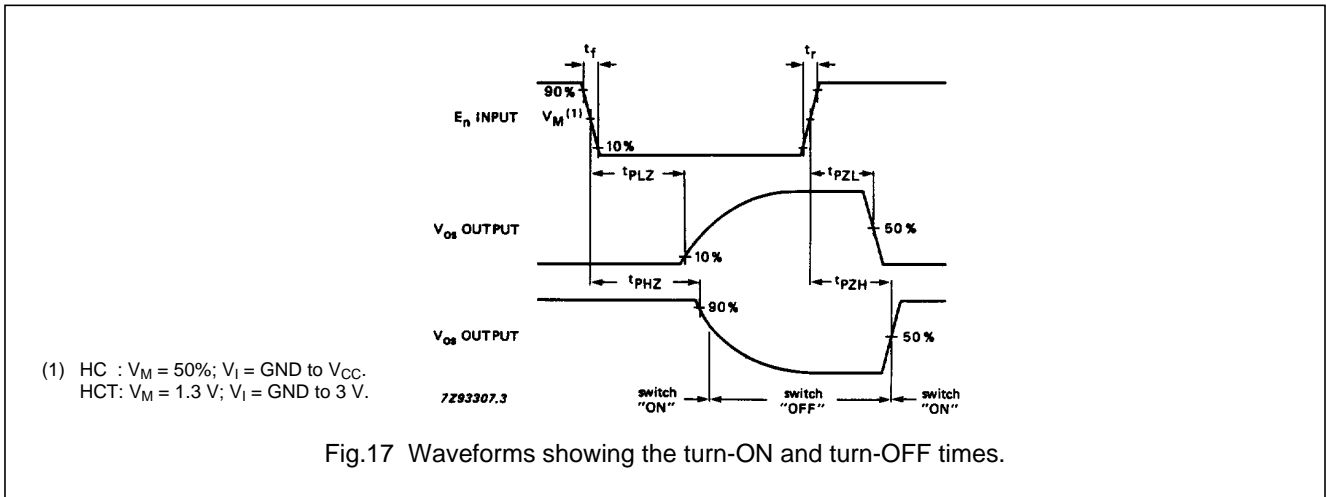

Fig.17 Waveforms showing the turn-ON and turn-OFF times.

Quad bilateral switches

74HC/HCT4016

TEST CIRCUIT AND WAVEFORMS

Conditions

| TEST | SWITCH | V _{is} |
|------------------|-----------------|-----------------|
| t _{PZH} | GND | V _{CC} |
| t _{PZL} | V _{CC} | GND |
| t _{PHZ} | GND | V _{CC} |
| t _{PLZ} | V _{CC} | GND |
| others | open | pulse |

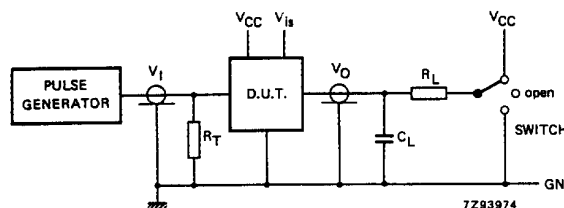

C_L = load capacitance including jig and probe capacitance (see AC CHARACTERISTICS for values).
 R_T = termination resistance should be equal to the output impedance Z_O of the pulse generator.
 t_r = t_f = 6 ns; when measuring f_{max}, there is no constraint t_r, t_f with 50% duty factor.

| FAMILY | AMPLITUDE | V _M | t _r ; t _f | |
|--------|-----------------|----------------|---------------------------------|-------|
| | | | f _{max} ; PULSE WIDTH | OTHER |
| 74HC | V _{CC} | 50% | < 2 ns | 6 ns |
| 74HCT | 3.0 V | 1.3 V | < 2 ns | 6 ns |

Fig.18 Test circuit for measuring AC performance.

C_L = load capacitance including jig and probe capacitance (see AC CHARACTERISTICS for values).
 R_T = termination resistance should be equal to the output impedance Z_O of the pulse generator.
 t_r = t_f = 6 ns; when measuring f_{max}, there is no constraint t_r, t_f with 50% duty factor.

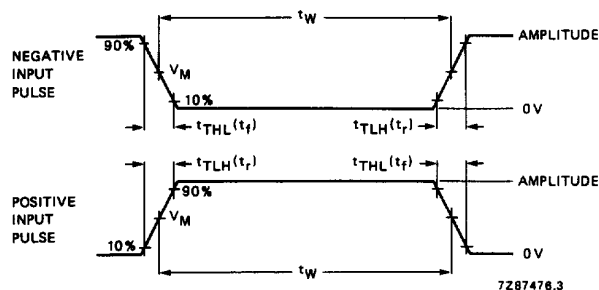

| FAMILY | AMPLITUDE | V _M | t _r ; t _f | |
|--------|-----------------|----------------|---------------------------------|-------|
| | | | f _{max} ; PULSE WIDTH | OTHER |
| 74HC | V _{CC} | 50% | < 2 ns | 6 ns |
| 74HCT | 3.0 V | 1.3 V | < 2 ns | 6 ns |

Fig.19 Input pulse definitions.

PACKAGE OUTLINES

See "74HC/HCT/HCU/HCMOS Logic Package Outlines".

Looking for pricing, stock, or lifecycle information?

Click below to explore more details on WIN SOURCE:

 [View 74HCT4016D,118 on WIN SOURCE](#)

 [NXP / Nexperia Information](#)

Optimize Your Supply Chain with WIN SOURCE Solutions

-  Global Sourcing Solution
-  Obsolete Management
-  Cost Control Management
-  Shortage Management
-  Alternative Solution
-  Excess Inventory Management