

74HC299; 74HCT299

8-bit universal shift register; 3-state

Rev. 03 — 28 July 2008

Product data sheet

1. General description

The 74HC299; 74HCT299 are high-speed Si-gate CMOS devices which are pin-compatible with Low-power Schottky TTL (LSTTL) devices. They are specified in compliance with JEDEC standard no. 7A.

The 74HC299; 74HCT299 contain eight edge-triggered D-type flip-flops and the interstage logic necessary to perform synchronous shift-right, shift-left, parallel load and hold operations. An operation is determined by the mode select inputs S0 and S1, as shown in [Table 3](#).

Pins I/O0 to I/O7 are flip-flop 3-state buffer outputs which allow them to operate as data inputs in parallel load mode. The serial outputs Q0 and Q7 are used for expansion in serial shifting of longer words.

A LOW signal on the asynchronous master reset input \overline{MR} overrides the Sn and clock CP inputs and resets the flip-flops. All other state changes are initiated by the rising edge of the clock pulse. Inputs can change when the clock is in either state, provided that the recommended set-up and hold times are observed.

A HIGH signal on the 3-state output enable inputs $\overline{OE}1$ or $\overline{OE}2$ disables the 3-state buffers and the I/O outputs are set to the high-impedance OFF-state. In this condition, the shift, hold, load and reset operations still occur when preparing for a parallel load operation. The 3-state buffers are also disabled by HIGH signals on both S0 and S1.

2. Features

- Multiplexed inputs/outputs provide improved bit density
- Four operating modes:
 - ◆ Shift left
 - ◆ Shift right
 - ◆ Hold (store)
 - ◆ Load data
- Operates with output enable or at high-impedance OFF-state (Z)
- 3-state outputs drive bus lines directly
- Cascadable for n-bit word lengths
- ESD protection:
 - ◆ HBM JESD22-A114E exceeds 2000 V
 - ◆ MM JESD22-A115-A exceeds 200 V
- Specified from $-40\text{ }^{\circ}\text{C}$ to $+85\text{ }^{\circ}\text{C}$ and from $-40\text{ }^{\circ}\text{C}$ to $+125\text{ }^{\circ}\text{C}$

3. Ordering information

Table 1. Ordering information

Type number	Package			Version
	Temperature range	Name	Description	
74HC299				
74HC299D	-40 °C to +125 °C	SO20	plastic small outline package; 20 leads; body width 7.5 mm	SOT163-1
74HC299DB	-40 °C to +125 °C	SSOP20	plastic shrink small outline package; 20 leads; body width 5.3 mm	SOT339-1
74HC299N	-40 °C to +125 °C	DIP20	plastic dual in-line package; 20 leads (300 mil)	SOT146-1
74HC299PW	-40 °C to +125 °C	TSSOP20	plastic thin shrink small outline package; 20 leads; body width 4.4 mm	SOT360-1
74HCT299				
74HCT299D	-40 °C to +125 °C	SO20	plastic small outline package; 20 leads; body width 7.5 mm	SOT163-1
74HCT299DB	-40 °C to +125 °C	SSOP20	plastic shrink small outline package; 20 leads; body width 5.3 mm	SOT339-1
74HCT299N	-40 °C to +125 °C	DIP20	plastic dual in-line package; 20 leads (300 mil)	SOT146-1
74HCT299PW	-40 °C to +125 °C	TSSOP20	plastic thin shrink small outline package; 20 leads; body width 4.4 mm	SOT360-1

4. Functional diagram

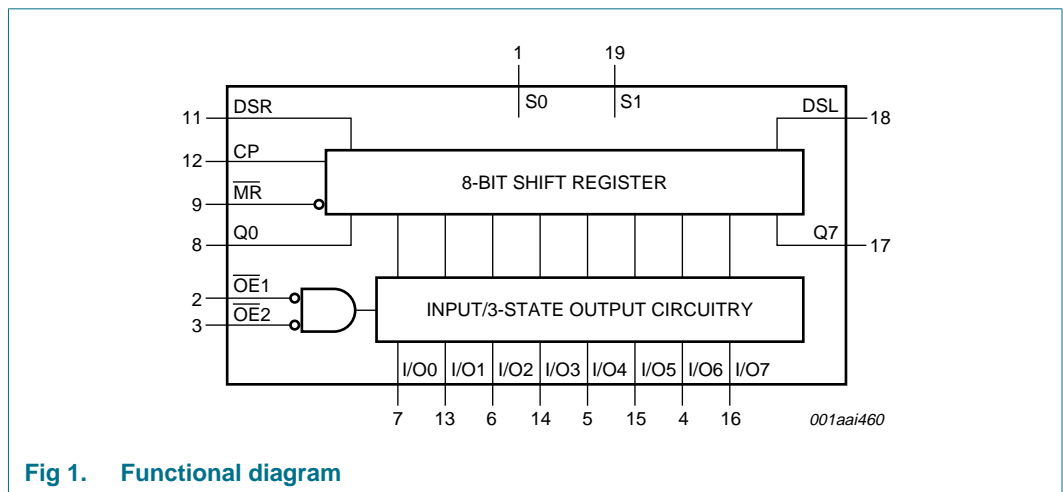

Fig 1. Functional diagram

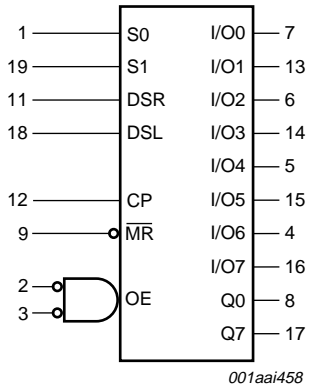

Fig 2. Logic symbol

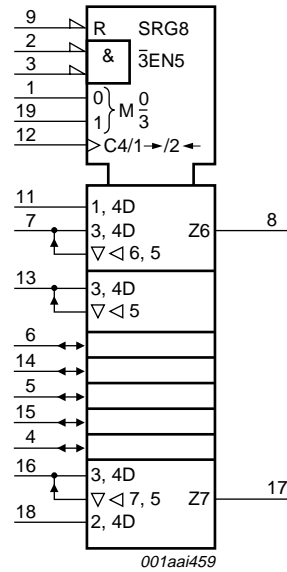

Fig 3. IEC logic symbol

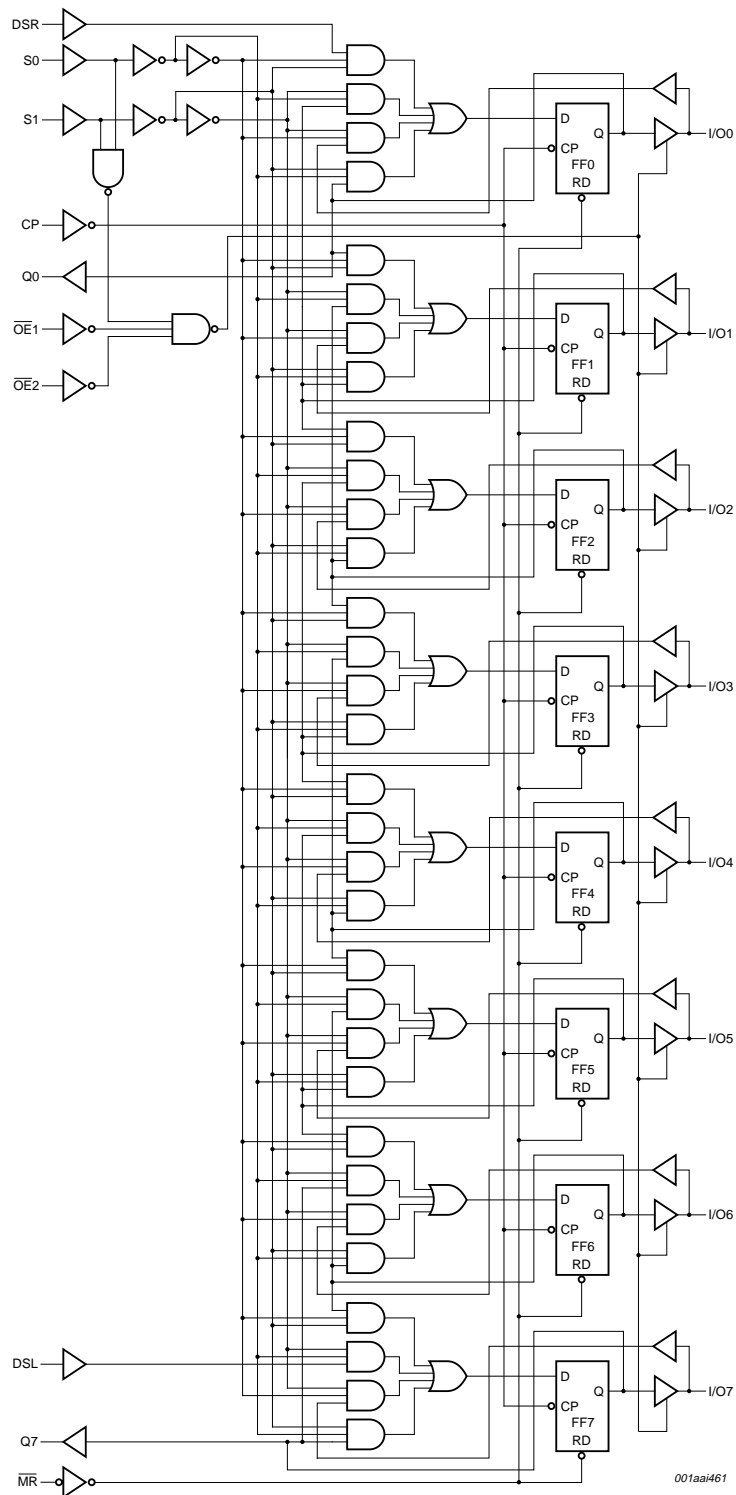

Fig 4. Logic diagram

5. Pinning information

5.1 Pinning

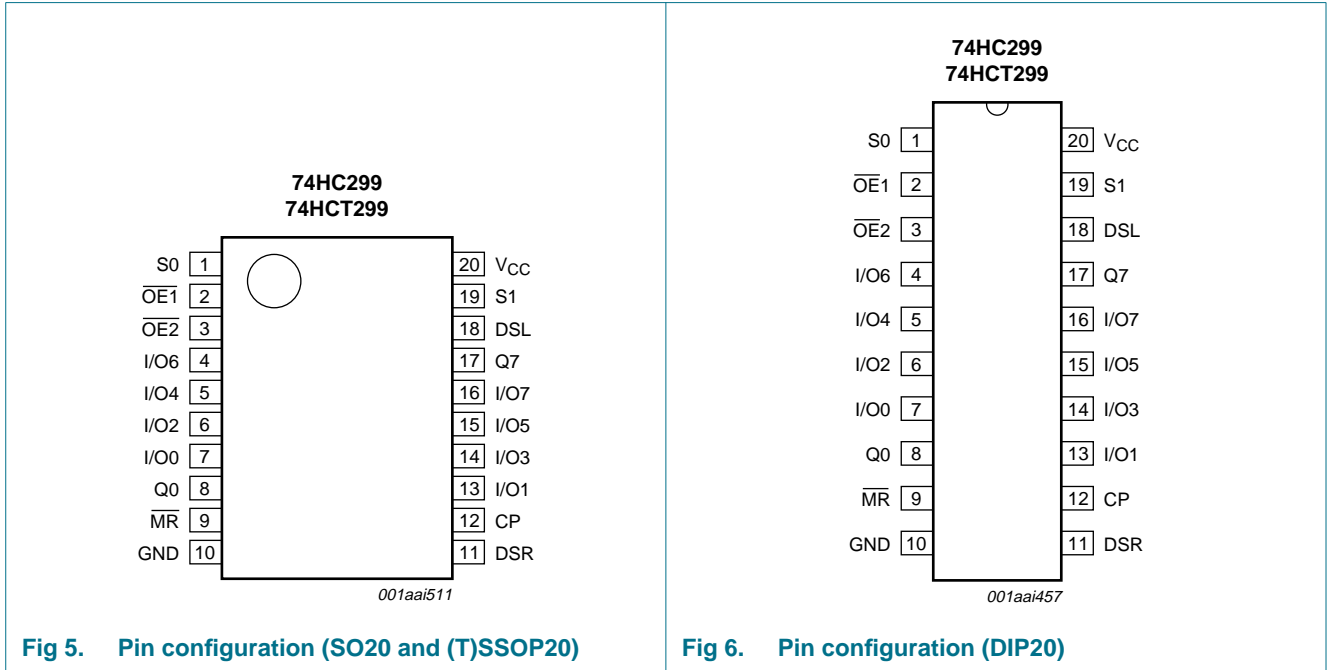

Fig 5. Pin configuration (SO20 and (T)SSOP20)

Fig 6. Pin configuration (DIP20)

5.2 Pin description

Table 2. Pin description

Symbol	Pin	Description
S0	1	mode select input
$\overline{OE1}$	2	3-state output enable input (active LOW)
$\overline{OE2}$	3	3-state output enable input (active LOW)
I/O6	4	parallel data input or 3-state parallel output (bus driver)
I/O4	5	parallel data input or 3-state parallel output (bus driver)
I/O2	6	parallel data input or 3-state parallel output (bus driver)
I/O0	7	parallel data input or 3-state parallel output (bus driver)
Q0	8	serial output (standard output)
\overline{MR}	9	asynchronous master reset input (active LOW)
GND	10	ground (0 V)
DSR	11	serial data shift-right input
CP	12	clock input (LOW to HIGH, edge-triggered)
I/O1	13	parallel data input or 3-state parallel output (bus driver)
I/O3	14	parallel data input or 3-state parallel output (bus driver)
I/O5	15	parallel data input or 3-state parallel output (bus driver)
I/O7	16	parallel data input or 3-state parallel output (bus driver)
Q7	17	serial output (standard output)

Table 2. Pin description ...continued

Symbol	Pin	Description
DSL	18	serial data shift-left input
S1	19	mode select input
V _{CC}	20	positive supply voltage

6. Functional description

Table 3. Function table^[1]

Input				Response
MR	S1	S0	CP	
L	X	X	X	asynchronous reset; Q0 to Q7 = LOW
H	H	H	↑	parallel load; I/On → Qn
H	L	H	↑	shift right; DSR → Q0, Q0 → Q1, etc.
H	H	L	↑	shift left; DSL → Q7, Q7 → Q6, etc.
H	L	L	X	hold

- [1] H = HIGH voltage level;
 L = LOW voltage level;
 ↑ = LOW to HIGH CP transition;
 X = don't care.

7. Limiting values

Table 4. Limiting values

In accordance with the Absolute Maximum Rating System (IEC 60134). Voltages are referenced to GND (ground = 0 V).

Symbol	Parameter	Conditions	Min	Max	Unit
V _{CC}	supply voltage		-0.5	+7	V
I _{IK}	input clamping current	V _I < -0.5 V or V _I > V _{CC} + 0.5 V	[1] -	±20	mA
I _{OK}	output clamping current	V _O < -0.5 V or V _O > V _{CC} + 0.5 V	[1] -	±20	mA
I _O	output current	-0.5 V < V _O < V _{CC} + 0.5 V			
	standard outputs		-	±25	mA
	bus driver outputs		-	±35	mA
I _{CC}	supply current				
	standard outputs		-	50	mA
	bus driver outputs		-	70	mA
I _{GND}	ground current				
	standard outputs		-50	-	mA
	bus driver outputs		-70	-	mA
T _{stg}	storage temperature		-65	+150	°C
P _{tot}	total power dissipation	T _{amb} = -40 °C to +125 °C			
		DIP20 package	[2] -	750	mW
		SO20 package	[3] -	500	mW
		(T)SSOP20 package	[4] -	500	mW

[1] The input and output voltage ratings may be exceeded if the input and output current ratings are observed.

- [2] P_{tot} derates linearly at 12 mW/K above 70 °C.
- [3] P_{tot} derates linearly at 8 mW/K above 70 °C.
- [4] P_{tot} derates linearly at 5.5 mW/K above 60 °C.

8. Recommended operating conditions

Table 5. Recommended operating conditions

Voltages are referenced to GND (ground = 0 V).

Symbol	Parameter	Conditions	74HC299			74HCT299			Unit
			Min	Typ	Max	Min	Typ	Max	
V_{CC}	supply voltage		2.0	5.0	6.0	4.5	5.0	5.5	V
V_I	input voltage		0	-	V_{CC}	0	-	V_{CC}	V
V_O	output voltage		0	-	V_{CC}	0	-	V_{CC}	V
T_{amb}	ambient temperature		-40	-	+125	-40	-	+125	°C
$\Delta t/\Delta V$	input transition rise and fall rate								
		$V_{CC} = 2.0\text{ V}$	-	-	625	-	-	-	ns/V
		$V_{CC} = 4.5\text{ V}$	-	1.67	139	-	1.67	1.39	ns/V
		$V_{CC} = 6.0\text{ V}$	-	-	83	-	-	-	ns/V

9. Static characteristics

Table 6. Static characteristics

At recommended operating conditions; voltages are referenced to GND (ground = 0 V).

Symbol	Parameter	Conditions	25 °C			-40 °C to +85 °C		-40 °C to +125 °C		Unit
			Min	Typ	Max	Min	Max	Min	Max	
74HC299										
V_{IH}	HIGH-level input voltage	$V_{CC} = 2.0\text{ V}$	1.5	1.2	-	1.5	-	1.5	-	V
		$V_{CC} = 4.5\text{ V}$	3.15	2.4	-	3.15	-	3.15	-	V
		$V_{CC} = 6.0\text{ V}$	4.2	3.2	-	4.2	-	4.2	-	V
V_{IL}	LOW-level input voltage	$V_{CC} = 2.0\text{ V}$	-	0.8	0.5	-	0.5	-	0.5	V
		$V_{CC} = 4.5\text{ V}$	-	2.1	1.35	-	1.35	-	1.35	V
		$V_{CC} = 6.0\text{ V}$	-	2.8	1.8	-	1.8	-	1.8	V

Table 6. Static characteristics ...continued

At recommended operating conditions; voltages are referenced to GND (ground = 0 V).

Symbol	Parameter	Conditions	25 °C			-40 °C to +85 °C		-40 °C to +125 °C		Unit
			Min	Typ	Max	Min	Max	Min	Max	
V _{OH}	HIGH-level output voltage	V _I = V _{IH} or V _{IL}								
		all outputs								
		I _O = -20 μA; V _{CC} = 2.0 V	1.9	2.0	-	1.9	-	1.9	-	V
		I _O = -20 μA; V _{CC} = 4.5 V	4.4	4.5	-	4.4	-	4.4	-	V
		I _O = -20 μA; V _{CC} = 6.0 V	5.9	6.0	-	5.9	-	5.9	-	V
		standard outputs								
		I _O = -4.0 mA; V _{CC} = 4.5 V	3.98	4.32	-	3.84	-	3.7	-	V
		I _O = -5.2 mA; V _{CC} = 6.0 V	5.48	5.81	-	5.34	-	5.2	-	V
		bus driver outputs								
		I _O = -6.0 mA; V _{CC} = 4.5 V	3.98	4.32	-	3.84	-	3.7	-	V
I _O = -7.8 mA; V _{CC} = 6.0 V	5.48	5.81	-	5.34	-	5.2	-	V		
V _{OL}	LOW-level output voltage	V _I = V _{IH} or V _{IL}								
		all outputs								
		I _O = 20 μA; V _{CC} = 2.0 V	-	0	0.1	-	0.1	-	0.1	V
		I _O = 20 μA; V _{CC} = 4.5 V	-	0	0.1	-	0.1	-	0.1	V
		I _O = 20 μA; V _{CC} = 6.0 V	-	0	0.1	-	0.1	-	0.1	V
		standard outputs								
		I _O = 4.0 mA; V _{CC} = 4.5 V	-	0.15	0.26	-	0.33	-	0.4	V
		I _O = 5.2 mA; V _{CC} = 6.0 V	-	0.16	0.26	-	0.33	-	0.4	V
		bus driver outputs								
		I _O = 6.0 mA; V _{CC} = 4.5 V	-	0.15	0.26	-	0.33	-	0.4	V
I _O = 7.8 mA; V _{CC} = 6.0 V	-	0.16	0.26	-	0.33	-	0.4	V		
I _I	input leakage current	V _I = V _{CC} or GND; V _{CC} = 6.0 V	-	-	±0.1	-	±1.0	-	±1.0	μA
I _{OZ}	OFF-state output current	V _I = V _{IH} or V _{IL} ; V _O = V _{CC} or GND; V _{CC} = 6.0 V	-	-	±0.5	-	±5.0	-	±10.0	μA
I _{CC}	supply current	V _I = V _{CC} or GND; I _O = 0 A; V _{CC} = 6.0 V	-	-	8.0	-	80	-	160	μA
C _I	input capacitance		-	3.5	-	-	-	-	-	pF
C _{I/O}	input/output capacitance		-	10	-	-	-	-	-	pF
C _{PD}	power dissipation capacitance	per package	[1]	-	120	-	-	-	-	pF
74HCT299										
V _{IH}	HIGH-level input voltage	V _{CC} = 4.5 V to 5.5 V	2.0	1.6	-	2.0	-	2.0	-	V

Table 6. Static characteristics ...continued

At recommended operating conditions; voltages are referenced to GND (ground = 0 V).

Symbol	Parameter	Conditions	25 °C			-40 °C to +85 °C		-40 °C to +125 °C		Unit		
			Min	Typ	Max	Min	Max	Min	Max			
V _{IL}	LOW-level input voltage	V _{CC} = 4.5 V to 5.5 V	-	1.2	0.8	-	0.8	-	0.8	V		
V _{OH}	HIGH-level output voltage	V _I = V _{IH} or V _{IL} ; V _{CC} = 4.5 V										
		all outputs										
		I _O = -20 μA	4.4	4.5	-	4.4	-	4.4	-	V		
		standard outputs										
V _{OL}	LOW-level output voltage	V _I = V _{IH} or V _{IL} ; V _{CC} = 4.5 V										
		all outputs										
		I _O = 20 μA	-	0	0.1	-	0.1	-	0.1	V		
		standard outputs										
I _I	input leakage current	V _I = V _{CC} or GND; V _{CC} = 5.5 V	-	-	±0.1	-	±1.0	-	±1.0	μA		
		I _{OZ}	OFF-state output current	V _I = V _{IH} or V _{IL} ; V _O = V _{CC} or GND per input pin; other inputs at V _{CC} or GND; I _O = 0 A; V _{CC} = 5.5 V	-	-	±0.5	-	±5.0	-	±10.0	μA
		I _{CC}	supply current	V _I = V _{CC} or GND; I _O = 0 A; V _{CC} = 5.5 V	-	-	8.0	-	80	-	160	μA
		ΔI _{CC}	additional supply current	per input pin; V _I = V _{CC} - 2.1 V; other inputs at V _{CC} or GND; I _O = 0 A; V _{CC} = 4.5 V to 5.5 V								
C _I	input capacitance	I/On, DSR, DSL, MR and S1	-	25	90	-	112.5	-	122.5	μA		
		CP, S0	-	60	216	-	270	-	294	μA		
		OE _n	-	30	108	-	135	-	147	μA		
C _{I/O}	input/output capacitance		-	3.5	-	-	-	-	pF			
C _{PD}	power dissipation capacitance	per package	[1]	-	125	-	-	-	-	pF		

[1] C_{PD} is used to determine the dynamic power dissipation (P_D in μW).

$$P_D = C_{PD} \times V_{CC}^2 \times f_i + \sum(C_L \times V_{CC}^2 \times f_o) \text{ where:}$$

f_i = input frequency in MHz;

f_o = output frequency in MHz;

$\Sigma(C_L \times V_{CC}^2 \times f_o)$ = sum of outputs.
 C_L = output load capacitance in pF;
 V_{CC} = supply voltage in V;
 V_I = GND to V_{CC} for 74HC299;
 V_I = GND to ($V_{CC} - 1.5$ V) for 74HCT299.

10. Dynamic characteristics

Table 7. Dynamic characteristics
 GND (ground = 0 V); for test circuit, see [Figure 11](#).

Symbol	Parameter	Conditions	25 °C			-40 °C to +85 °C		-40 °C to +125 °C		Unit
			Min	Typ	Max	Min	Max	Min	Max	
74HC299										
t_{pd}	propagation delay	CP to Q0, Q7; see Figure 7 ^[1]								
		$V_{CC} = 2.0$ V	-	66	200	-	250	-	300	ns
		$V_{CC} = 4.5$ V	-	24	40	-	50	-	60	ns
		$V_{CC} = 5.0$ V; $C_L = 15$ pF	-	20	-	-	-	-	-	ns
		$V_{CC} = 6.0$ V	-	19	34	-	43	-	51	ns
		CP to I/On; see Figure 7								
		$V_{CC} = 2.0$ V	-	66	200	-	250	-	300	ns
		$V_{CC} = 4.5$ V	-	24	40	-	50	-	60	ns
		$V_{CC} = 5.0$ V; $C_L = 15$ pF	-	20	-	-	-	-	-	ns
		$V_{CC} = 6.0$ V	-	19	34	-	43	-	51	ns
		\overline{MR} to Q0, Q7 or I/On; see Figure 8 ^[2]								
		$V_{CC} = 2.0$ V	-	66	200	-	250	-	300	ns
		$V_{CC} = 4.5$ V	-	24	40	-	50	-	60	ns
		$V_{CC} = 5.0$ V; $C_L = 15$ pF	-	20	-	-	-	-	-	ns
		$V_{CC} = 6.0$ V	-	19	34	-	43	-	51	ns
		t_t	transition time	bus driver (I/On); see Figure 7 ^[3]						
$V_{CC} = 2.0$ V	-			14	60	-	75	-	90	ns
$V_{CC} = 4.5$ V	-			5	12	-	15	-	18	ns
$V_{CC} = 6.0$ V	-			4	10	-	13	-	15	ns
standard (Q0, Q7); see Figure 7										
$V_{CC} = 2.0$ V	-			19	75	-	95	-	110	ns
$V_{CC} = 4.5$ V	-			7	15	-	19	-	22	ns
$V_{CC} = 6.0$ V	-			6	13	-	16	-	19	ns

Table 7. Dynamic characteristics ...continued
 GND (ground = 0 V); for test circuit, see [Figure 11](#).

Symbol	Parameter	Conditions	25 °C			-40 °C to +85 °C		-40 °C to +125 °C		Unit
			Min	Typ	Max	Min	Max	Min	Max	
t _w	pulse width	CP HIGH or LOW; see Figure 7								
		V _{CC} = 2.0 V	80	17	-	100	-	120	-	ns
		V _{CC} = 4.5 V	16	6	-	20	-	24	-	ns
		V _{CC} = 6.0 V	14	5	-	17	-	20	-	ns
		$\overline{\text{MR}}$ LOW; see Figure 8								
		V _{CC} = 2.0 V	80	19	-	100	-	120	-	ns
t _{PZH}	OFF-state to HIGH propagation delay	$\overline{\text{OEn}}$ to I/On; see Figure 10 ^[4]								
		V _{CC} = 2.0 V	-	50	155	-	195	-	235	ns
		V _{CC} = 4.5 V	-	18	31	-	39	-	47	ns
t _{PZL}	OFF-state to LOW propagation delay	$\overline{\text{OEn}}$ to I/On; see Figure 10								
		V _{CC} = 2.0 V	-	41	130	-	165	-	195	ns
		V _{CC} = 4.5 V	-	15	26	-	33	-	39	ns
t _{PHZ}	HIGH to OFF-state propagation delay	$\overline{\text{OEn}}$ to I/On; see Figure 10 ^[5]								
		V _{CC} = 2.0 V	-	66	185	-	230	-	280	ns
		V _{CC} = 4.5 V	-	24	37	-	46	-	56	ns
t _{PLZ}	LOW to OFF-state propagation delay	$\overline{\text{OEn}}$ to I/On; see Figure 10								
		V _{CC} = 2.0 V	-	55	155	-	195	-	235	ns
		V _{CC} = 4.5 V	-	20	31	-	39	-	47	ns
t _{rec}	recovery time	$\overline{\text{MR}}$ to CP; see Figure 8								
		V _{CC} = 2.0 V	5	-14	-	5	-	5	-	ns
		V _{CC} = 4.5 V	5	-5	-	5	-	5	-	ns
		V _{CC} = 6.0 V	5	-4	-	5	-	5	-	ns

Table 7. Dynamic characteristics ...continued
 GND (ground = 0 V); for test circuit, see [Figure 11](#).

Symbol	Parameter	Conditions	25 °C			-40 °C to +85 °C		-40 °C to +125 °C		Unit
			Min	Typ	Max	Min	Max	Min	Max	
t _{su}	set-up time	DSR, DSL to CP; see Figure 7								
		V _{CC} = 2.0 V	100	33	-	125	-	150	-	ns
		V _{CC} = 4.5 V	20	12	-	25	-	30	-	ns
		V _{CC} = 6.0 V	17	10	-	21	-	26	-	ns
		S0, S1 to CP; see Figure 9								
		V _{CC} = 2.0 V	100	33	-	125	-	150	-	ns
		V _{CC} = 4.5 V	20	12	-	25	-	30	-	ns
		V _{CC} = 6.0 V	17	10	-	21	-	26	-	ns
		I/On to CP; see Figure 7								
		V _{CC} = 2.0 V	125	39	-	155	-	190	-	ns
		V _{CC} = 4.5 V	25	14	-	31	-	38	-	ns
		V _{CC} = 6.0 V	21	11	-	26	-	32	-	ns
t _h	hold time	I/On, DSR, DSL to CP; see Figure 7								
		V _{CC} = 2.0 V	0	-14	-	0	-	0	-	ns
		V _{CC} = 4.5 V	0	-5	-	0	-	0	-	ns
		V _{CC} = 6.0 V	0	-4	-	0	-	0	-	ns
		S0, S1 to CP; see Figure 9								
		V _{CC} = 2.0 V	0	-28	-	0	-	0	-	ns
		V _{CC} = 4.5 V	0	-10	-	0	-	0	-	ns
		V _{CC} = 6.0 V	0	-8	-	0	-	0	-	ns
		f _{max}	maximum frequency	CP input; see Figure 7						
V _{CC} = 2.0 V	5.0			15	-	4.0	-	3.4	-	MHz
V _{CC} = 4.5 V	25			45	-	20	-	17	-	MHz
V _{CC} = 5.0 V; C _L = 15 pF	-			50	-	-	-	-	-	MHz
V _{CC} = 6.0 V	29			54	-	24	-	20	-	MHz

74HCT299

t _{pd}	propagation delay	CP to Q0, Q7; see Figure 7								
		V _{CC} = 4.5 V	-	22	37	-	46	-	56	ns
		V _{CC} = 5.0 V; C _L = 15 pF	-	19	-	-	-	-	-	ns
		CP to I/On; see Figure 7								
		V _{CC} = 4.5 V	-	22	37	-	46	-	56	ns
		V _{CC} = 5.0 V; C _L = 15 pF	-	19	-	-	-	-	-	ns
		M \bar{R} to Q0, Q7 or I/On; see Figure 8								
		V _{CC} = 4.5 V	-	27	46	-	58	-	69	ns
V _{CC} = 5.0 V; C _L = 15 pF	-	23	-	-	-	-	-	ns		

Table 7. Dynamic characteristics ...continued
 GND (ground = 0 V); for test circuit, see [Figure 11](#).

Symbol	Parameter	Conditions	25 °C			-40 °C to +85 °C		-40 °C to +125 °C		Unit
			Min	Typ	Max	Min	Max	Min	Max	
t _t	transition time	bus driver (I/On); see Figure 7 [3]								
		V _{CC} = 4.5 V	-	5	12	-	15	-	18	ns
		standard (Q0, Q7); see Figure 7								
t _W	pulse width	clock HIGH or LOW; see Figure 7								
		V _{CC} = 4.5 V	20	10	-	25	-	30	-	ns
		master reset LOW; see Figure 8								
t _{en}	enable time	\overline{OEn} to I/On; see Figure 10 [4]								
		V _{CC} = 4.5 V	-	19	30	-	38	-	45	ns
t _{PHZ}	HIGH to OFF-state propagation delay	\overline{OEn} to I/On; see Figure 10 [5]								
		V _{CC} = 4.5 V	-	24	37	-	46	-	56	ns
t _{PLZ}	LOW to OFF-state propagation delay	\overline{OEn} to I/On; see Figure 10								
		V _{CC} = 4.5 V	-	20	32	-	40	-	48	ns
t _{rec}	recovery time	\overline{MR} to CP; see Figure 8								
		V _{CC} = 4.5 V	10	2	-	9	-	11	-	ns
t _{su}	set-up time	I/On, DSR, DSL to CP; see Figure 7								
		V _{CC} = 4.5 V	25	14	-	31	-	38	-	ns
		S0, S1 to CP; see Figure 9								
		V _{CC} = 4.5 V	32	18	-	40	-	48	-	ns
t _h	hold time	I/On, DSR, DSL to CP; see Figure 7								
		V _{CC} = 4.5 V	0	-11	-	0	-	0	-	ns
		S0, S1 to CP; see Figure 9								
		V _{CC} = 4.5 V	0	-17	-	0	-	0	-	ns
f _{max}	maximum frequency	CP input; see Figure 7								
		V _{CC} = 4.5 V	25	42	-	20	-	17	-	MHz
		V _{CC} = 5.0 V; C _L = 15 pF	-	46	-	-	-	-	-	MHz

- [1] t_{pd} is the same as t_{PHL} and t_{PLH}.
- [2] t_{pd} is the same as t_{PHL}.
- [3] t_t is the same as t_{THL} and t_{TLH}.
- [4] t_{en} is the same as t_{PZH} and t_{PZL}.
- [5] t_{dis} is the same as t_{PHZ} and t_{PLZ}.

- [6] C_{PD} is used to determine the dynamic power dissipation (P_D in μW).
- $P_D = C_{PD} \times V_{CC}^2 \times f_i \times N + \Sigma(C_L \times V_{CC}^2 \times f_o)$ where:
- f_i = input frequency in MHz;
 - f_o = output frequency in MHz;
 - $\Sigma(C_L \times V_{CC}^2 \times f_o)$ = sum of outputs;
 - C_L = output load capacitance in pF;
 - V_{CC} = supply voltage in V;
 - N = number of inputs switching.

11. Waveforms

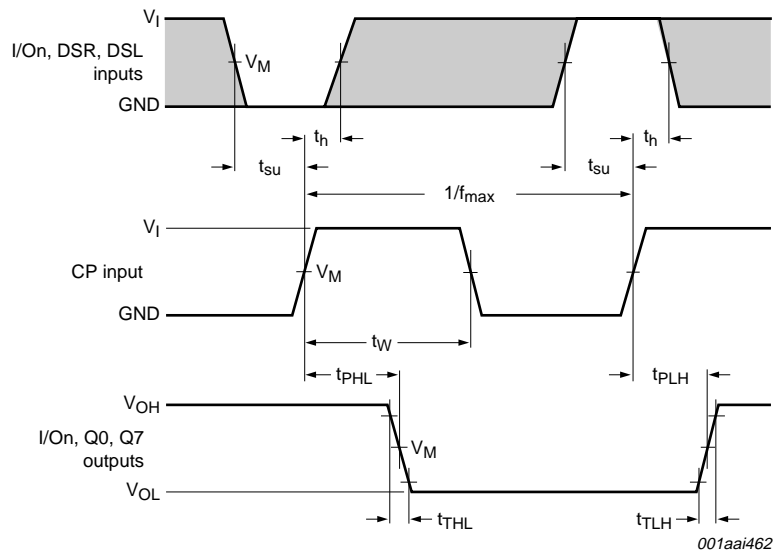

The shaded areas indicate when the input is permitted to change for predictable output performance. Measurement points are given in [Table 8](#). V_{OL} and V_{OH} are typical voltage output levels that occur with the output load.

Fig 7. Clock pulse to outputs I/On, Q0, Q7 propagation delays, the clock pulse width, the I/On, DSR and DSL to clock pulse set-up and hold times, the output transition times and the maximum clock frequency

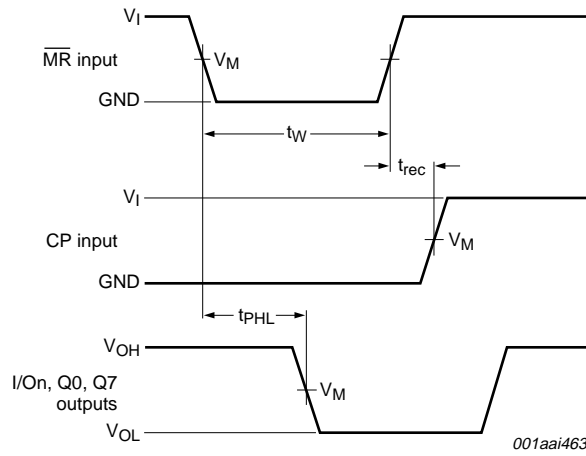

Measurement points are given in [Table 8](#).

V_{OL} and V_{OH} are typical voltage output levels that occur with the output load.

Fig 8. The master reset pulse width (LOW), the master reset to outputs I/On, Q0, Q7 propagation delays and the master reset to clock pulse removal time

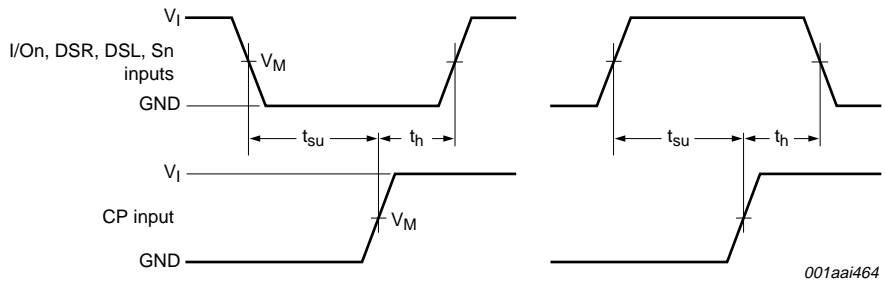

Measurement points are given in [Table 8](#).

Fig 9. Set-up and hold times from the mode control inputs S0, S1 to the clock pulse

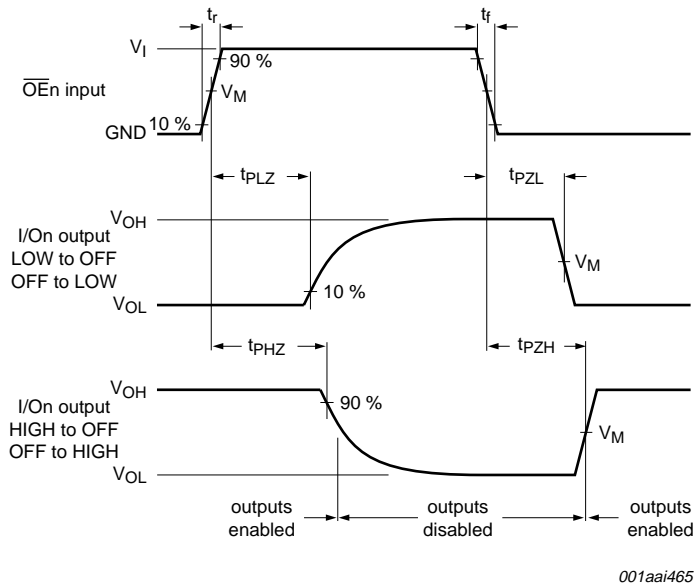

Measurement points are given in [Table 8](#).
 V_{OL} and V_{OH} are typical voltage output levels that occur with the output load.

Fig 10. 3-state enable and disable times for \overline{OEn} inputs

Table 8. Measurement points

Type	Input		Output
	V_I	V_M	V_M
74HC299	V_{CC}	$0.5V_{CC}$	$0.5V_{CC}$
74HCT299	3 V	1.3 V	1.3 V

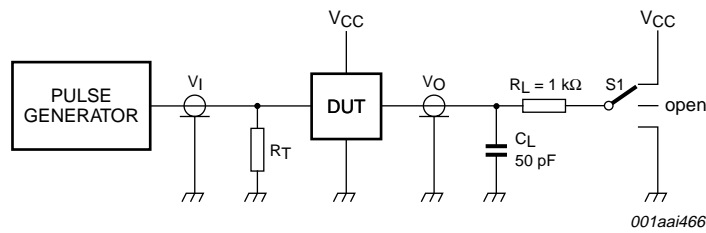

Test data is given in [Table 9](#).
 Definitions for test circuit:
 DUT = Device Under Test.
 R_T = Termination resistance should be equal to output impedance Z_o of the pulse generator.
 C_L = Load capacitance including jig and probe capacitance.
 R_L = Load resistance.
 S1 = Test selection switch

Fig 11. Test circuit for measuring switching times

Table 9. Test data

Type	Input		Load		S1 position
	V _I	t _r , t _f	C _L	R _L	t _{PHL} , t _{PLH}
74HC299	V _{CC}	6 ns	15 pF, 50 pF	1 kΩ	open
74HCT299	3 V	6 ns	15 pF, 50 pF	1 kΩ	open

12. Package outline

SO20: plastic small outline package; 20 leads; body width 7.5 mm

SOT163-1

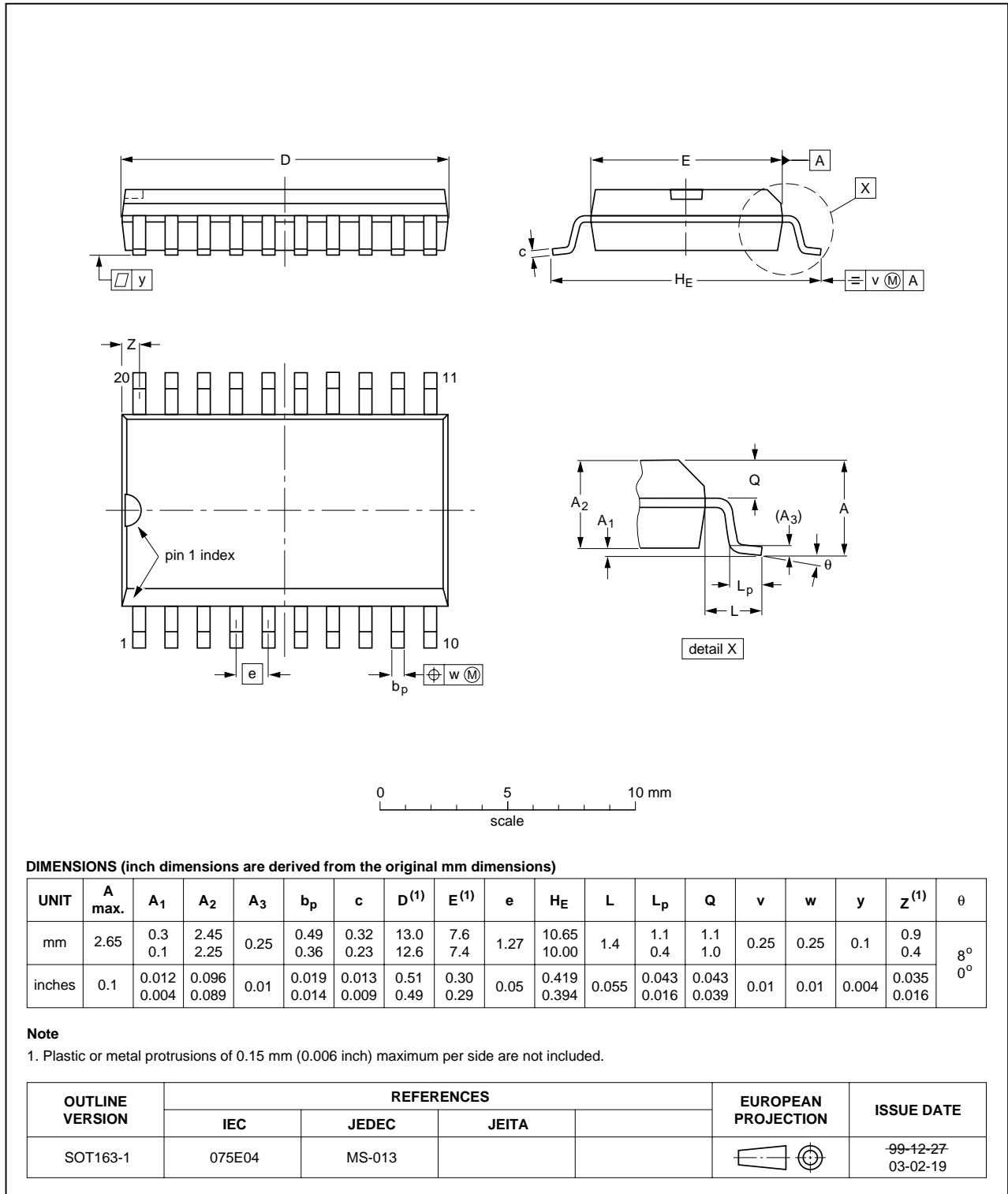

Fig 12. Package outline SOT163-1 (SO20)

SSOP20: plastic shrink small outline package; 20 leads; body width 5.3 mm

SOT339-1

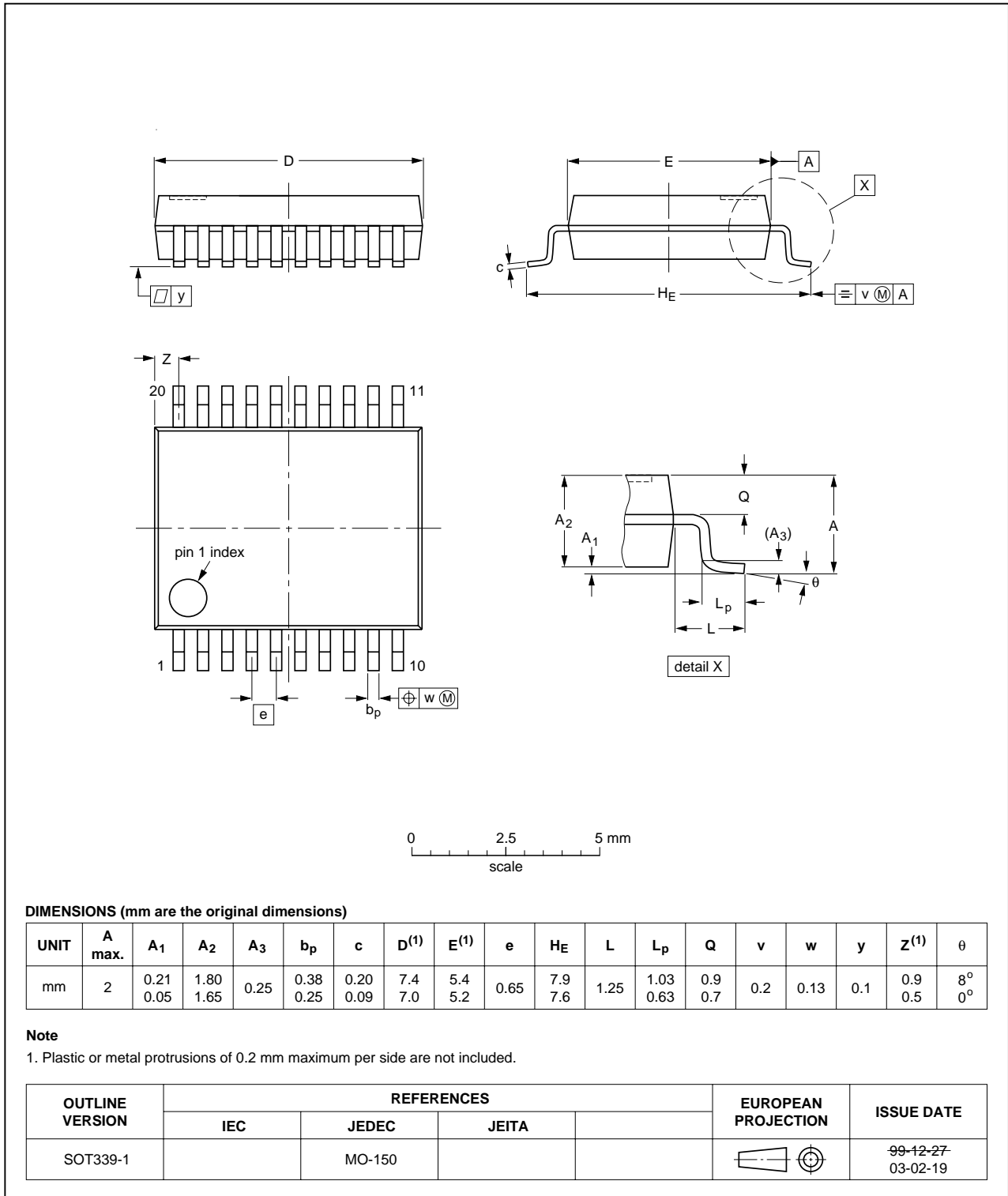

Fig 13. Package outline SOT339-1 (SSOP20)

DIP20: plastic dual in-line package; 20 leads (300 mil)

SOT146-1

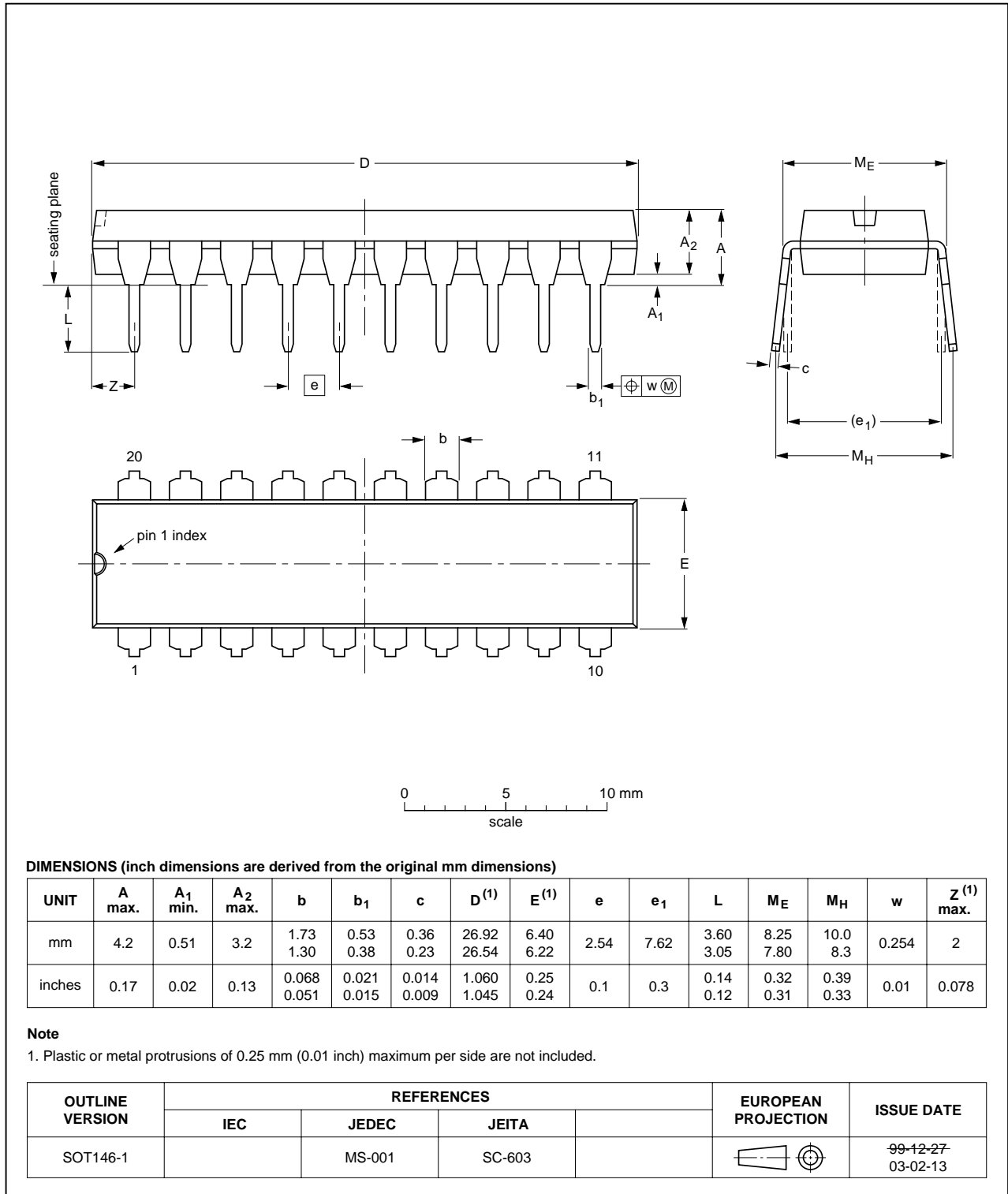

Fig 14. Package outline SOT146-1 (DIP20)

TSSOP20: plastic thin shrink small outline package; 20 leads; body width 4.4 mm

SOT360-1

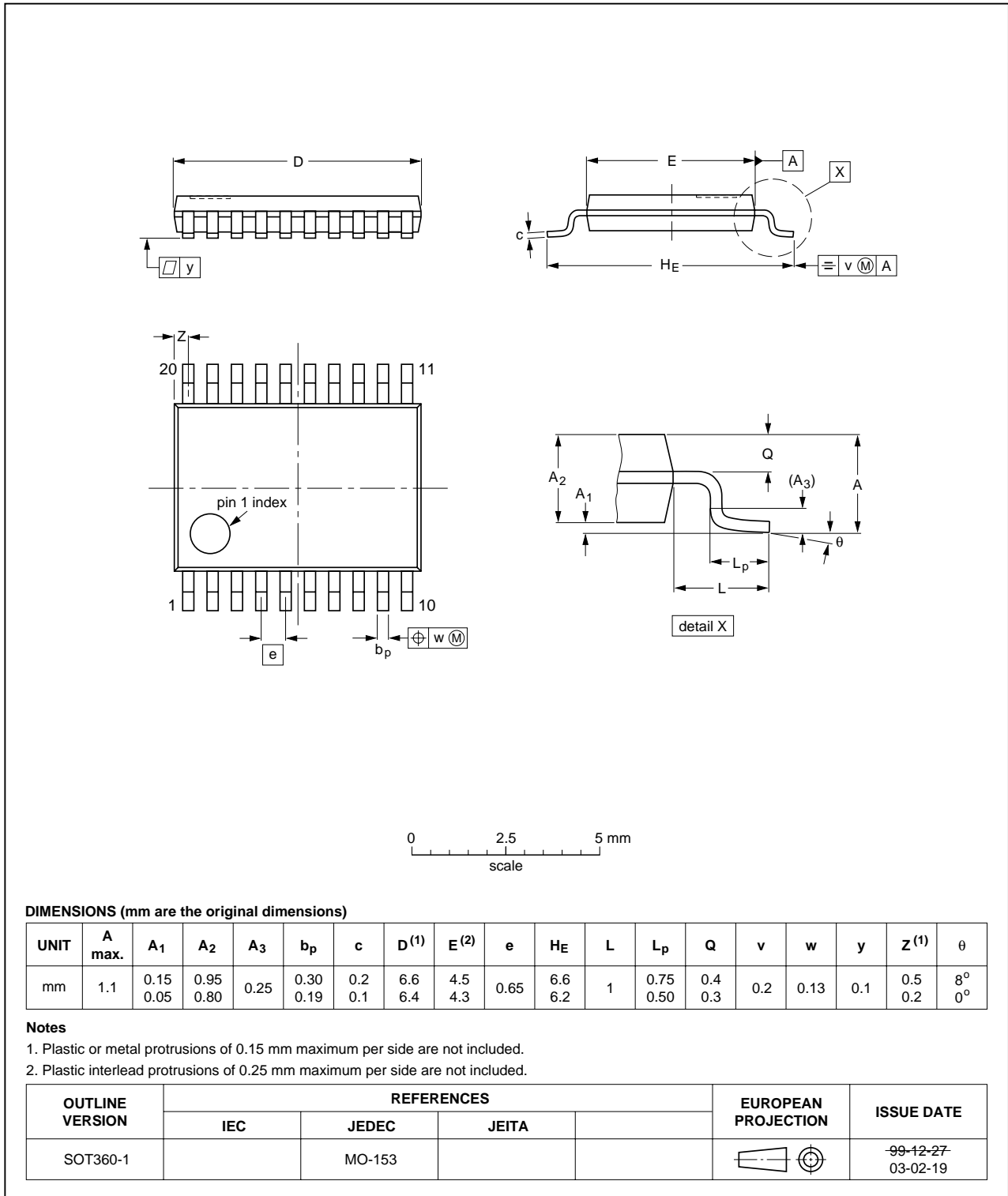

Fig 15. Package outline SOT360-1 (TSSOP20)

13. Revision history

Table 10. Revision history

Document ID	Release date	Data sheet status	Change notice	Supersedes
74HC_HCT299_3	20080728	Product data sheet	-	74HC_HCT299_CNV_2
Modifications:		<ul style="list-style-type: none">• The format of this data sheet has been redesigned to comply with the new identity guidelines of NXP Semiconductors.• Legal texts have been adapted to the new company name where appropriate.• Section 3: Ordering information added• Section 12: Package outline drawings added• Section 9 "Static characteristics": Family data added• Section 11 "Waveforms": Test circuit added		
74HC_HCT299_CNV_2	19970828	Product specification	-	-

14. Legal information

14.1 Data sheet status

Document status ^{[1][2]}	Product status ^[3]	Definition
Objective [short] data sheet	Development	This document contains data from the objective specification for product development.
Preliminary [short] data sheet	Qualification	This document contains data from the preliminary specification.
Product [short] data sheet	Production	This document contains the product specification.

[1] Please consult the most recently issued document before initiating or completing a design.

[2] The term 'short data sheet' is explained in section "Definitions".

[3] The product status of device(s) described in this document may have changed since this document was published and may differ in case of multiple devices. The latest product status information is available on the Internet at URL <http://www.nxp.com>.

14.2 Definitions

Draft — The document is a draft version only. The content is still under internal review and subject to formal approval, which may result in modifications or additions. NXP Semiconductors does not give any representations or warranties as to the accuracy or completeness of information included herein and shall have no liability for the consequences of use of such information.

Short data sheet — A short data sheet is an extract from a full data sheet with the same product type number(s) and title. A short data sheet is intended for quick reference only and should not be relied upon to contain detailed and full information. For detailed and full information see the relevant full data sheet, which is available on request via the local NXP Semiconductors sales office. In case of any inconsistency or conflict with the short data sheet, the full data sheet shall prevail.

14.3 Disclaimers

General — Information in this document is believed to be accurate and reliable. However, NXP Semiconductors does not give any representations or warranties, expressed or implied, as to the accuracy or completeness of such information and shall have no liability for the consequences of use of such information.

Right to make changes — NXP Semiconductors reserves the right to make changes to information published in this document, including without limitation specifications and product descriptions, at any time and without notice. This document supersedes and replaces all information supplied prior to the publication hereof.

Suitability for use — NXP Semiconductors products are not designed, authorized or warranted to be suitable for use in medical, military, aircraft, space or life support equipment, nor in applications where failure or

malfunction of an NXP Semiconductors product can reasonably be expected to result in personal injury, death or severe property or environmental damage. NXP Semiconductors accepts no liability for inclusion and/or use of NXP Semiconductors products in such equipment or applications and therefore such inclusion and/or use is at the customer's own risk.

Applications — Applications that are described herein for any of these products are for illustrative purposes only. NXP Semiconductors makes no representation or warranty that such applications will be suitable for the specified use without further testing or modification.

Limiting values — Stress above one or more limiting values (as defined in the Absolute Maximum Ratings System of IEC 60134) may cause permanent damage to the device. Limiting values are stress ratings only and operation of the device at these or any other conditions above those given in the Characteristics sections of this document is not implied. Exposure to limiting values for extended periods may affect device reliability.

Terms and conditions of sale — NXP Semiconductors products are sold subject to the general terms and conditions of commercial sale, as published at <http://www.nxp.com/profile/terms>, including those pertaining to warranty, intellectual property rights infringement and limitation of liability, unless explicitly otherwise agreed to in writing by NXP Semiconductors. In case of any inconsistency or conflict between information in this document and such terms and conditions, the latter will prevail.

No offer to sell or license — Nothing in this document may be interpreted or construed as an offer to sell products that is open for acceptance or the grant, conveyance or implication of any license under any copyrights, patents or other industrial or intellectual property rights.

14.4 Trademarks

Notice: All referenced brands, product names, service names and trademarks are the property of their respective owners.

15. Contact information

For more information, please visit: <http://www.nxp.com>

For sales office addresses, please send an email to: salesaddresses@nxp.com

16. Contents

1	General description	1
2	Features	1
3	Ordering information	2
4	Functional diagram	2
5	Pinning information	5
5.1	Pinning	5
5.2	Pin description	5
6	Functional description	6
7	Limiting values	6
8	Recommended operating conditions	7
9	Static characteristics	7
10	Dynamic characteristics	10
11	Waveforms	14
12	Package outline	18
13	Revision history	22
14	Legal information	23
14.1	Data sheet status	23
14.2	Definitions	23
14.3	Disclaimers	23
14.4	Trademarks	23
15	Contact information	23
16	Contents	24



Please be aware that important notices concerning this document and the product(s) described herein, have been included in section 'Legal information'.

© NXP B.V. 2008.

All rights reserved.

For more information, please visit: <http://www.nxp.com>

For sales office addresses, please send an email to: salesaddresses@nxp.com

Date of release: 28 July 2008

Document identifier: 74HC_HCT299_3



Looking for pricing, stock, or lifecycle information?

Click below to explore more details on WIN SOURCE:

 [View 74HCT299N,652 on WIN SOURCE](#)

 [NXP / Nexperia Information](#)

Optimize Your Supply Chain with WIN SOURCE Solutions

-  Global Sourcing Solution
-  Obsolete Management
-  Cost Control Management
-  Shortage Management
-  Alternative Solution
-  Excess Inventory Management